



US00D725261S

(12) **United States Design Patent**  
**Barrett et al.**

(10) **Patent No.:** **US D725,261 S**

(45) **Date of Patent:** **\*\* Mar. 24, 2015**

(54) **BLOOD FLOW CHAMBER**

(75) Inventors: **Louis L. Barrett**, West Point, UT (US);  
**Perry N. Law**, Centerville, UT (US)

(73) Assignee: **Fresenius Medical Care Holdings, Inc.**,  
Waltham, MA (US)

(\*\*) Term: **14 Years**

(21) Appl. No.: **29/414,163**

(22) Filed: **Feb. 24, 2012**

(51) **LOC (10) Cl.** ..... **24-02**

(52) **U.S. Cl.**  
USPC ..... **D24/129**

(58) **Field of Classification Search**  
USPC ..... 600/309, 316, 322, 365, 368; D24/169,  
D24/186, 129, 223; D10/81, 96; 356/39  
See application file for complete search history.

(56) **References Cited**

**U.S. PATENT DOCUMENTS**

2,357,238 A	8/1944	Trimble	
D206,714 S	1/1967	Badkar	
D212,218 S	9/1968	Norton	
3,580,683 A	5/1971	Schulkind	
3,728,032 A	4/1973	Noll	
3,740,156 A	6/1973	Heigl et al.	
4,243,883 A	1/1981	Schwarzmann	
D270,281 S	8/1983	Andersen et al.	
4,444,498 A	4/1984	Heinemann	
4,784,768 A	11/1988	Mathieu	
4,936,993 A *	6/1990	Nomura	210/446

(Continued)

**FOREIGN PATENT DOCUMENTS**

EP	0 274 178 A1	7/1988
EP	0 467 805 A1	1/1992

(Continued)

**OTHER PUBLICATIONS**

Blood Chamber 2001—submitted by applicant on Aug. 13, 2014.\*  
(Continued)

*Primary Examiner* — Deanna L Pratt

*Assistant Examiner* — Ieisha Price

(74) *Attorney, Agent, or Firm* — Leydig, Voit & Mayer, Ltd.

(57) **CLAIM**

The ornamental design for a blood flow chamber, as shown and described.

**DESCRIPTION**

FIG. 1 is a perspective view of a first embodiment of a blood flow chamber showing our new design;  
 FIG. 2 is a top elevation view of the blood flow chamber of FIG. 1;  
 FIG. 3 is a bottom elevation view of the blood flow chamber of FIG. 1;  
 FIG. 4 is a side elevation view of the blood flow chamber of FIG. 1;  
 FIG. 5 is one end elevation view of the blood flow chamber of FIG. 1;  
 FIG. 6 is another end elevation view of the blood flow chamber of FIG. 1;  
 FIG. 7 is a perspective view of a second embodiment of a blood flow chamber showing our new design;  
 FIG. 8 is a top elevation view of the blood flow chamber of FIG. 7;  
 FIG. 9 is a bottom elevation view of the blood flow chamber of FIG. 7;  
 FIG. 10 is a side elevation view of the blood flow chamber of FIG. 7;  
 FIG. 11 is one end elevation view of the blood flow chamber of FIG. 7; and,  
 FIG. 12 is another end elevation view of the blood flow chamber of FIG. 7.

The broken lines in the drawings illustrate portions of the blood flow chamber which form no part of the claimed design.

**1 Claim, 6 Drawing Sheets**

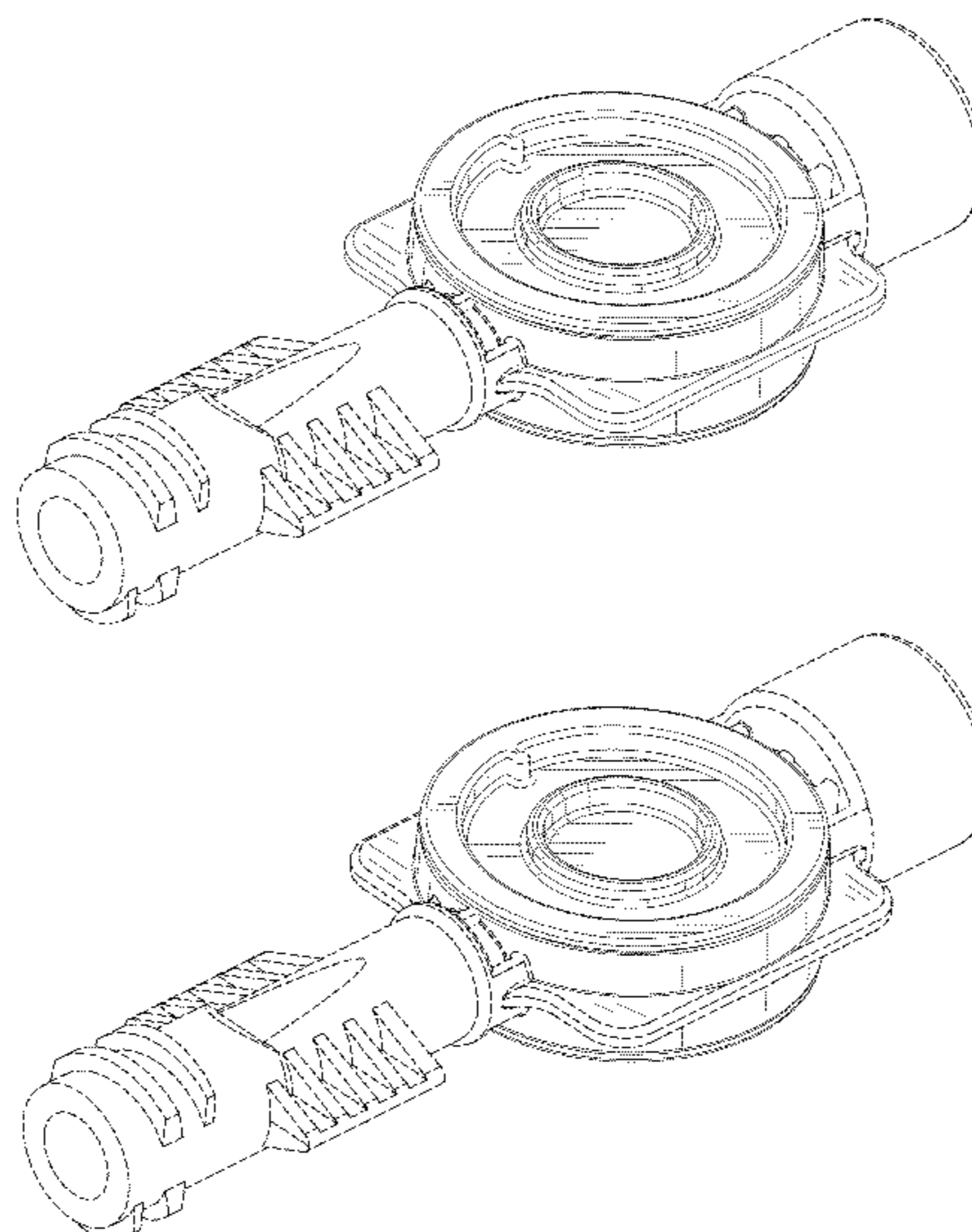

(56)

References Cited

U.S. PATENT DOCUMENTS

5,073,171 A 12/1991 Eaton  
 5,171,456 A 12/1992 Hwang et al.  
 D335,096 S 4/1993 Marsh  
 5,222,948 A 6/1993 Austin et al.  
 5,231,464 A 7/1993 Ichimura et al.  
 5,247,434 A 9/1993 Peterson et al.  
 5,312,535 A 5/1994 Waska et al.  
 5,351,686 A 10/1994 Steuer et al.  
 5,366,630 A 11/1994 Chevallet  
 5,372,136 A 12/1994 Steuer et al.  
 5,456,253 A 10/1995 Steuer et al.  
 5,458,566 A 10/1995 Herrig et al.  
 5,476,764 A 12/1995 Bitensky  
 5,670,050 A 9/1997 Brose et al.  
 5,674,390 A 10/1997 Matthews et al.  
 5,676,644 A 10/1997 Toavs et al.  
 5,729,333 A 3/1998 Osten et al.  
 5,730,712 A 3/1998 Falkvall et al.  
 5,762,805 A 6/1998 Truitt et al.  
 5,769,815 A 6/1998 Utterberg  
 5,792,052 A 8/1998 Isaacson et al.  
 D409,750 S 5/1999 Hacker  
 6,018,673 A 1/2000 Chin et al.  
 6,069,687 A 5/2000 Briggs  
 6,090,061 A 7/2000 Steuer et al.  
 6,284,131 B1 9/2001 Hogard et al.  
 6,284,142 B1 9/2001 Muller  
 6,510,330 B1 1/2003 Enejder  
 6,554,788 B1 4/2003 Hunley et al.  
 6,746,415 B1 6/2004 Steuer et al.  
 7,018,353 B2 3/2006 Hunley et al.  
 D518,573 S 4/2006 French  
 7,247,143 B2 7/2007 Law et al.  
 7,671,974 B2 3/2010 O'Mahony et al.  
 D623,302 S 9/2010 Barrett et al.  
 D625,824 S \* 10/2010 Brackett et al. .... D24/188  
 D630,536 S 1/2011 Pettit  
 D654,999 S \* 2/2012 Barrett et al. .... D24/129  
 8,133,194 B2 3/2012 Szamoadalvi et al.  
 8,287,739 B2 10/2012 Barrett et al.  
 8,328,748 B2 12/2012 Law et al.  
 8,333,724 B2 12/2012 Barrett et al.  
 D684,695 S \* 6/2013 Green et al. .... D24/169  
 D684,697 S \* 6/2013 Green et al. .... D24/169  
 8,517,968 B2 8/2013 Barrett et al.  
 D698,440 S \* 1/2014 Lombardi et al. .... D24/129  
 2001/0016699 A1 8/2001 Burbank et al.  
 2001/0021817 A1 9/2001 Brugger et al.  
 2001/0037079 A1 11/2001 Burbank et al.  
 2001/0041892 A1 11/2001 Burbank et al.  
 2002/0103453 A1 8/2002 Burbank et al.  
 2002/0147423 A1 10/2002 Burbank et al.  
 2003/0009123 A1 1/2003 Brugger et al.  
 2003/0045784 A1 3/2003 Palatnik et al.  
 2003/0070969 A1 4/2003 Muller et al.  
 2003/0097087 A1 5/2003 Gura  
 2003/0143116 A1 7/2003 Zheng et al.  
 2003/0196949 A1 \* 10/2003 Sunohara et al. .... 210/321.71  
 2003/0210390 A1 11/2003 O'Mahoney et al.  
 2003/0212316 A1 11/2003 Leiden et al.  
 2005/0094127 A1 5/2005 O'Mahony et al.  
 2006/0036185 A1 2/2006 Lewicke et al.  
 2006/0144776 A1 \* 7/2006 Mishkin et al. .... 210/321.69  
 2006/0226079 A1 10/2006 Mori et al.  
 2007/0100219 A1 5/2007 Sweutzer et al.  
 2007/0149871 A1 6/2007 Sarussi et al.  
 2007/0179433 A1 8/2007 Jonsson et al.  
 2008/0081970 A1 4/2008 Boyce et al.  
 2008/0129047 A1 \* 6/2008 Blivet et al. .... 285/308  
 2008/0300570 A1 12/2008 Fowles et al.  
 2009/0054751 A1 2/2009 Babashan et al.  
 2010/0004518 A1 1/2010 Vo et al.  
 2010/0110416 A1 5/2010 Barrett et al.  
 2010/0113891 A1 5/2010 Barrett et al.  
 2010/0168531 A1 7/2010 Shaltis et al.

2011/0004082 A1 1/2011 Poeze et al.  
 2011/0022077 A1 \* 1/2011 Green et al. .... 606/203  
 2011/0160679 A1 6/2011 Okiyama et al.  
 2012/0120384 A1 5/2012 Barrett et al.  
 2012/0154789 A1 6/2012 Barrett et al.

FOREIGN PATENT DOCUMENTS

EP 0 990 444 A2 4/2000  
 GB 1 583 023 A 1/1981  
 WO WO 93/06456 A1 4/1993  
 WO WO 93/06774 A1 4/1993  
 WO WO 94/27495 A1 12/1994  
 WO WO 98/37801 A1 9/1998  
 WO WO 00/33053 A1 6/2000  
 WO WO 01/87151 A2 11/2001  
 WO WO 01/93944 A1 12/2001  
 WO WO 02/78783 A2 10/2002

OTHER PUBLICATIONS

CL Photo 2000—submitted by applicant on Aug. 13, 2014.\*  
 Blood Chamber Instruction Sheet 2001.  
 Office action for co-pending Canadian Patent Application No. 2,742,619, dated Aug. 5, 2013.  
 Office action for co-pending Canadian Patent Application No. 2,742,794, including original claims as filed.  
 Official action for co-pending European Patent Application No. 11 755 533.4 dated Apr. 16, 2013.  
 Official action for co-pending European Patent Application No. 11 754 974.1 dated Apr. 16, 2013.  
 Written Opinion for International Patent Application No. PCT/US2011/061273.  
 International Search Report PCT/US2012/026637 (Jun. 6, 2012).  
 Written Opinion of PCT/US2012/026637 (Jun. 6, 2012).  
 Sacker-Berstein, Jonathan D., M.D., et al., "How Should Diuretic-Refractory Volume-Overloaded Heart Failure Patients Be Managed?", *The Journal of Invasive Cardiology*, vol. 15., No. 10 (Oct. 2003), pp. 585-590, retrieved from [http://www.medscape.com/viewarticle/463509\\_print](http://www.medscape.com/viewarticle/463509_print) on Mar. 11, 2013, pp. 1-11.  
 Jaski, Brian E., M.D., "Peripherally Inserted Veno-Venous Ultrafiltration for Rapid Treatment of Volume Overloaded Patients", *Journal of Cardiac Failure*, vol. 9, No. 3 (Jun. 2003) pp. 227-231.  
 Steuer, et al., "Optical Measurement of Hematocrit and Other Biological Constituents in Renal Therapy", *Advances in Renal Replacement Therapy*, vol. 6, No. 3 (Jul. 1999), pp. 217-224.  
 Gardner, "Exponential Smoothing: The State of Art", *Journal of Forecasting*, vol. 4, 1985, (pp. 1-28).  
 Baum, "An Introduction to Modern Econometrics Using Strata", *StataCorp., LP*, 2006, Chapter 9 "Panel-data models", (pp. 219-245).  
 International Search Report for International No. PCT/US2009/057964, dated Jun. 18, 2010.  
 Logman, Dirren H., MHGM, et al., Abstract—"Altitude Correction for Hemoglobin", *European Journal of Clinical Nutrition*, (Believed to be no longer in publication).  
 Barrett, Lee, Peer Review, "Effects of CPD and K2EDTA Preservatives on Blood Sample Hematocrit", *Asaio Abstract Submission Information, 45th Annual Conference*, San Diego, Jun. 3-5, 1999.  
 Cohen, Jennifer H., et al., "Hemoglobin Correction Factors for Estimating the Prevalence of Iron Deficiency Anemia in Pregnant Women Residing at High Altitudes in Bolivia", retrieved from [http://www.scielo.php?script=sci\\_arttext&pid=S1020-49891999001100004](http://www.scielo.php?script=sci_arttext&pid=S1020-49891999001100004) on Jun. 19, 2009 (12 pages).  
 Zhang, S., Ph.D., et al., "Hematocrit Measurement Error Due to Time Dependence of Hematocrit for EDTA-Preserved Blood Samples", *ASN 36 Annual Meeting & Scientific Exposition*, retrieved from <http://www.call4abstracts.com/ams/main/finalpreview>, site visited Jun. 25, 2003.

(56)

**References Cited**

OTHER PUBLICATIONS

Crit-Line Hematocrit Accuracy Hema Metrics, vol. 1, Tech Note No. 11 (Rev D), pp. 1-4, Feb. 24, 2003.  
ScienceStockroom Flow Through Cuvette, 14 pages.

International Search Report of International Application No. PCT/US2011/061273 (Mar. 13, 2012).

Barrett, Lee, "Effects of CPD and K<sub>3</sub> EDTA Preservatives on Blood Sample Hematocrit", *Abstract Submission, ASIAO, 45th Annual Conference*, San Diego (Jun. 1999).

\* cited by examiner

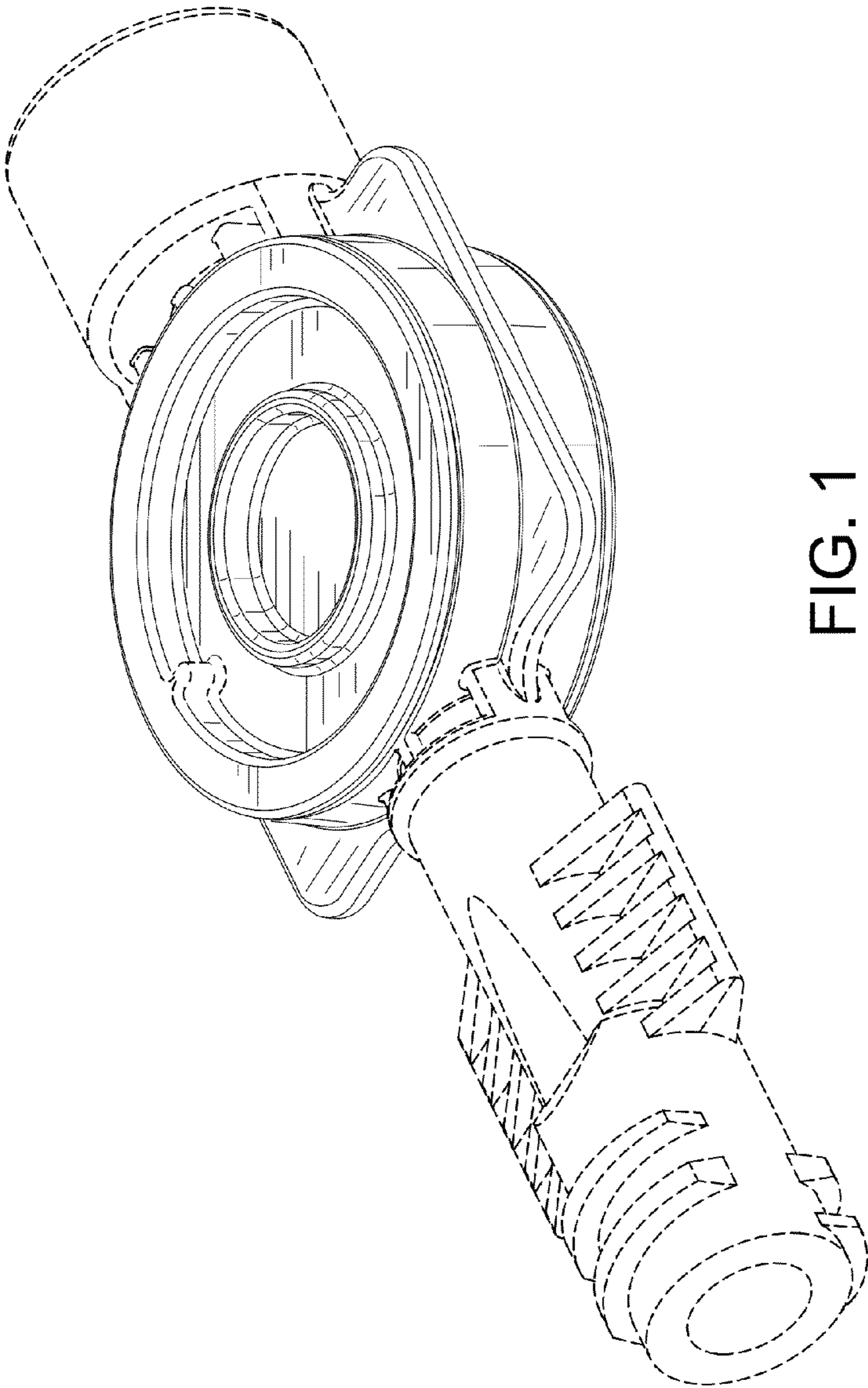

FIG. 1

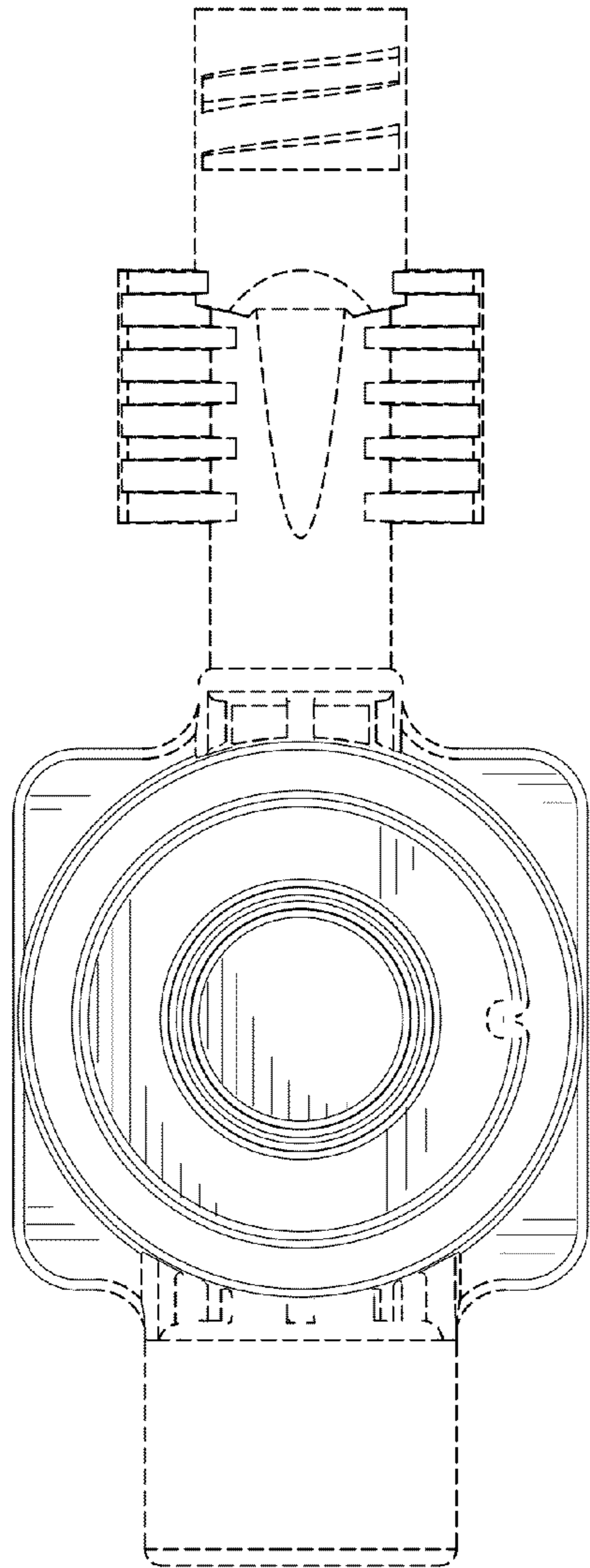

FIG. 2

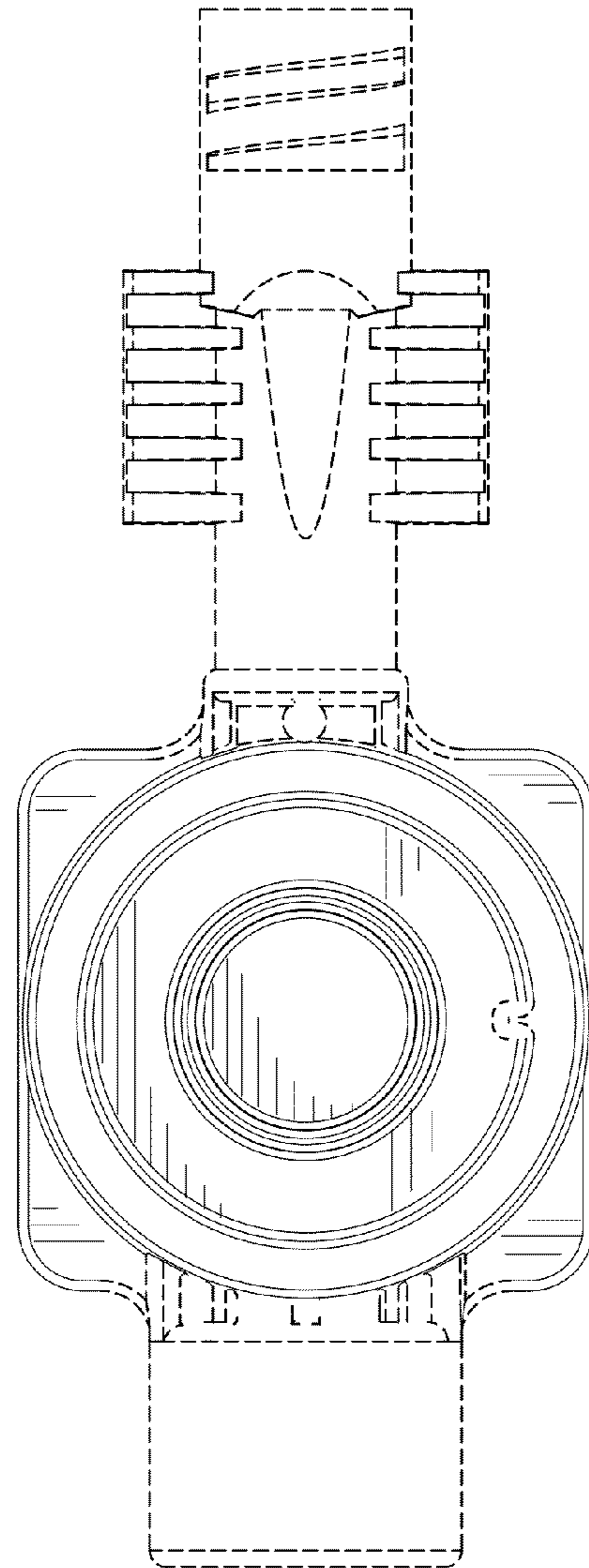

FIG. 3

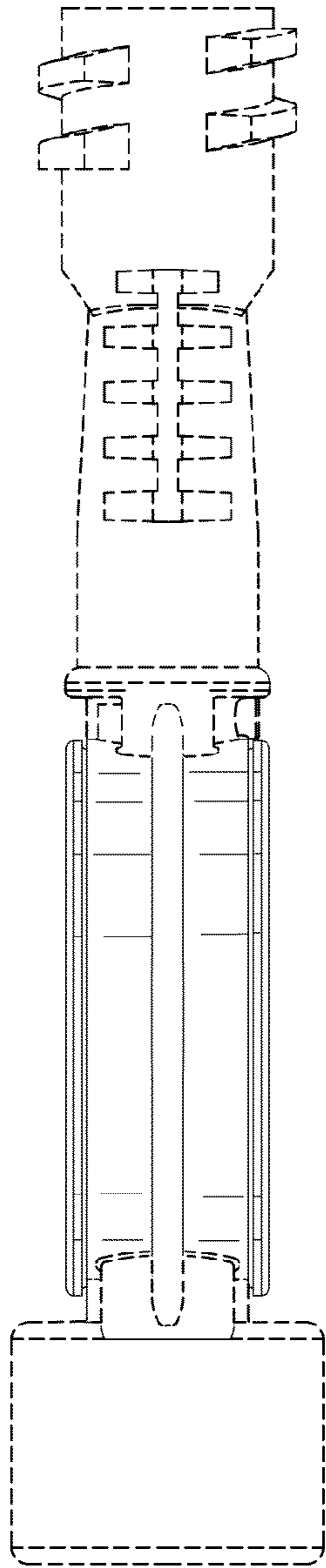

FIG. 4

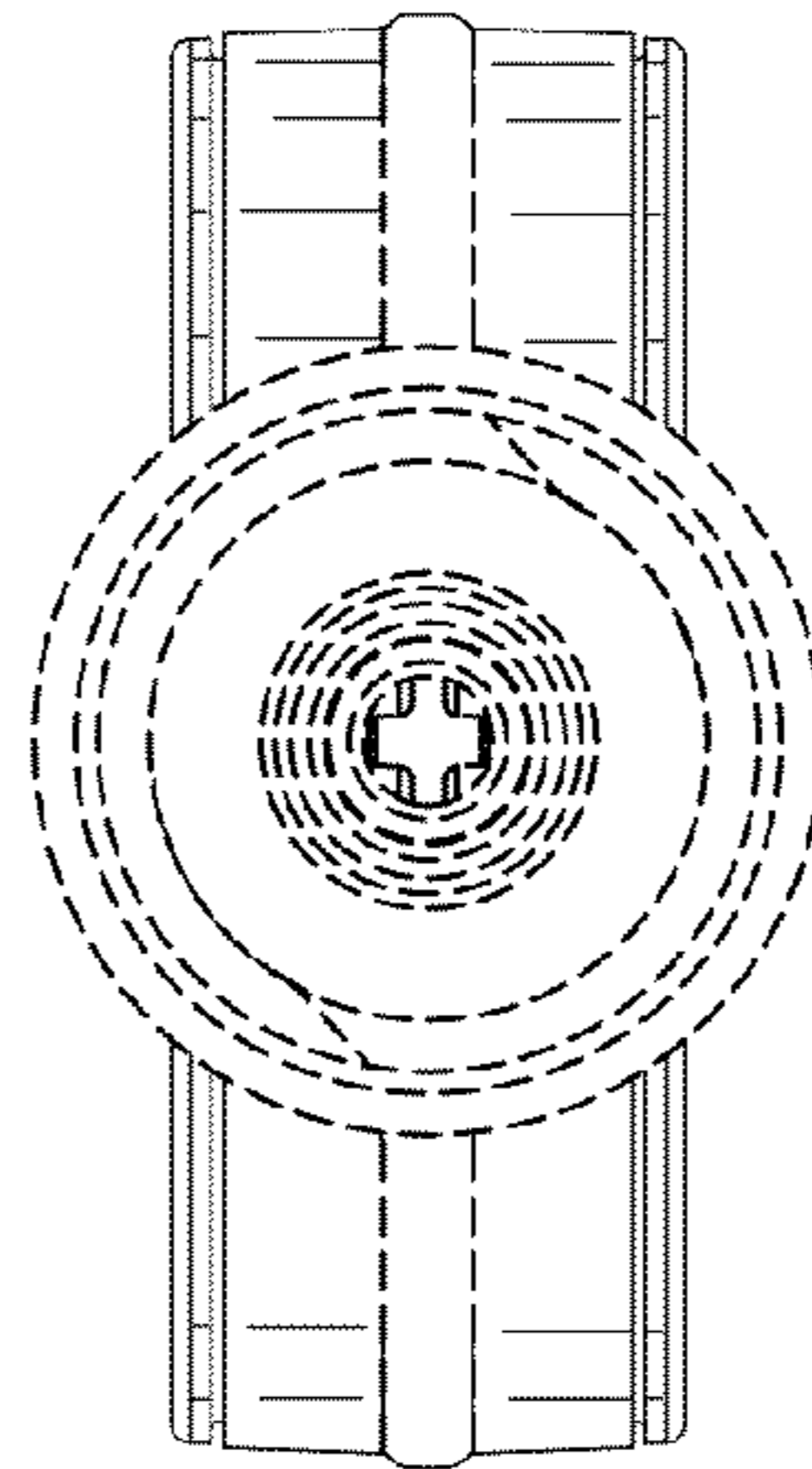

FIG. 5

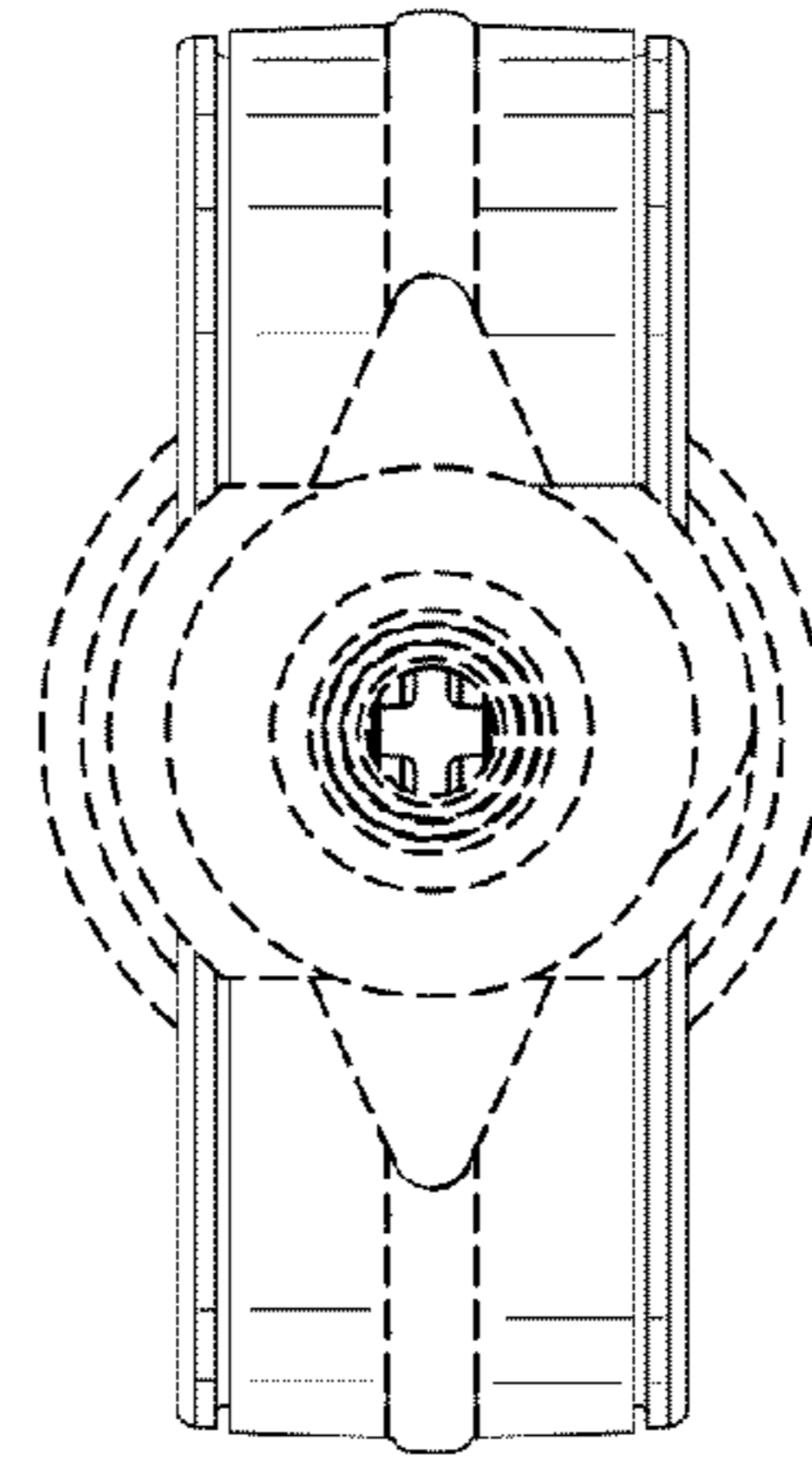

FIG. 6

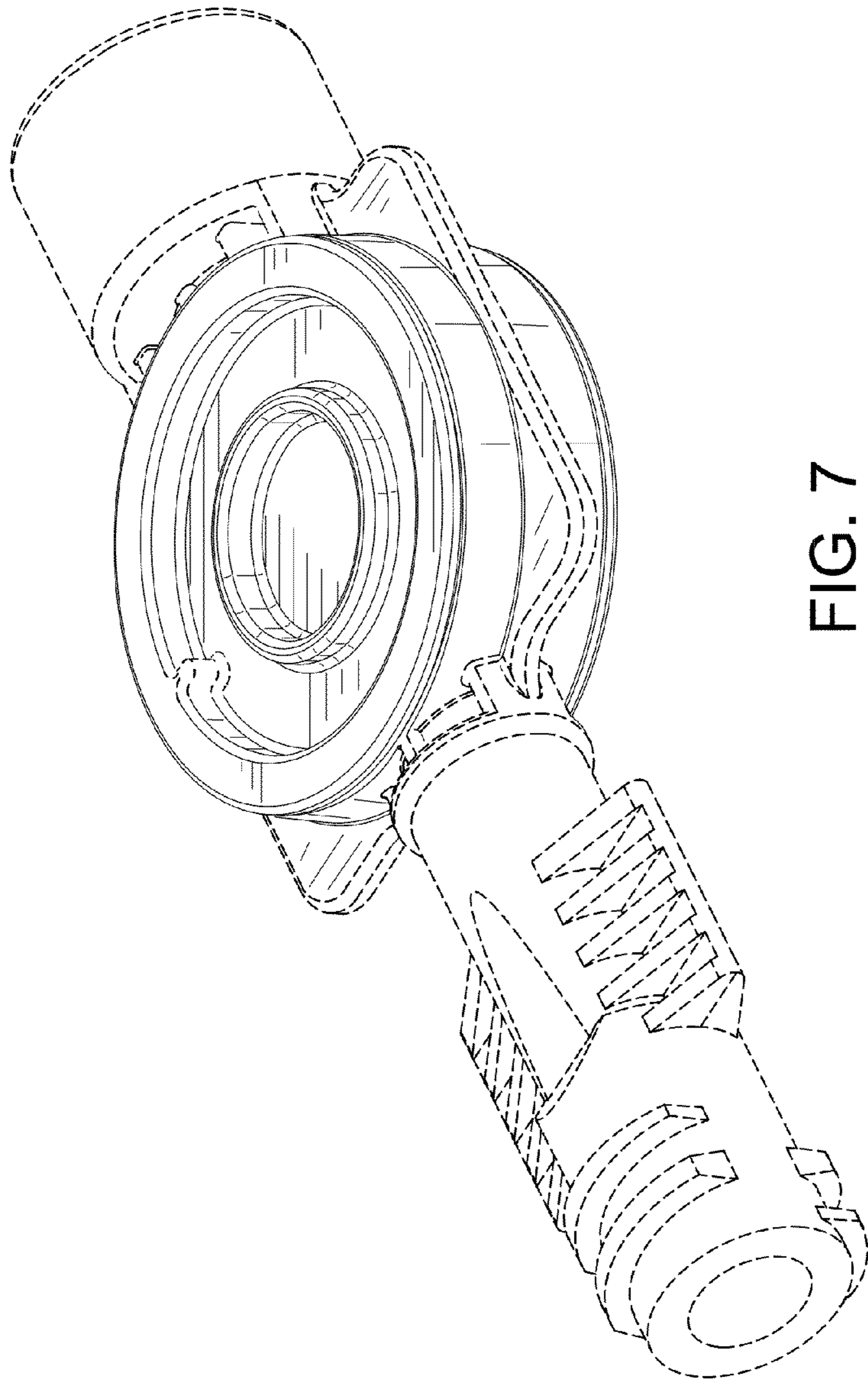

FIG. 7

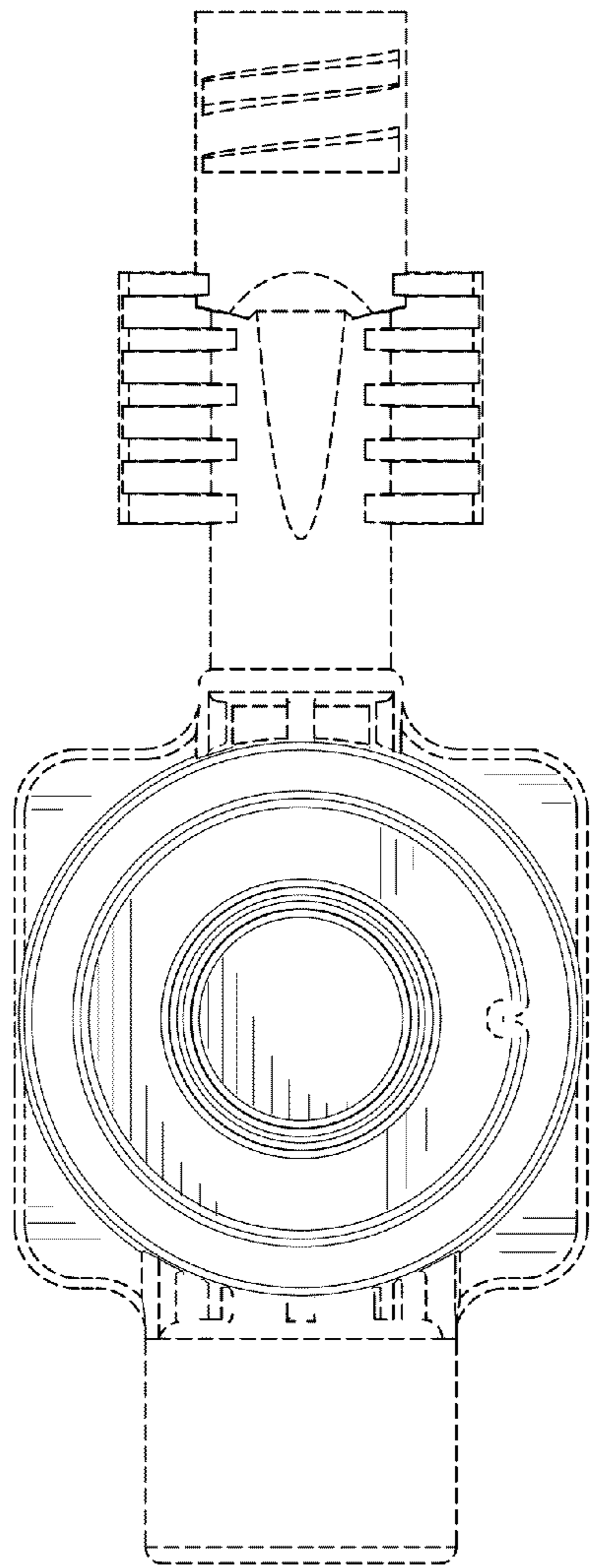

FIG. 8

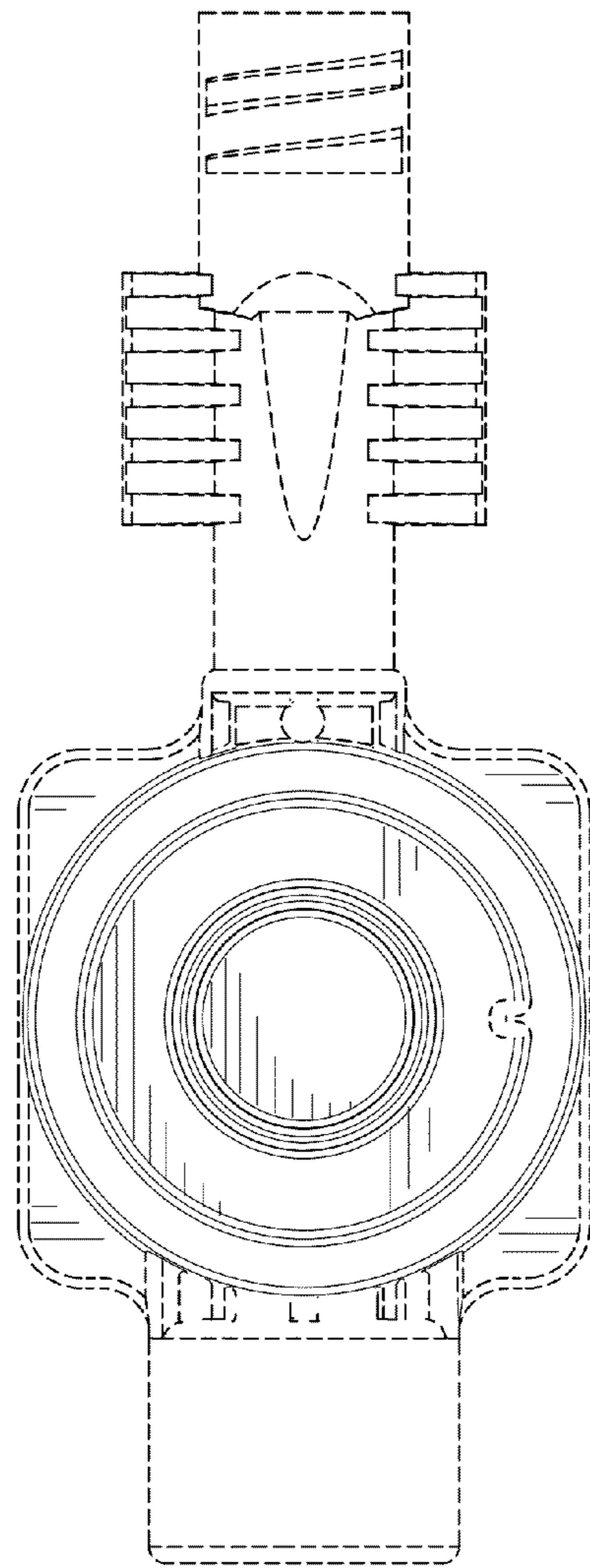

FIG. 9



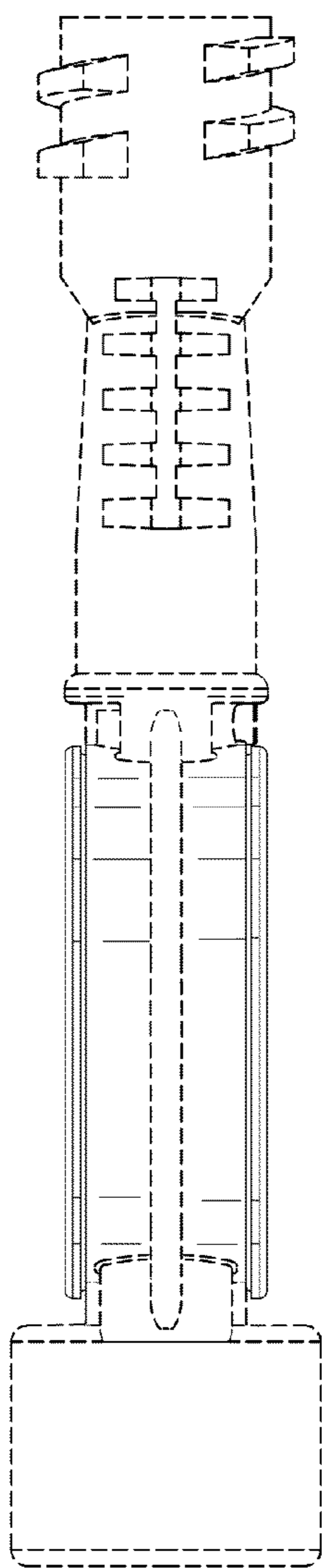

FIG. 10

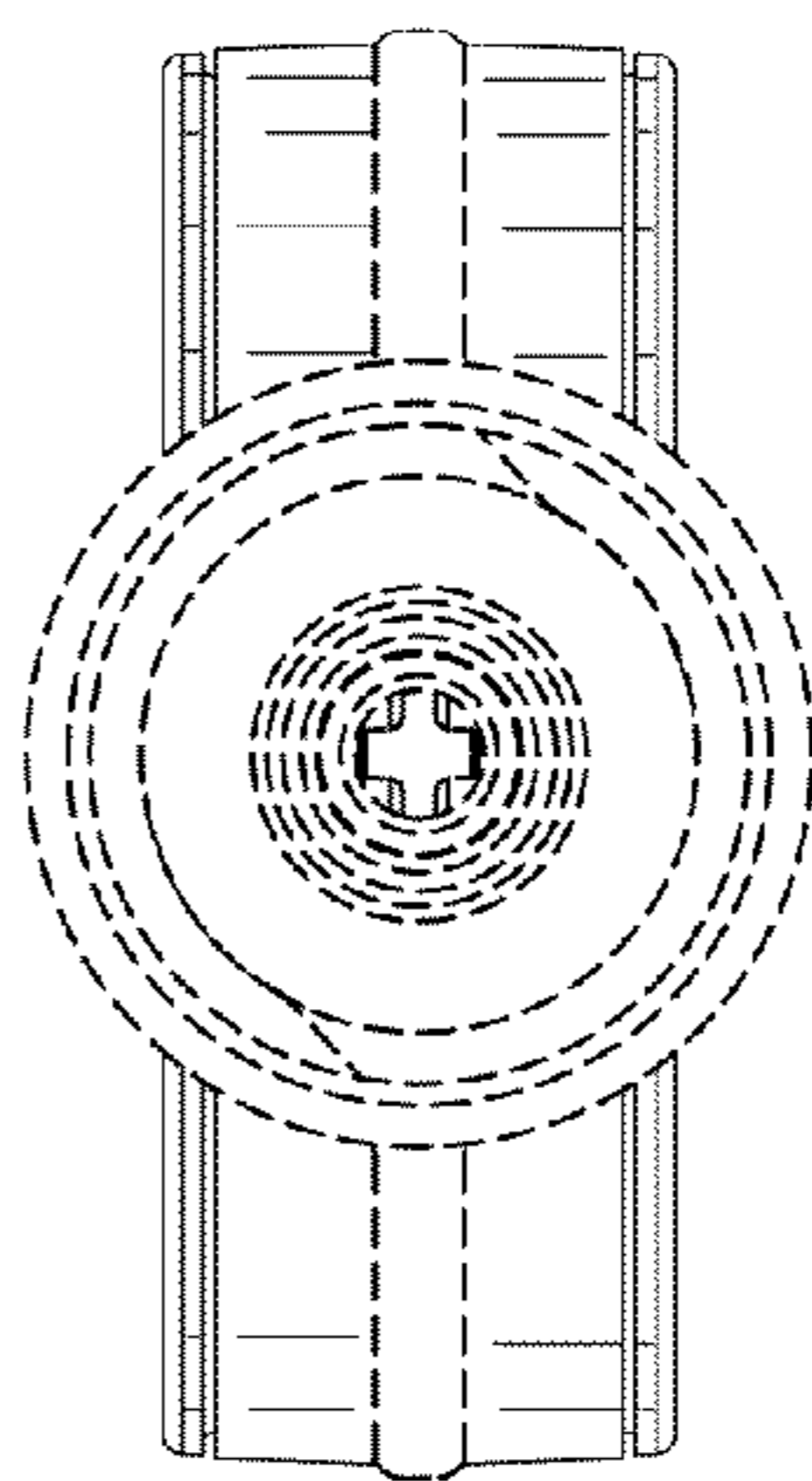

FIG. 11

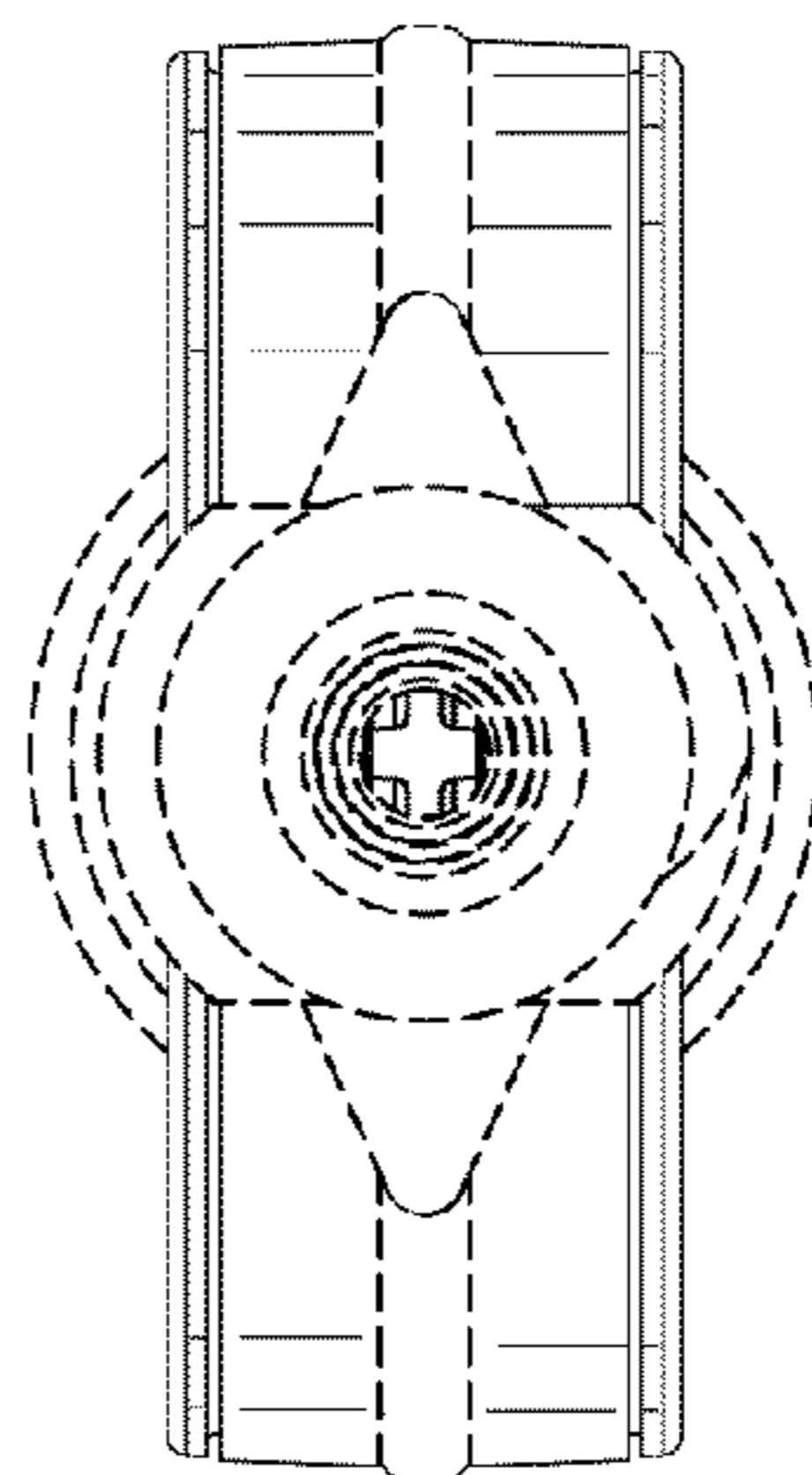

FIG. 12