



US00D725001S

(12) **United States Design Patent**
McMahan et al.

(10) **Patent No.:** **US D725,001 S**
(45) **Date of Patent:** **** Mar. 24, 2015**

- (54) **VEHICLE BODY EXTERIOR**
- (71) Applicant: **GM Global Technology Operations LLC**, Detroit, MI (US)
- (72) Inventors: **Robert B. McMahan**, Bloomfield Hills, MI (US); **Brendon C. Mackay**, Shelby Township, MI (US); **Daniel E. Schmeckpeper**, Clarkston, MI (US)
- (73) Assignee: **GM Global Technology Operations LLC**, Detroit, MI (US)
- (**) Term: **14 Years**
- (21) Appl. No.: **29/478,501**
- (22) Filed: **Jan. 6, 2014**
- (51) **LOC (10) Cl.** **12-08**
- (52) **U.S. Cl.**
USPC **D12/98**
- (58) **Field of Classification Search**
USPC D12/86, 90-92, 88, 98; D21/424, 433, D21/434; 296/181.1, 181.5, 181.3, 183.1
See application file for complete search history.

- D618,595 S 6/2010 Ware et al.
- D657,718 S 4/2012 Zipfel et al.
- D659,052 S 5/2012 Ware et al.
- D659,053 S 5/2012 Ware et al.
- D678,820 S 3/2013 Song et al.
- D700,871 S * 3/2014 O'Donnell et al. D12/98

OTHER PUBLICATIONS

Design U.S. Appl. No. 29/435,117, filed Oct. 19, 2012; First Named Inventor: Kevin M. O'Donnell; Title: Vehicle Body Exterior.
Design U.S. Appl. No. 29/439,307, filed Dec. 10, 2012; First Named Inventor: Brendon C. Mackay; Title: Vehicle Body Exterior.

* cited by examiner

Primary Examiner — Melody Brown

(74) *Attorney, Agent, or Firm* — Lionel D. Anderson; Reising Ethington P.C.

(57) **CLAIM**

The ornamental design for a vehicle body exterior, as shown and described.

DESCRIPTION

FIG. 1 is a front perspective view of the vehicle body exterior; FIG. 2 is a front and left side perspective view thereof; FIG. 3 is a left side elevation view thereof, the right side being substantially a mirror image of that shown without the gas cap over; FIG. 4 is a top plan view thereof; FIG. 5 is a rear and left side perspective view thereof; and, FIG. 6 is a rear perspective view thereof.
The broken lines shown in the drawings depict portions of the vehicle body exterior that form no part of the claimed design.

1 Claim, 6 Drawing Sheets

- (56) **References Cited**
U.S. PATENT DOCUMENTS
D570,742 S 6/2008 Takagi et al.
D600,595 S 9/2009 Nakamura et al.
D601,925 S 10/2009 O'Donnell
D604,203 S 11/2009 O'Donnell

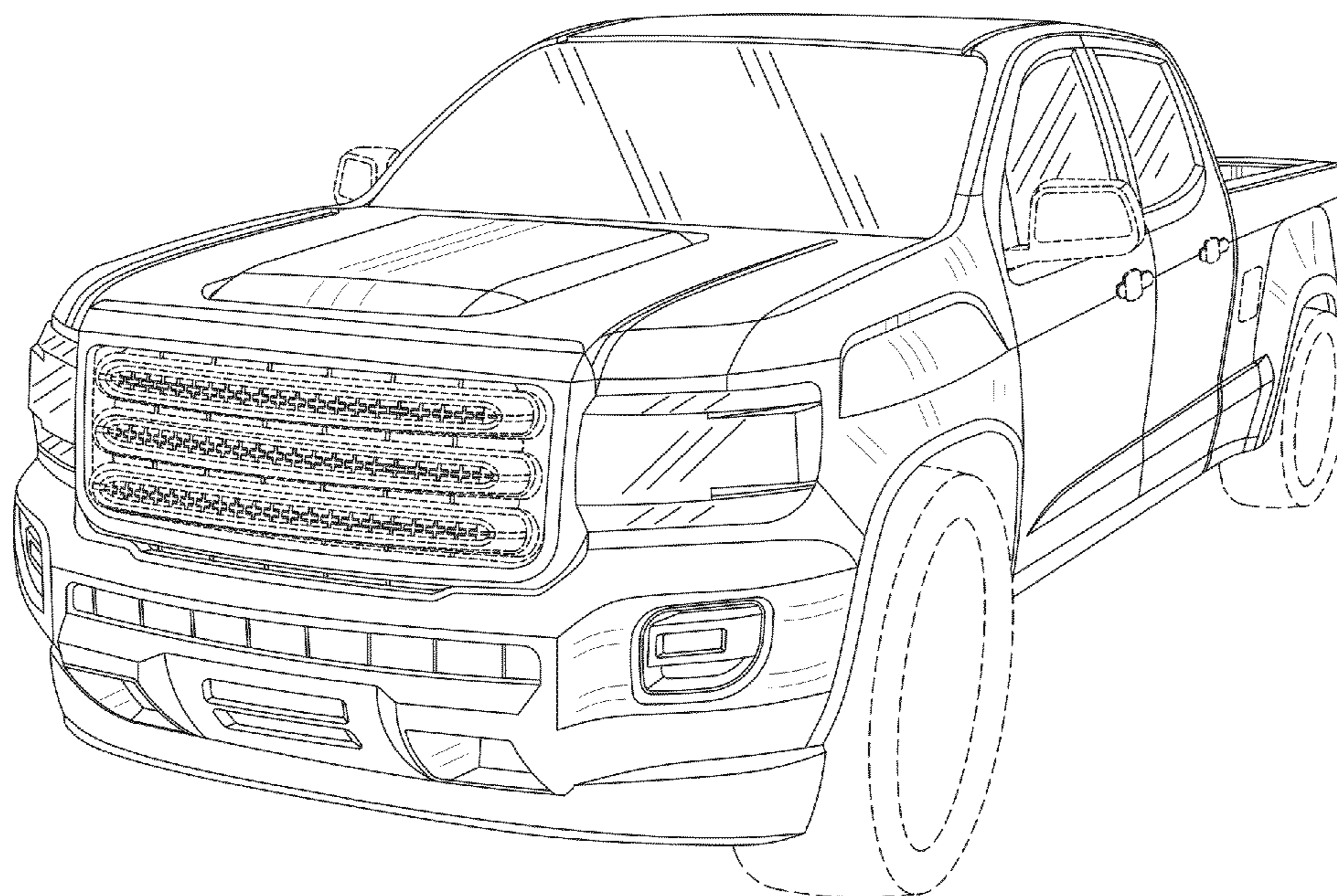

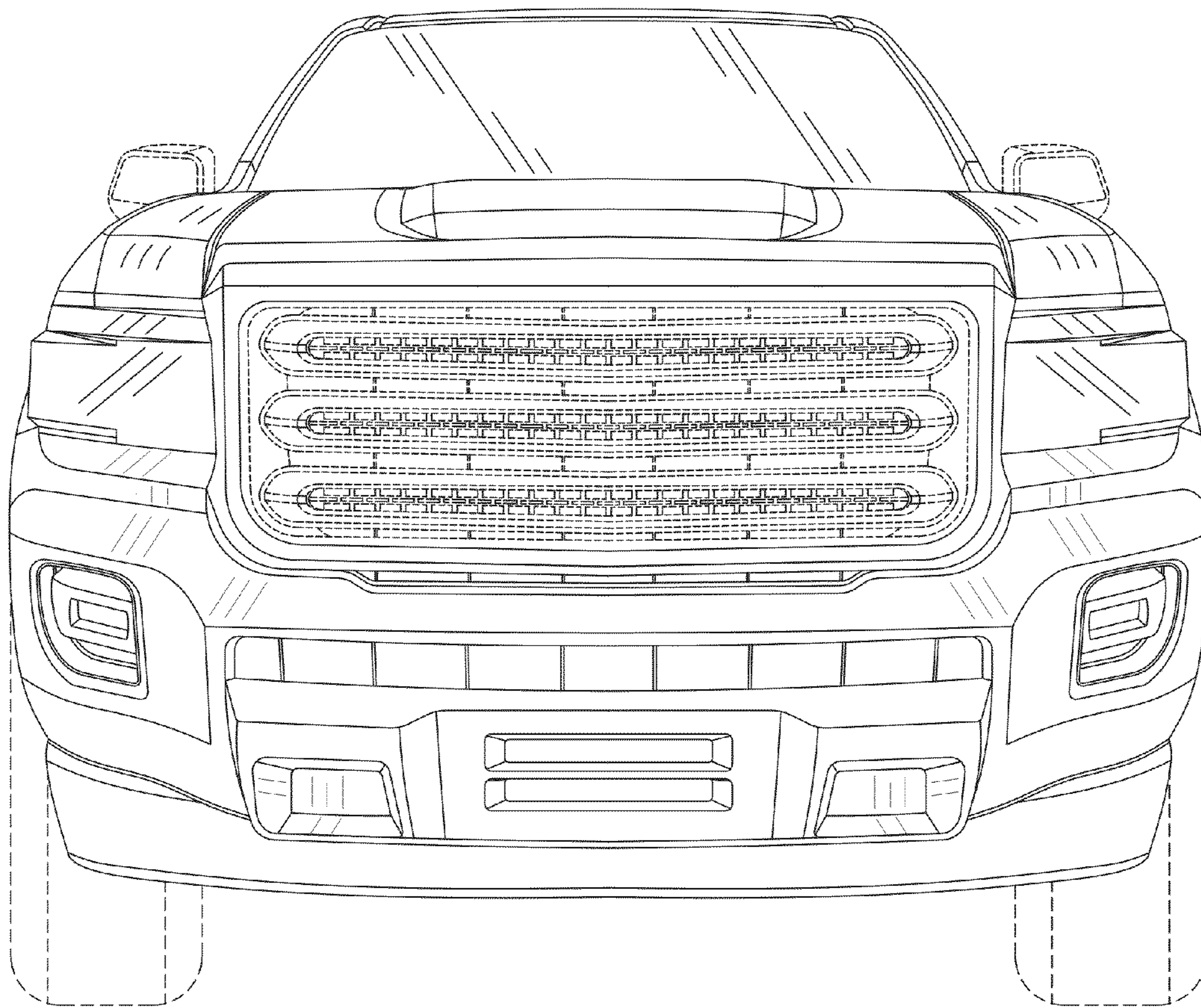

Fig-1

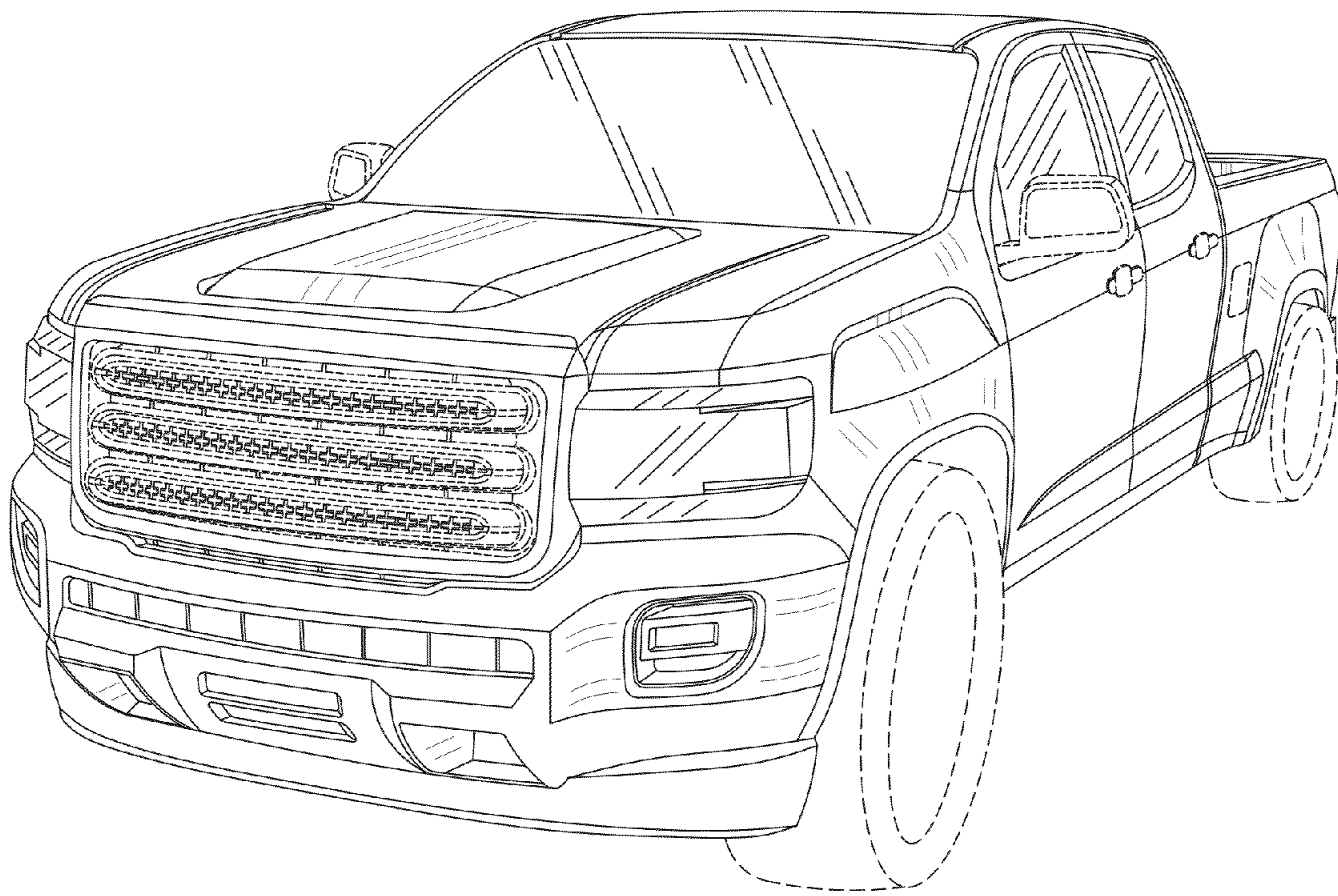

Fig-2

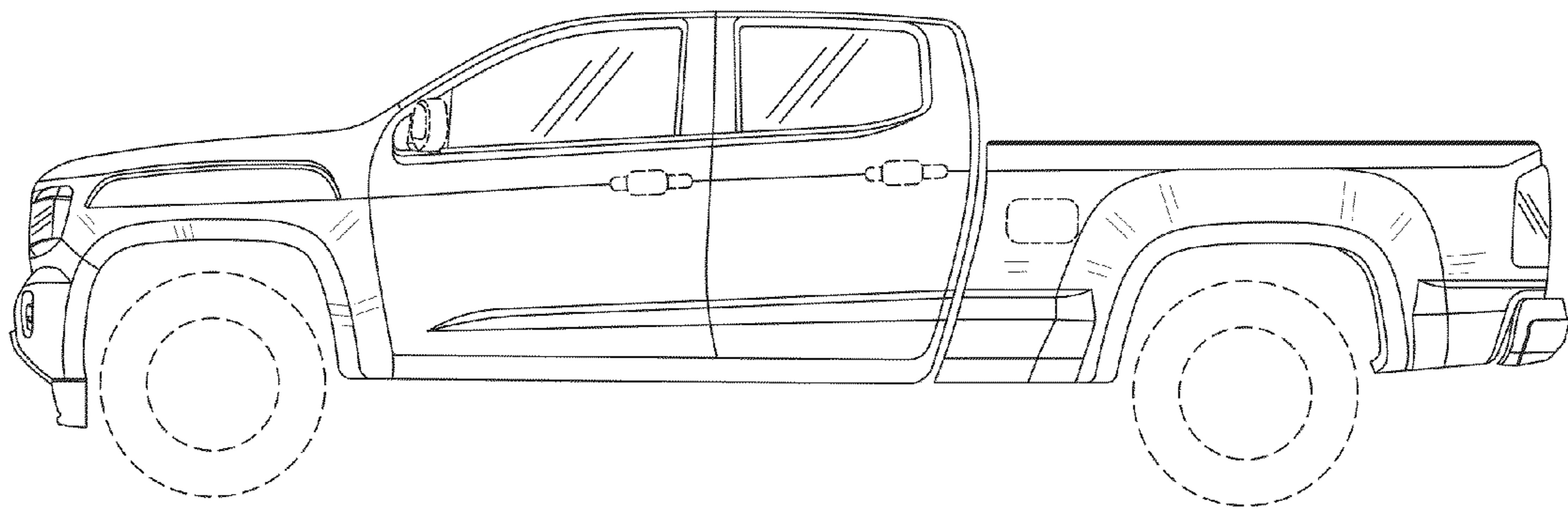

Fig-3

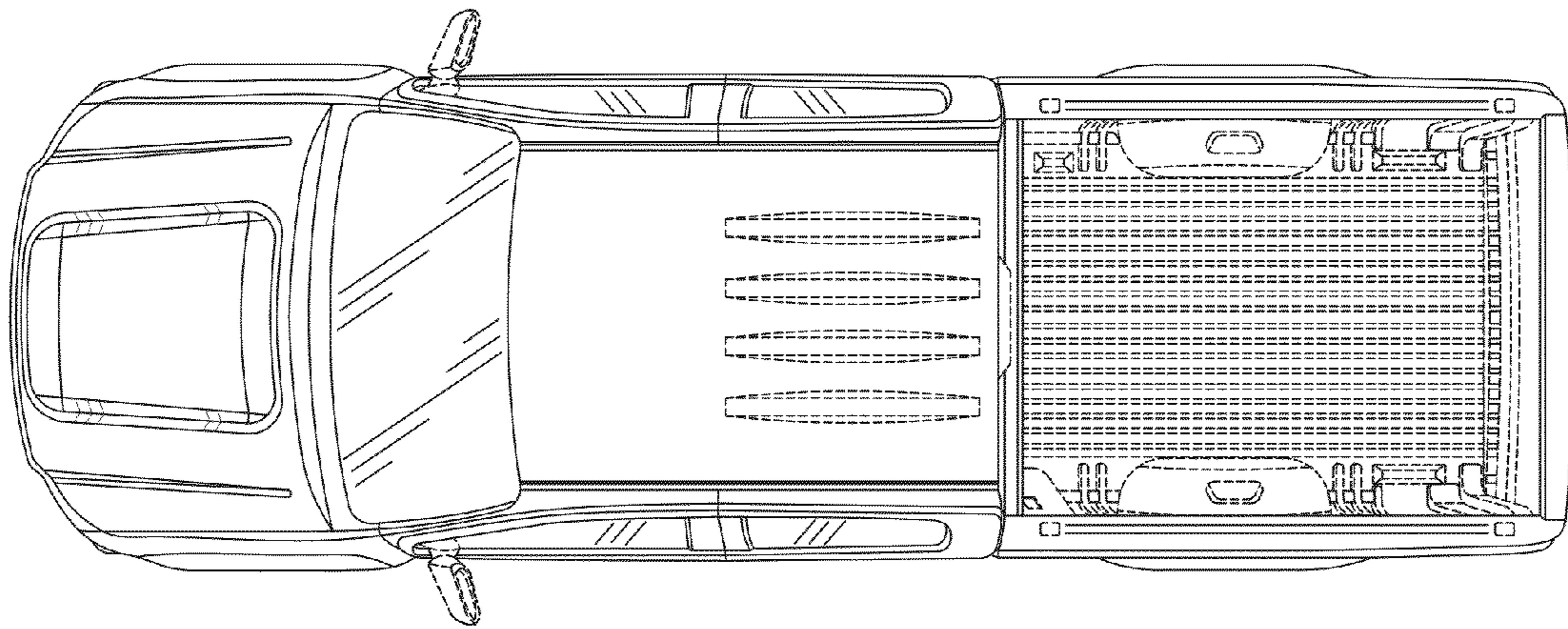

Fig-4

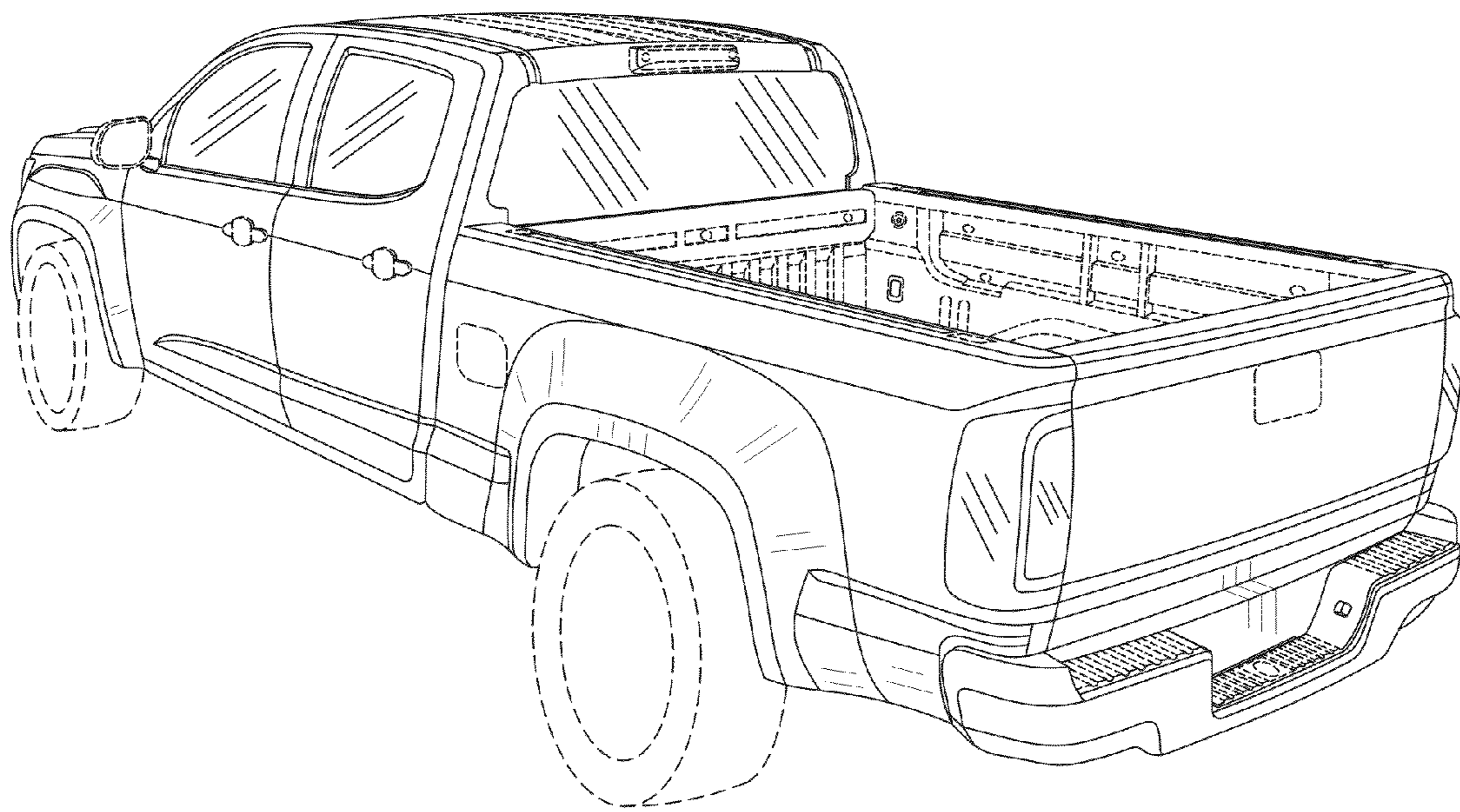

Fig-5

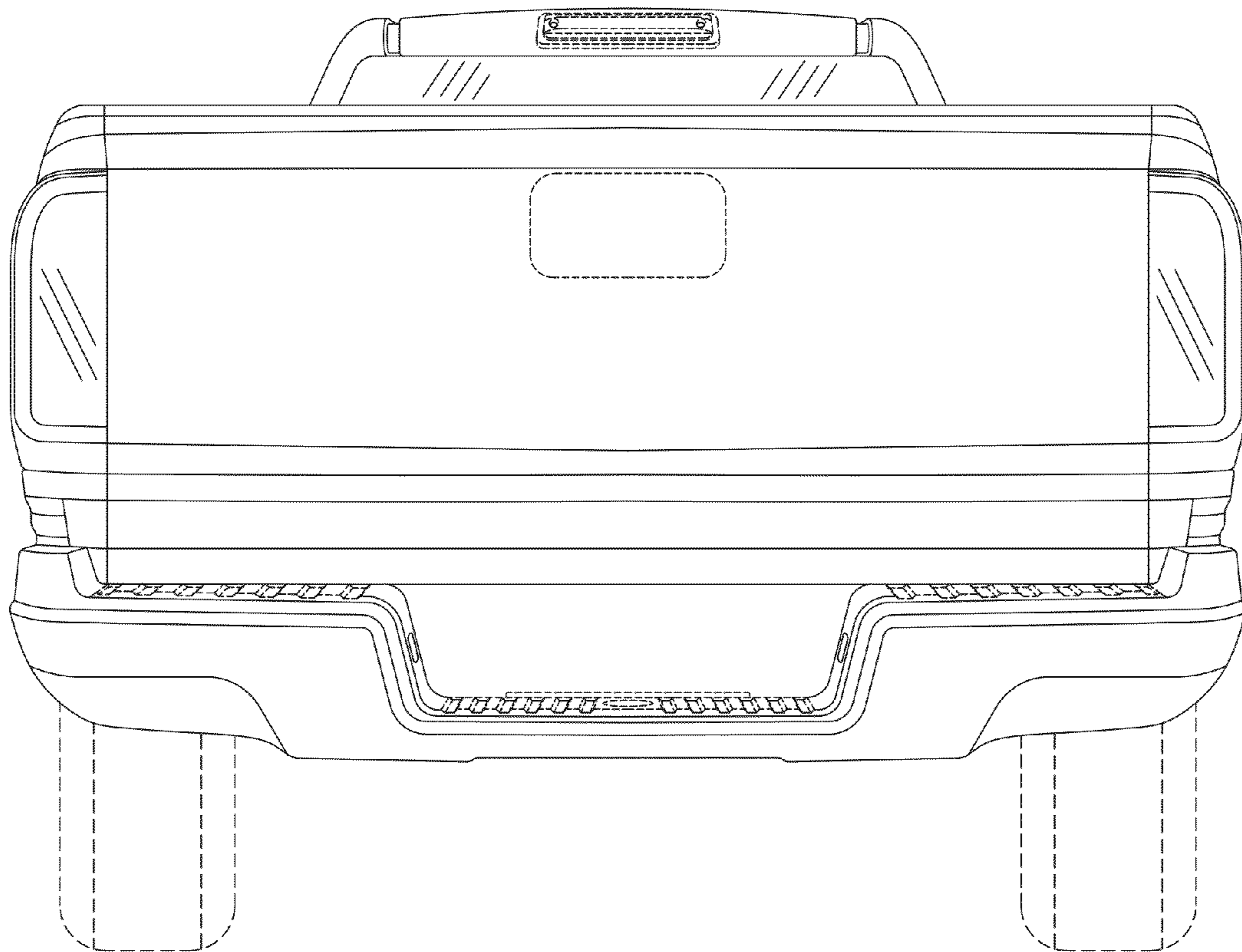

Fig-6