



US00D724791S

(12) **United States Design Patent**
Cram

(10) **Patent No.:** **US D724,791 S**
(45) **Date of Patent:** **** Mar. 17, 2015**

- (54) **PROTECTIVE MOTORSPORTS MASK**
- (71) Applicant: **Bell Sports, Inc.**, Scotts Valley, CA (US)
- (72) Inventor: **Daniel Cram**, Scotts Valley, CA (US)
- (73) Assignee: **Bell Sports, Inc.**, Scotts valley, CA (US)
- (**) Term: **14 Years**
- (21) Appl. No.: **29/454,159**
- (22) Filed: **May 7, 2013**

6,282,726	B1 *	9/2001	Noyerie et al.	2/424
D488,264	S *	4/2004	Masterson	D29/106
6,834,398	B1 *	12/2004	Martinez	2/424
D510,644	S *	10/2005	Batstone	D29/107
7,207,072	B2 *	4/2007	Halsnes et al.	2/424
D547,007	S *	7/2007	Schindler	D29/107
D567,450	S *	4/2008	Renfrew	D29/107
D595,014	S *	6/2009	Tinius	D29/107
7,805,776	B2 *	10/2010	Crossman et al.	2/424
D638,168	S *	5/2011	Lebel et al.	D29/107
D645,210	S *	9/2011	Chilson et al.	D29/106
8,166,575	B2 *	5/2012	Haselmayer	2/422
D666,775	S *	9/2012	Junker et al.	D29/106
D670,447	S *	11/2012	Emrich et al.	D29/106
D682,479	S *	5/2013	Buathier	D29/107

(Continued)

Related U.S. Application Data

- (63) Continuation of application No. 13/834,397, filed on Mar. 15, 2013.
- (51) **LOC (10) CI.** **02-03**
- (52) **U.S. CI.**
USPC **D29/122**
- (58) **Field of Classification Search**
USPC D29/102-110, 122; 2/200.1, 200.2, 2/202, 205, 208, 181, 171, 171.1, 171.3, 2/410-414, 416, 421-425, 427, 5, 6.3, 2/6.5, 6.6, 6.7, 7, 9, 8.2, 457, 2.11, 2.14, 2/209.13, 206; D2/875, 865, 869, 880, D2/175.6; D24/110.3, 110.2; 128/201.23, 128/201.24, 201.29, 202.11; D16/208; 396/429, 433; 348/373; 250/330; 345/8
See application file for complete search history.

Primary Examiner — Ruth McInroy

(74) *Attorney, Agent, or Firm* — Booth Udall Fuller, PLC

(57) **CLAIM**

I claim the ornamental design for a protective motorsports mask, as shown and described.

DESCRIPTION

FIG. 1 is a front perspective view of a protective motorsports mask showing my new design;
 FIG. 2 is a left side view thereof;
 FIG. 3 is a right side view thereof;
 FIG. 4 is a front view thereof;
 FIG. 5 is a rear view thereof;
 FIG. 6 is a bottom view thereof;
 FIG. 7 is a front perspective view of a second embodiment;
 FIG. 8 is a left side view of FIG. 7;
 FIG. 9 is a right side view of FIG. 7;
 FIG. 10 is a front view of FIG. 7;
 FIG. 11 is a rear view of FIG. 7; and,
 FIG. 12 is a bottom view of FIG. 7.
 The broken lines in FIGS. 1-12 are for the purpose of illustrating unclaimed features and form no part of the claimed design.

(56) **References Cited**

U.S. PATENT DOCUMENTS

D253,197	S *	10/1979	Jarvinen	D29/107
4,689,836	A *	9/1987	Vitaloni	2/424
5,003,632	A *	4/1991	Claude	2/422
D324,115	S *	2/1992	Brooks	D29/107
D363,571	S *	10/1995	Klose et al.	D29/106
D382,671	S *	8/1997	Shewchenko	D29/106
D397,519	S *	8/1998	Crupi et al.	D29/107

1 Claim, 12 Drawing Sheets

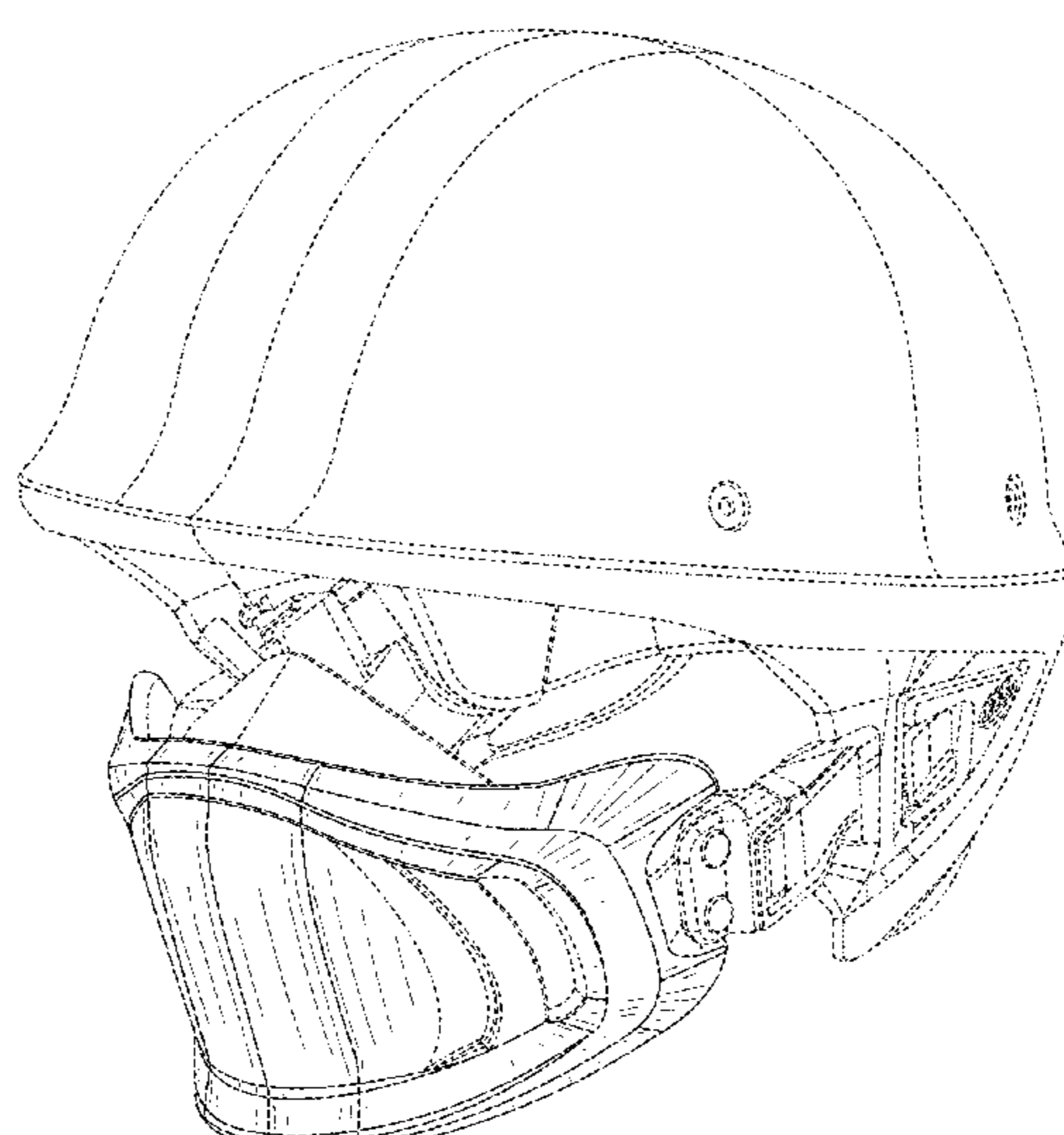
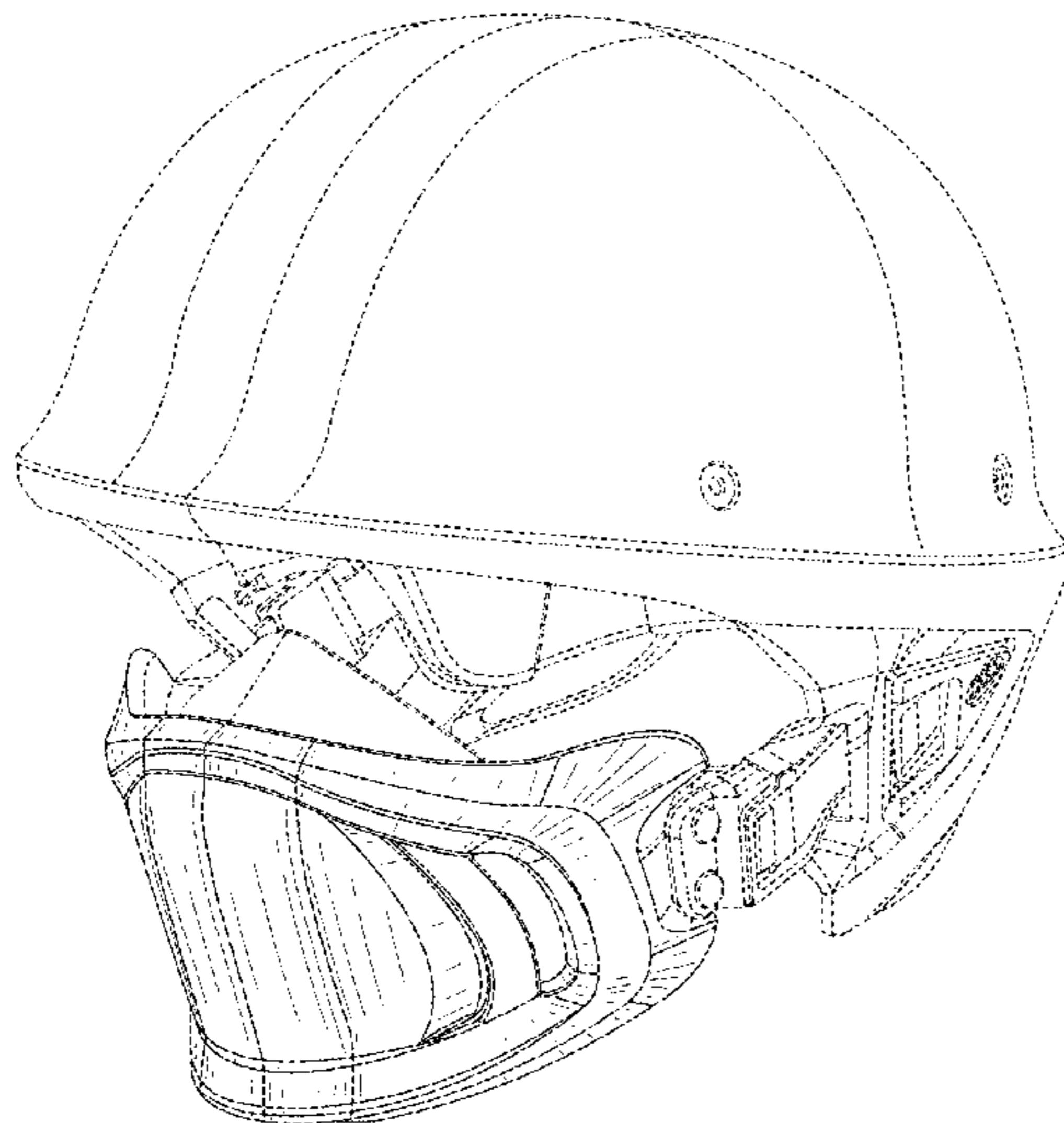

US D724,791 S

Page 2

(56)

References Cited

U.S. PATENT DOCUMENTS

8,484,767	B2 *	7/2013	Nakayama	2/424				
2005/0015861	A1 *	1/2005	Gafforio et al.	2/424				
2005/0183190	A1 *	8/2005	Hussey	2/424				
2008/0127400	A1 *	6/2008	Dupuis	2/424				
2009/0144872	A1 *	6/2009	Lebel et al.	2/6.7				
2011/0277224	A1 *	11/2011	Okuma et al.	2/424				

* cited by examiner

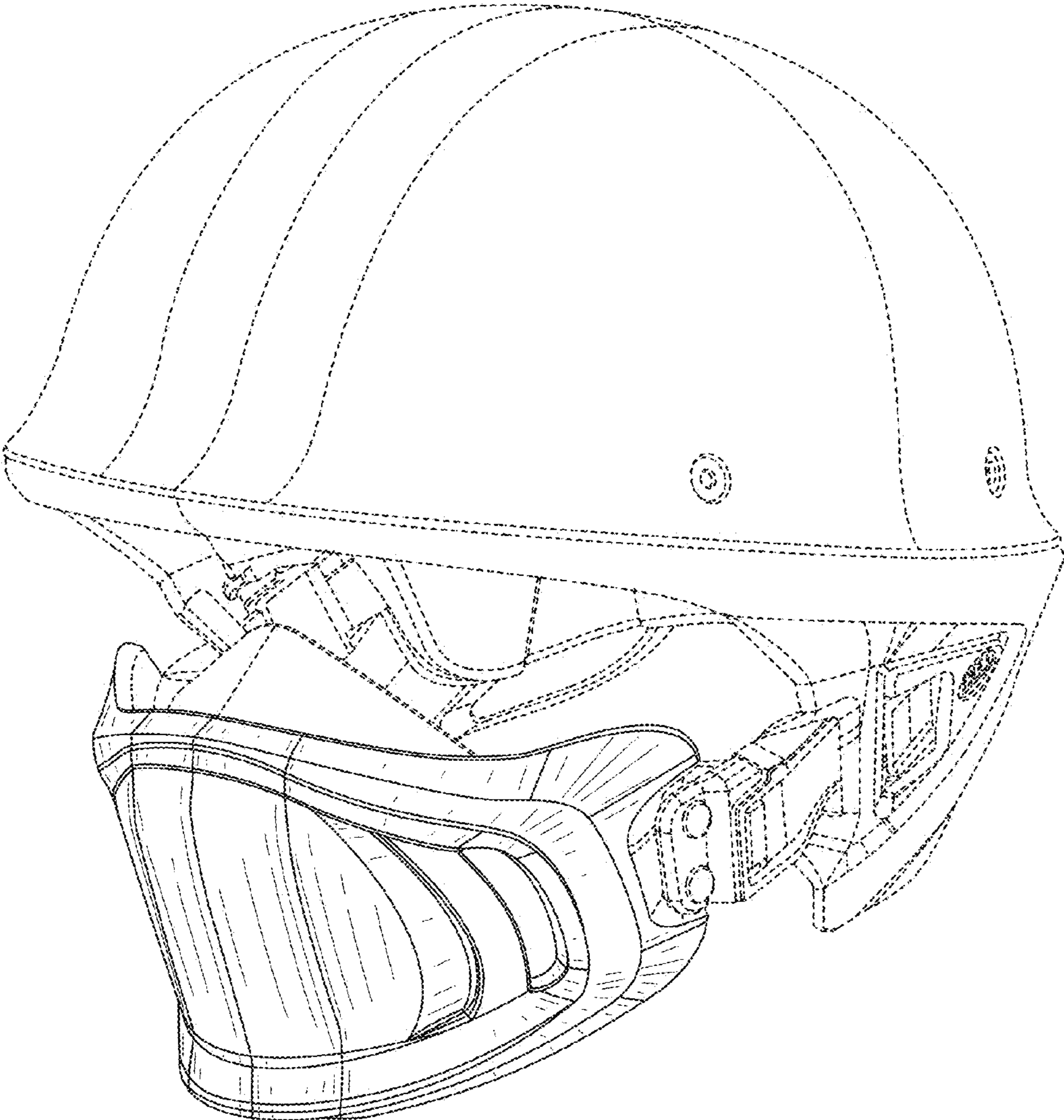

FIG. 1

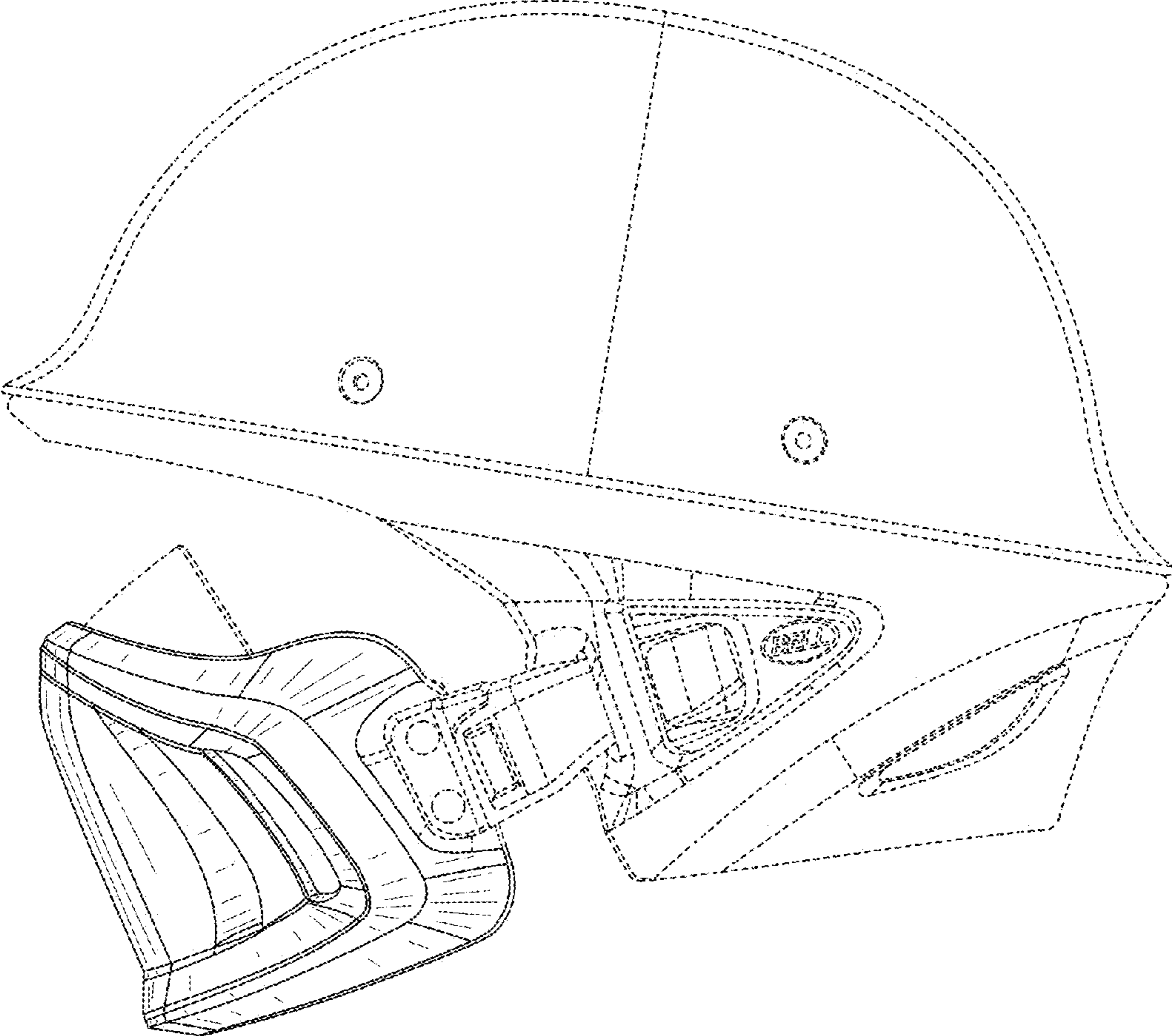

FIG. 2

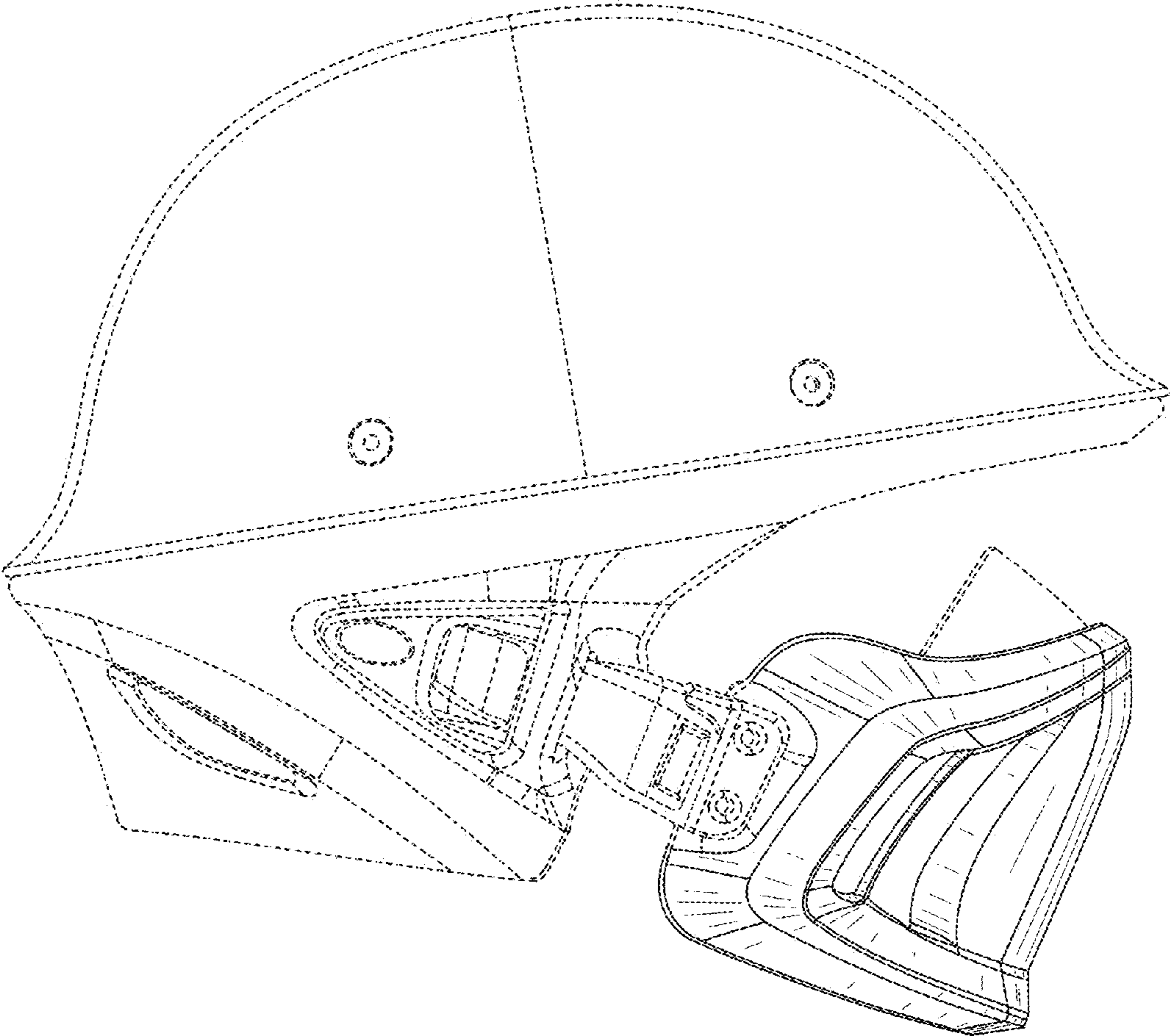

FIG. 3

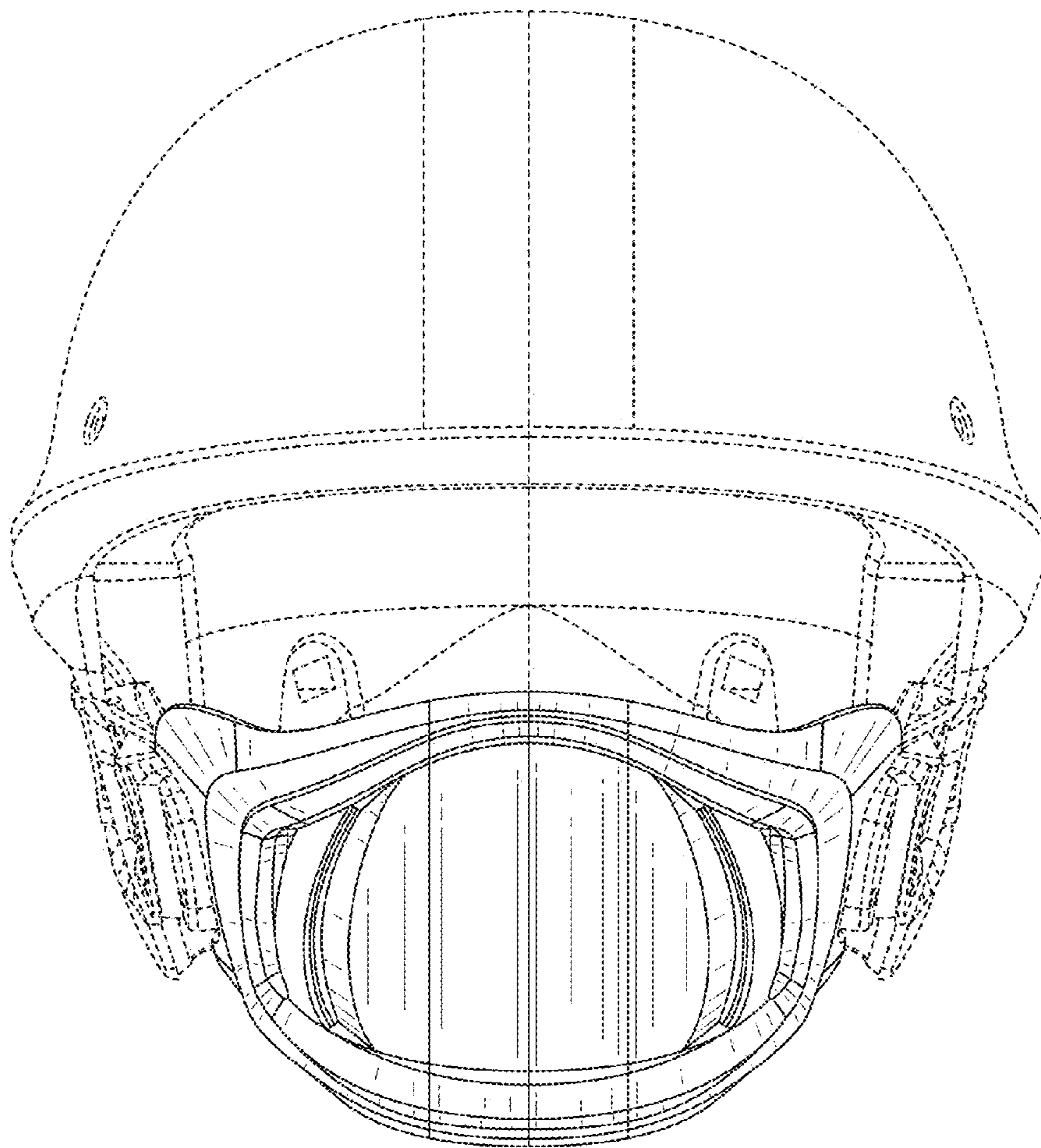

FIG. 4

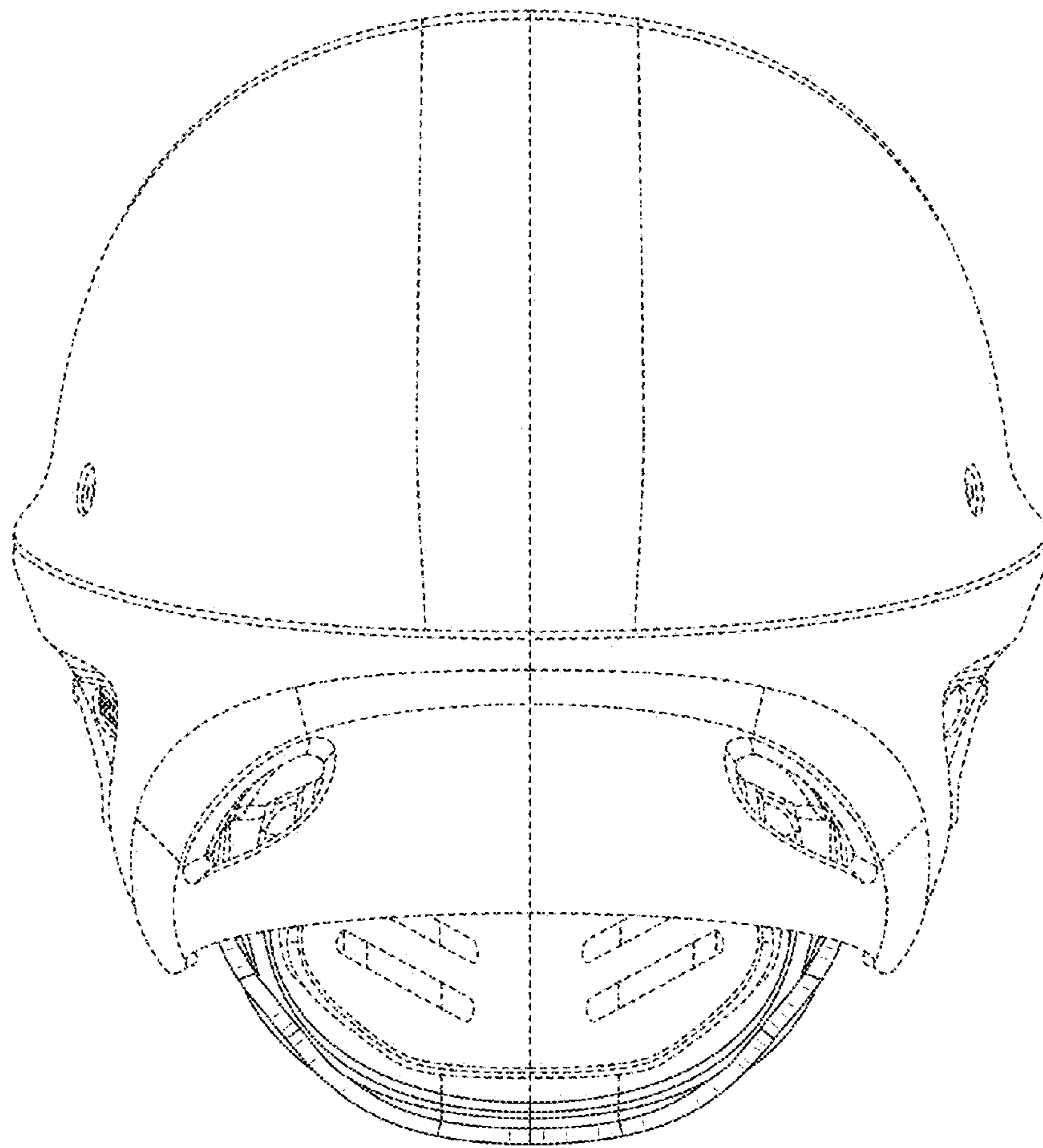

FIG. 5

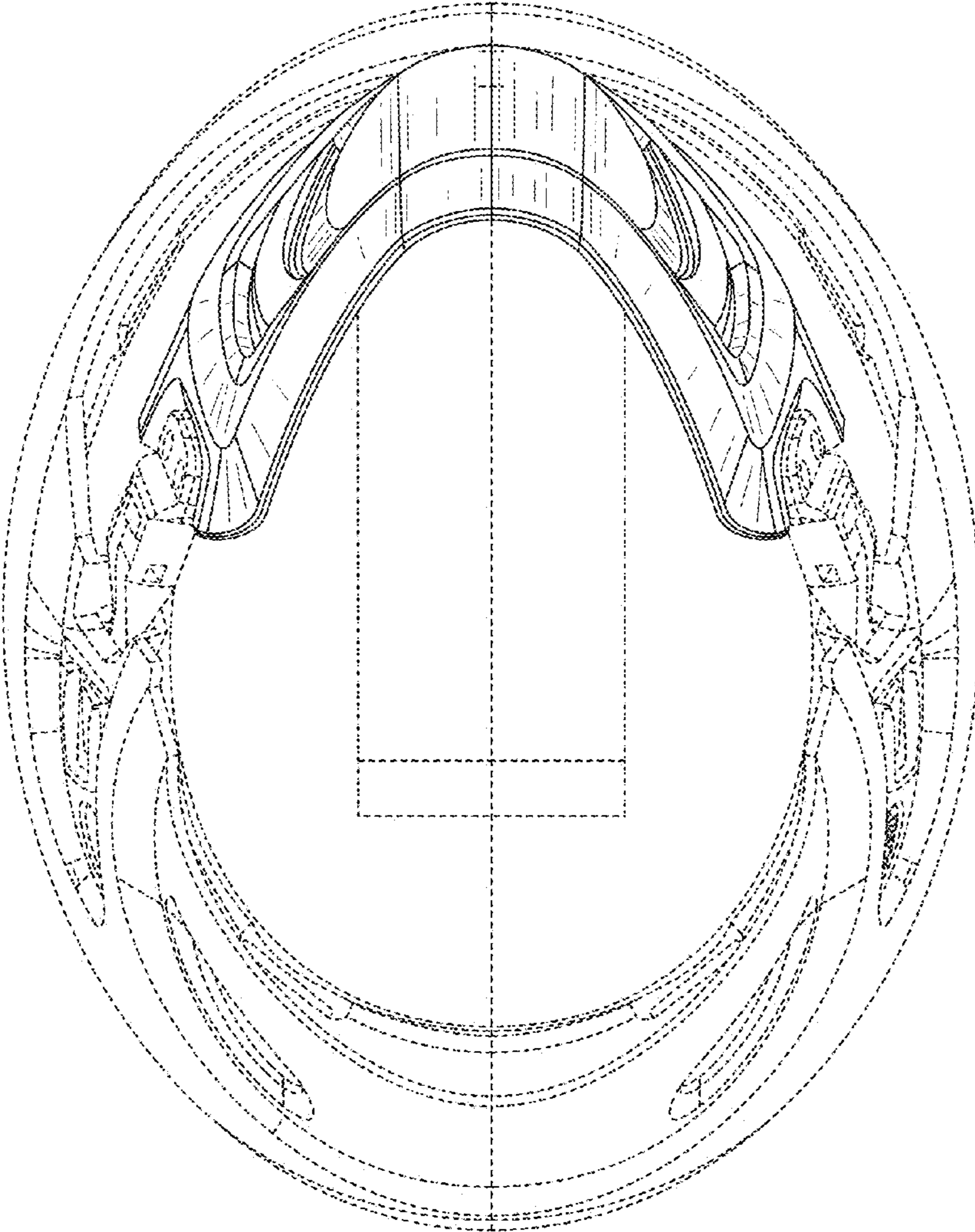

FIG.6

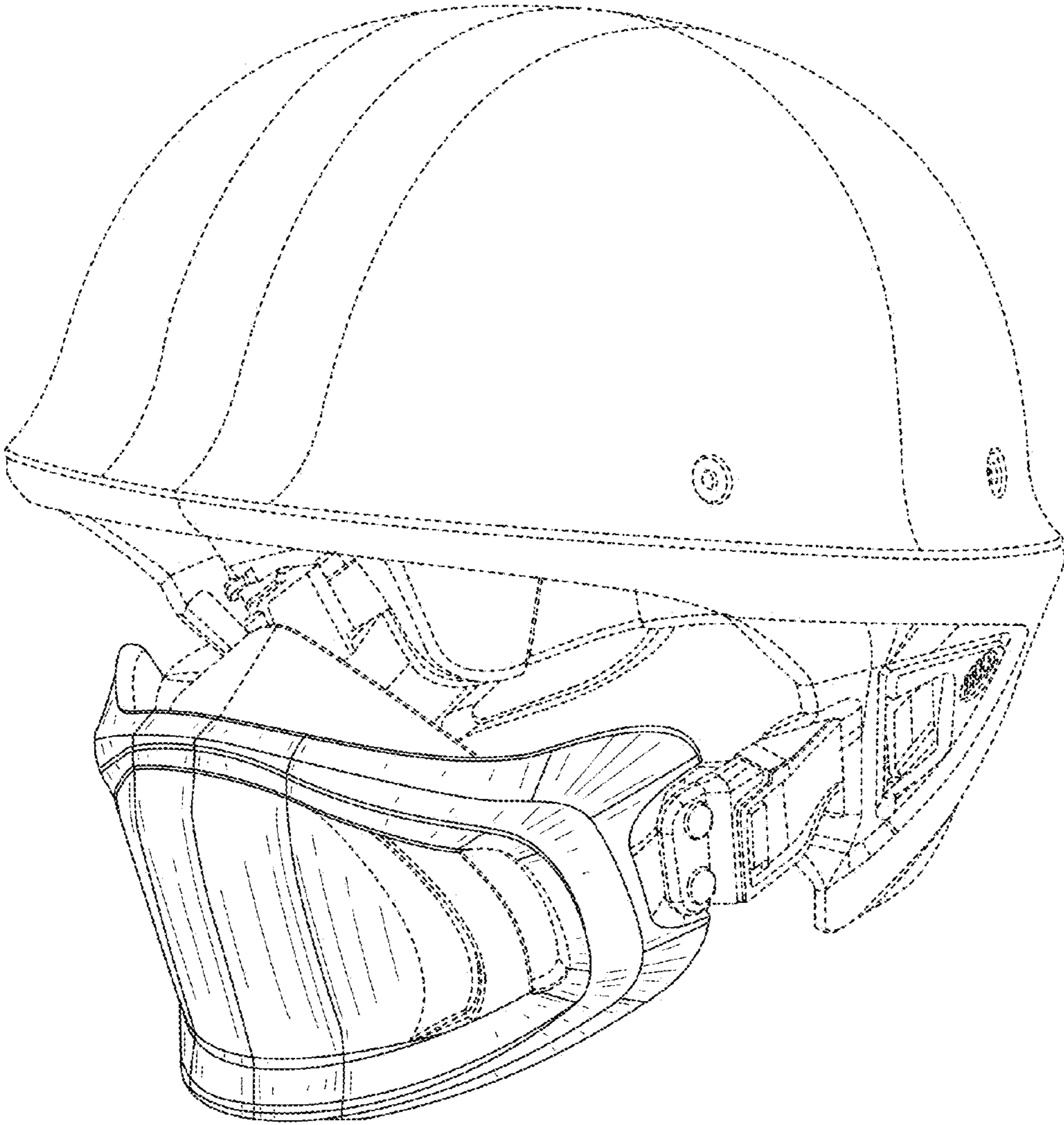

FIG. 7

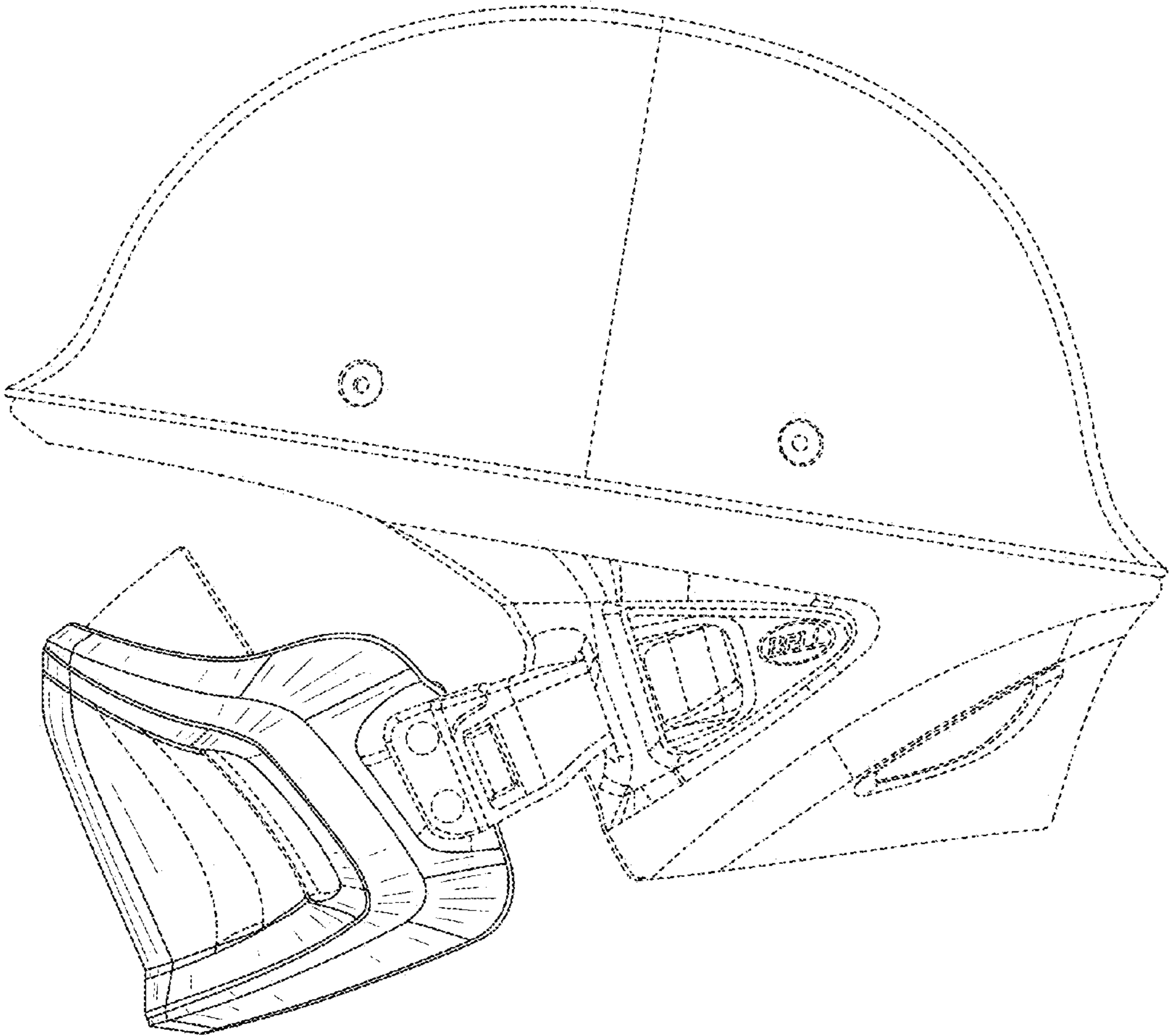

FIG. 8

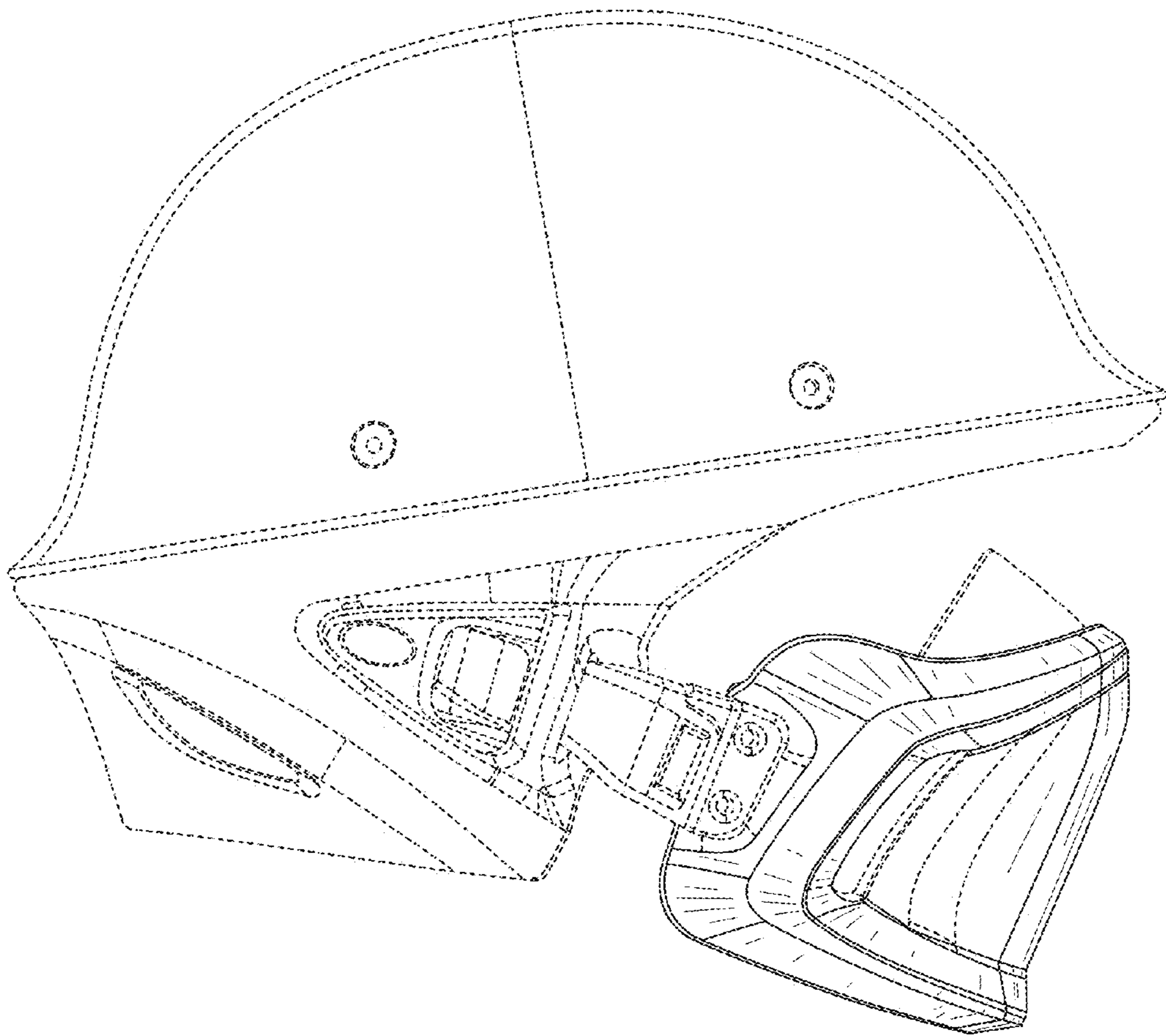

FIG. 9

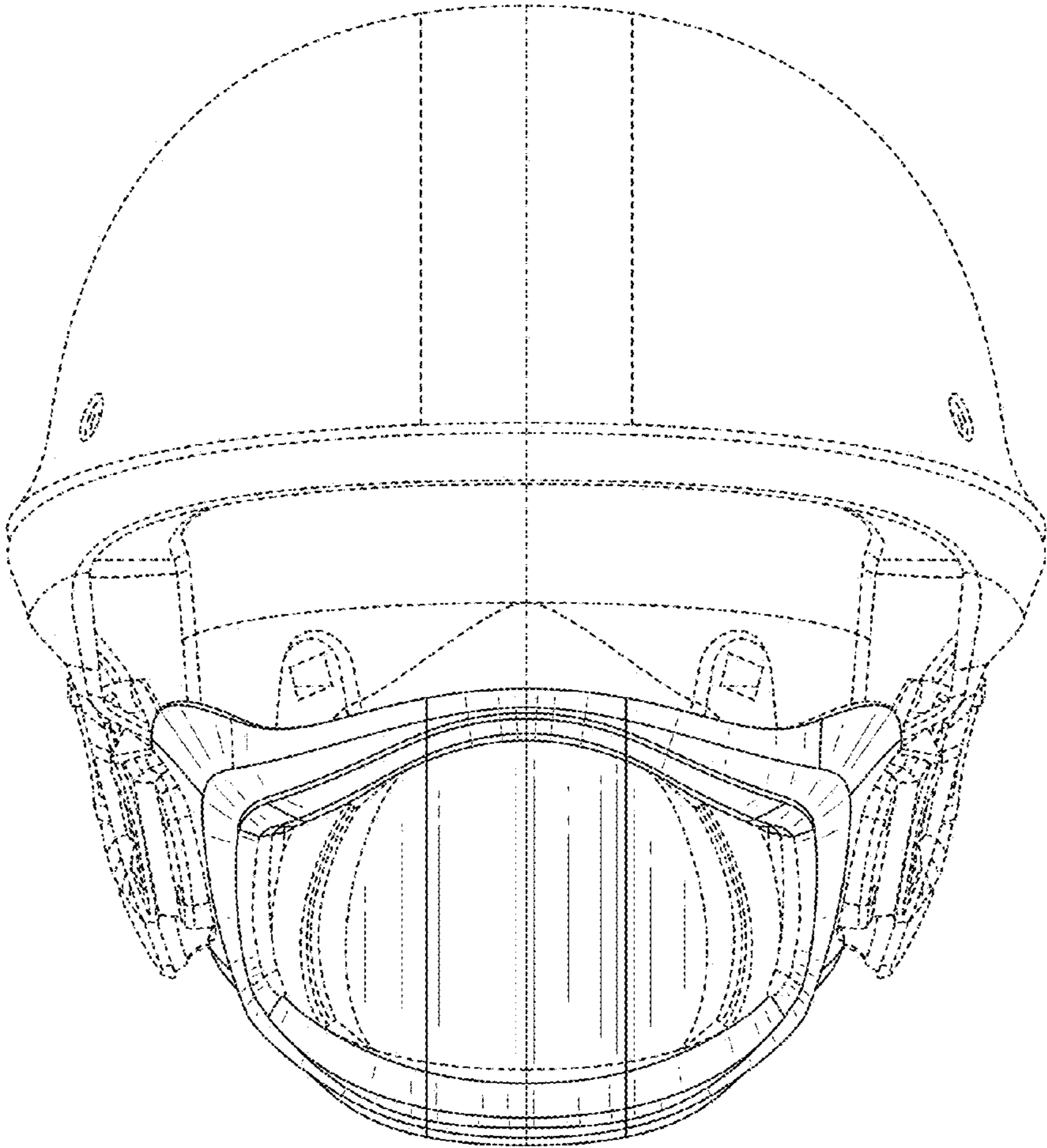

FIG. 10

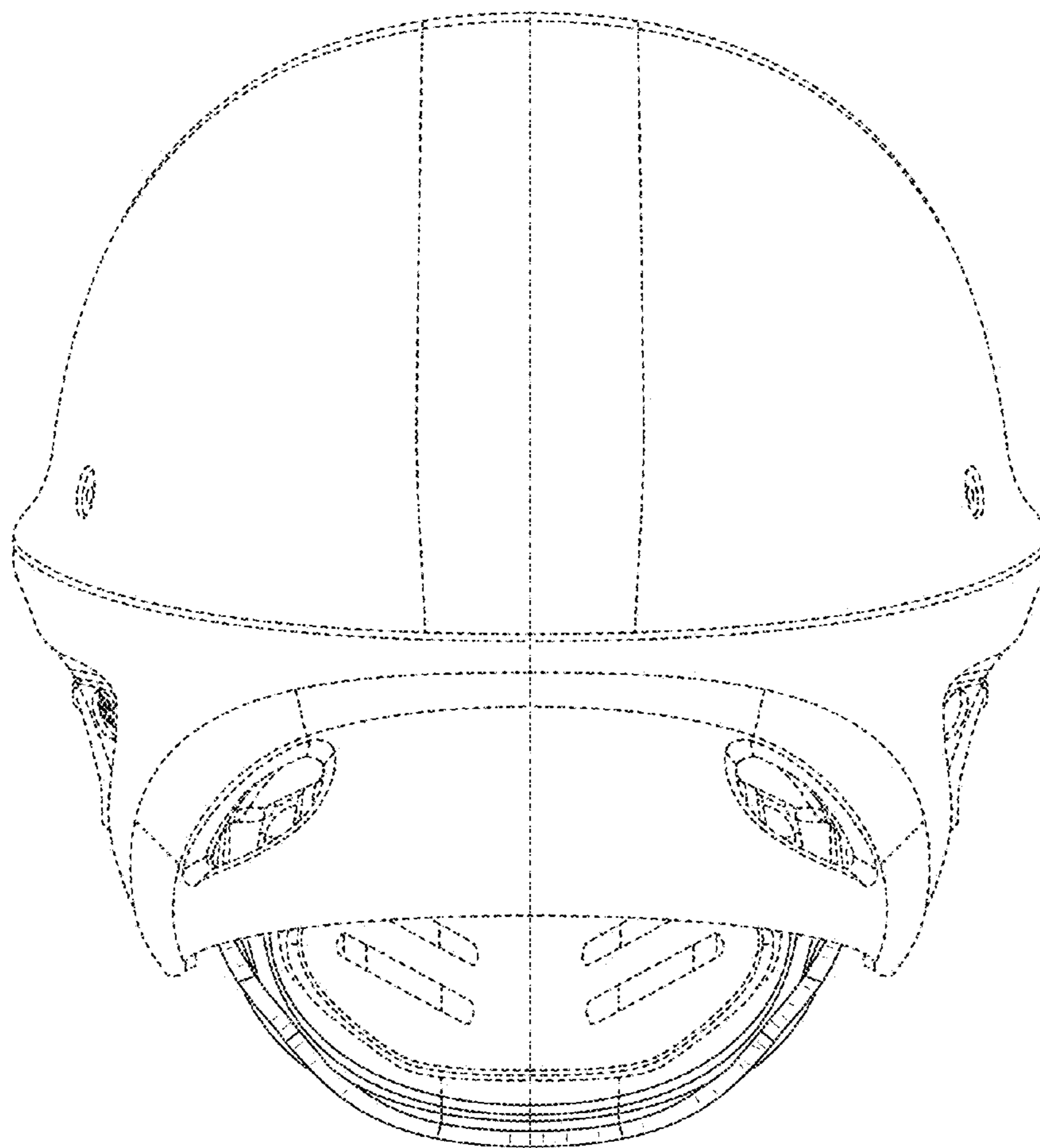

FIG. 11

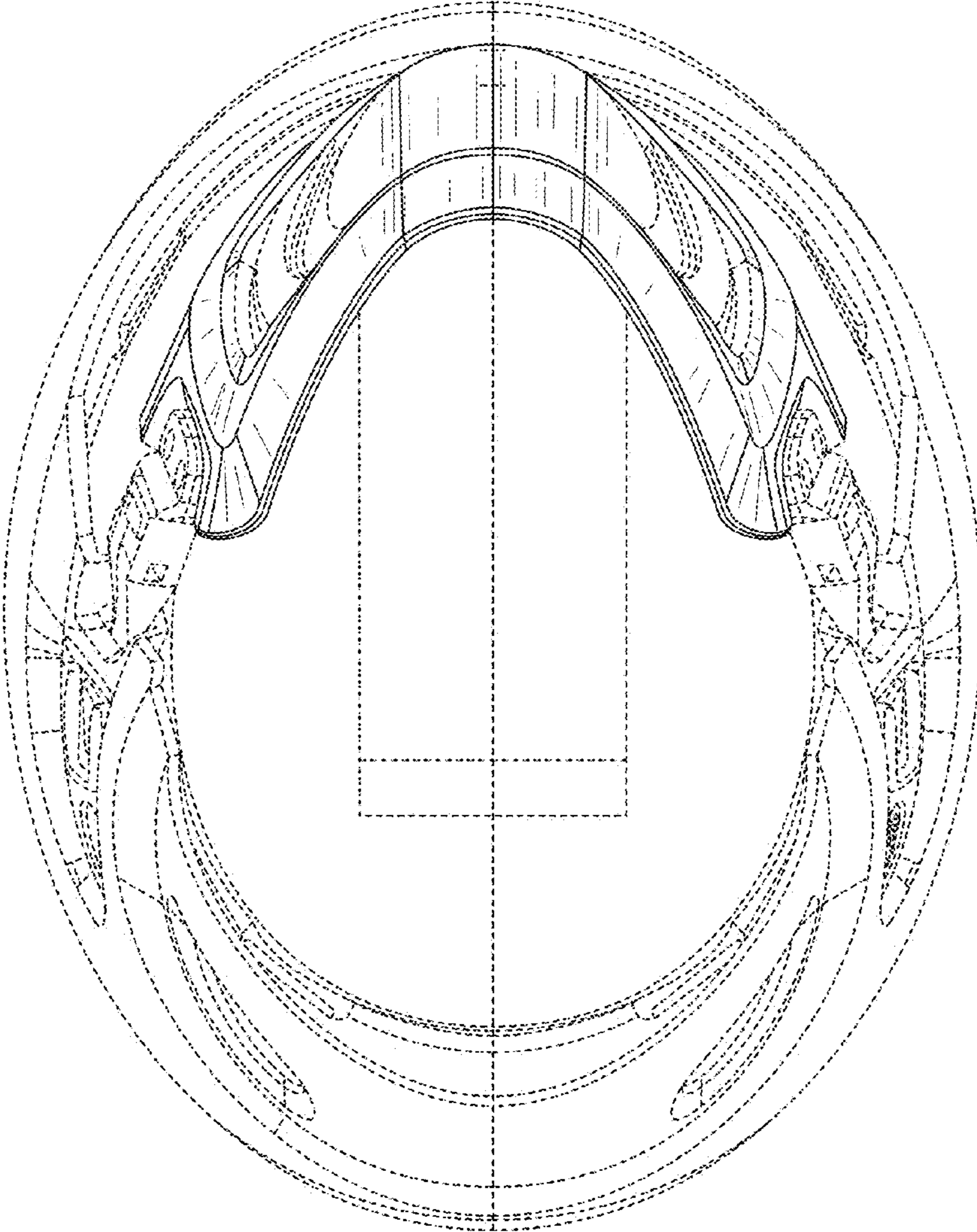

FIG. 12