

US00D724688S

(12) **United States Design Patent**
Hirt et al.

(10) **Patent No.:** **US D724,688 S**
(45) **Date of Patent:** **** Mar. 17, 2015**

- (54) **GRIP FOR SUBMACHINE GUN**
- (71) Applicant: **Sig Sauer, Inc.**, Newington, NH (US)
- (72) Inventors: **Robert Hirt**, Exeter, NH (US); **James Jones**, Manchester, NH (US)
- (73) Assignee: **Sig Sauer, Inc.**, Newington, NH (US)
- (**) Term: **14 Years**
- (21) Appl. No.: **29/470,400**
- (22) Filed: **Oct. 21, 2013**
- (51) **LOC (10) Cl.** **22-01**
- (52) **U.S. Cl.**
USPC **D22/108**
- (58) **Field of Classification Search**
CPC F41C 23/10; F41C 23/14; F41C 23/16;
F41C 23/18
USPC D22/108; 362/109-114; 42/90, 94, 114,
42/117, 124-127, 131, 146
See application file for complete search history.

D636,048	S	4/2011	Larson et al.	
7,966,761	B1	6/2011	Kuczynko et al.	
8,061,072	B1	11/2011	Croze	
8,151,504	B1 *	4/2012	Aiston	42/71.02
8,245,429	B2	8/2012	Kuczynko et al.	
D671,184	S	11/2012	Larson et al.	
D674,859	S	1/2013	Robbins et al.	
8,443,538	B1	5/2013	Moody	
8,522,467	B1	9/2013	Christensen et al.	
D692,517	S *	10/2013	Faifer	D22/108
8,631,601	B2	1/2014	Langevin et al.	
8,667,882	B1	3/2014	Larson et al.	
8,726,558	B1	5/2014	Nason	
8,769,855	B2	7/2014	Law	
D714,413	S	9/2014	Kerbrat et al.	
8,844,185	B2	9/2014	Jarboe	
D716,403	S	10/2014	Burt et al.	
2009/0282718	A1 *	11/2009	Bartley	42/75.03
2010/0186276	A1	7/2010	Herring	
2011/0283581	A1 *	11/2011	Freed	42/49.01
2012/0017482	A1 *	1/2012	Chvala	42/71.01

(Continued)

Primary Examiner — Michael A Pratt
(74) *Attorney, Agent, or Firm* — Finch & Maloney PLLC

(57) **CLAIM**
The ornamental design for a grip for a submachine gun, as shown and described.

(56) **References Cited**

U.S. PATENT DOCUMENTS

2,424,194	A	7/1947	Sampson et al.	
2,970,398	A	2/1961	Crouch	
3,488,488	A	1/1970	Crouch	
3,618,584	A *	11/1971	Pigeon	124/19
4,512,236	A	4/1985	Thevis et al.	
4,617,749	A	10/1986	Jurek	
4,735,007	A	4/1988	Gal	
D344,124	S *	2/1994	Cupp	D22/108
D410,988	S *	6/1999	Hines	D22/108
5,983,774	A	11/1999	Mihaita	
6,839,998	B1	1/2005	Armstrong	
D510,401	S	10/2005	Murello et al.	
D600,310	S *	9/2009	Fitzpatrick et al.	D22/109
D606,155	S	12/2009	Swan	
D606,156	S	12/2009	Swan	
D636,044	S	4/2011	Larson et al.	

DESCRIPTION

FIG. 1 is a left elevation view of a grip for a submachine gun showing the design;
FIG. 2 is a right elevation view thereof;
FIG. 3 is a rear elevation view thereof;
FIG. 4 is a front elevation view thereof;
FIG. 5 is a bottom plan view thereof; and,
FIG. 6 is a front perspective view thereof.
A top plan view has been omitted as it does not form a portion of the claimed design. Broken lines in the drawings are for the purpose of illustrating environmental structure and form no part of the claimed design.

1 Claim, 5 Drawing Sheets

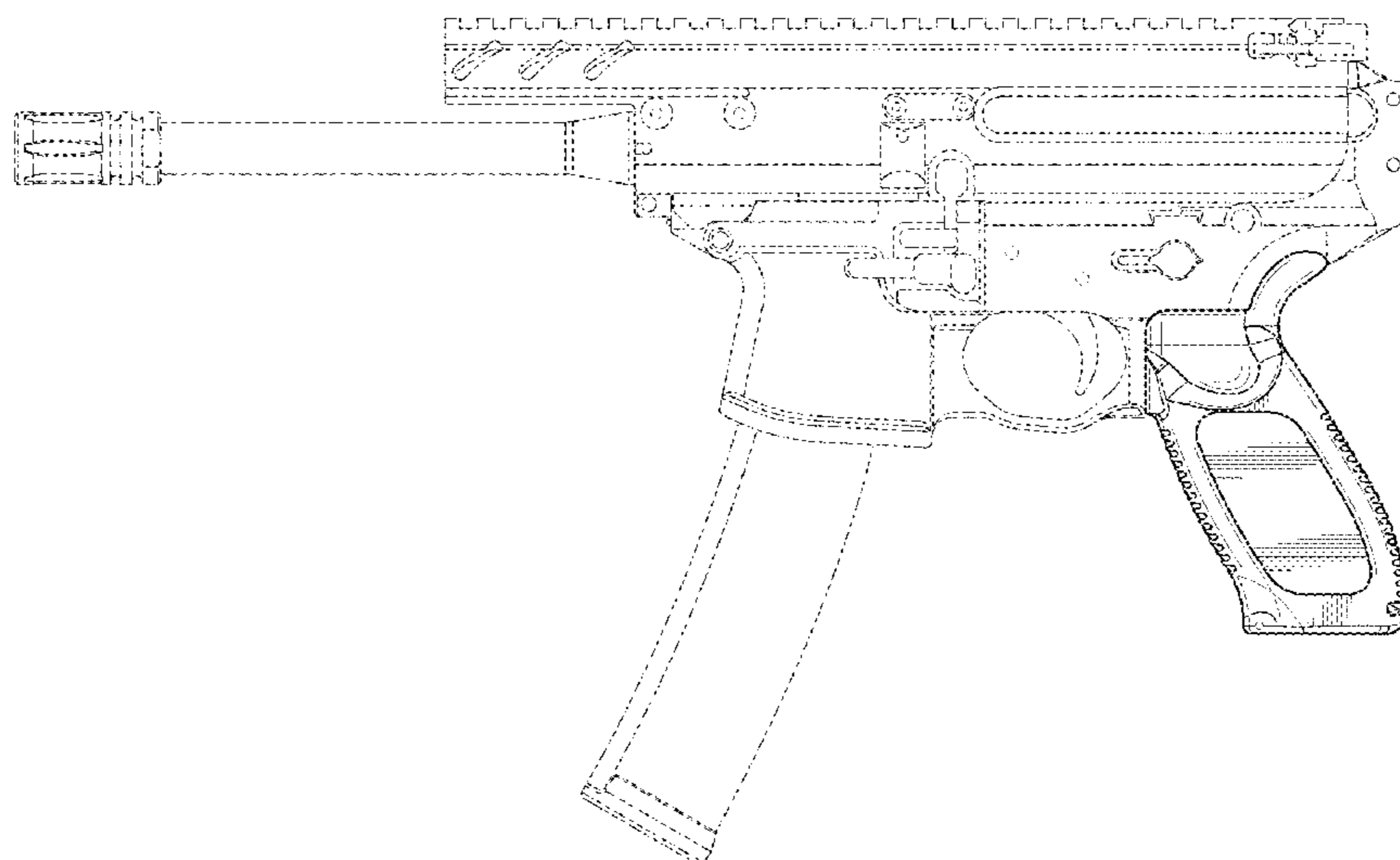

(56)

References Cited

U.S. PATENT DOCUMENTS

2012/0180354 A1	7/2012	Sullivan et al.	2014/0075816 A1	3/2014	Larson et al.
2013/0125442 A1*	5/2013	Burress, Jr. 42/71.01	2014/0196346 A1	7/2014	Grimshaw et al.
2014/0033590 A1	2/2014	Gomez	2014/0260946 A1	9/2014	Gomez

* cited by examiner

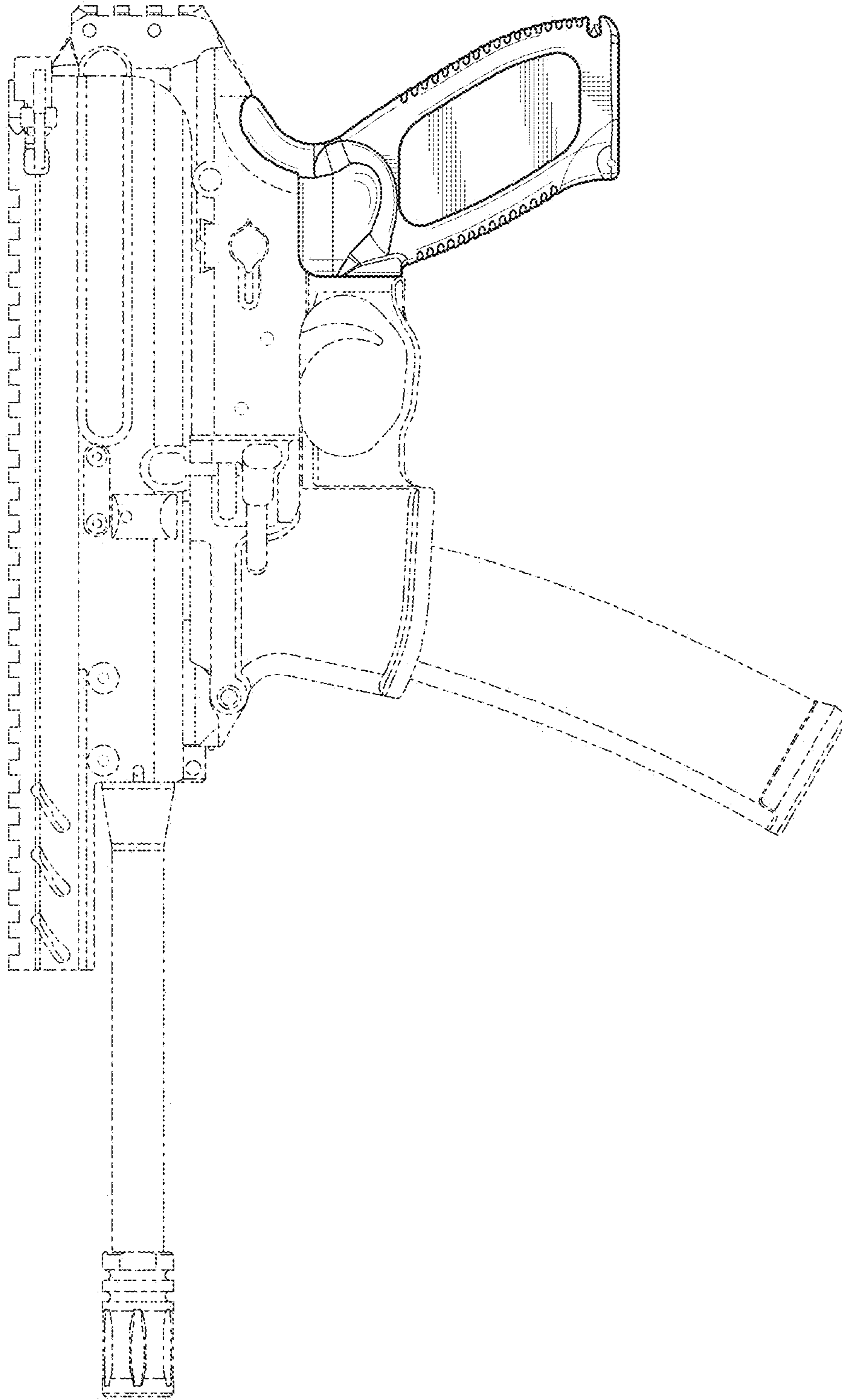

FIG. 1

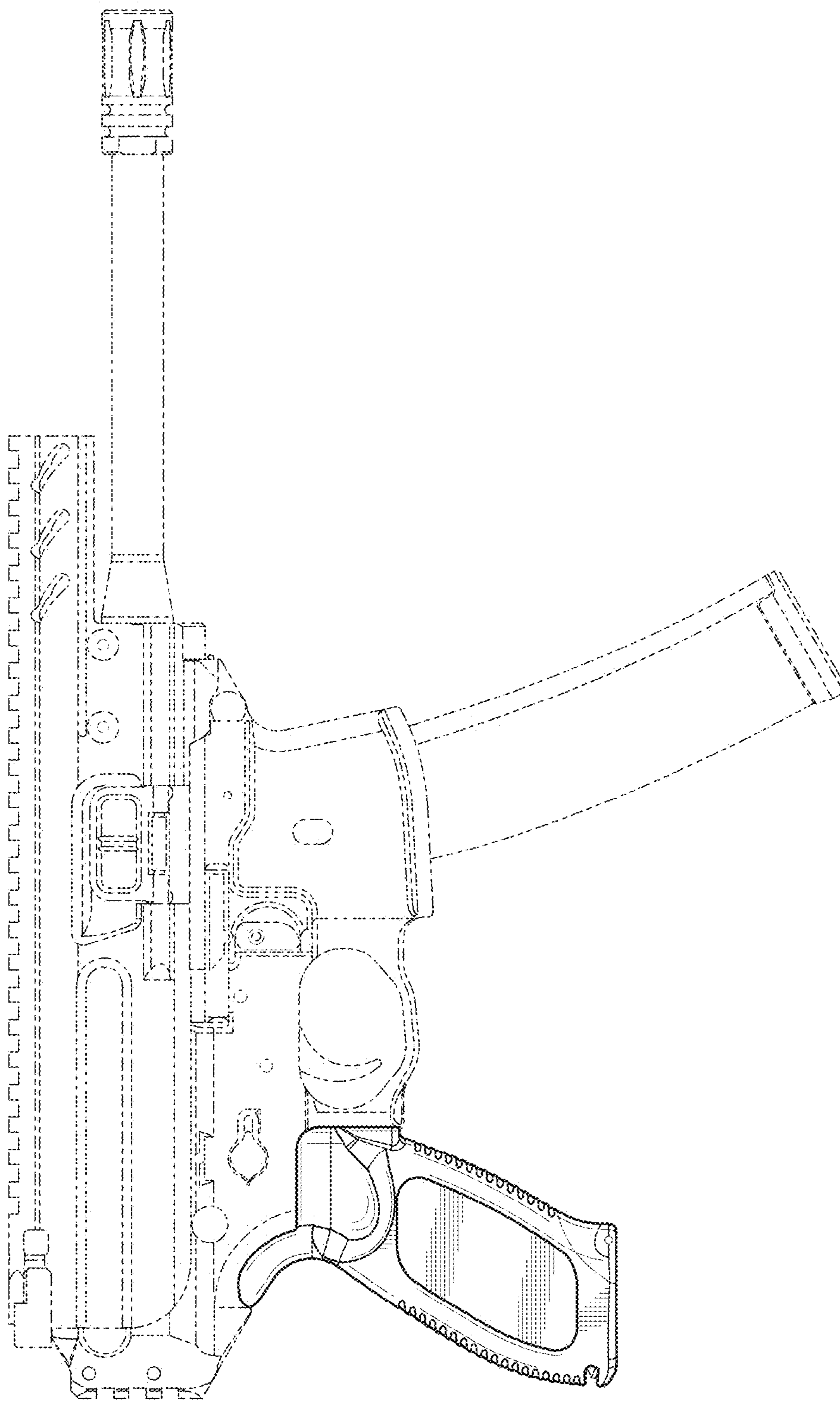

FIG. 2

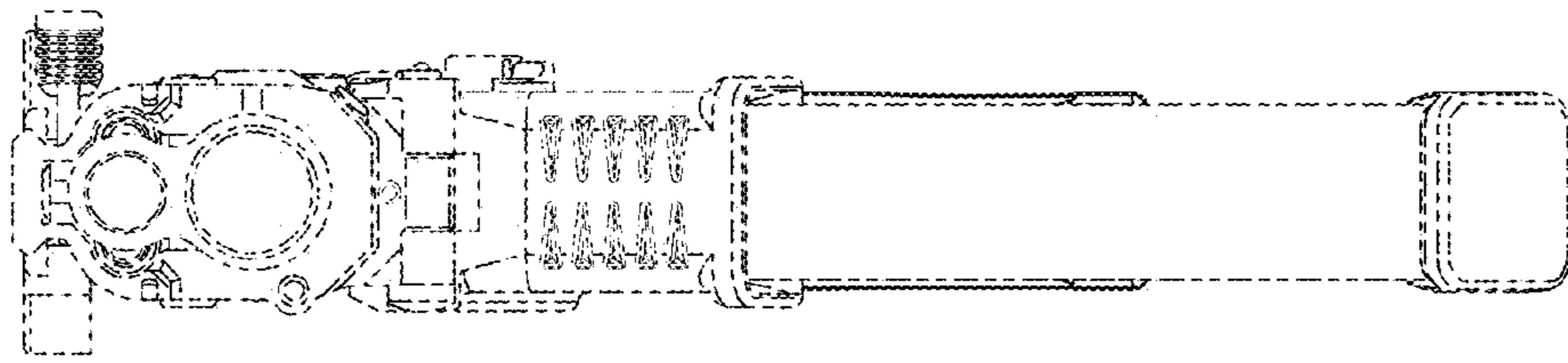

FIG. 4

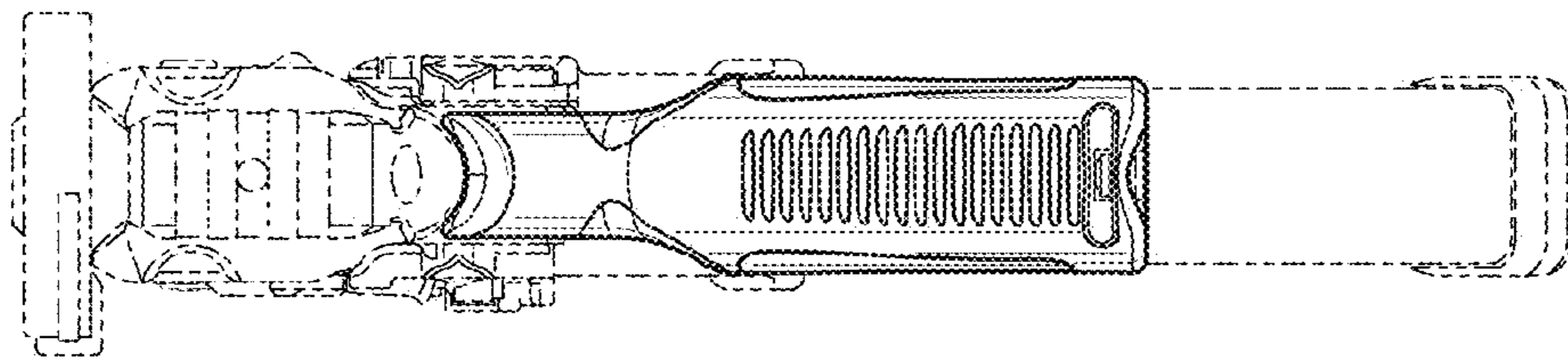

FIG. 3

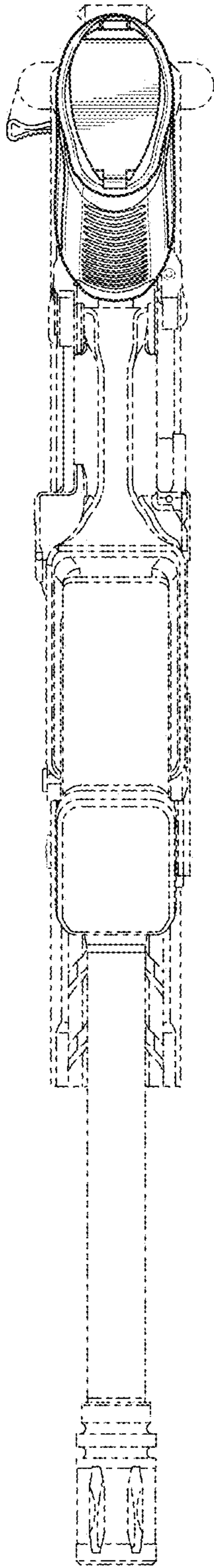

FIG. 5

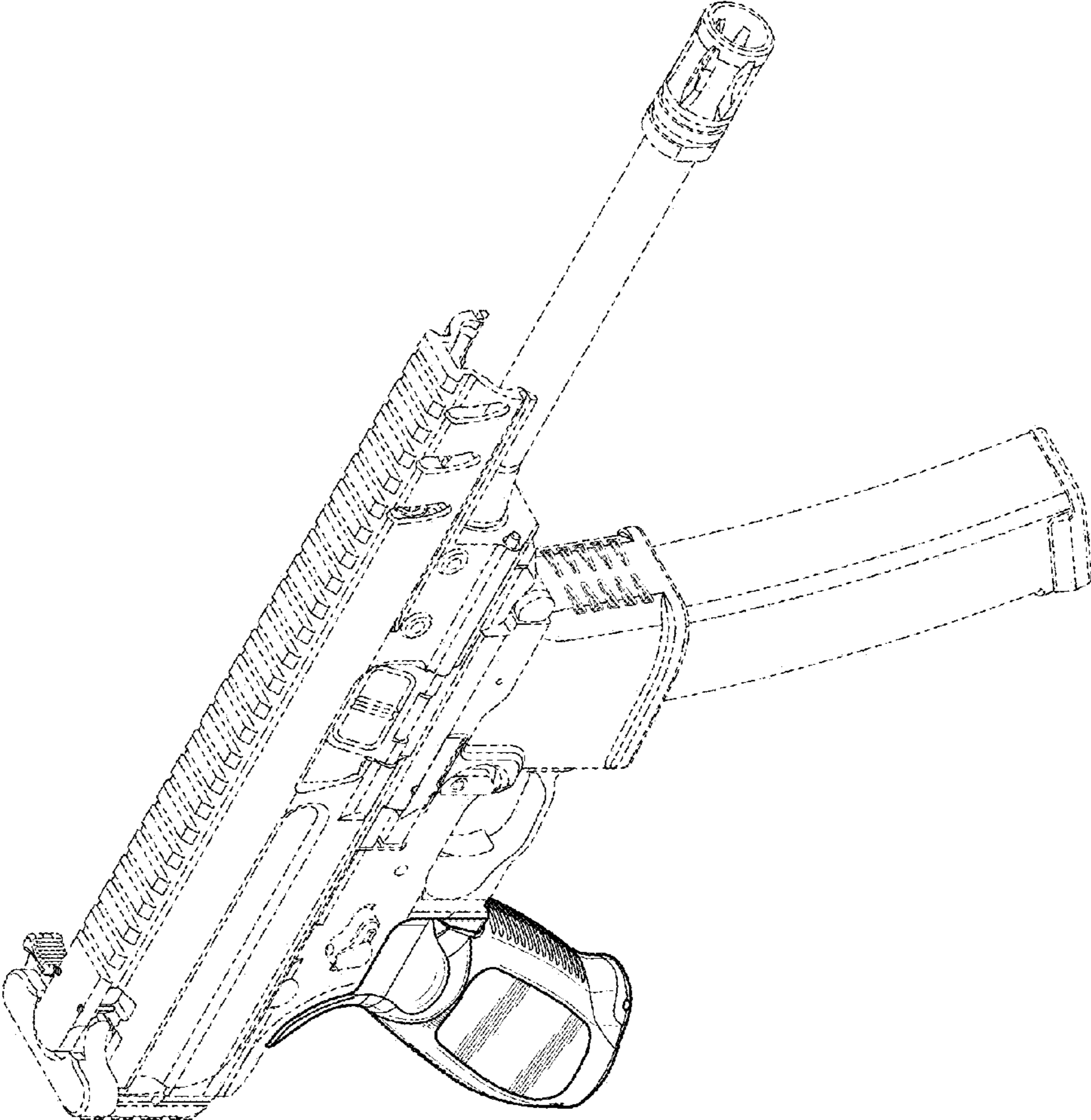

FIG. 6