

US00D724339S

(12) **United States Design Patent**  
**Cai et al.**

(10) **Patent No.:** **US D724,339 S**  
(45) **Date of Patent:** **\*\* Mar. 17, 2015**

(54) **AIRCRAFT SEAT**

(71) Applicant: **SuperAlloy Industrial Co., Ltd.**,  
Yun-Lin County (TW)

(72) Inventors: **Deng Chuan Cai**, Yun-Lin County (TW);  
**Chu Wei Chen**, Yun-Lin County (TW);  
**Henry Shih**, Yun-Lin County (TW);  
**Wen Ping Tsai**, Yun-Lin County (TW);  
**Kuan Ling Liao**, Yun-Lin County (TW)

(73) Assignee: **SuperAlloy Industrial Co., Ltd.**,  
Yun-Lin County (TW)

(\*\*) Term: **14 Years**

(21) Appl. No.: **29/486,354**

(22) Filed: **Mar. 28, 2014**

(51) **LOC (10) Cl.** ..... **06-01**

(52) **U.S. Cl.**  
USPC ..... **D6/356**

(58) **Field of Classification Search**  
CPC ..... B60N 3/004; B60N 2/075; B60N 2/4879;  
B60N 2/70; A47C 7/70; A47C 1/124; A47C  
7/40; A47C 7/543; A47C 7/022; B64D 11/06  
USPC ..... D6/334-336, 356, 367, 368, 374, 716,  
D6/716.1, 716.2, 716.3, 716.4; 297/163,  
297/188.04, 248, 344.1, 353, 394, 411.29,  
297/452.24, 452.35; 244/122 R  
See application file for complete search history.

(56) **References Cited**

U.S. PATENT DOCUMENTS

D198,498 S \* 6/1964 Malitte ..... D6/356  
D210,363 S \* 3/1968 Barecki ..... D6/356  
3,374,032 A \* 3/1968 Del Giudice ..... B64D 11/06  
3,563,604 A \* 2/1971 Barecki ..... A47C 7/543  
3,695,707 A \* 10/1972 Barecki et al. .... B64D 11/06  
D250,071 S \* 10/1978 Dickerson ..... D6/356

D257,918 S \* 1/1981 Reida et al. .... D6/356  
D267,372 S \* 12/1982 Long et al. .... D6/356  
D268,880 S \* 5/1983 Palmgren ..... D6/356  
4,526,421 A \* 7/1985 Brennan et al. .... B64D 11/06  
D336,379 S \* 6/1993 Veneruso ..... D6/356  
5,364,164 A \* 11/1994 Kuranami ..... B64D 11/06  
5,597,139 A \* 1/1997 Beroth ..... B64D 11/06  
5,695,240 A \* 12/1997 Luria ..... B60N 3/004  
6,241,188 B1 \* 6/2001 Simpson et al. .... B60N 3/004  
7,506,930 B2 \* 3/2009 Penley et al. .... B64D 11/06  
D605,863 S \* 12/2009 Aruga et al. .... D6/356  
8,020,936 B2 \* 9/2011 Asami et al. .... A47C 7/40  
8,596,724 B1 \* 12/2013 Ahad ..... B64D 11/06  
8,613,479 B2 \* 12/2013 Schurg et al. .... B60N 3/004  
8,636,003 B2 \* 1/2014 Deutscher et al. .... B64D 11/06  
8,826,830 B2 \* 9/2014 Pajic ..... B64D 11/06

\* cited by examiner

*Primary Examiner* — Mimoso De

(74) *Attorney, Agent, or Firm* — Rosenberg, Klein & Lee

(57) **CLAIM**

The ornamental design for an aircraft seat, as shown and described.

**DESCRIPTION**

FIG. 1 is a perspective view of the aircraft seat;  
FIG. 2 is a front elevation view thereof;  
FIG. 3 is a rear elevation view thereof;  
FIG. 4 is a left side elevation view thereof;  
FIG. 5 is a right side elevation view thereof;  
FIG. 6 is a top plan view thereof;  
FIG. 7 is a bottom plan view thereof;  
FIG. 8 is a left rear perspective view thereof; and,  
FIG. 9 is an additional perspective view thereof, taken from front, right side, showing the aircraft seat unit in accordance with our design.  
The broken line shown in FIG. 9 is included for the purpose of illustrating environment of the article and forms no part of the claimed design.

**1 Claim, 9 Drawing Sheets**

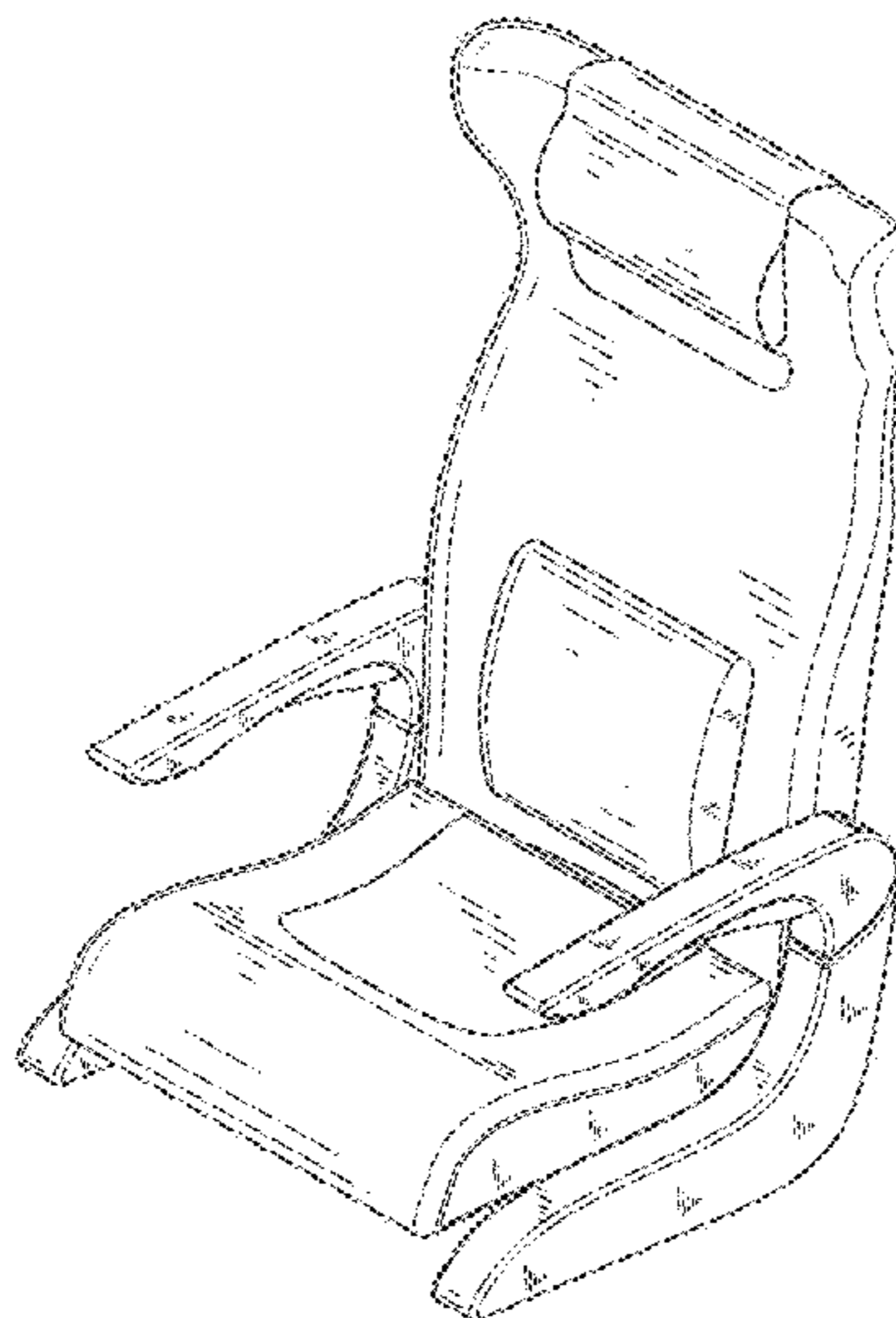

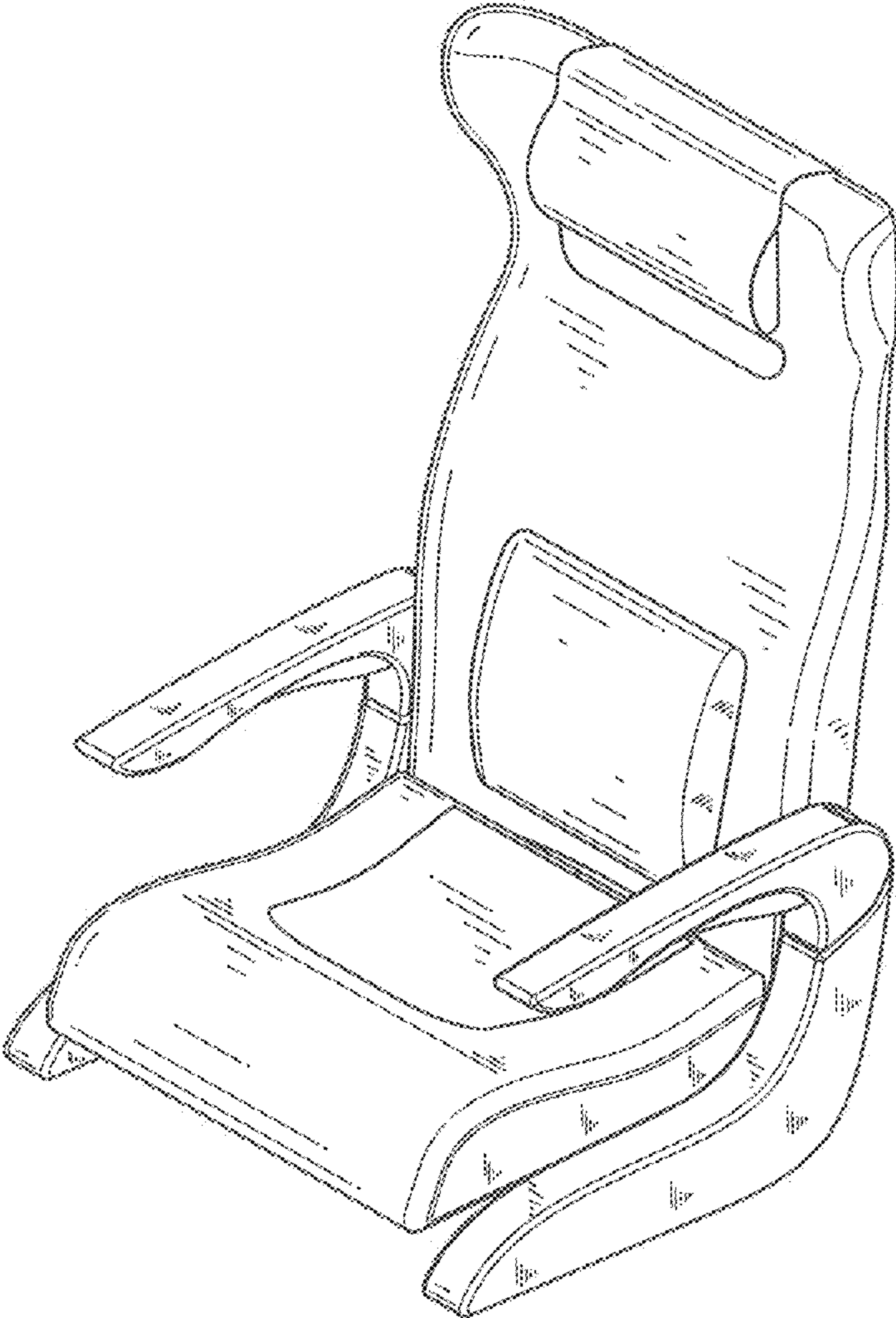

FIG.1

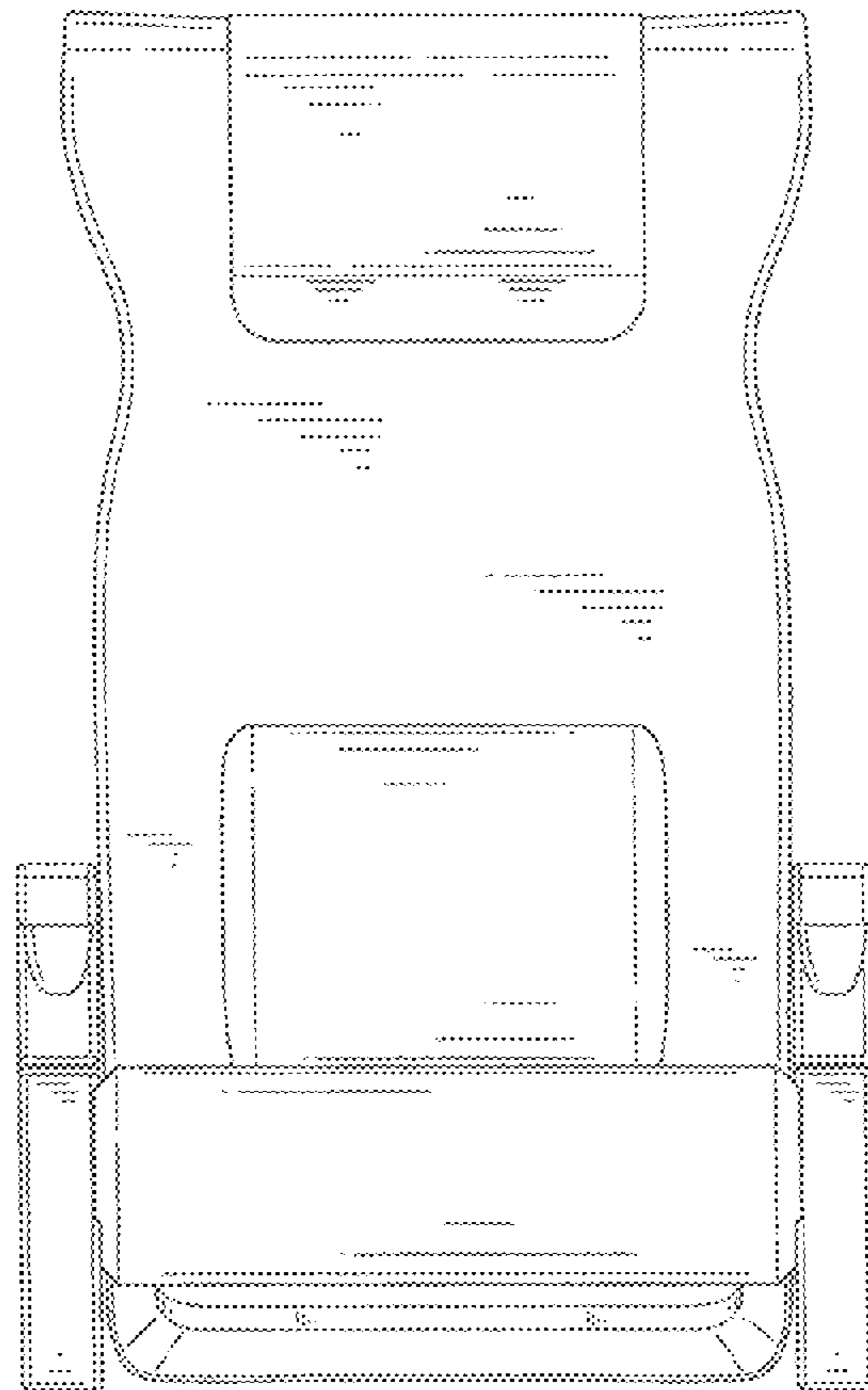

FIG.2

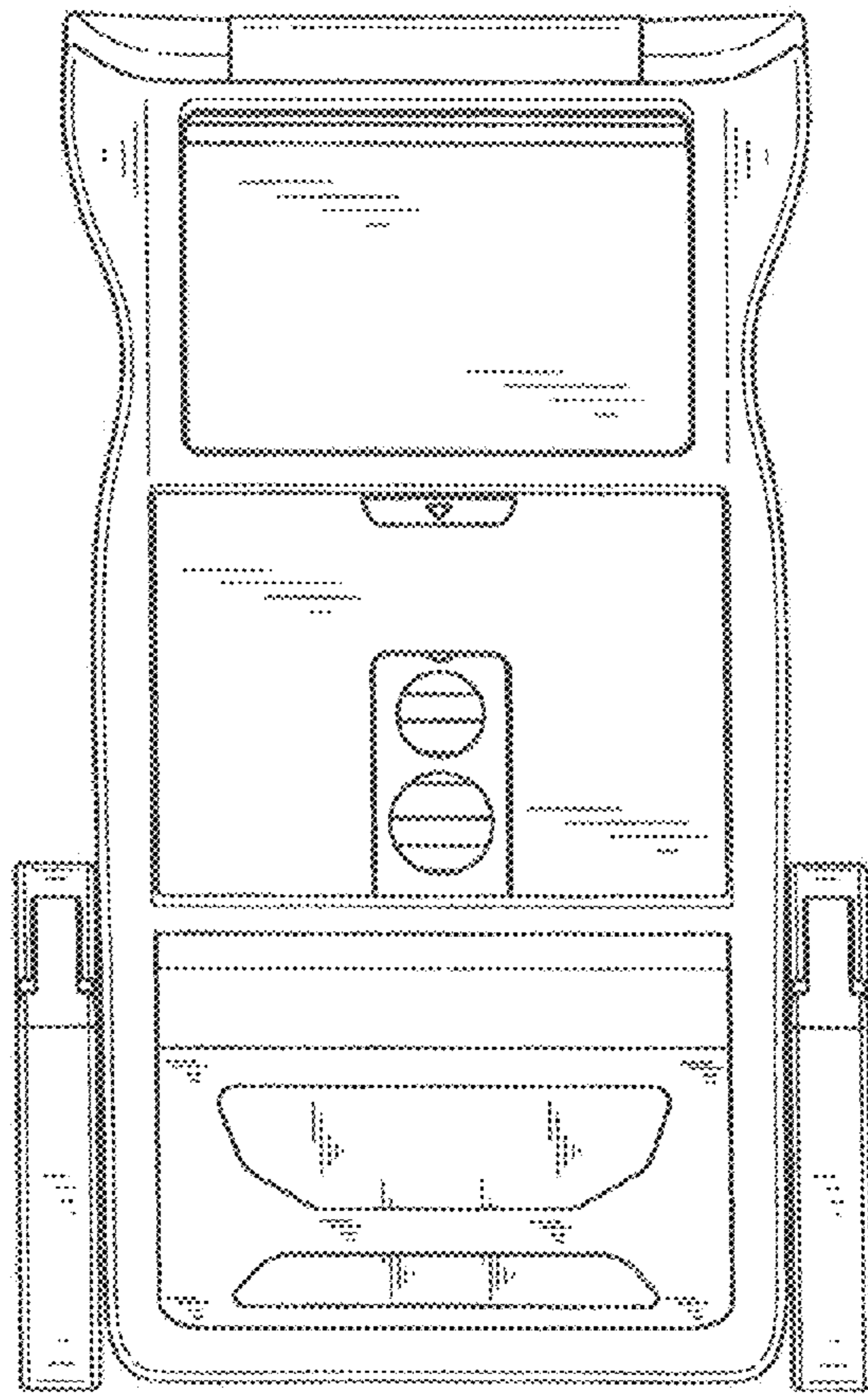

FIG. 3

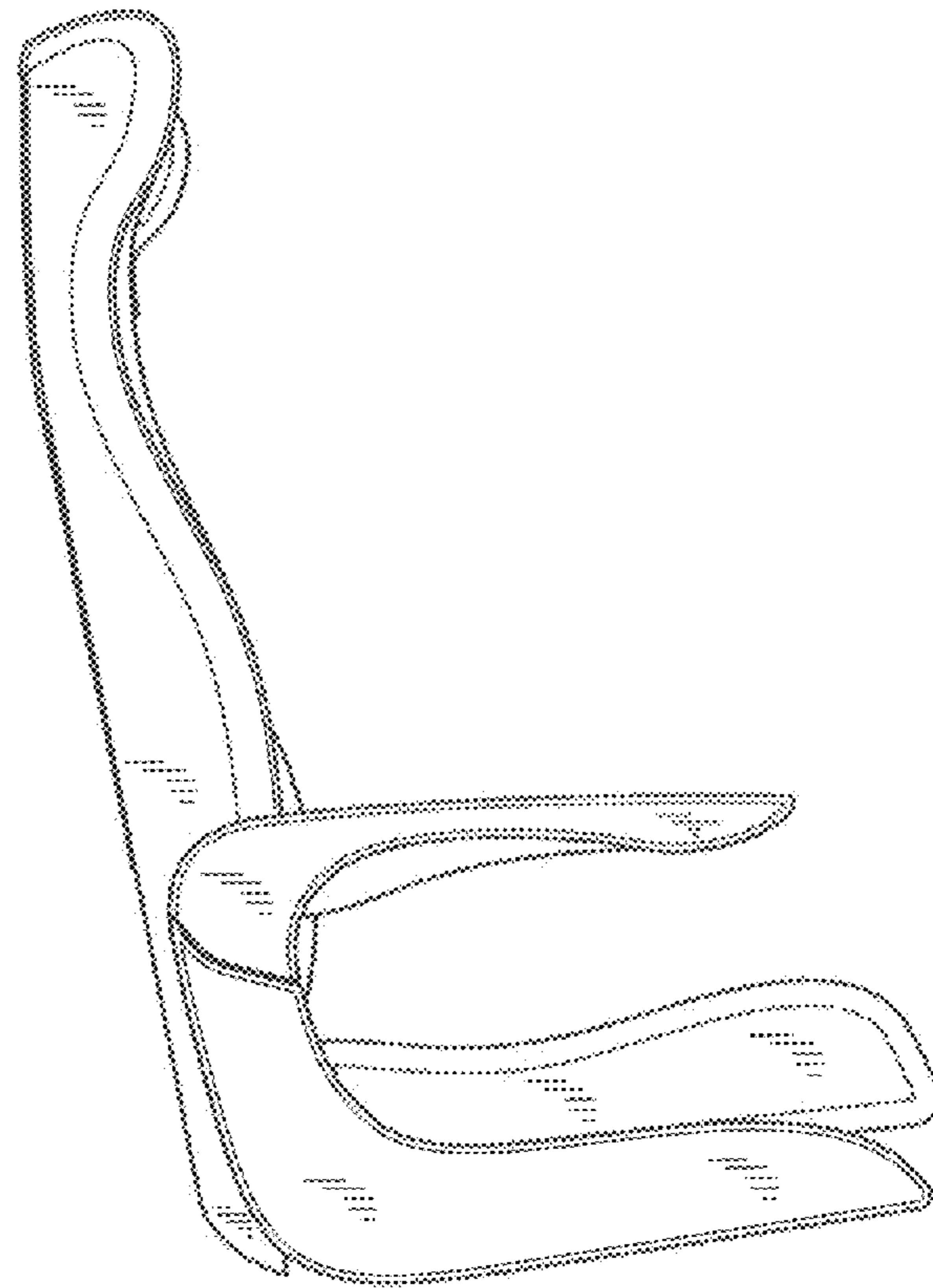

FIG. 4

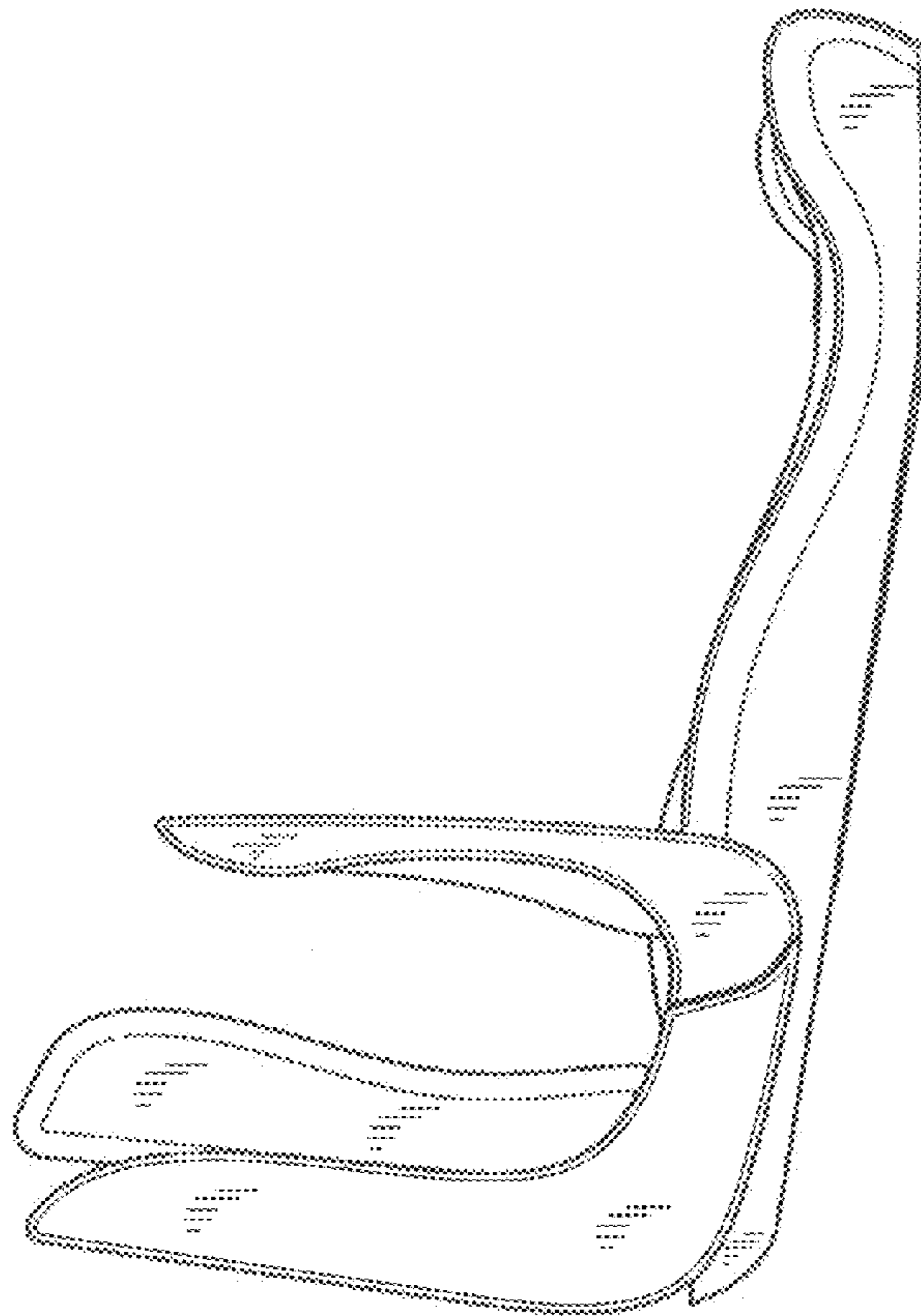

FIG. 5

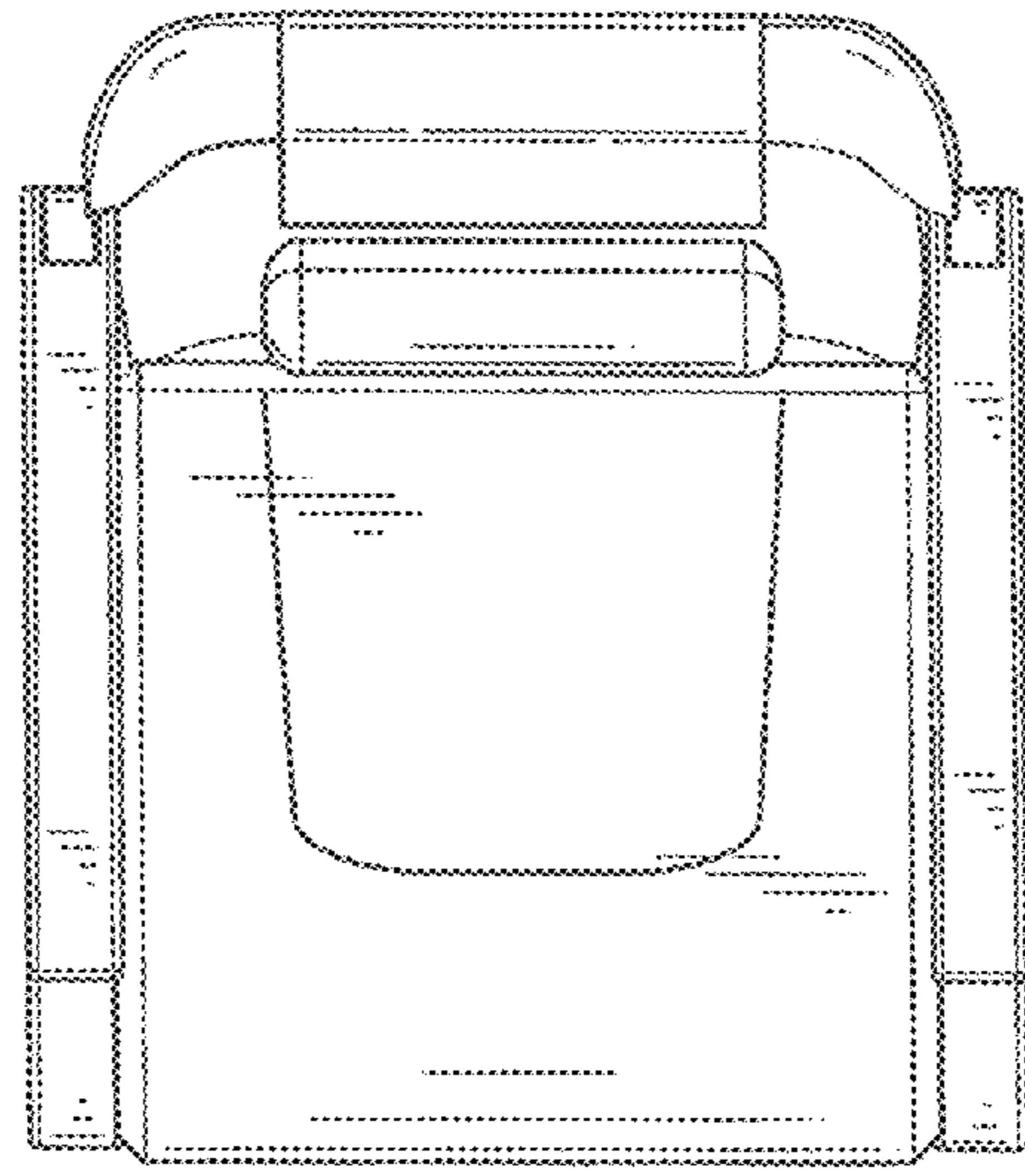

FIG.6

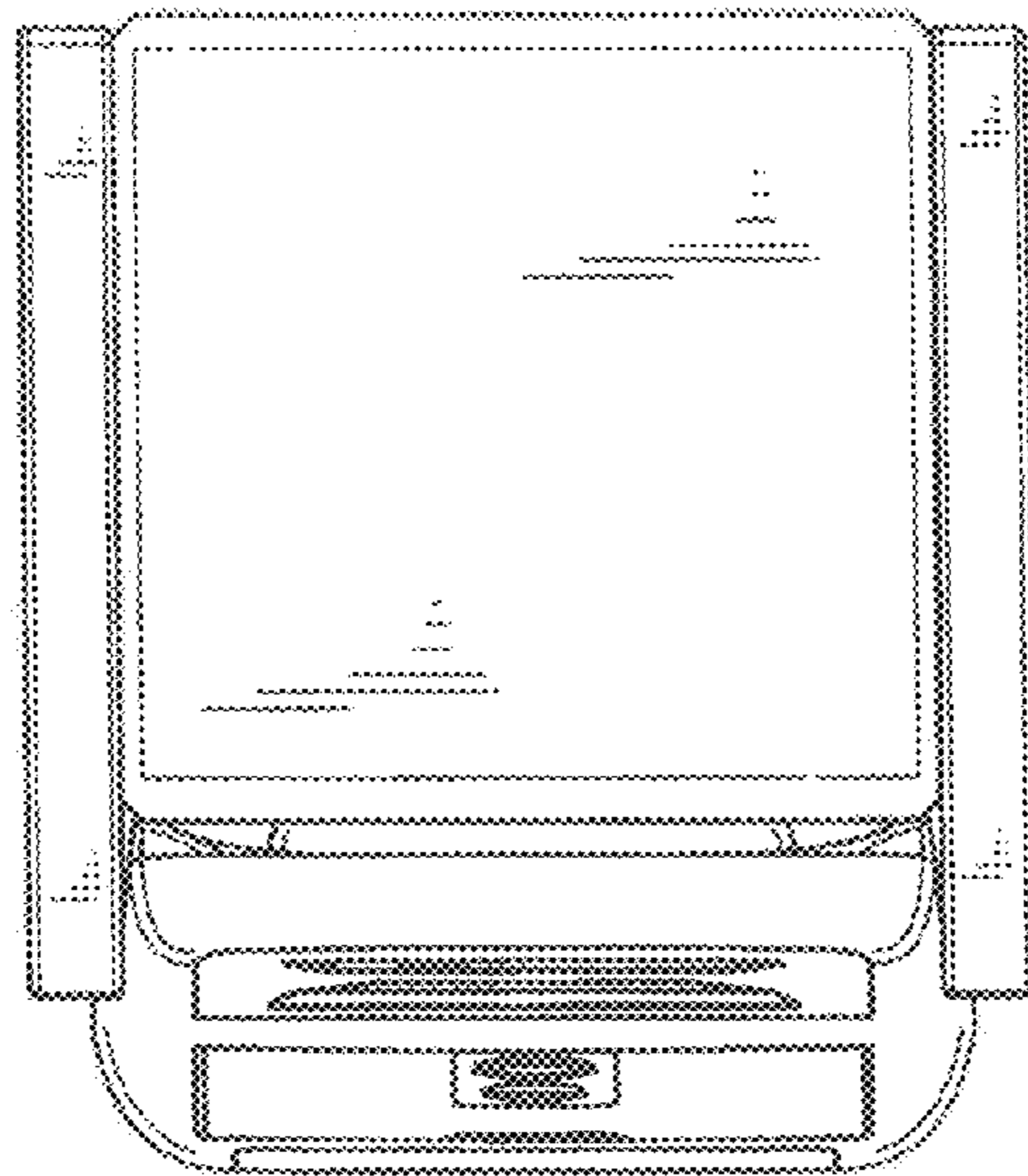

FIG. 7



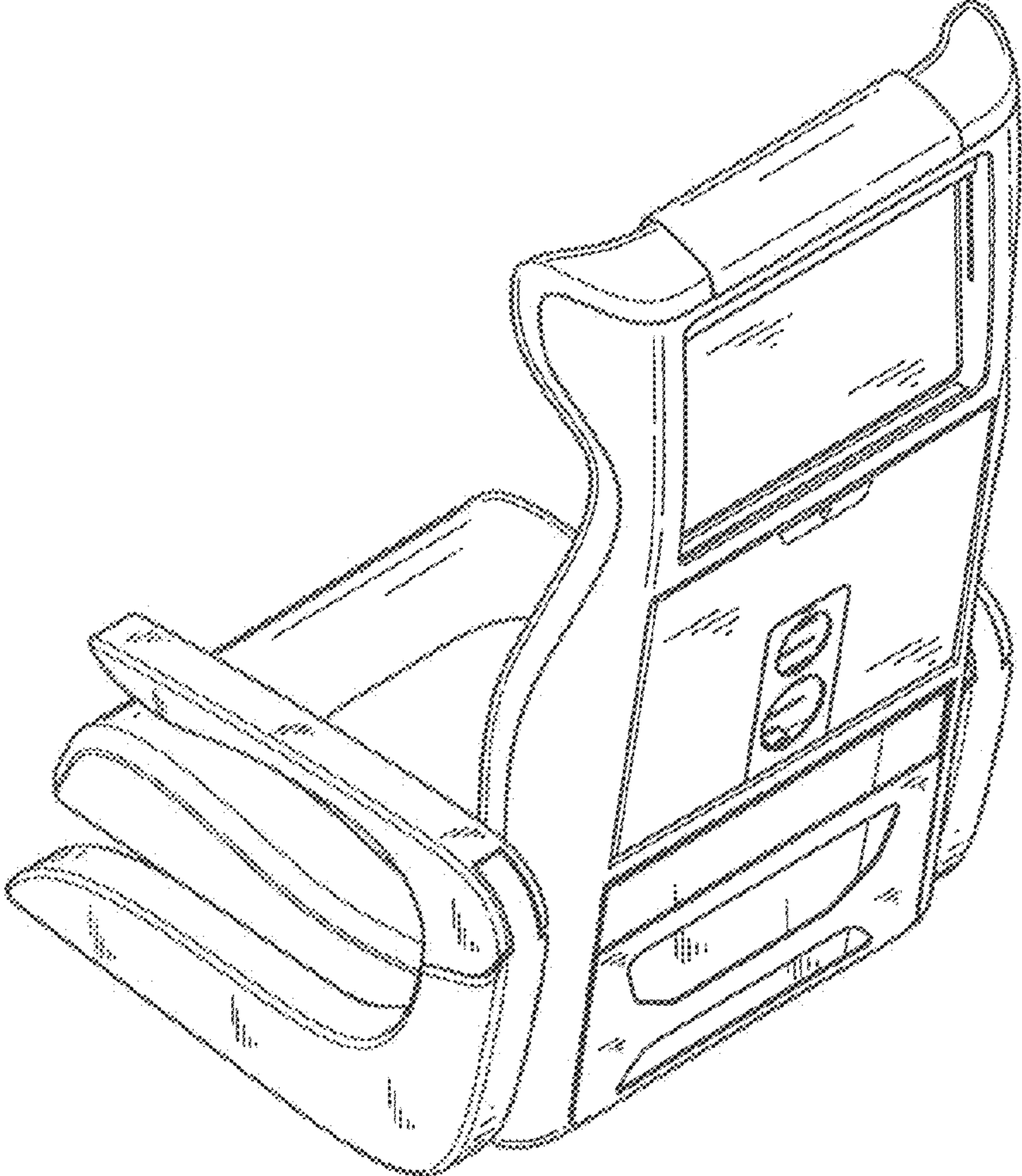

FIG.8

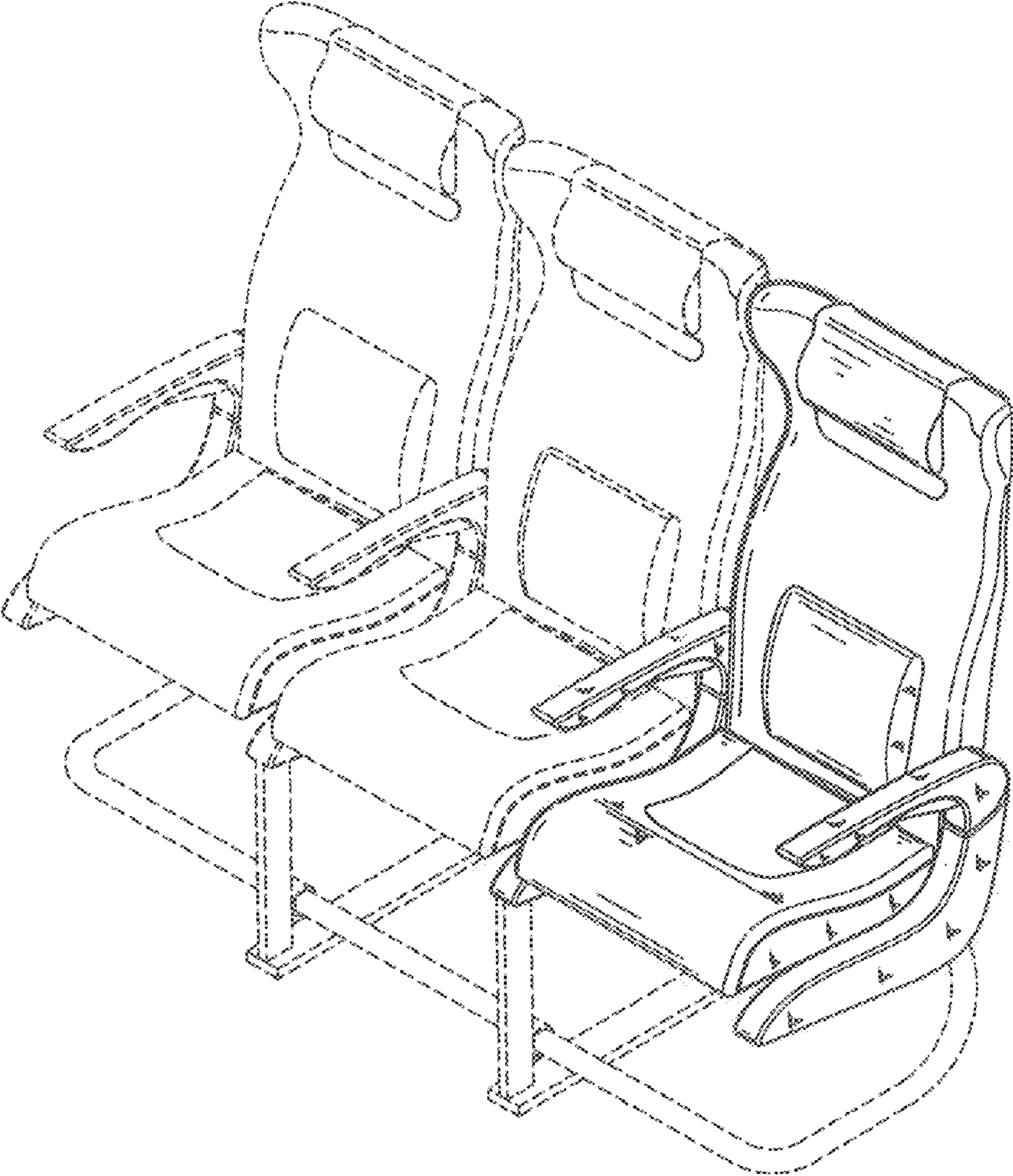

FIG.9