



US00D724329S

(12) **United States Design Patent**
Toll

(10) **Patent No.:** **US D724,329 S**
(45) **Date of Patent:** **** Mar. 17, 2015**

(54) **BICYCLE SEAT**

612,972 A 10/1898 Leech
D29,719 S 11/1898 Leech et al.
619,204 A 2/1899 Moore

(71) Applicant: **Tampa Bay Recreation, LLC**, Lutz, FL
(US)

(Continued)

(72) Inventor: **Steven G. Toll**, Tampa, FL (US)

FOREIGN PATENT DOCUMENTS

(73) Assignee: **Tampa Bay Recreation, LLC**, Lutz, FL
(US)

JP 2007186075 A * 7/2007 B62J 1/00
JP 2008-509047 3/2008

(Continued)

(**) Term: **14 Years**

OTHER PUBLICATIONS

(21) Appl. No.: **29/484,039**

“Podium Imports ISM Saddles.” Podium Imports., Feb. 20, 2013
[online], [retrieved on Jul. 19, 2014]. Retrieved from the Internet
<URL: <http://www.podiumimports.ca/shop-online/brand/ism-saddles/>>.*

(22) Filed: **Mar. 5, 2014**

(51) **LOC (10) Cl.** **12-11**

(52) **U.S. Cl.**

USPC **D6/354**

(58) **Field of Classification Search**

CPC B62J 1/002; B62J 1/005; B62J 1/007;
B62J 1/26

USPC D6/340, 354; D12/110, 111; 296/65.13,
296/68.1, 132; 297/195.1, 196–215,
297/215.1–216.16, 452.1, 452.11–452.19,
297/452.21, 452.4, 452.55–452.59,
297/452.63–452.65

See application file for complete search history.

(Continued)

Primary Examiner — Philip S Hyder

Assistant Examiner — Darlington Ly

(74) *Attorney, Agent, or Firm* — Akerman LLP; Peter A.
Chiabotti

(57)

CLAIM

The ornamental design for a bicycle seat, as shown and
described.

DESCRIPTION

(56) **References Cited**

U.S. PATENT DOCUMENTS

642,191 A 1/1890 Wright
464,653 A 12/1891 Latta
532,444 A 1/1895 Christy
537,375 A 4/1895 Wright et al.
568,626 A 9/1896 Pierce et al.
570,497 A 11/1896 Pattison
572,062 A 11/1896 Peck
602,732 A 4/1898 Craig
605,151 A 6/1898 Twist
608,682 A 8/1898 Jamieson
612,552 A 10/1898 Standeford

FIG. 1 is a perspective view of the ornamental design;
FIG. 2 is a top plan view of the ornamental design of FIG. 1;
FIG. 3 is a bottom plan view of the ornamental design
FIG. 4 is a left side elevation view of the ornamental design of
FIG. 1;
FIG. 5 is a right side elevation view of the ornamental design
of FIG. 1;
FIG. 6 is a front elevation view of the ornamental design of
FIG. 1; and,
FIG. 7 is a rear elevation view of the ornamental design of
FIG. 1.

1 Claim, 5 Drawing Sheets

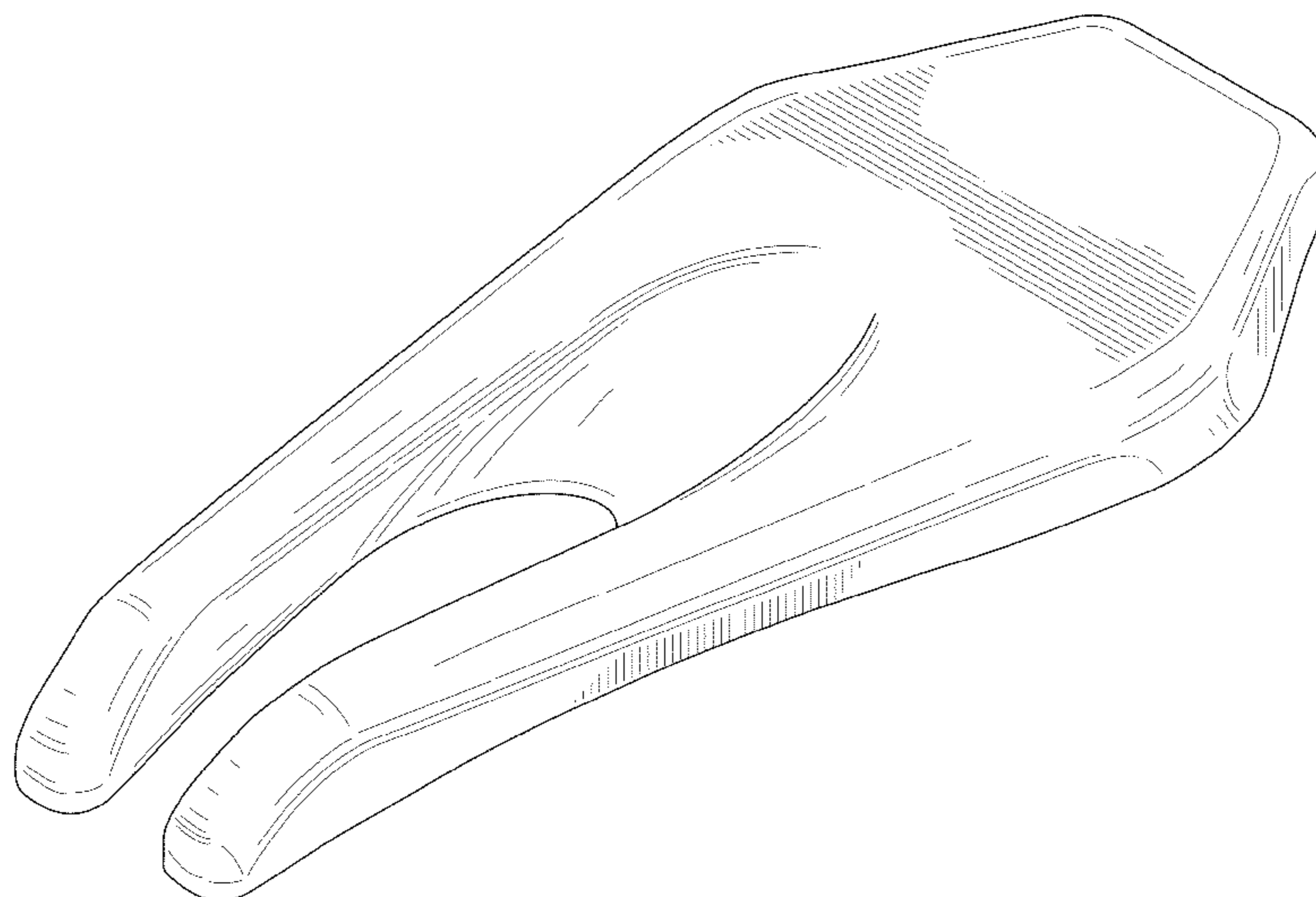

(56)

References Cited

U.S. PATENT DOCUMENTS

622,357 A 4/1899 Hitchcock et al.
 623,238 A 4/1899 Davis
 629,956 A 8/1899 Craig
 635,598 A 10/1899 Rowe
 654,720 A 7/1900 Engelbert
 701,390 A 6/1902 Provoost
 872,124 A 11/1907 Hammaren
 1,462,976 A 9/1922 Mesinger
 1,538,542 A 2/1924 Blake
 1,858,477 A 5/1932 Blake
 3,844,611 A 10/1974 Young
 4,429,915 A 2/1984 Flager
 4,898,422 A 2/1990 West
 4,999,068 A 3/1991 Chiarella
 5,011,222 A 4/1991 Yates et al.
 5,108,076 A 4/1992 Chiarella
 5,167,435 A 12/1992 Aldi
 5,676,420 A 10/1997 Kuipers et al.
 5,765,912 A 6/1998 Bontrager
 5,863,094 A 1/1999 Endo
 5,873,626 A 2/1999 Katz
 D407,910 S * 4/1999 Terry D6/354
 D408,159 S 4/1999 Clutton
 D409,009 S 5/1999 Toll et al.
 D416,394 S * 11/1999 Minkow et al. D6/354
 D417,560 S 12/1999 Tollefson et al.
 6,019,423 A 2/2000 Dodge et al.
 6,039,395 A 3/2000 Culbertson
 6,113,184 A 9/2000 Barnes
 6,193,309 B1 * 2/2001 Gootter et al. 297/202
 6,224,151 B1 5/2001 McMullen
 6,244,655 B1 * 6/2001 Minkow et al. 297/202
 D454,258 S * 3/2002 Yates D6/354
 6,422,647 B1 7/2002 Turudich
 6,450,572 B1 9/2002 Kuipers
 6,652,025 B2 11/2003 Sylvester
 6,783,176 B2 8/2004 Ladson, III
 6,957,857 B1 10/2005 Lee
 7,025,417 B2 4/2006 Cohen
 7,077,469 B2 7/2006 Farré
 7,104,600 B2 9/2006 Scholz
 7,121,622 B1 10/2006 Mendez
 D575,070 S 8/2008 Toll
 7,537,281 B2 5/2009 Riondato
 D604,056 S * 11/2009 Toll et al. D6/354
 D604,057 S * 11/2009 Toll D6/354
 7,699,391 B2 4/2010 Riondato
 D622,973 S * 9/2010 Toll D6/354
 7,934,770 B2 5/2011 Toll
 D639,081 S * 6/2011 Toll D6/354
 D677,479 S 3/2013 Toll
 D684,780 S 6/2013 Toll
 D684,781 S * 6/2013 Toll D6/354
 D688,051 S 8/2013 Toll
 D688,052 S 8/2013 Toll
 D688,477 S 8/2013 Toll
 D688,478 S 8/2013 Toll
 D688,479 S 8/2013 Toll
 2002/0117880 A1 8/2002 Ladson
 2003/0034678 A1 2/2003 Farré

2003/0067195 A1 4/2003 Sylvester
 2003/0071498 A1 4/2003 Yu
 2005/0006932 A1 1/2005 Laidlaw
 2007/0069557 A1 * 3/2007 Toll 297/202
 2007/0200399 A1 8/2007 Riondato
 2008/0265636 A1 * 10/2008 Toll 297/202
 2009/0079237 A1 3/2009 Riondato
 2011/0298253 A1 * 12/2011 Toll 297/214

FOREIGN PATENT DOCUMENTS

JP 2011143734 A * 7/2011 B62J 1/00
 JP 2012162255 A * 8/2012 B62J 1/00
 WO 99/14103 3/1999
 WO 2006015731 2/2006
 WO 2007/038692 4/2007
 WO 2014/035972 2/2011
 WO 2013/134253 9/2013

OTHER PUBLICATIONS

Demerly, Tom. "ISM Adamo Time Trial and Racing 2 Saddles: The Triathlon Saddle Evolved." Just Tri Talk., Feb. 27, 2013 [online], [retrieved on Jul. 19, 2014]. Retrieved from the Internet <URL: <http://justtritalk.com/ism-adamo-time-trial-and-racing-2-saddles-the-triathlon-saddle-evolved/>>.*
 Ilan Leibovitch, Yoram Mor, "The Vicious Cycling: Bicycling Related Urogenital Disorders", European Urology 47, pp. 277-287 (2005).
 Eddy Randrup, M.D., and Neil Baum, M.D., "Bicycle Riding as a Cause for Erectile Dysfunction", www.medicalsexuality.org, pp. 26-27, (Nov. 2000).
 S. J. Jeong, K. Park, J. D. Moon, and SB Ryu, "Bicycle Saddle Shape affects penile blood flow", International Journal of Impotence Research, 14, 513-517 (2002).
 Ian R. Spears, Neil K. Cummins, Zoe Brenchley, Claire Donahue, Carl! Turnbull, Shona Burton, and Gabrielle A. Macho, "The Effect of Saddle Design on Stresses in the Perineum during Cycling", Medical Science Sports Exercise, vol. 35, No. 9, pp. 1620-1625 (2003).
 Eadric Bressel, and Brad J. Larson, "Bicycle Seat Designs and Their Effect on Pelvic Angle, Trunk Angle, and Comfort", Medical Science Sports Exercise, vol. 35, No. 2, pp. 327-332 (2003).
 G. Breda, M.D., N. Piazza, M.D., V. Bernardi, M.D., E. Lundardon, M.D., and Adara Caruso, M.D., "Development of New Geometric Bicycle Saddle for the Maintenance of Genital—Perineal Vascular Perfusion," Journal of Sexual Medicine, vol. 2, Issue 5, pp. 605-611 (Sep. 2005).
 Brian D. Lowe, Steven M. Schrader, and Michael J. Breitenstein, "Effect of Bicycle Saddle Designs on the Pressure to the Perineum of the Bicyclist", Medical Science Sports Exercise, vol. 36, No. 6, pp. 1055-1062 (2004).
 Eadric Bressel, John Cronin, and Alicia Exeter, "Bicycle Seat Interface Pressure: Reliability, Validity, and Influence of Hand Position and Workload", Journal of Biomechanics, vol. 38, Issue 6, pp. 1325-1331 (Jun. 2005).
 Eadric Bressel, Tracey Reeve, Dan Parker, John Cronin, "Influence of Bicycle Seat Pressure on compression of the perineum: a MRI Analysis," Journal of Biomechanics 40, pp. 198-202 (2007, Accepted Nov. 26, 2005).

* cited by examiner

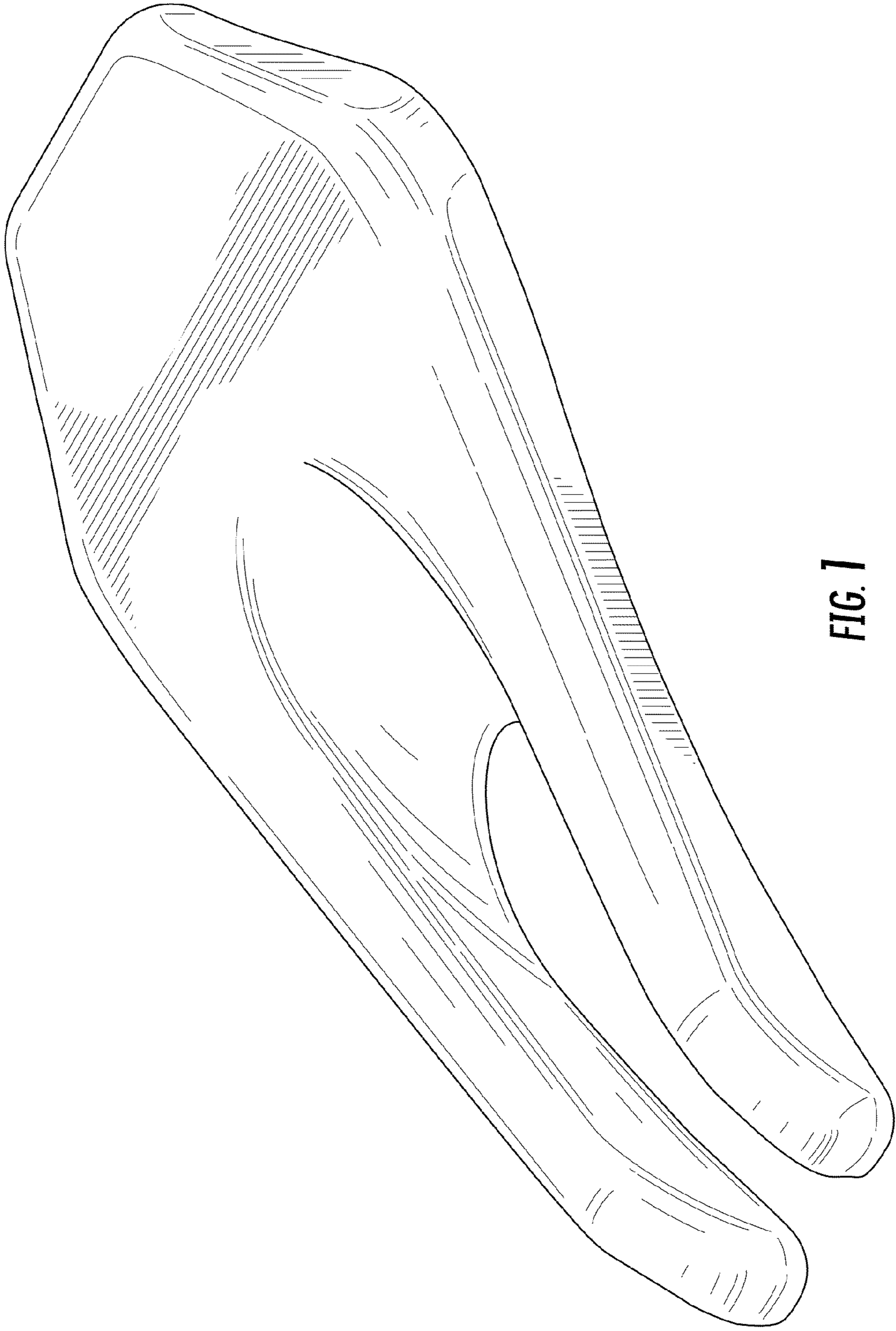

FIG. 1

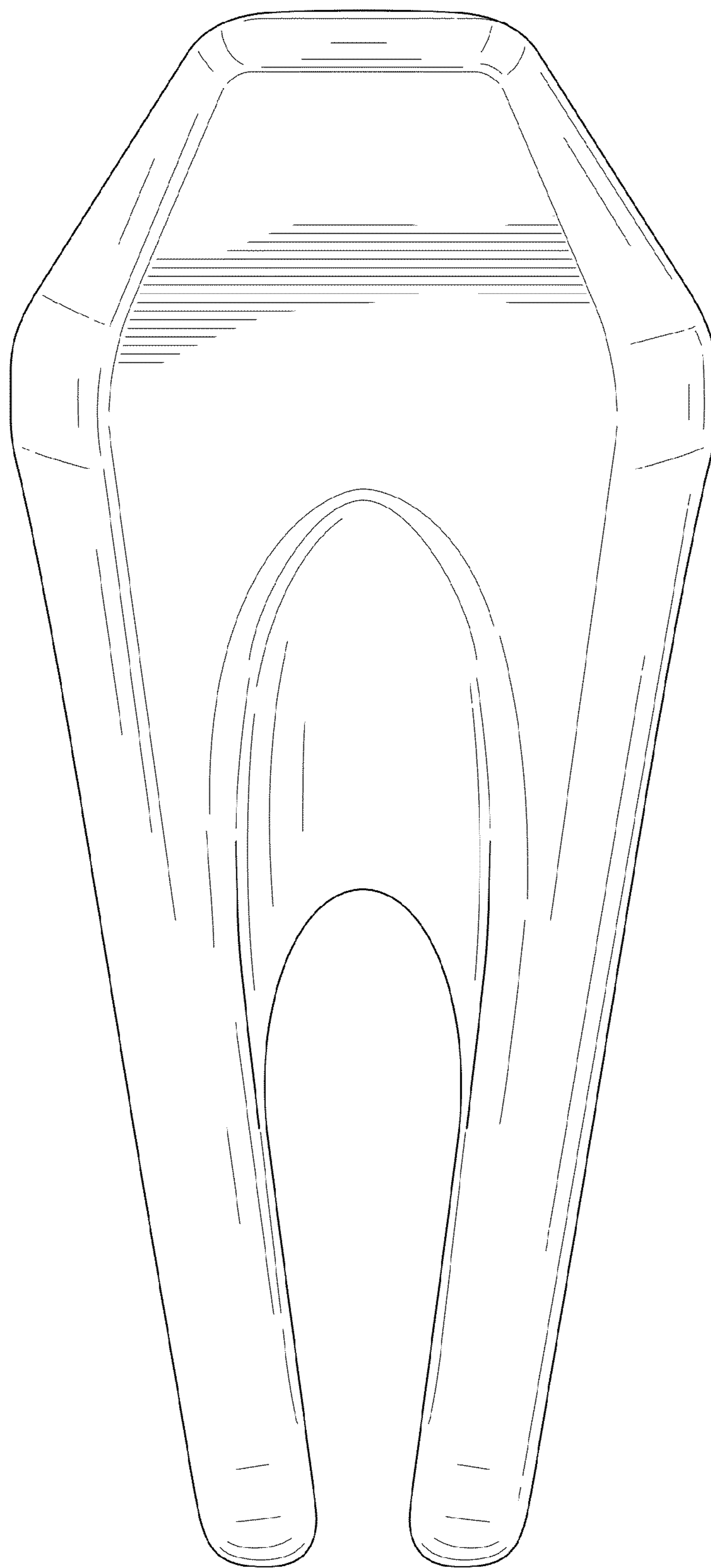

FIG. 2

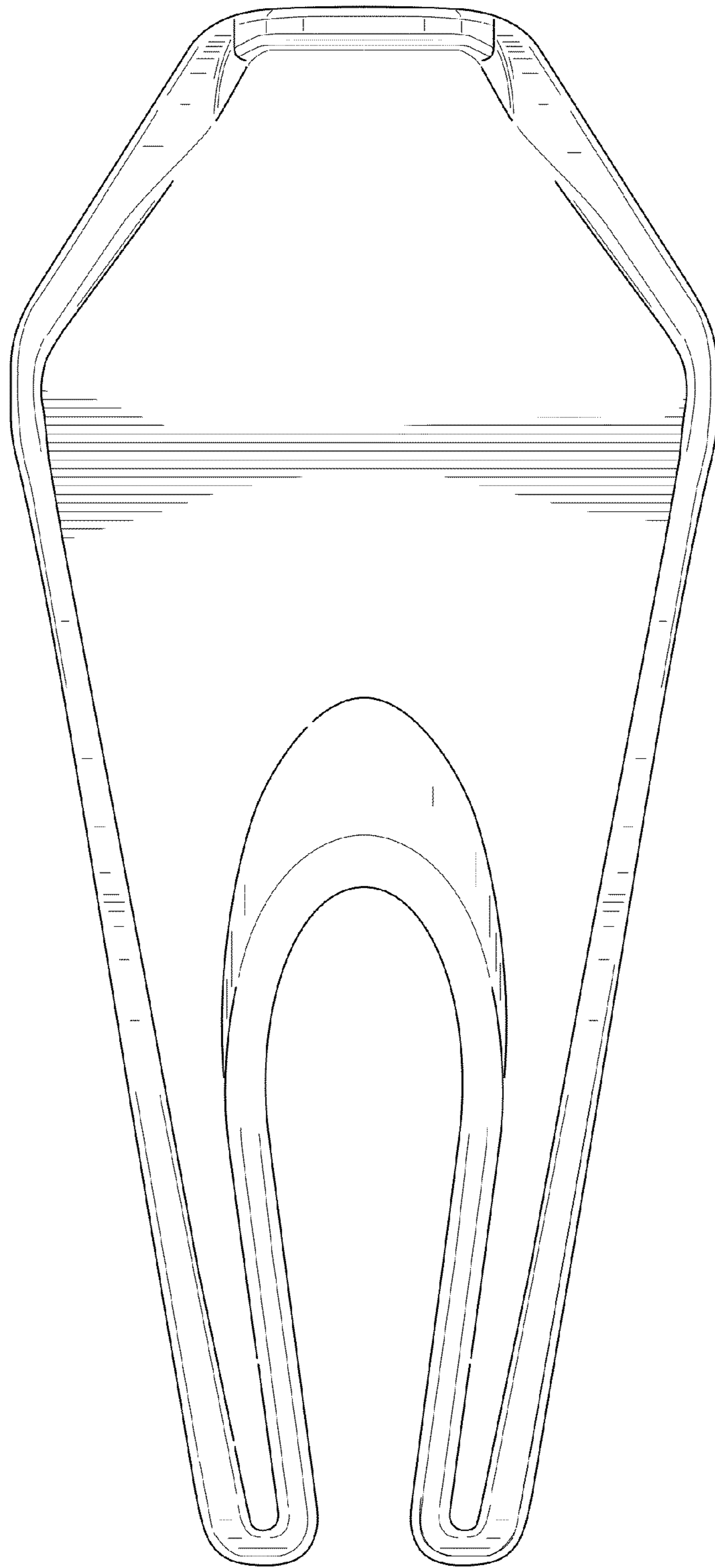

FIG. 3

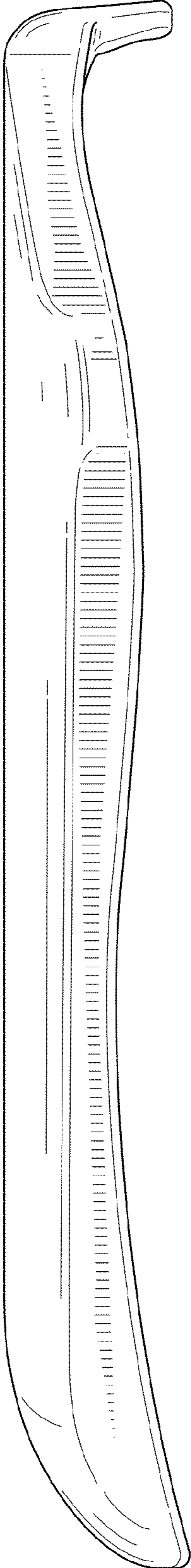

FIG. 4

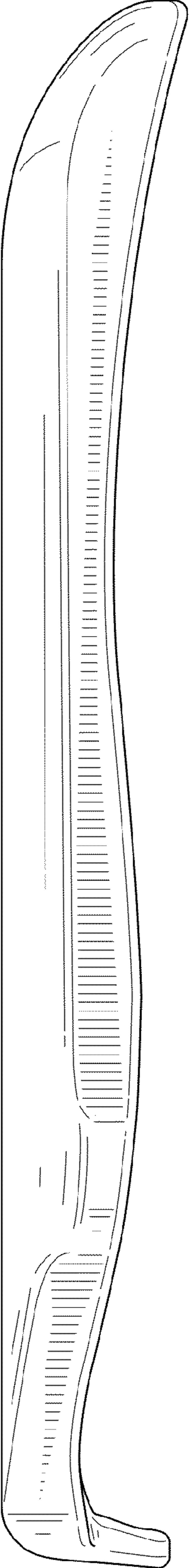

FIG. 5

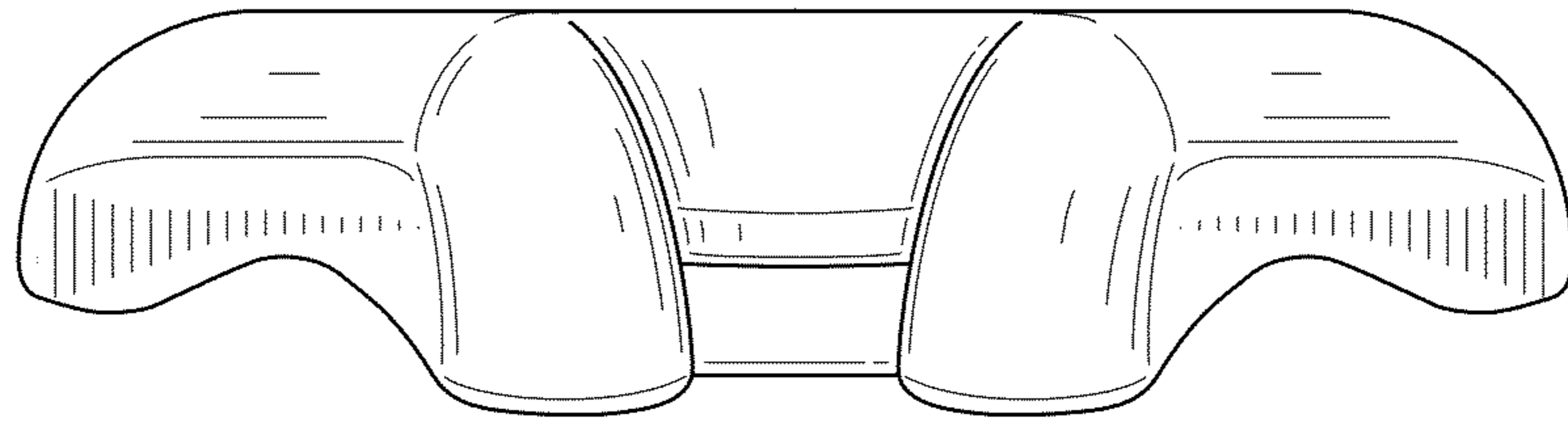

FIG. 6

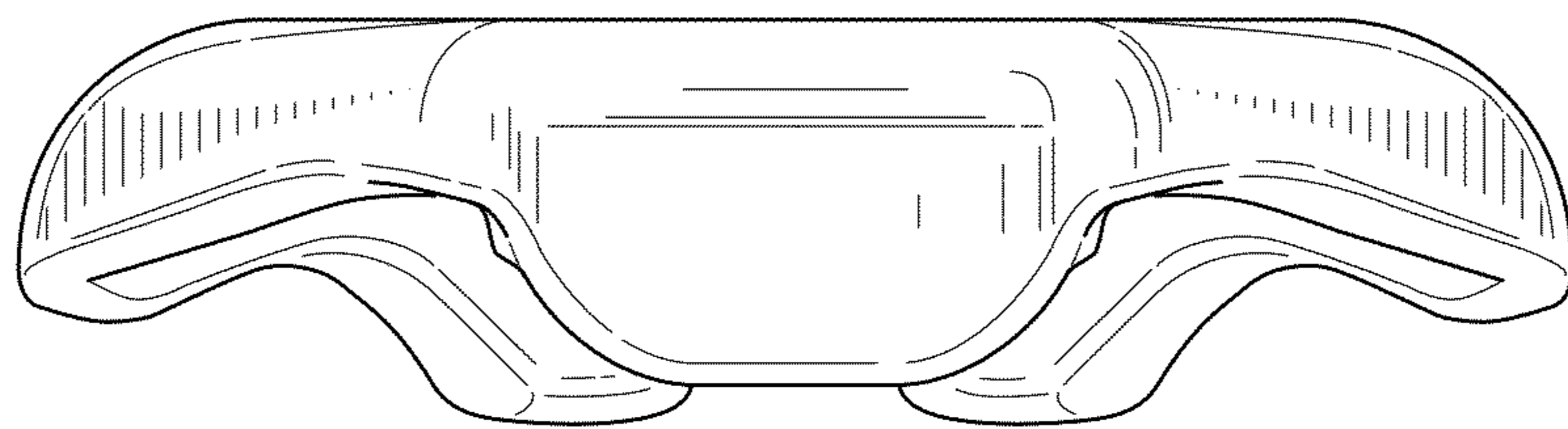

FIG. 7