



US00D723741S

(12) **United States Design Patent**  
**Caplan**

(10) **Patent No.:** **US D723,741 S**  
(45) **Date of Patent:** **\*\* Mar. 3, 2015**

- (54) **HAIR EXTENSION HOLDER**
- (71) Applicant: **Emily J. Caplan**, Savage, MN (US)
- (72) Inventor: **Emily J. Caplan**, Savage, MN (US)
- (\*\*) Term: **14 Years**
- (21) Appl. No.: **29/433,044**
- (22) Filed: **Sep. 25, 2012**
- (51) **LOC (10) Cl.** ..... **28-03**
- (52) **U.S. Cl.**  
USPC ..... **D28/73; D6/514; D6/553**
- (58) **Field of Classification Search**  
USPC ..... D28/9, 10, 73; 206/6.1, 495, 457, 288,  
206/289, 464; D6/553, 512, 514, 315;  
D3/293, 303  
See application file for complete search history.

D659,905	S	*	5/2012	Fingerson	.....	D28/73
D659,906	S	*	5/2012	Whitman	.....	D28/73
D666,440	S	*	9/2012	Kinskey et al.	.....	D6/514
D685,590	S	*	7/2013	Hale et al.	.....	D6/514
2004/0222125	A1	*	11/2004	Meing	.....	206/581
2006/0065280	A1		3/2006	Cheung		
2009/0008347	A1		1/2009	Bell		
2010/0155266	A1	*	6/2010	Nicholson	.....	206/6.1
2011/0132942	A1		6/2011	Choi		
2011/0284397	A1		11/2011	Batres et al.		
2012/0006696	A1		1/2012	Choi		

\* cited by examiner

*Primary Examiner* — Jennifer Rivard  
(74) *Attorney, Agent, or Firm* — Meister Seelig & Fein LLP

(57) **CLAIM**  
The ornamental design for hair extension holder, as shown and described.

**DESCRIPTION**

FIG. 1 is a perspective view of the hair extension holder according to my new design;  
 FIG. 2 is a front view thereof;  
 FIG. 3 is a back view thereof;  
 FIG. 4 is a left side view thereof;  
 FIG. 5 is a right side view thereof;  
 FIG. 6 is a top view thereof; and,  
 FIG. 7 is a bottom view thereof.

The dot-dash lines on the surface of the hair extension holder represent stitching.  
 The stitching shown in dot-dash lines is part of the claimed design.  
 The dashed lines, which are of equal length in the drawings, illustrate the environment of the hair extension holder and form no part of the claimed design.

**1 Claim, 5 Drawing Sheets**

- (56) **References Cited**  
U.S. PATENT DOCUMENTS
- |           |    |   |         |               |       |         |
|-----------|----|---|---------|---------------|-------|---------|
| 4,401,219 | A  | * | 8/1983  | Mink          | ..... | 206/566 |
| D321,789  | S  | * | 11/1991 | Martorella    | ..... | D3/293  |
| D332,697  | S  | * | 1/1993  | Schildkraut   | ..... | D3/303  |
| 5,427,230 | A  | * | 6/1995  | Mattox        | ..... | 206/6.1 |
| D369,261  | S  | * | 4/1996  | Brink         | ..... | D6/514  |
| D401,092  | S  | * | 11/1998 | Patel         | ..... | D6/525  |
| 6,631,527 | B2 |   | 10/2003 | Hyduk         |       |         |
| D543,760  | S  | * | 6/2007  | Utzinger, III | ..... | D6/553  |
| D544,274  | S  | * | 6/2007  | Hume          | ..... | D6/553  |
| 7,389,868 | B2 | * | 6/2008  | Lewand et al. | ..... | 206/6.1 |
| D605,441  | S  | * | 12/2009 | Lamplugh      | ..... | D6/514  |
| D622,448  | S  | * | 8/2010  | Whitman       | ..... | D28/73  |
| D625,128  | S  | * | 10/2010 | Ciauri-Sasner | ..... | D6/514  |
| D627,167  | S  | * | 11/2010 | Kittrell      | ..... | D3/299  |
| D643,154  | S  | * | 8/2011  | Dumala        | ..... | D28/75  |
| D644,426  | S  |   | 9/2011  | Skaggs        |       |         |

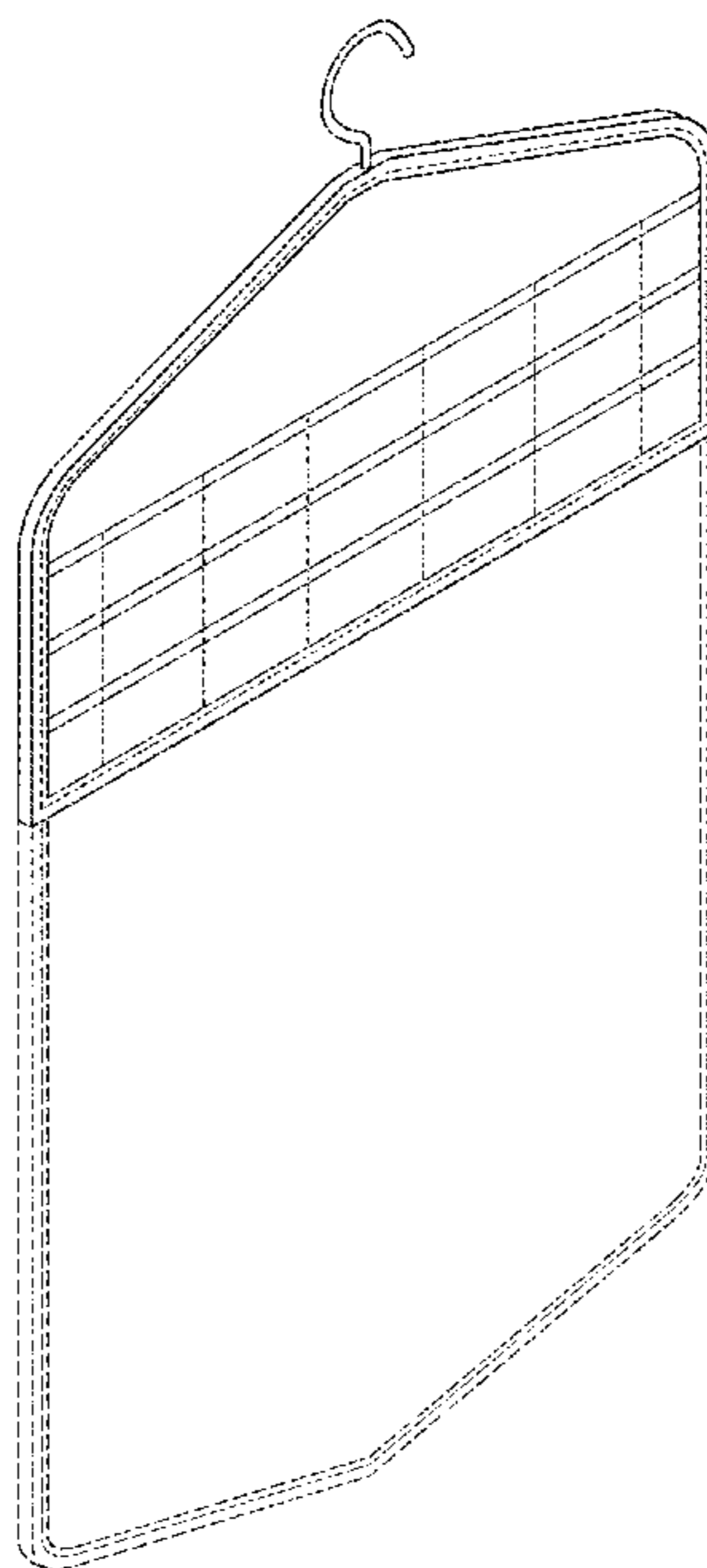

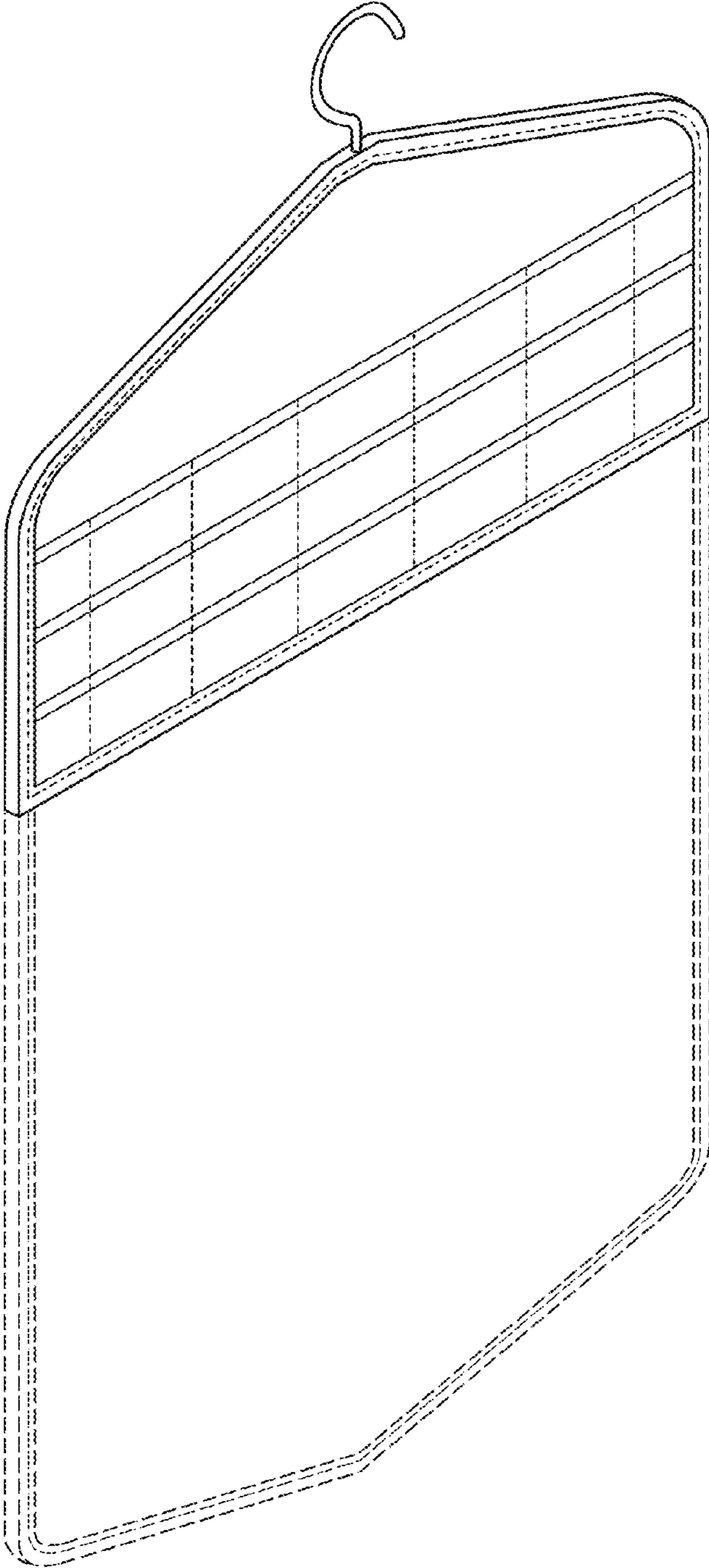

FIG. 1

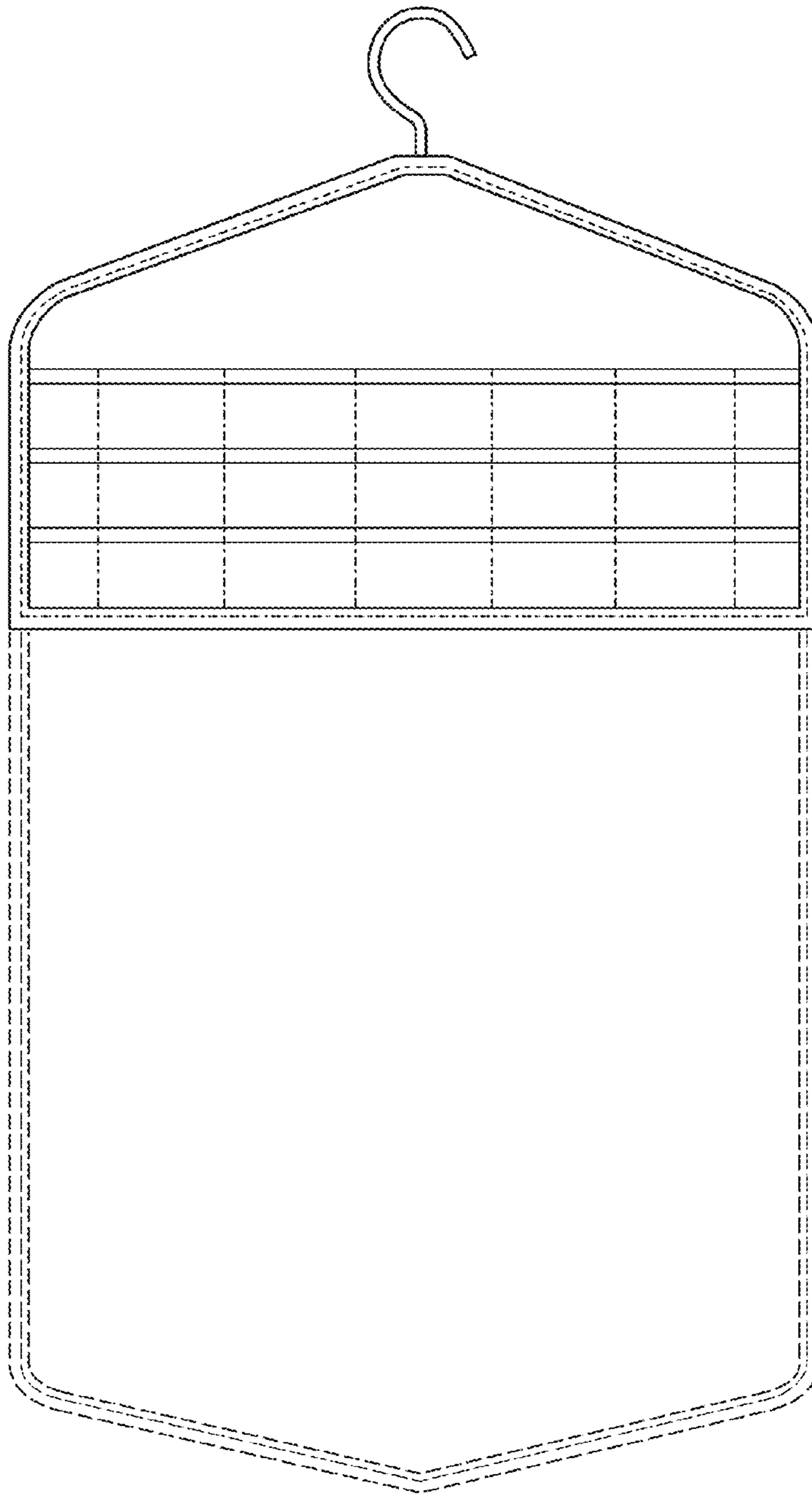

FIG. 2

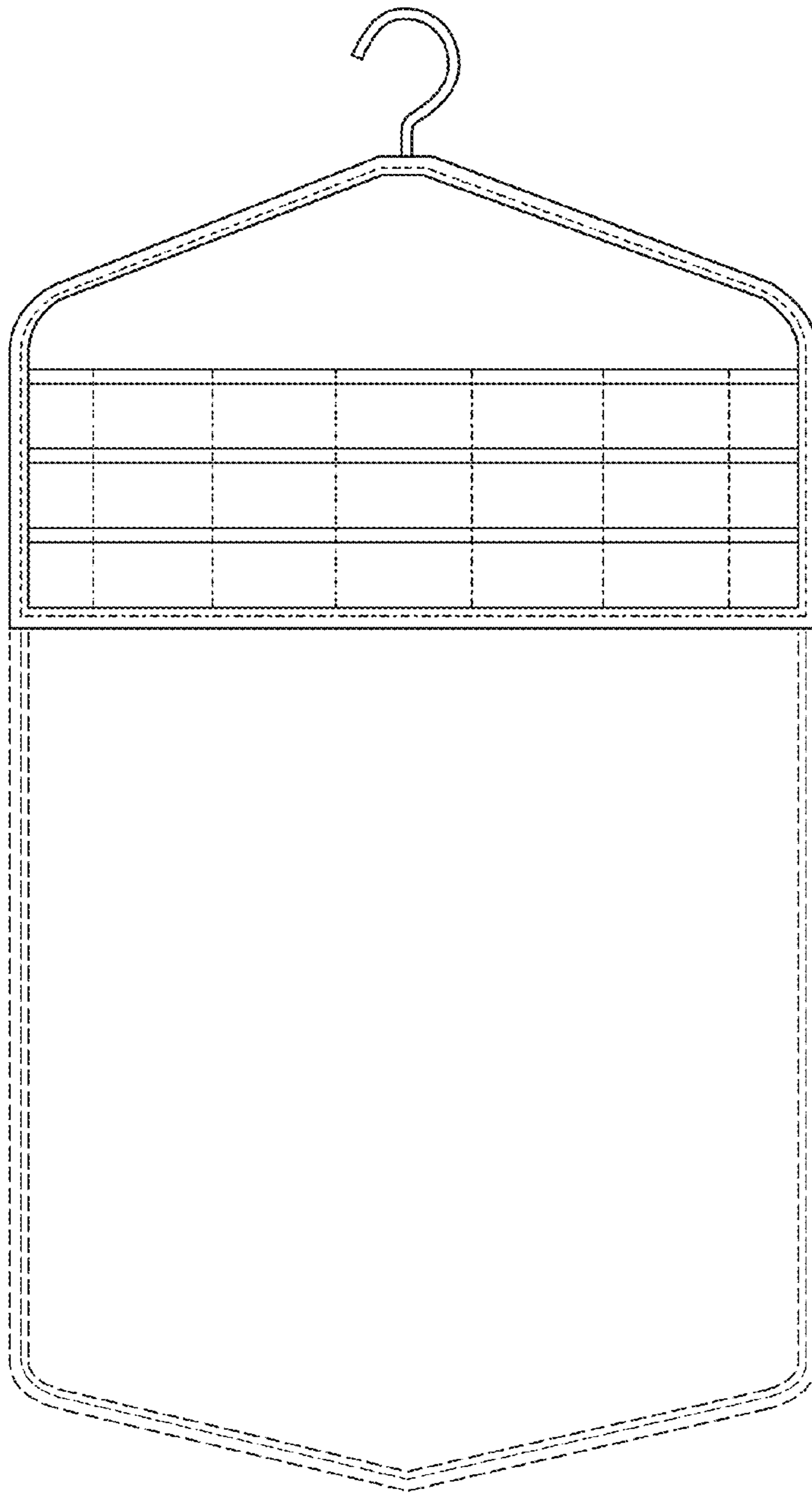

FIG. 3

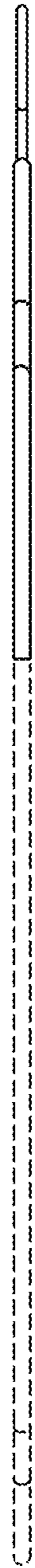

FIG. 4

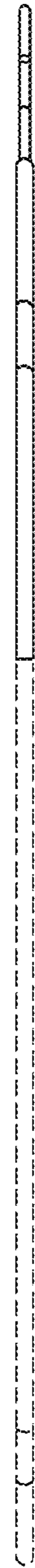
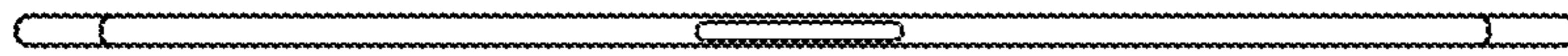

FIG. 5



**FIG. 6**



**FIG. 7**