



US00D723448S

(12) **United States Design Patent**
Woo et al.

(10) **Patent No.:** **US D723,448 S**
(45) **Date of Patent:** **** Mar. 3, 2015**

(54) **IN-VEHICLE INFOTAINMENT DEVICE**

(71) Applicants: **Sang-Sung Woo**, Seoul (KR); **Sang-Min Hyun**, Seoul (KR); **Dae-Joung Kim**, Seoul (KR)

(72) Inventors: **Sang-Sung Woo**, Seoul (KR); **Sang-Min Hyun**, Seoul (KR); **Dae-Joung Kim**, Seoul (KR)

(73) Assignee: **Samsung Electronics Co., Ltd.**, Suwon-si, Gyeonggi-do (KR)

(**) Term: **14 Years**

(21) Appl. No.: **29/450,633**

(22) Filed: **Mar. 20, 2013**

(30) **Foreign Application Priority Data**

Nov. 6, 2012 (KR) 30-2012-0052895

(51) **LOC (10) Cl.** **12-16**

(52) **U.S. Cl.**
USPC **D12/400**

(58) **Field of Classification Search**
USPC D12/400, 192, 415, 110, 114; 180/90;
280/750-752; 296/190.01-190.09,
296/191, 70; D15/17, 28; D10/46, 98,
D10/102-103, 122-127
See application file for complete search history.

(56) **References Cited**

U.S. PATENT DOCUMENTS

D242,313	S	*	11/1976	Stentz	D6/574
D648,339	S	*	11/2011	O'Neil et al.	D14/434
D651,952	S	*	1/2012	Pegorier et al.	D12/192
D682,840	S	*	5/2013	Tsai et al.	D14/447
D696,996	S	*	1/2014	Kim et al.	D12/192
D697,851	S	*	1/2014	Woo et al.	D12/192
D697,862	S	*	1/2014	Nemeth et al.	D12/345
D704,611	S	*	5/2014	Tilscher	D12/192

* cited by examiner

Primary Examiner — Katrina A Betton

(74) *Attorney, Agent, or Firm* — Flynn, Thiel, Boutell & Tanis, P.C.

(57) **CLAIM**

The ornamental design for an in-vehicle infotainment device, as shown and described.

DESCRIPTION

FIG. 1 is a top front perspective view of an in-vehicle infotainment device showing our new design; FIG. 2 is a front elevational view thereof; FIG. 3 is a rear elevational view thereof; FIG. 4 is a left side elevational view thereof; FIG. 5 is a right side elevational view thereof; FIG. 6 is a top plan view thereof; FIG. 7 is a bottom plan view thereof; and, FIG. 8 is a perspective view thereof showing the present in-vehicle infotainment device installed in a vehicle. The broken lines depict environmental subject matter only and form no part of the claimed design.

1 Claim, 5 Drawing Sheets

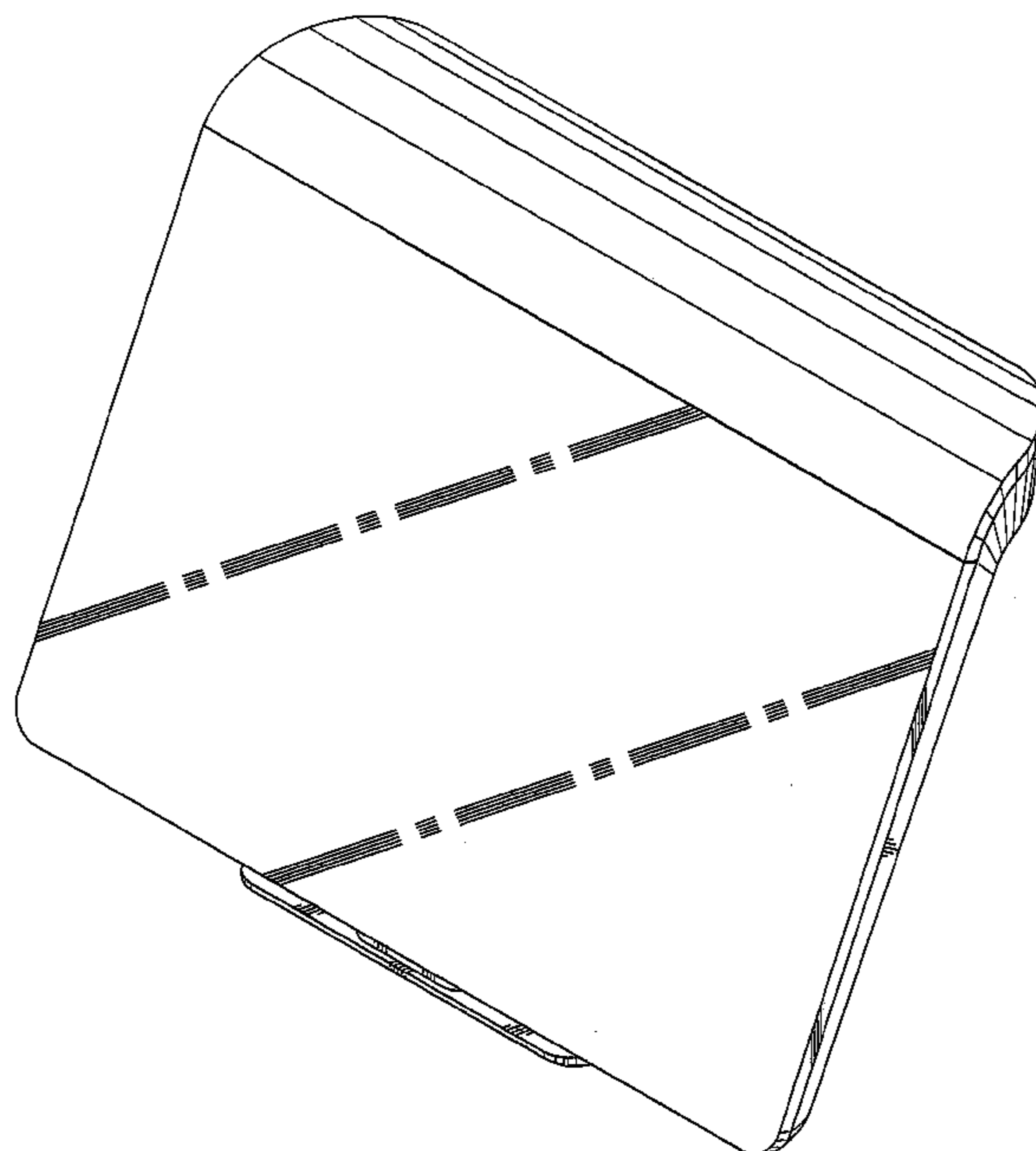

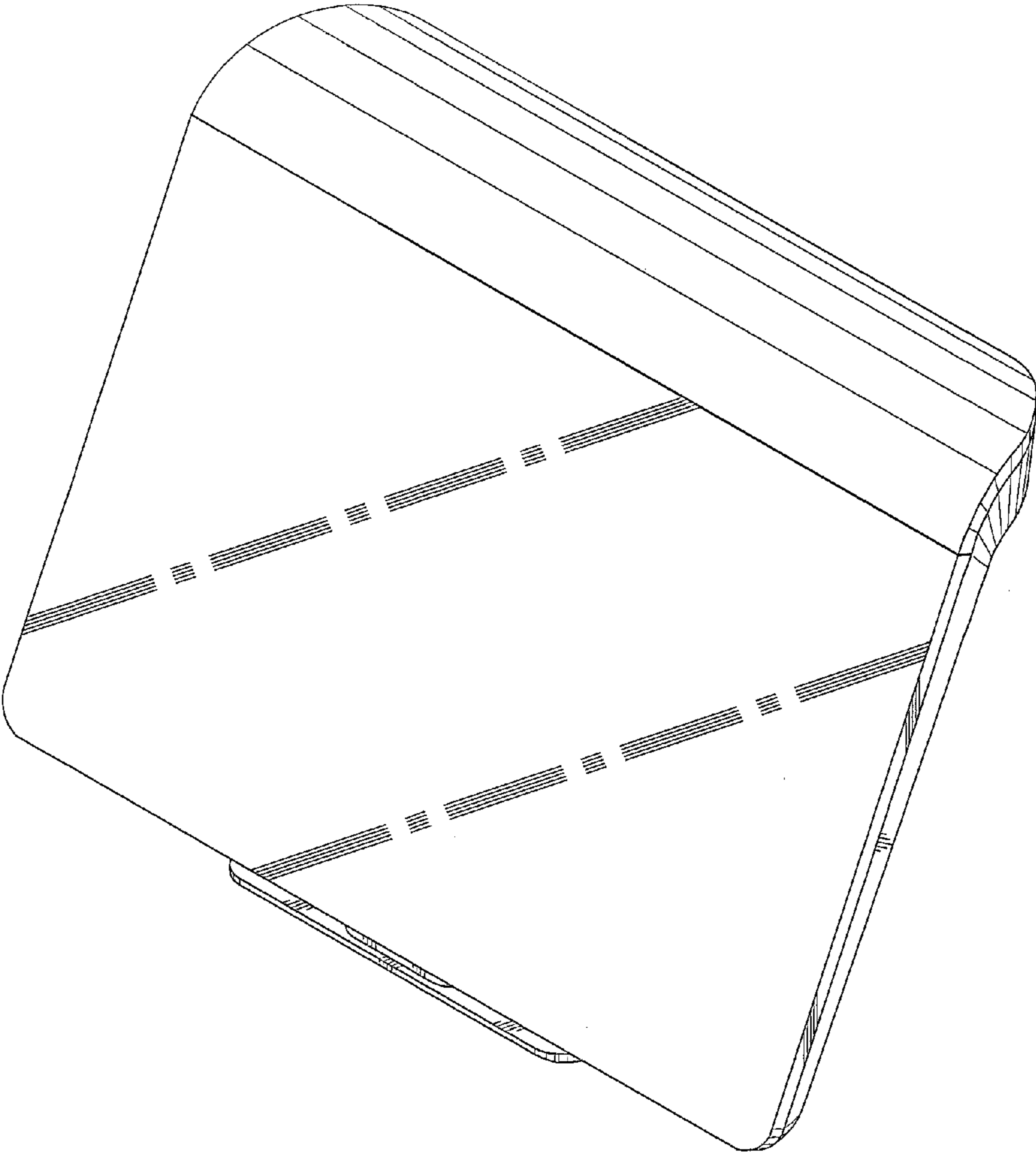

FIG.1

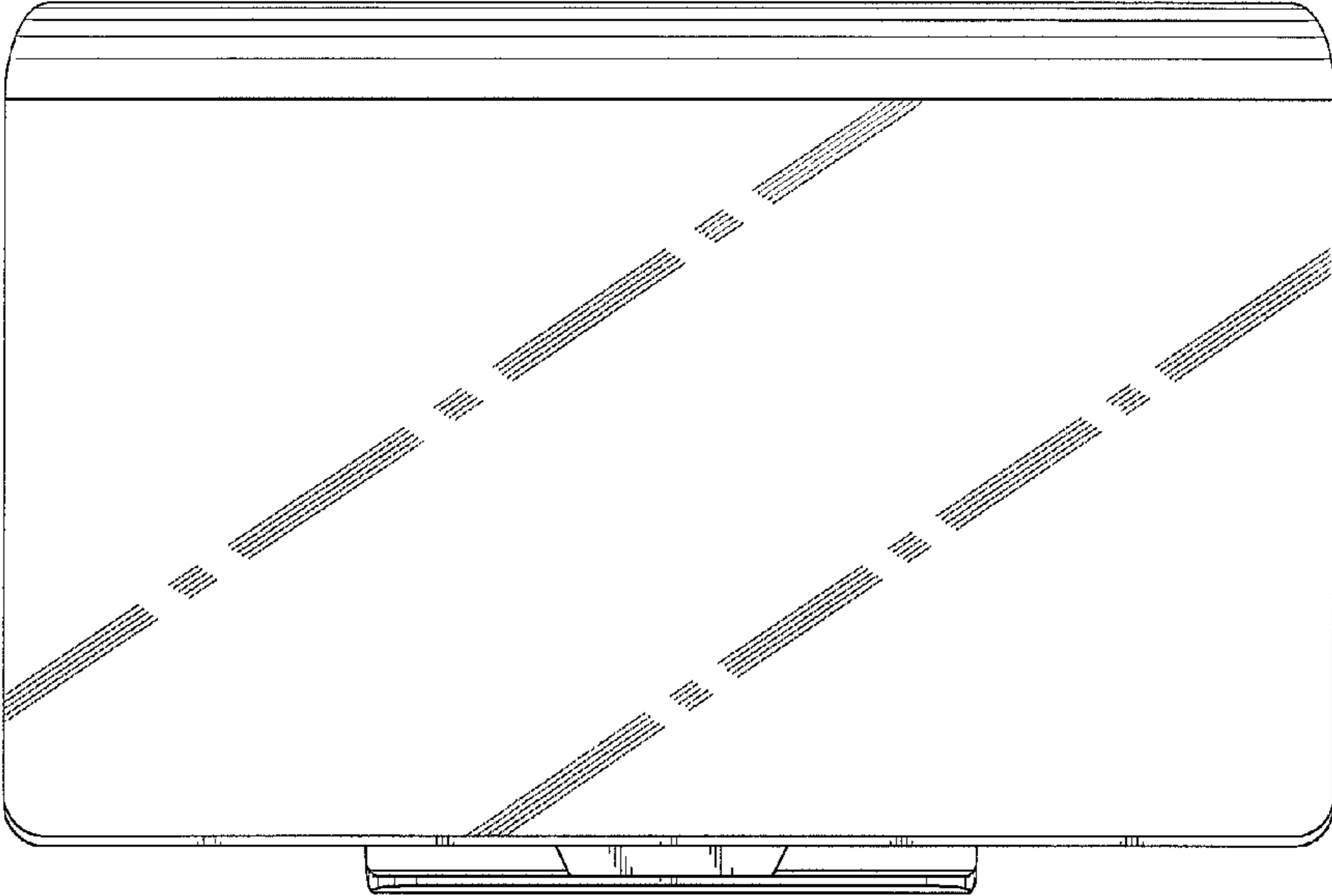

FIG. 2

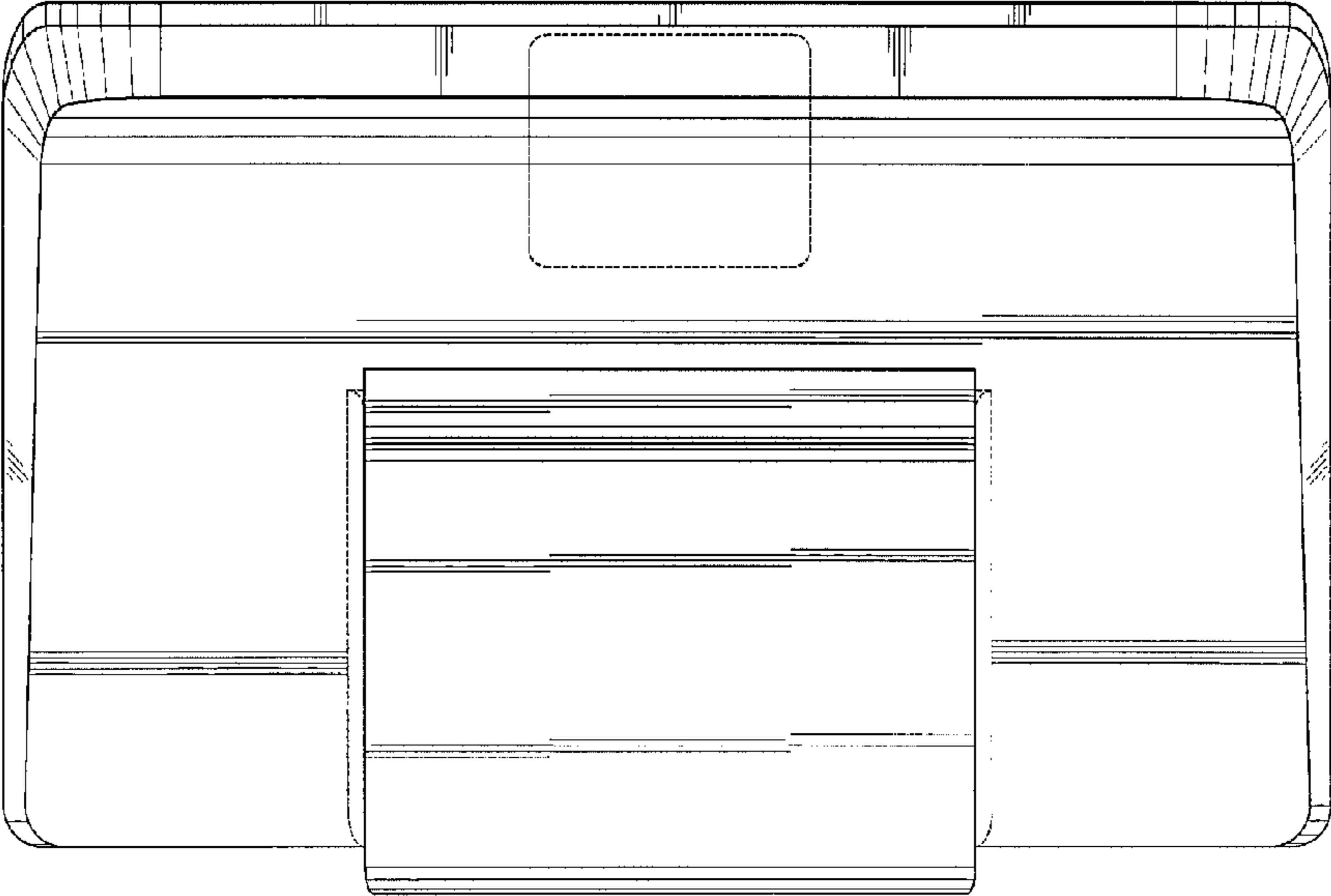

FIG. 3

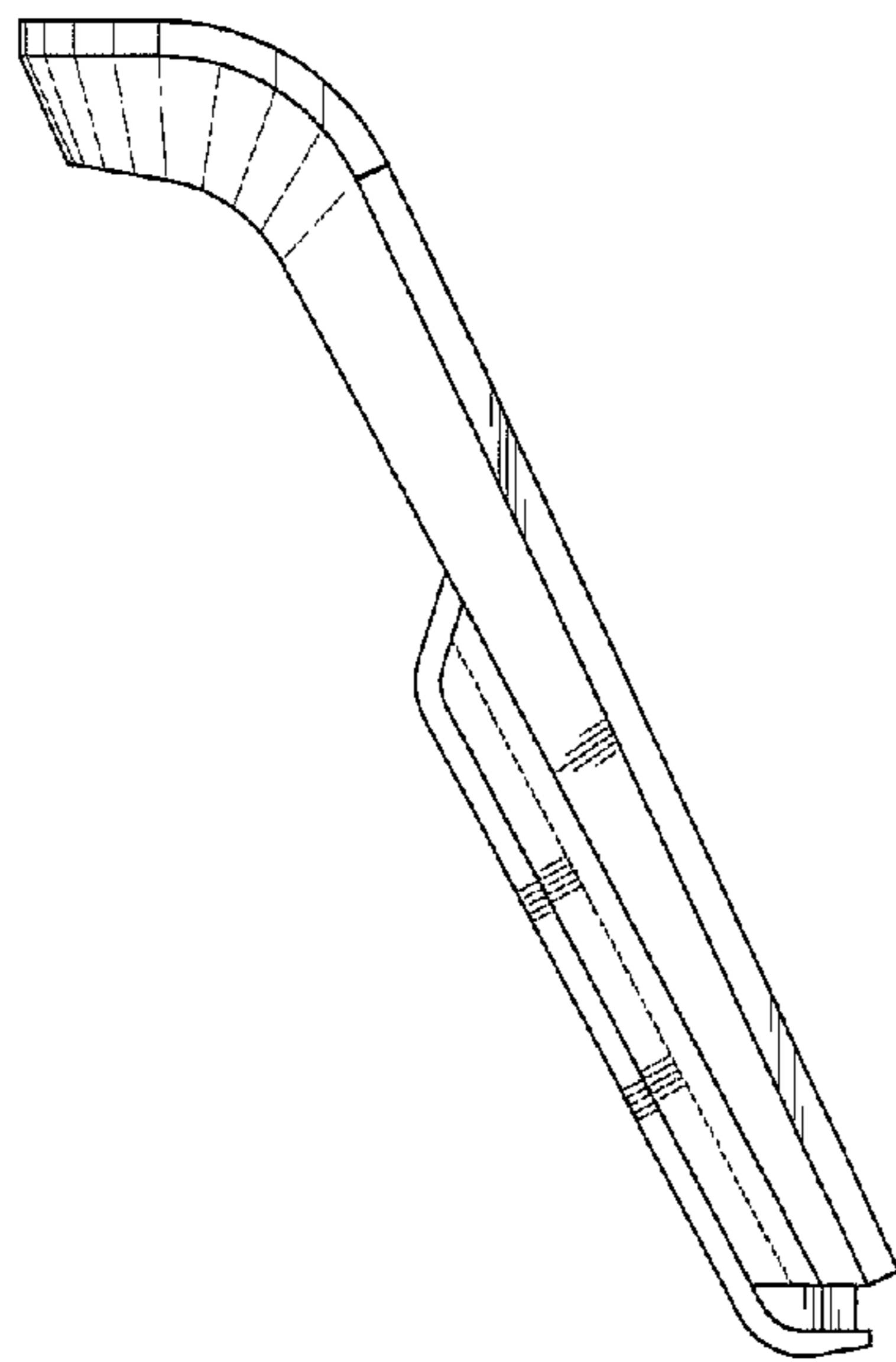

FIG. 4

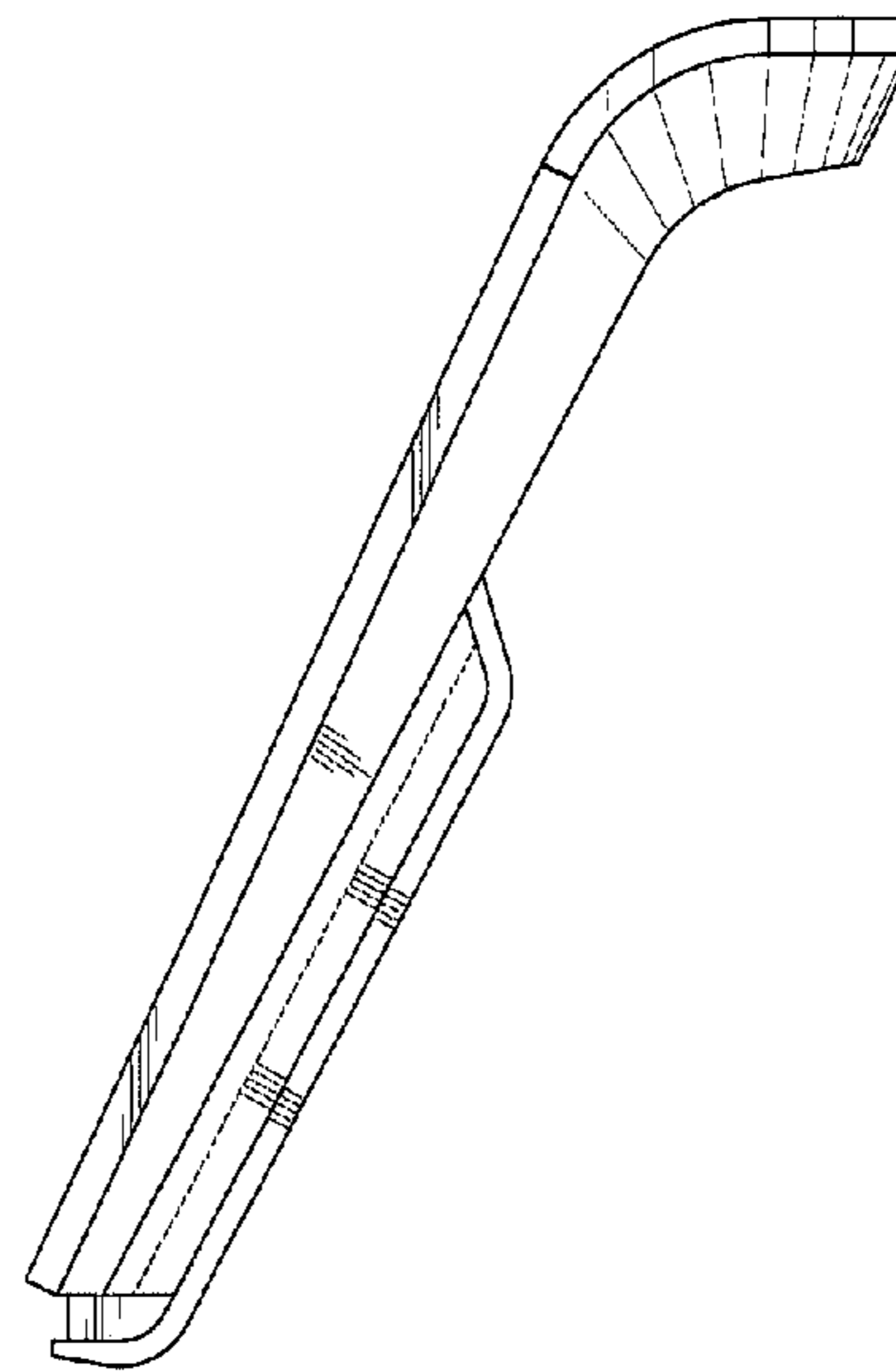

FIG. 5

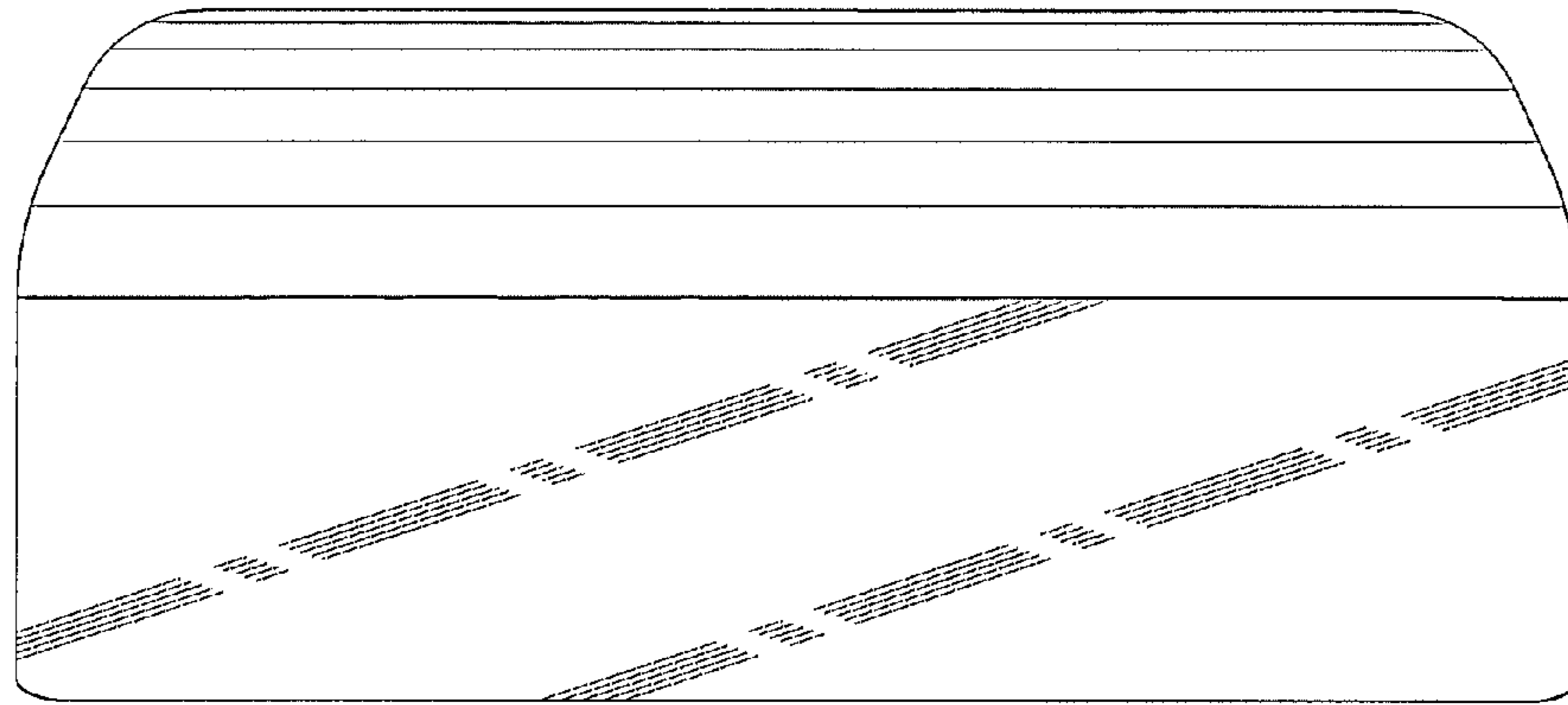

FIG. 6

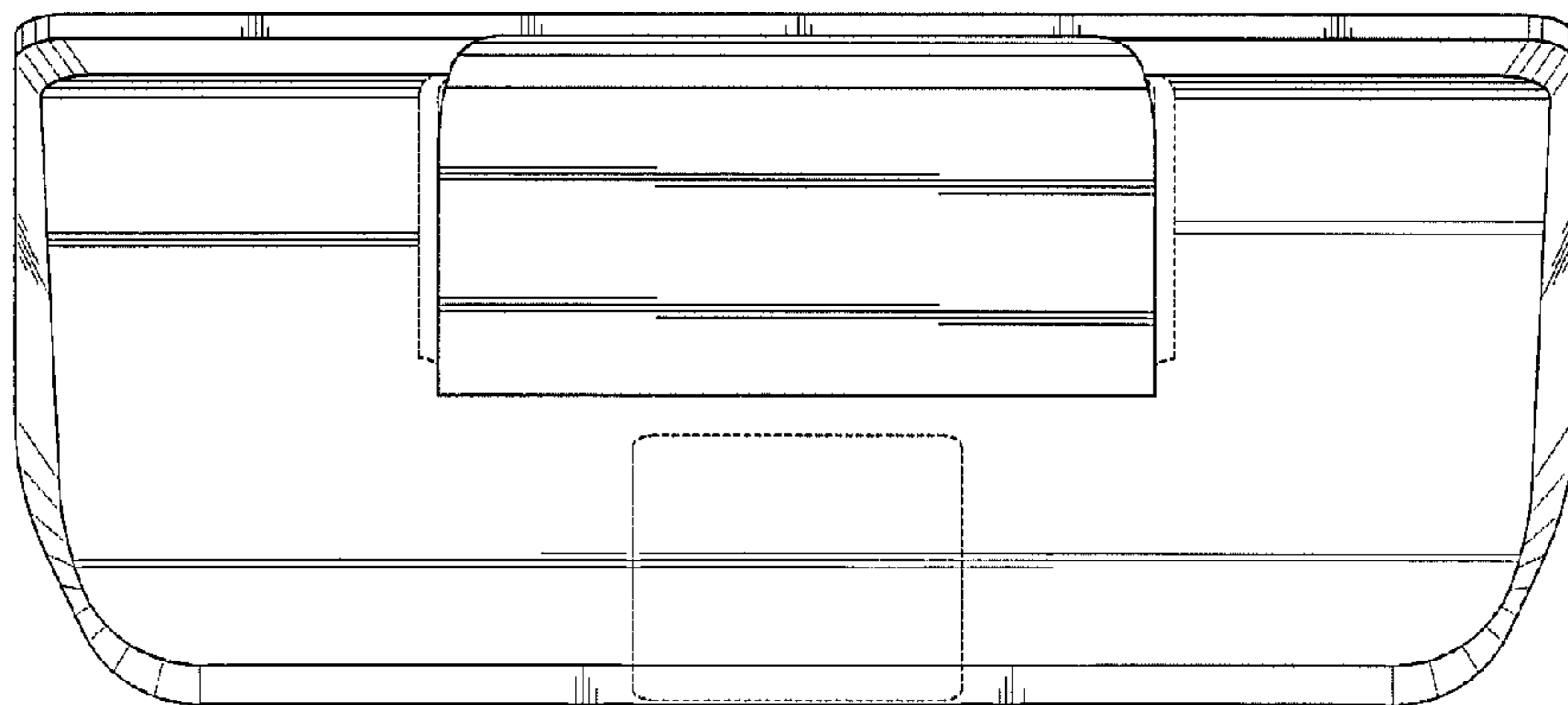

FIG. 7

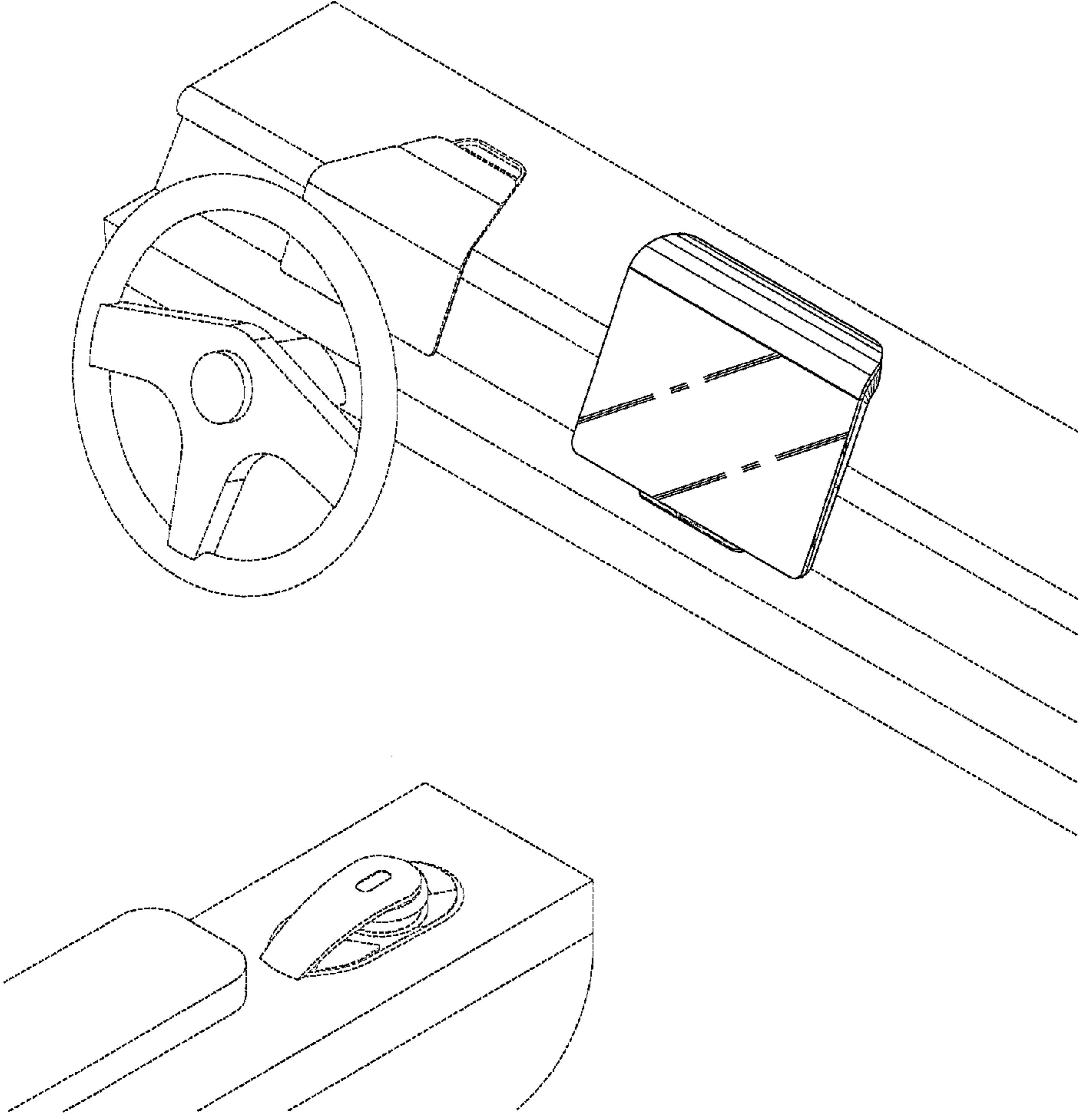

FIG.8