



US00D723343S

(12) **United States Design Patent**
Anzalone

(10) **Patent No.:** **US D723,343 S**

(45) **Date of Patent:** **** *Mar. 3, 2015**

(54) **GARLIC PRESS**

(71) Applicant: **Christopher Anzalone**, Foothill Ranch,
CA (US)

(72) Inventor: **Christopher Anzalone**, Foothill Ranch,
CA (US)

(73) Assignee: **Urban Trend, LLC**, Newport Beach,
CA (US)

(*) Notice: This patent is subject to a terminal dis-
claimer.

(**) Term: **14 Years**

(21) Appl. No.: **29/442,455**

(22) Filed: **Mar. 5, 2013**

(51) **LOC (10) Cl.** **07-04**

(52) **U.S. Cl.**
USPC **D7/666**

(58) **Field of Classification Search**
USPC D7/665, 666, 368, 669, 680, 683, 686,
D7/693, 388; 99/495, 505-510; 100/111,
100/125, 234; 241/84.3

See application file for complete search history.

(56) **References Cited**

U.S. PATENT DOCUMENTS

D420,863 S *	2/2000	Egana et al.	D7/666
D428,778 S *	8/2000	Kao	D7/666
6,318,252 B1 *	11/2001	Kao	100/125
D459,159 S *	6/2002	Kao	D7/666
D496,228 S *	9/2004	Greiner	D7/666

* cited by examiner

Primary Examiner — Terry Wallace

(57) **CLAIM**

The ornamental design for a garlic press, as shown and described.

DESCRIPTION

FIG. 1 is a front view of a garlic press of my new design;
FIG. 2 is a back view of FIG. 1;
FIG. 3 is a side view of FIG. 1;
FIG. 4 is a side view of a garlic press of my new design with the lever extended;
FIG. 5 is a top view of FIG. 1;
FIG. 6 is a bottom view of FIG. 1;
FIG. 7 is top and side perspective view of FIG. 1; and,
FIG. 8 is a top and side perspective view of a garlic press of my new design with the lever extended, the basket removed and the base separated.

1 Claim, 5 Drawing Sheets

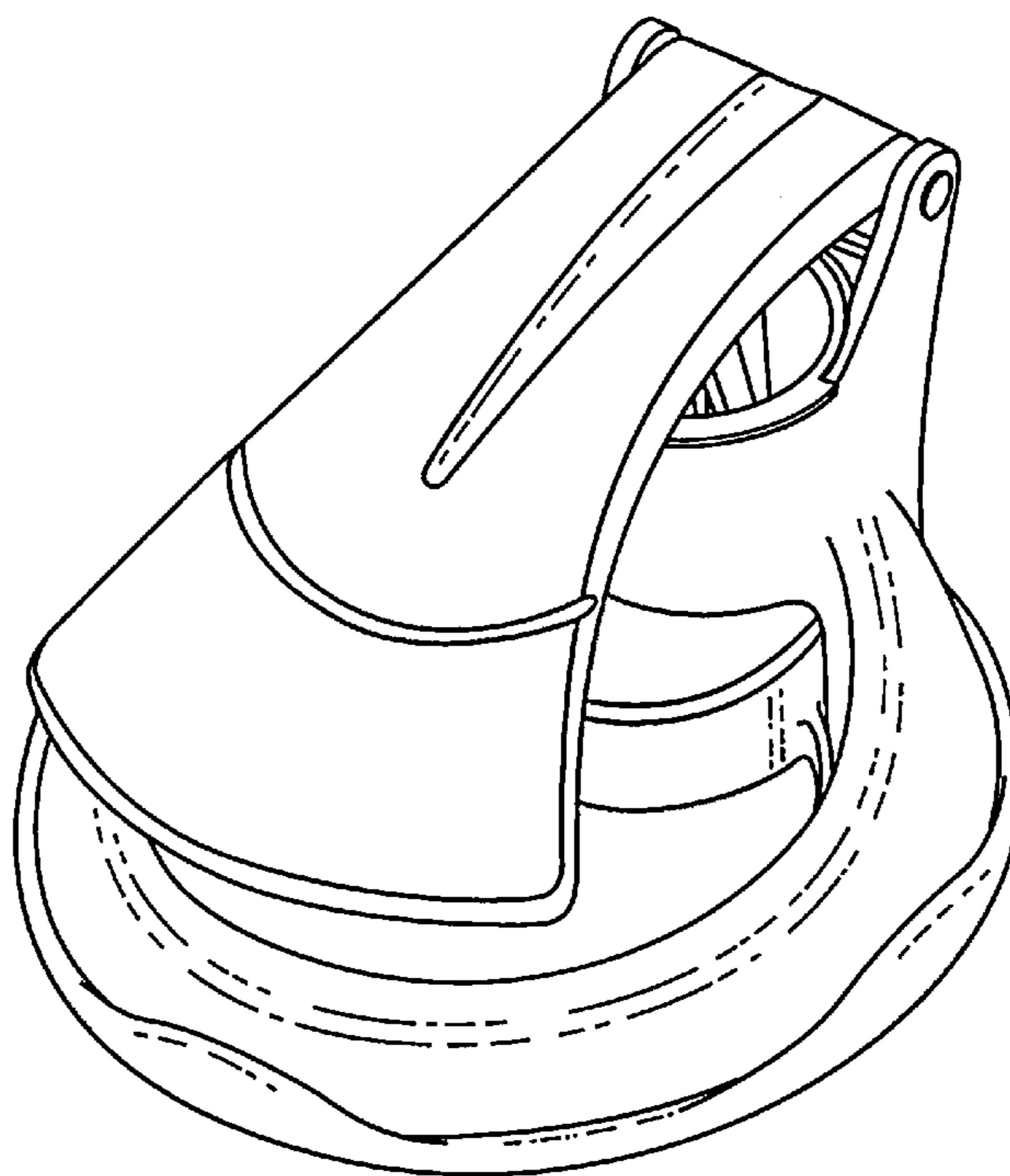

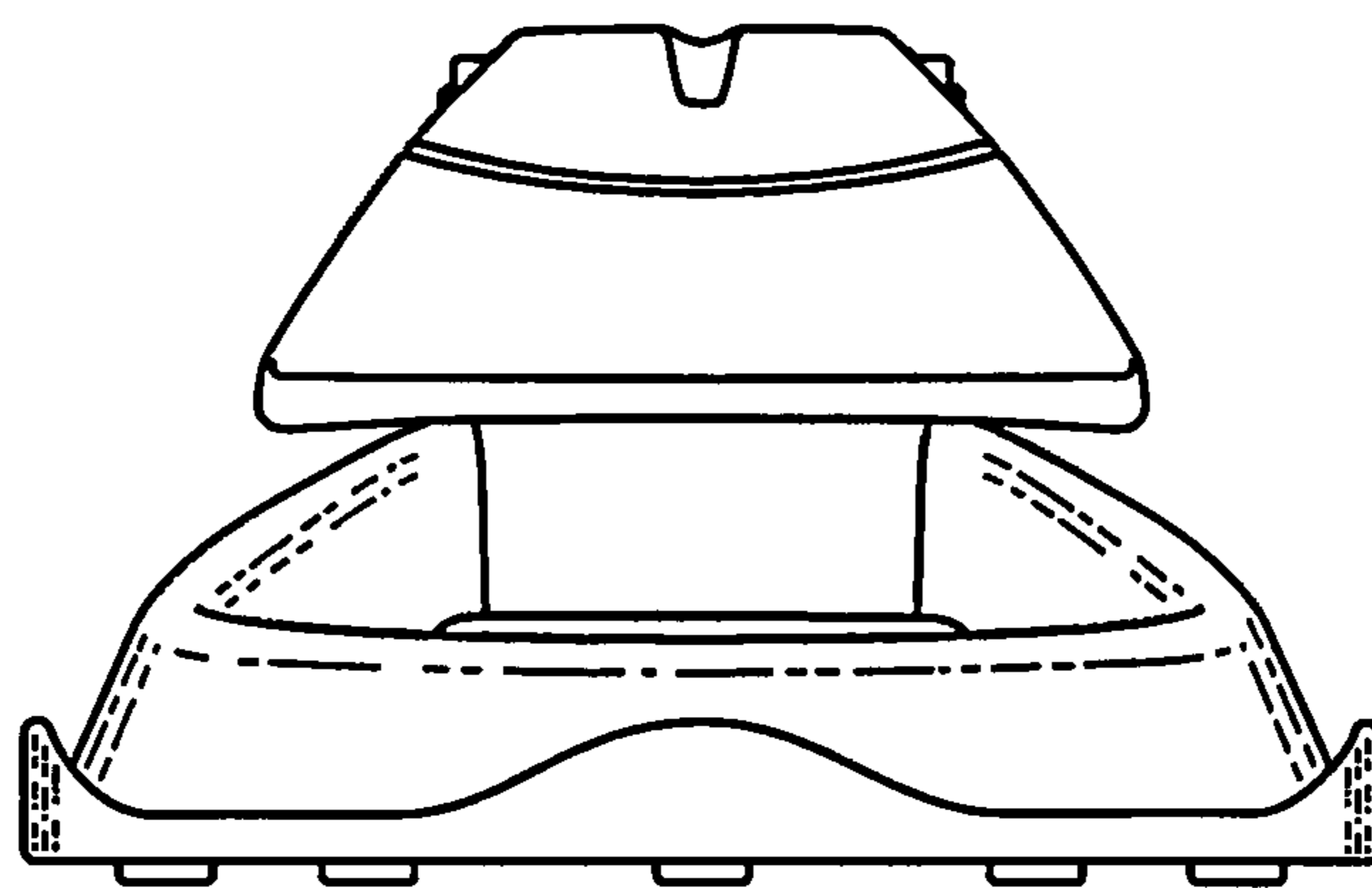

Fig. 1

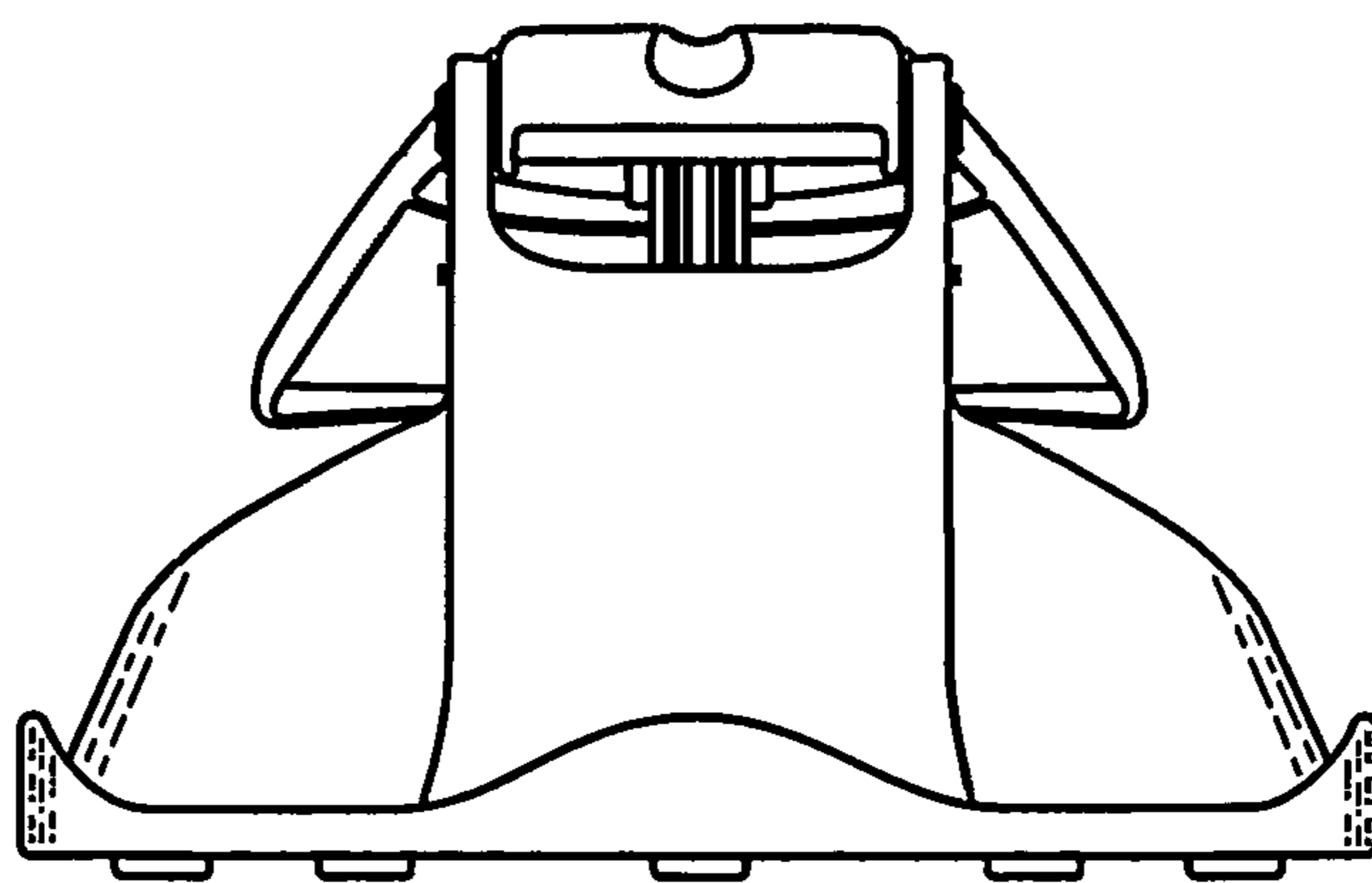

Fig. 2

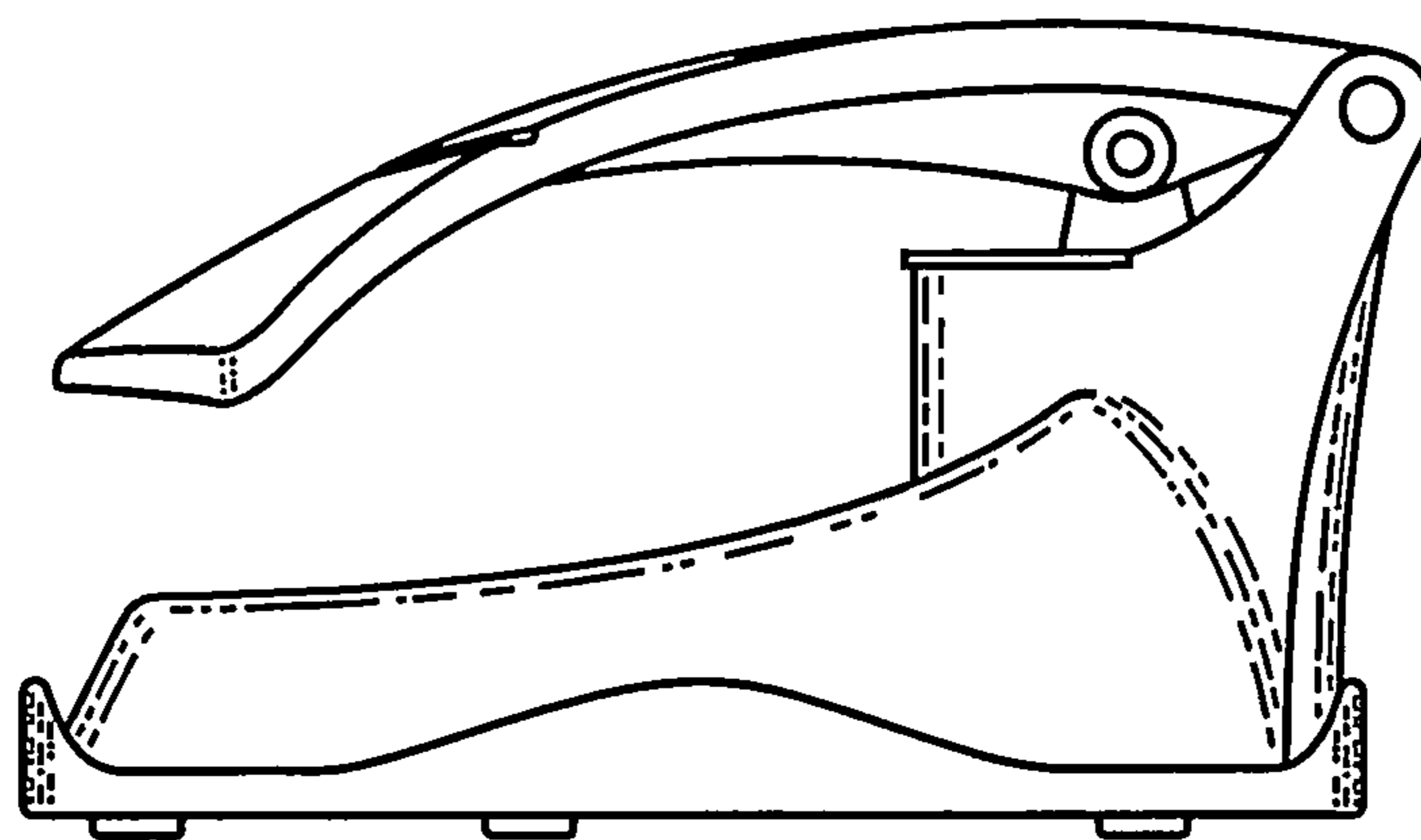

Fig. 3

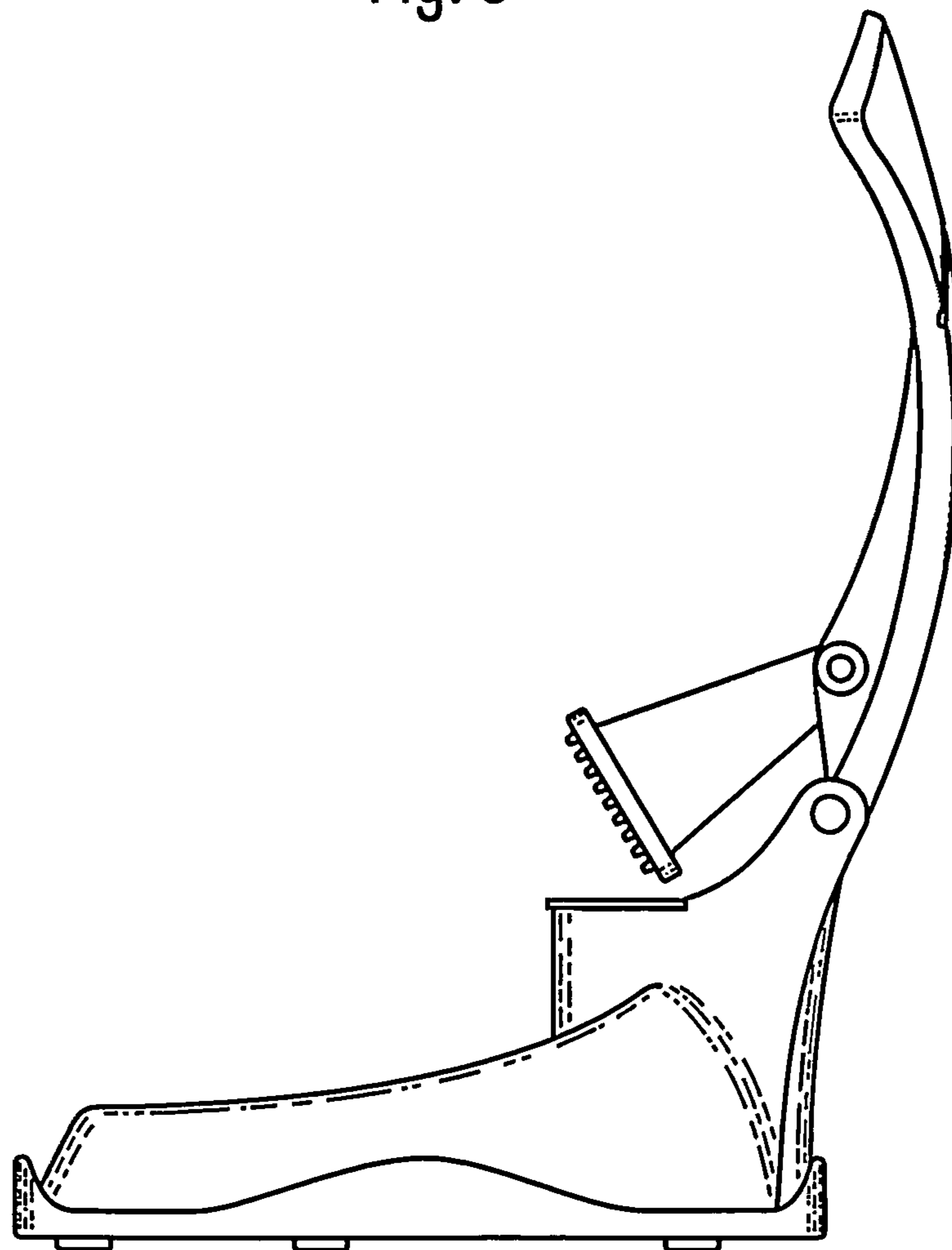

Fig. 4

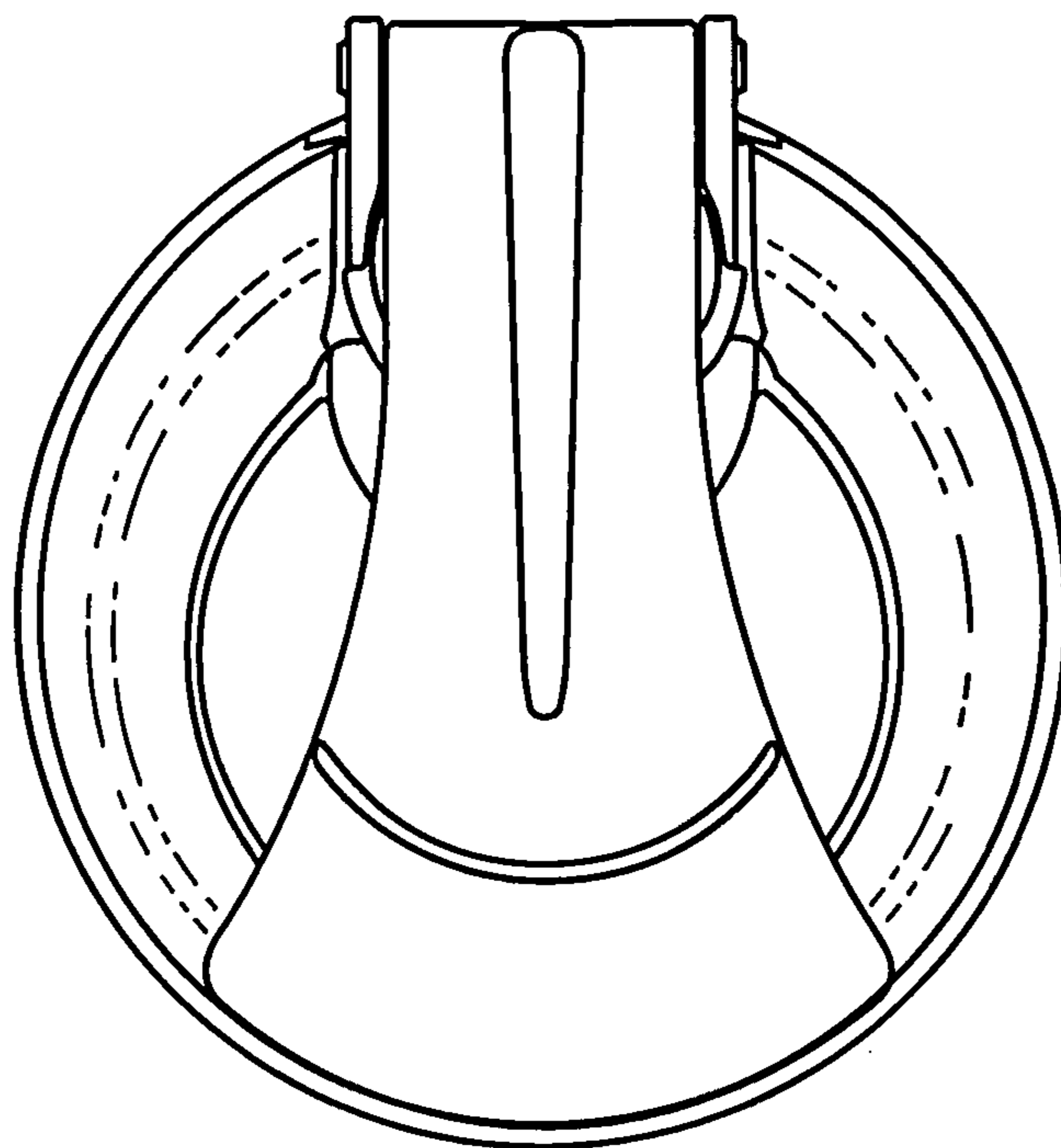

Fig. 5

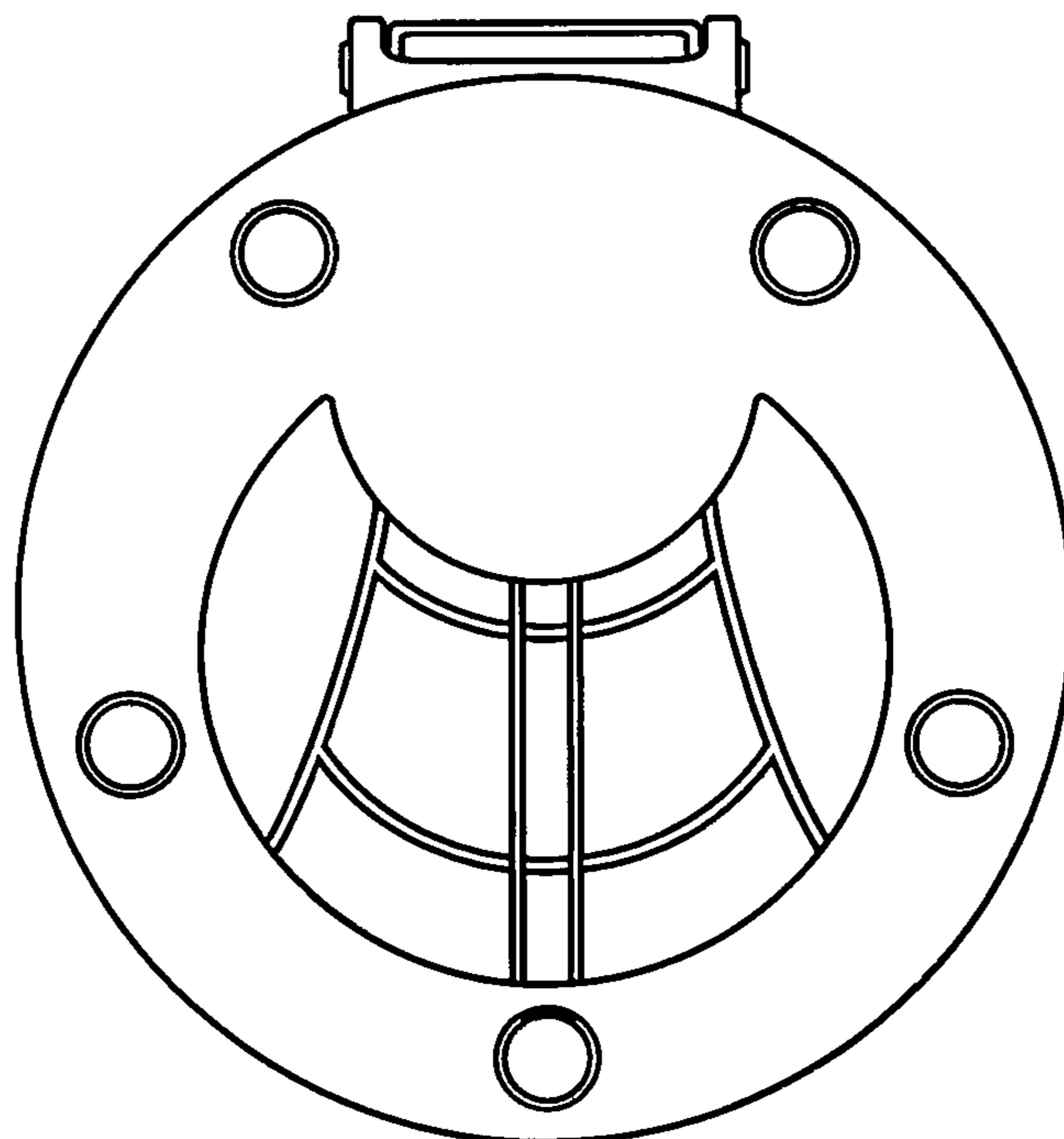

Fig. 6

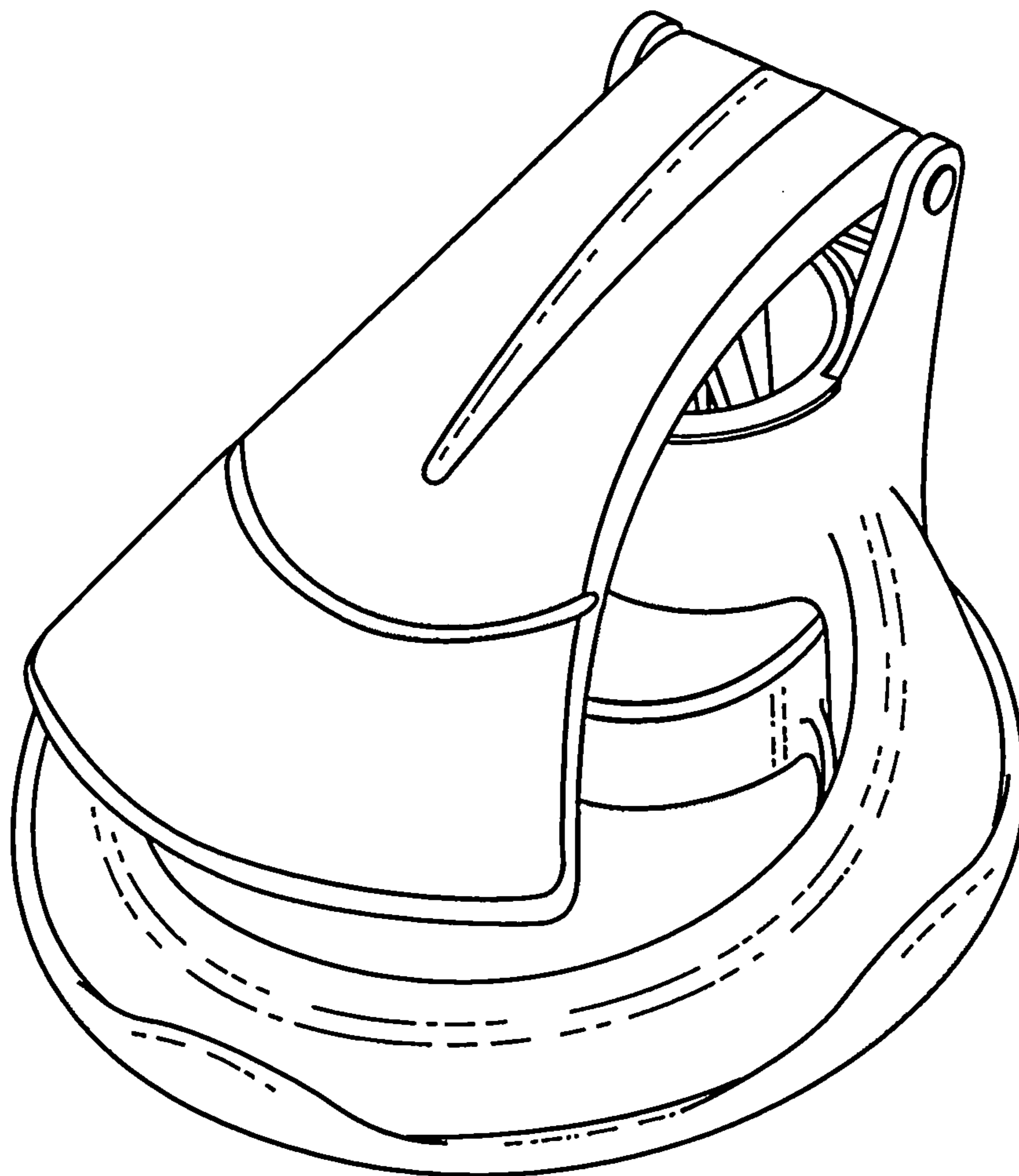

Fig. 7

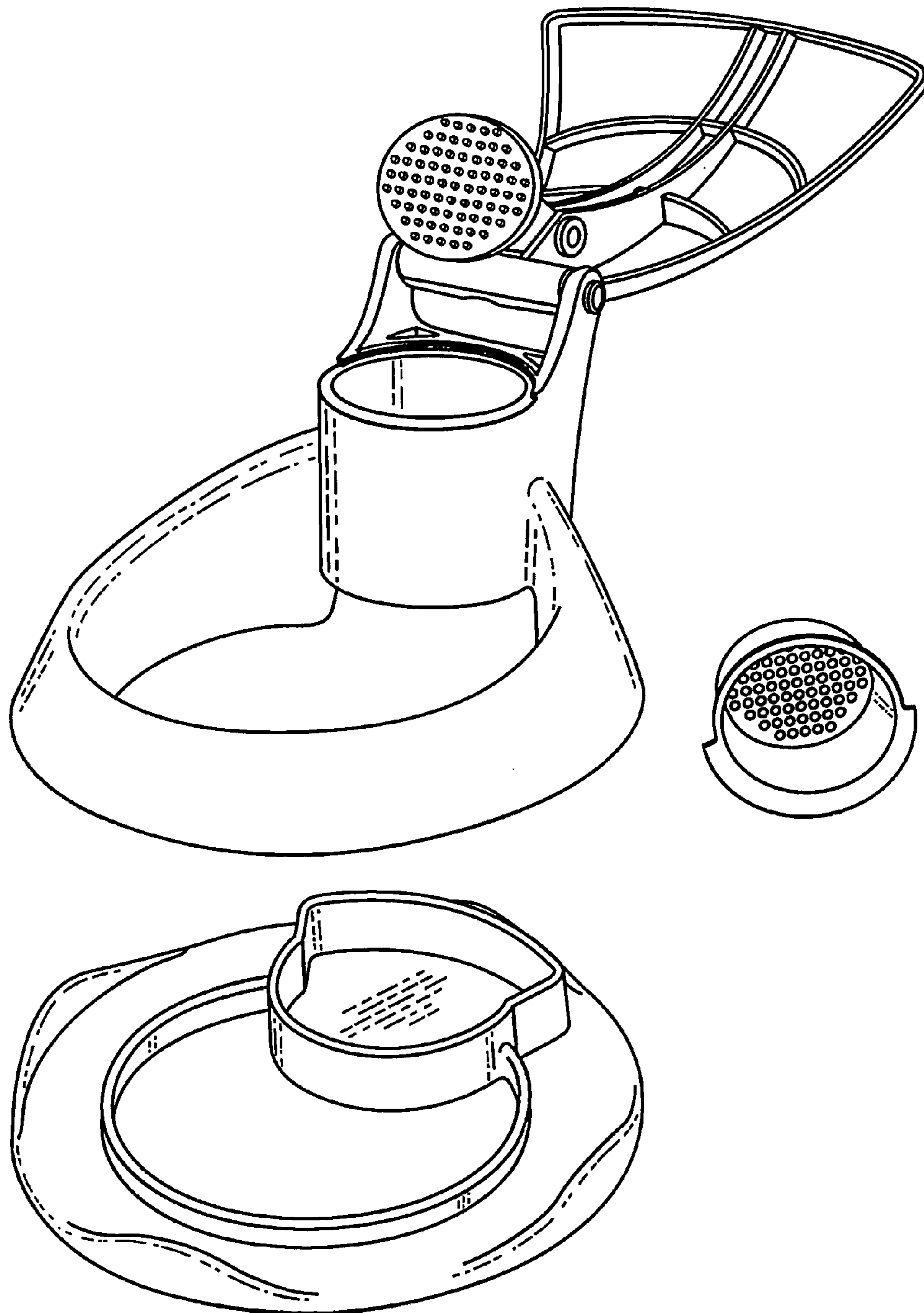

Fig. 8