



US00D723292S

(12) **United States Design Patent**
Castanha et al.

(10) **Patent No.:** **US D723,292 S**
(45) **Date of Patent:** **** Mar. 3, 2015**

(54) **AIRCRAFT INTERIOR DIVAN**

(56) **References Cited**

(71) Applicant: **Embraer S.A.**, Sao Jose dos Campos (BR)
(72) Inventors: **Bruno Kimura Castanha**, Sao Jose dos Campos (BR); **Jay Beever**, Melbourne, FL (US); **Fernando Henrique Da Silva**, Sao Jose dos Campos (BR); **Oliver Turci De Camargo**, Sao Jose dos Campos (BR); **Joshua Rea**, Melbourne, FL (US); **Rainer Zierer**, Melbourne, FL (US)
(73) Assignee: **Embraer S.A.**, São José dos Campos—SP (BR)

U.S. PATENT DOCUMENTS

5,180,120 A *	1/1993	Simpson et al.	244/118.6
D499,261 S *	12/2004	Ricci	D6/381
D515,333 S *	2/2006	Natuzzi	D6/381
D515,334 S *	2/2006	Natuzzi	D6/381
D527,541 S *	9/2006	Natuzzi	D6/381
D541,074 S *	4/2007	Natuzzi	D6/381
D576,820 S *	9/2008	Priestman	D6/381
D577,220 S *	9/2008	Natuzzi	D6/381
D600,037 S *	9/2009	Natuzzi	D6/381
D600,938 S *	9/2009	Natuzzi	D6/381
D611,400 S *	3/2010	Suge et al.	D12/345
D615,476 S *	5/2010	Bock	D12/345
D617,725 S *	6/2010	Collins et al.	D12/345

* cited by examiner

Primary Examiner — Sandra Snapp

(74) *Attorney, Agent, or Firm* — Nixon & Vanderhye P.C.

(**) Term: **14 Years**

(57) **CLAIM**

(21) Appl. No.: **29/455,139**

The ornamental design for “aircraft interior divan,” as shown and described.

(22) Filed: **May 17, 2013**

DESCRIPTION

(51) **LOC (10) Cl.** **06-01**

(52) **U.S. Cl.**
USPC **D6/381**

(58) **Field of Classification Search**
CPC A47C 17/00; A47C 17/02; A47C 17/12;
A47C 17/18; A47C 7/021; A47C 31/00;
A47C 3/16
USPC D6/334, 335, 336, 379, 381, 369, 716,
D6/716.1, 716.2; 297/94, 118, 232, 445.1,
297/448.1, DIG. 7; D12/345

FIG. 1 is a front perspective view thereof, FIG. 2 is a front elevational view thereof, FIG. 3 is a rear elevational view thereof, FIG. 4 is a top plan view thereof, FIG. 5 is a bottom plan view thereof, FIG. 6 is a left side elevational view thereof; and, FIG. 7 is a right side elevational view thereof. The broken lines in the FIGURES represent structures in the environment of the claimed design which do not form any part of the claimed design.

See application file for complete search history.

1 Claim, 6 Drawing Sheets

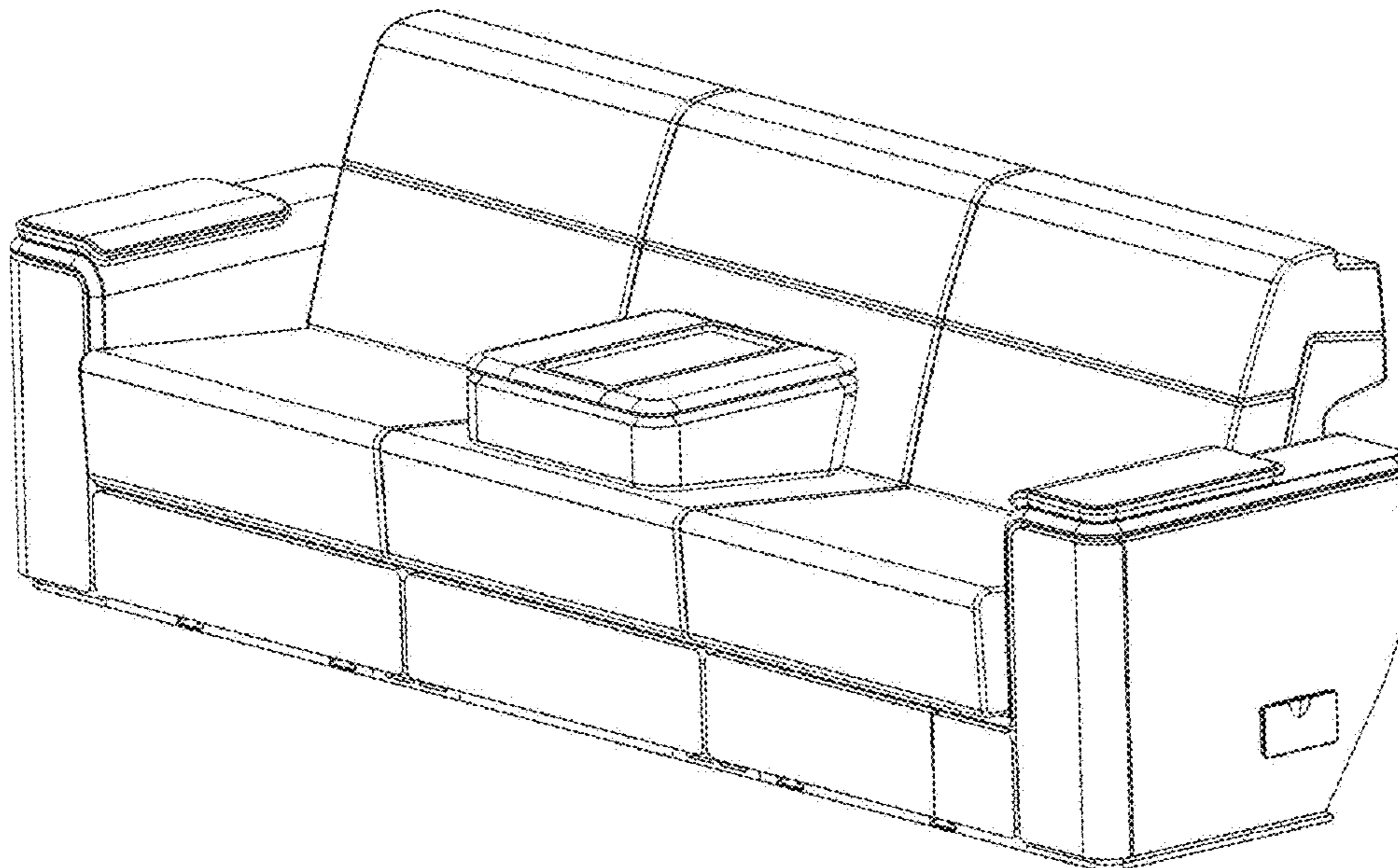

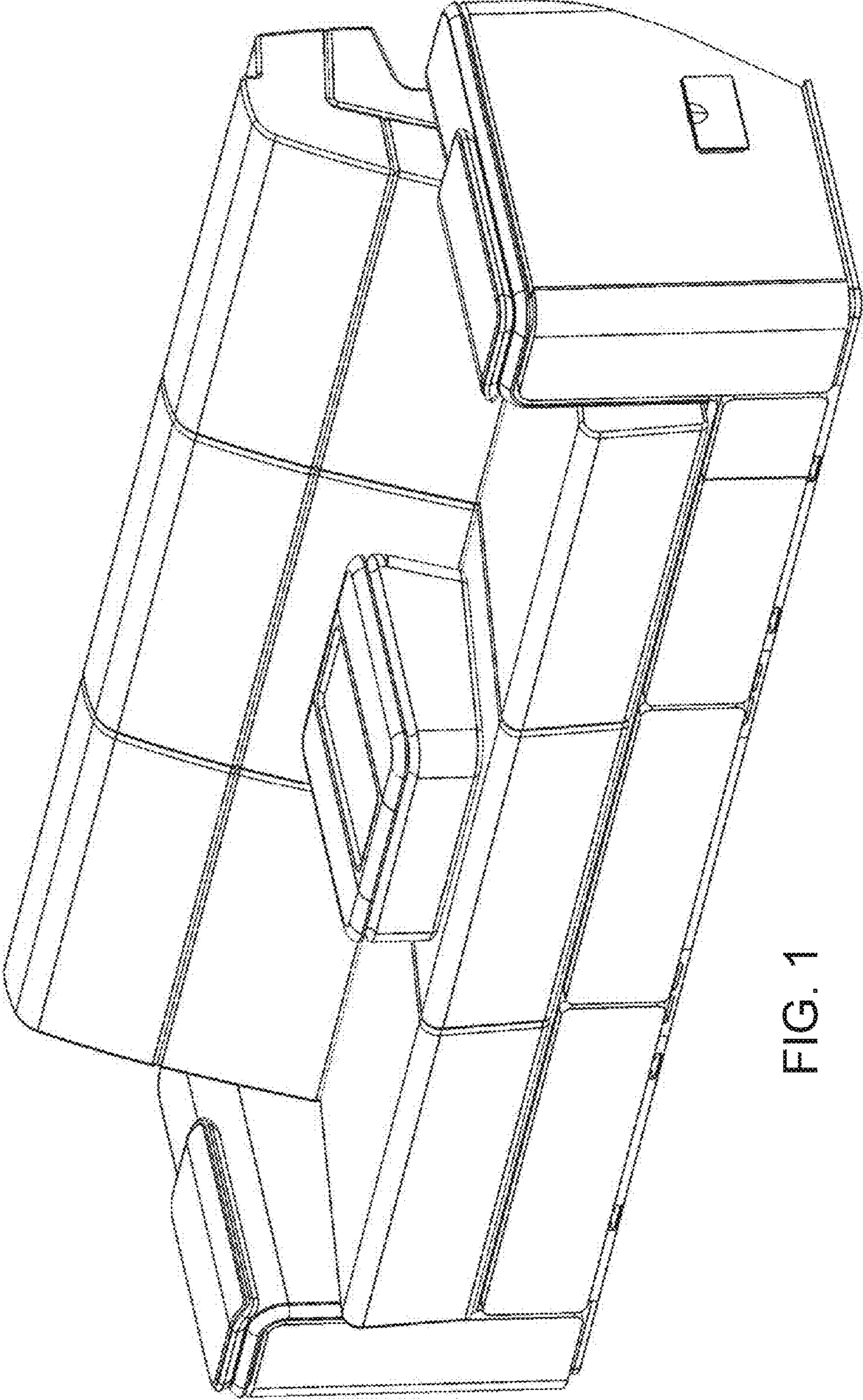

FIG. 1

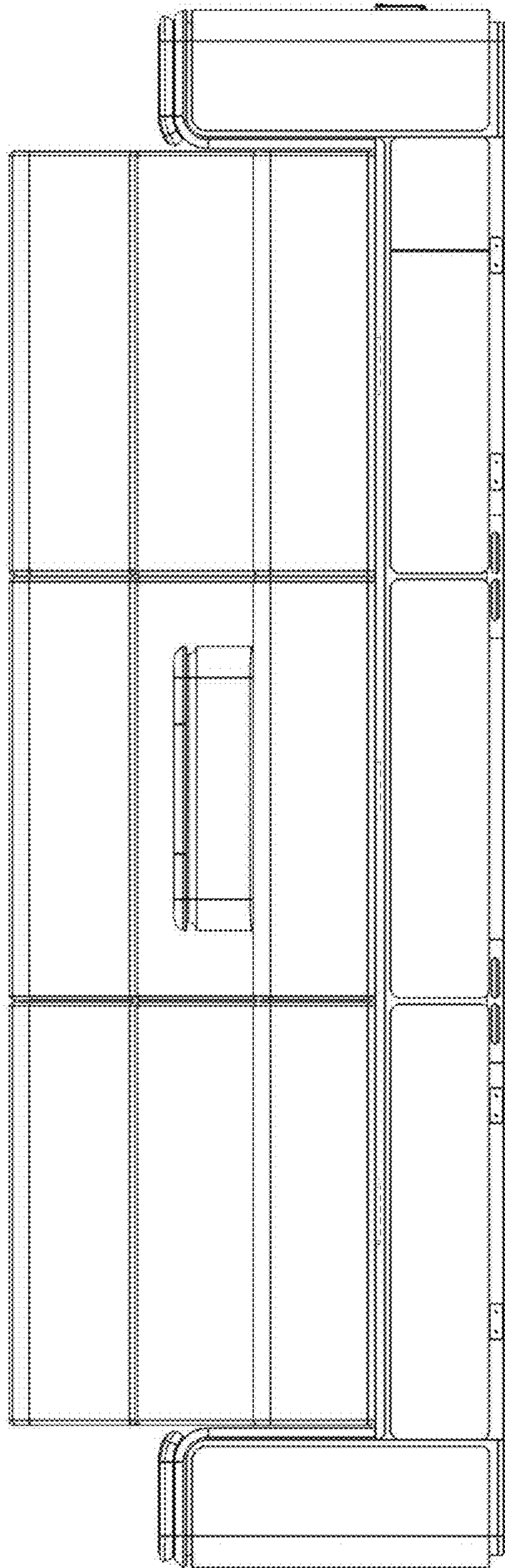

FIG. 2

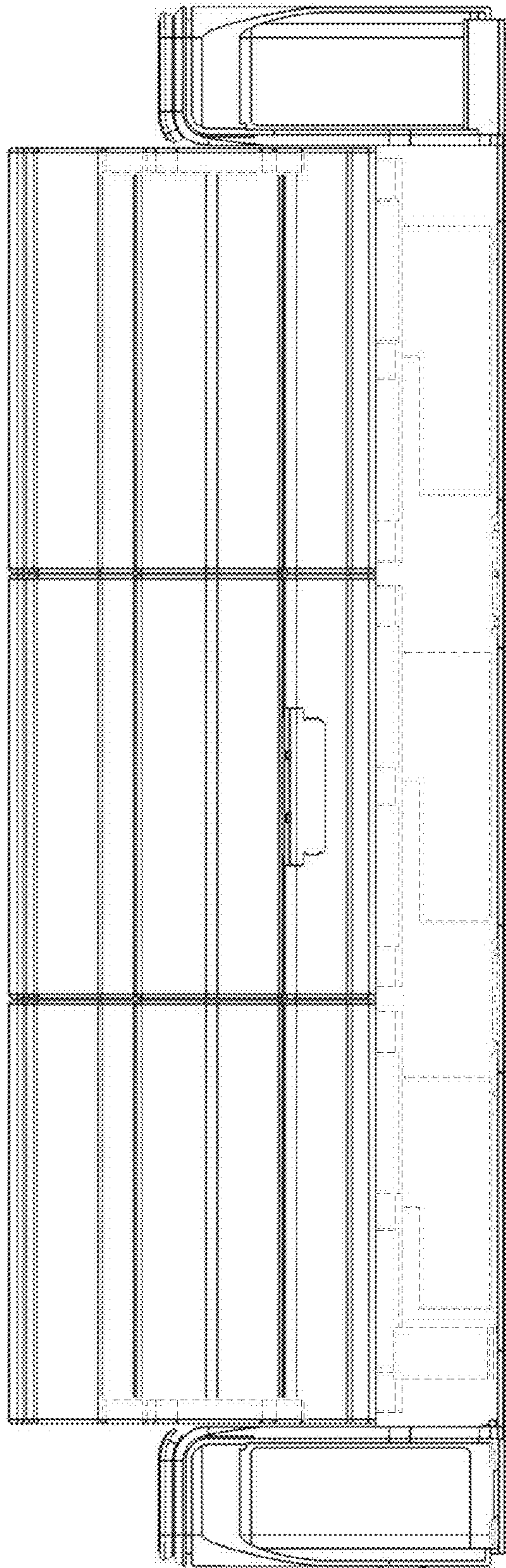

FIG. 3

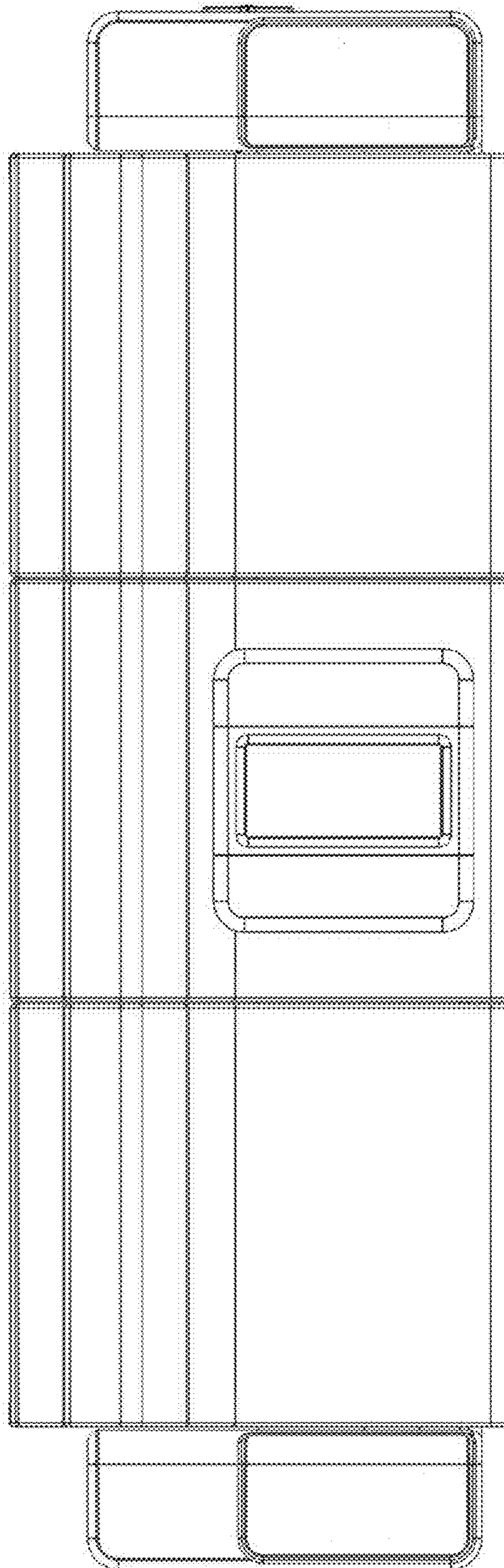

FIG. 4

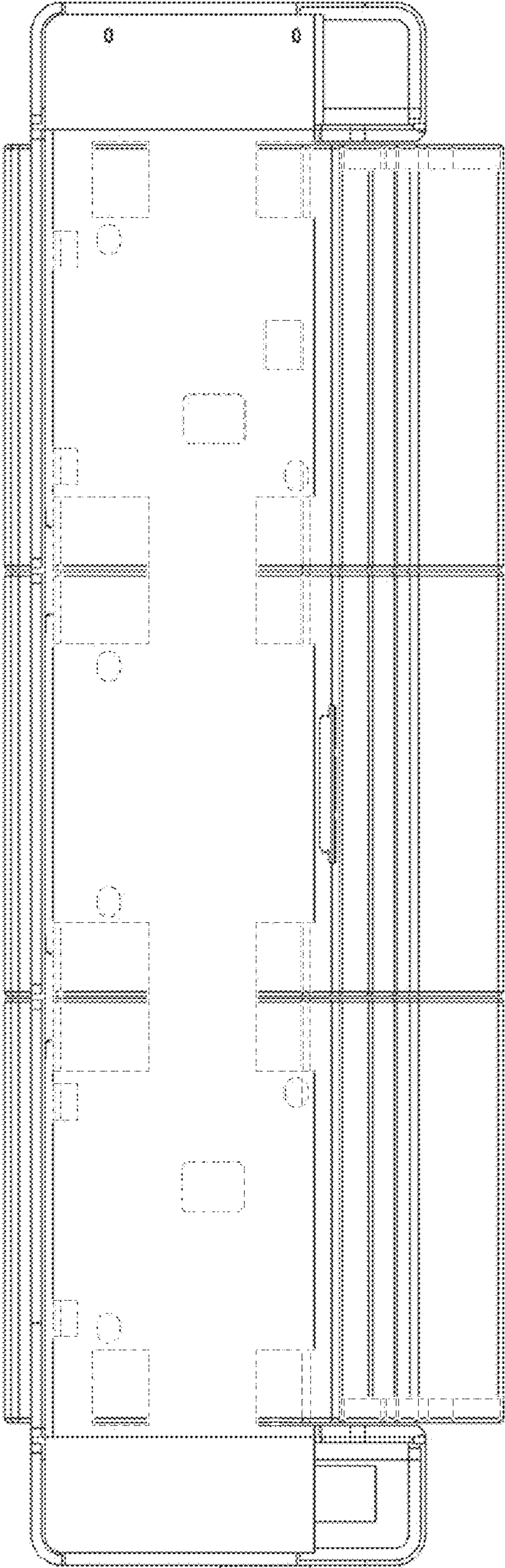

FIG. 5

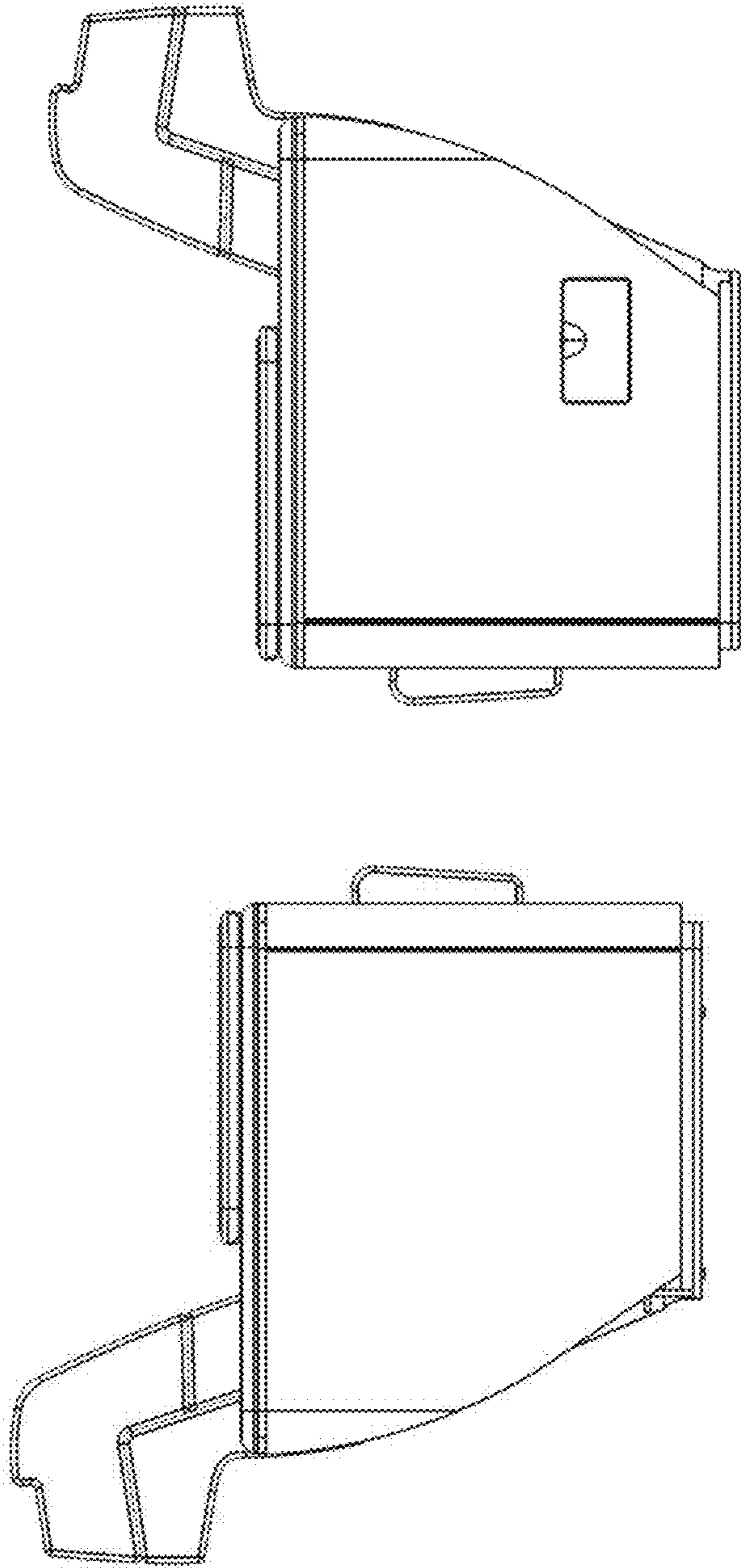

FIG. 7

FIG. 6