



US00D723226S

(12) **United States Design Patent**
Krueger

(10) **Patent No.:** **US D723,226 S**

(45) **Date of Patent:** **** Feb. 24, 2015**

(54) **BIRD FEEDER**

OTHER PUBLICATIONS

(71) Applicant: **Classic Brands, LLC**, Denver, CO (US)

Restriction Requirement, Design U.S. Appl. No. 29/387,517, mailed Oct. 12, 2011, 4 pages.

(72) Inventor: **Bryan Krueger**, Denver, CO (US)

(Continued)

(73) Assignee: **Classic Brands, LLC**, Denver, CO (US)

Primary Examiner — Susan Moon Lee

(**) Term: **14 Years**

(74) *Attorney, Agent, or Firm* — Polsinelli PC

(21) Appl. No.: **29/479,899**

(22) Filed: **Jan. 21, 2014**

(57) **CLAIM**

The ornamental design for a bird feeder, as shown and described.

Related U.S. Application Data

(63) Continuation of application No. 29/437,624, filed on Nov. 19, 2012, now Pat. No. Des. 698,502.

DESCRIPTION

(51) **LOC (10) Cl.** **30-03**

(52) **U.S. Cl.**
USPC **D30/127**

(58) **Field of Classification Search**
USPC D30/121, 124, 126–129, 133, 199,
D30/110–112, 123, 125; 119/52.2, 51.5,
119/61.5, 57.8, 57.9, 52.3, 61.1, 531, 63,
119/428–435, 52.4, 55, 61.3, 69.5, 75, 76;
47/67, 83; 248/318; D11/164, 152;
211/128.1; D27/123; D6/495, 460,
D6/461, 476, 405

See application file for complete search history.

FIG. 1 is a front elevation view of a first embodiment of the bird feeder showing my new design, a back elevation view being substantially similar. All other sides of this first embodiment are essentially structurally the same as in the second embodiment, the only difference being that there is no inner central cord in the upper chamber;

FIG. 2 is a front elevation view of a second embodiment of the bird feeder showing my new design, a back elevation view being substantially similar;

FIG. 3 is a right elevation view of the bird feeder illustrated in FIG. 2, a left elevation view being substantially the same;

FIG. 4 is a front perspective view of the bird feeder illustrated in FIG. 2;

FIG. 5 is a front perspective view of the bird feeder illustrated in FIG. 2 viewed from below;

FIG. 6 is a right perspective view of the bird feeder illustrated in FIG. 2 viewed from below;

FIG. 7 is a top plan view of the bird feeder illustrated in FIG. 2; and,

FIG. 8 is a bottom plan view of the bird feeder illustrated in FIG. 2.
The portion of the looped-hanger in FIGS. 2 through 6 that is shown in broken lines shows the environment only, and forms no part of the claimed design.

(56) **References Cited**

U.S. PATENT DOCUMENTS

117,807 A	8/1871	Orndoff
D8,908 S	1/1876	Wiley
632,167 A	8/1899	Biesmeyer
727,597 A	5/1903	Day
813,954 A	2/1906	Davis
D43,781 S	4/1913	Sanford
1,251,935 A	1/1918	Stevens
1,558,316 A	10/1925	Tipple
1,634,569 A	7/1927	Bray
D81,602 S	7/1930	Teague

(Continued)

1 Claim, 8 Drawing Sheets

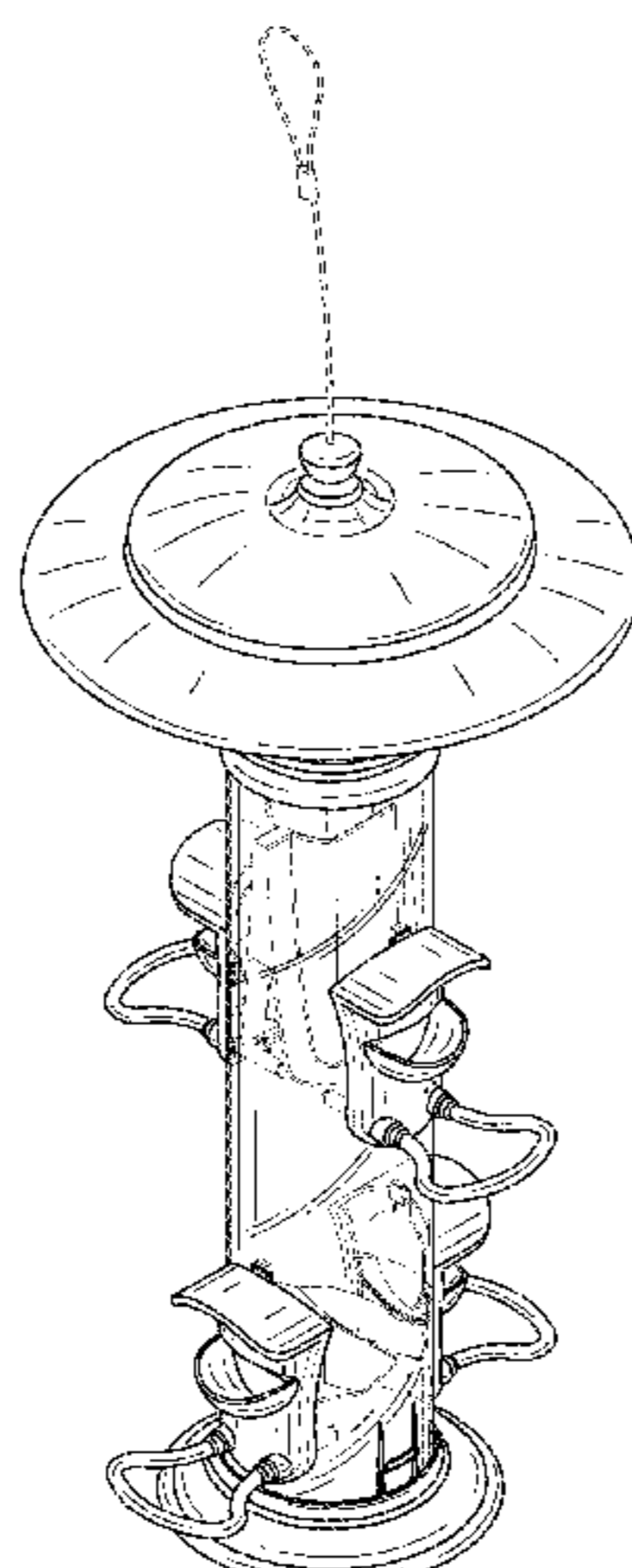

(56)

References Cited

U.S. PATENT DOCUMENTS

1,791,956 A	2/1931	Cowles	
D87,460 S	8/1932	Cook	
1,891,042 A	12/1932	Benoit	
D115,321 S *	6/1939	Pueschel	D30/128
2,350,922 A	6/1944	Planeta	
2,417,178 A	3/1947	Ritter	
D153,759 S	5/1949	Blatt	
2,510,721 A	6/1950	Smith	
D170,150 S	8/1953	Kowap	
D173,658 S	12/1954	Jones	
2,696,803 A	12/1954	Deffenbaugh	
D174,139 S	3/1955	Sadler	
2,725,663 A	12/1955	Mullen	
D178,917 S	10/1956	England et al.	
2,786,446 A	3/1957	Newman	
2,804,844 A	9/1957	Gigliotti	
2,887,987 A	5/1959	Fitzgerald et al.	
2,891,508 A	6/1959	Bower	
2,944,516 A	7/1960	Malloy, Sr.	
2,971,671 A	2/1961	Shakman	
2,987,041 A	6/1961	Bard	
D191,534 S *	10/1961	Curtin et al.	D26/67
3,022,768 A	2/1962	Lynch	
3,051,126 A	8/1962	Merritt et al.	
3,051,303 A	8/1962	Daanen	
D193,558 S *	9/1962	Parry	D30/127
3,090,354 A	5/1963	Merritt et al.	
D195,990 S *	8/1963	Pettengill	D26/67
3,136,296 A	6/1964	Luin	
3,145,690 A	8/1964	Bachman	
D200,778 S	4/1965	Pregont	
3,307,602 A	3/1967	Boster	
3,316,884 A	5/1967	Viggars	
3,372,676 A	3/1968	Williams	
D216,361 S	12/1969	Pappas, Jr.	
D216,750 S *	3/1970	Klein	D7/335
D217,470 S	5/1970	Morrow	
3,526,335 A	9/1970	Swett et al.	
3,568,641 A *	3/1971	Kilham	119/57.8
D229,218 S *	11/1973	Curtis et al.	D26/41
D230,948 S	3/1974	Moon	
D231,369 S *	4/1974	Kilham	D30/127
D234,180 S	1/1975	Dart et al.	
3,901,192 A	8/1975	Adams	
3,941,554 A *	3/1976	Curtis	431/89
3,977,363 A	8/1976	Fisher, Jr.	
D241,860 S	10/1976	Calamia	
D244,786 S	6/1977	Dryden	
4,030,451 A	6/1977	Miller	
D245,349 S *	8/1977	Fisher, Jr.	D30/128
D245,643 S	8/1977	Orfei	
D245,927 S	9/1977	Edwards et al.	
D248,006 S	5/1978	Christian	
4,144,842 A *	3/1979	Schlising	119/52.3
D252,591 S *	8/1979	Hyde, Jr.	D30/127
4,188,913 A *	2/1980	Earl et al.	119/57.9
4,223,637 A	9/1980	Keefe	
D258,338 S	2/1981	Gersin	
D260,843 S	9/1981	Laird et al.	
4,327,669 A	5/1982	Blasbalg	
4,328,605 A	5/1982	Hutchison et al.	
D266,611 S	10/1982	Metts et al.	
D267,355 S	12/1982	Blasbalg	
D268,056 S	2/1983	Campbell-Kelly et al.	
4,389,975 A	6/1983	Fisher, Jr.	
D272,507 S	2/1984	Conti	
D272,508 S	2/1984	Conti	
4,444,324 A	4/1984	Grenell	
D274,563 S	7/1984	Blasbalg	
D277,514 S	2/1985	Bescherer	
D278,168 S *	3/1985	Latham et al.	D30/127
D278,559 S *	4/1985	Latham et al.	D30/127
D278,751 S	5/1985	Seager	
D282,019 S	12/1985	Kilham	
D284,033 S	5/1986	Brodsky	
D289,143 S	4/1987	Guillaume	
D289,210 S	4/1987	Tucker et al.	
D289,211 S	4/1987	Riha	
4,664,066 A	5/1987	Steuernagel et al.	
D290,769 S	7/1987	Taylor	
D290,773 S	7/1987	Liethen	
D292,372 S	10/1987	Sykes	
4,712,512 A	12/1987	Schrieb et al.	
4,732,112 A	3/1988	Fenner et al.	
4,798,172 A	1/1989	Clarke	
D299,770 S	2/1989	Coffer	
4,821,681 A	4/1989	Tucker	
RE32,970 E *	7/1989	Furlani	119/52.3
4,896,628 A	1/1990	Kadunce	
4,901,673 A	2/1990	Overstreet	
4,938,168 A	7/1990	Meidell	
D309,858 S	8/1990	Meyersburg	
4,974,547 A	12/1990	Graham	
4,986,219 A	1/1991	Harris	
4,996,947 A	3/1991	Petrides	
5,033,411 A	7/1991	Brucker	
D324,436 S	3/1992	Embree	
5,105,765 A	4/1992	Loken	
D326,003 S	5/1992	Embree	
5,140,945 A	8/1992	Barnhart et al.	
D329,892 S	9/1992	Brister	
5,168,830 A	12/1992	Deglis	
5,191,857 A	3/1993	Boaz	
D334,635 S	4/1993	Wenstrand	
D335,006 S *	4/1993	Blasbalg	D30/127
5,207,180 A	5/1993	Graham	
D337,271 S	7/1993	Pezzoli et al.	
D338,317 S	8/1993	Woodward	
5,247,904 A	9/1993	Anderson	
5,269,242 A	12/1993	Toldi	
D343,030 S	1/1994	Harwick, Jr.	
5,289,796 A	3/1994	Armstrong	
5,291,855 A	3/1994	Lavery	
D349,981 S *	8/1994	Fasino	D30/127
D351,691 S	10/1994	Lipton	
D351,692 S	10/1994	Cossey	
D352,575 S *	11/1994	Bransky et al.	D30/127
5,361,723 A	11/1994	Burleigh	
D359,592 S *	6/1995	Fenton et al.	D30/124
D360,495 S	7/1995	Sanderson	
D360,829 S	8/1995	Leeds	
5,463,979 A *	11/1995	Fasino	119/54
D366,413 S	1/1996	Tober	
5,479,879 A	1/1996	Biek	
D370,313 S	5/1996	Nottingham et al.	
D371,230 S	6/1996	Nottingham et al.	
D371,979 S	7/1996	Nottingham et al.	
5,533,467 A	7/1996	Lancia	
5,558,040 A	9/1996	Colwell et al.	
D376,731 S	12/1996	Lin	
D380,066 S	6/1997	Green et al.	
5,655,477 A	8/1997	Hoffman et al.	
D383,878 S	9/1997	Merino et al.	
D386,835 S	11/1997	Passamare	
D386,836 S	11/1997	Hunt	
5,682,835 A	11/1997	Walter et al.	
5,701,841 A	12/1997	Fasino	
5,711,247 A	1/1998	Henshaw	
5,775,256 A	7/1998	Henshaw	
5,782,200 A	7/1998	Knowles et al.	
D397,529 S	8/1998	Fuller et al.	
5,791,286 A *	8/1998	Taussig et al.	119/52.3
D399,611 S	10/1998	Ericson et al.	
5,829,382 A	11/1998	Garrison	
D406,307 S	3/1999	Kang	
D408,420 S	4/1999	Buter	
5,964,183 A *	10/1999	Czipri	119/52.3
5,975,015 A *	11/1999	Runyon et al.	119/52.1
D420,176 S *	2/2000	Heinzeroth	D30/127
D425,259 S	5/2000	Lang	
6,079,361 A	6/2000	Bowell et al.	
D428,537 S	7/2000	Miller	
6,095,087 A	8/2000	Bloedorn	
6,119,627 A	9/2000	Banyas et al.	

(56)

References Cited

U.S. PATENT DOCUMENTS

D431,760	S	10/2000	Sullivan	
D433,633	S	11/2000	La Fata	
6,145,477	A	11/2000	Jansen	
D434,980	S	12/2000	Suzuki	
D440,361	S	4/2001	Colwell	
D440,677	S *	4/2001	Long et al.	D26/40
6,213,054	B1	4/2001	Marshall	
6,253,706	B1	7/2001	Sloop	
D448,290	S	9/2001	Schultz et al.	
6,305,321	B1	10/2001	Potente	
6,360,690	B1	3/2002	Canby	
6,415,737	B2	7/2002	Banyas et al.	
6,418,878	B1	7/2002	Cathell et al.	
D461,827	S	8/2002	Koebbe	
6,427,629	B1	8/2002	Lush	
6,450,120	B1	9/2002	Nylen	
D466,255	S	11/2002	Kuelbs	
D466,656	S	12/2002	Kuelbs et al.	
D470,630	S	2/2003	Kuelbs	
D471,327	S	3/2003	Kuelbs	
6,543,384	B2	4/2003	Cote	
6,546,894	B2	4/2003	Chrisco et al.	
6,561,128	B1	5/2003	Carter	
6,584,933	B1	7/2003	Stone	
6,591,781	B2 *	7/2003	Hardison	119/57.9
D478,475	S	8/2003	Backes et al.	
6,622,654	B2	9/2003	Fasino	
6,659,041	B1	12/2003	Curts	
D485,930	S	1/2004	Chen	
D487,809	S *	3/2004	Leung et al.	D26/40
6,701,867	B1	3/2004	Garrison	
D490,576	S	5/2004	Rich et al.	
D491,019	S	6/2004	Marsden et al.	
D491,302	S *	6/2004	Krieger et al.	D26/40
D493,053	S	7/2004	Snell	
D495,900	S	9/2004	Mayse	
D496,119	S *	9/2004	Bucher et al.	D26/67
6,789,916	B2	9/2004	Ruggles	
6,792,891	B1	9/2004	Coburn et al.	
D497,226	S	10/2004	Nauert	
D497,406	S	10/2004	King	
D497,458	S	10/2004	Nauert	
D499,503	S *	12/2004	Hon et al.	D26/67
6,830,009	B1	12/2004	Kuelbs	
D503,006	S *	3/2005	May et al.	D26/40
D503,019	S	3/2005	Swift et al.	
6,863,024	B1 *	3/2005	Obenshain	119/57.8
6,866,004	B1	3/2005	Lush	
D504,547	S	4/2005	Nauert	
D504,746	S	5/2005	Lee	
D505,216	S *	5/2005	Chen	D26/40
D505,521	S	5/2005	Schrodt	
D505,755	S	5/2005	Lundstrom et al.	
6,895,894	B2	5/2005	Fort, II	
6,901,882	B2	6/2005	Kuelbs	
6,945,192	B2	9/2005	Cote	
D511,866	S	11/2005	Lundstrom et al.	
D512,800	S	12/2005	Jung et al.	
6,986,322	B2	1/2006	Lumpkin et al.	
D515,916	S	2/2006	Bleuer	
7,017,517	B2	3/2006	Paquette	
7,017,521	B2	3/2006	Kuelbs	
D518,380	S	4/2006	Moran	
7,021,241	B2	4/2006	Nock	
7,032,538	B1	4/2006	Lush	
D523,141	S	6/2006	Massey	
D524,490	S	7/2006	Obenshain	
7,096,821	B2	8/2006	Ruff	
D528,692	S *	9/2006	Chen	D26/67
D530,034	S *	10/2006	Hon et al.	D26/67
D531,341	S *	10/2006	Chen	D26/67
D532,141	S *	11/2006	Chen	D26/67
D533,293	S *	12/2006	Chen	D26/67
D533,294	S *	12/2006	Chen	D26/67
D533,295	S *	12/2006	Chen	D26/67
D533,676	S *	12/2006	Hon et al.	D26/67
D535,425	S *	1/2007	Chen	D26/67
7,168,392	B2	1/2007	Kuelbs	
7,185,605	B1	3/2007	Lush	
D539,957	S *	4/2007	Luo	D26/67
D539,991	S *	4/2007	Petrie et al.	D30/127
D540,349	S	4/2007	Waki	
D542,659	S	5/2007	Meether et al.	
D543,256	S	5/2007	Chen	
D544,942	S	6/2007	Chen	
7,234,416	B2	6/2007	Hoff	
D548,587	S	8/2007	DuVal et al.	
7,258,075	B1	8/2007	Jones et al.	
7,287,486	B2	10/2007	Hunter	
D556,568	S	12/2007	DuVal	
D557,848	S *	12/2007	Chen	D26/67
D557,849	S *	12/2007	Chen	D26/67
D557,850	S *	12/2007	Chen	D26/67
7,302,911	B1 *	12/2007	Lush	119/57.8
D561,021	S	2/2008	DuVal et al.	
D561,040	S	2/2008	Sequeira	
D563,586	S *	3/2008	Lee et al.	D26/67
D567,098	S	4/2008	Sequeira	
D567,984	S *	4/2008	Chen	D26/67
D568,754	S	5/2008	Sequeira	
7,370,607	B2	5/2008	O'Dell	
7,373,901	B2	5/2008	Baynard	
D572,866	S *	7/2008	Bloedorn	D30/127
D574,103	S *	7/2008	Minami et al.	D26/67
D574,536	S *	8/2008	Sanoner	D26/67
D574,537	S *	8/2008	Sanoner	D26/67
D575,118	S	8/2008	Bignon	
D575,429	S *	8/2008	Shiu	D26/40
D575,591	S	8/2008	Bonetti	
7,409,922	B1	8/2008	Baynard et al.	
7,448,346	B1 *	11/2008	Stone et al.	119/52.3
7,484,475	B2	2/2009	Milliner	
7,503,282	B1	3/2009	Lush	
7,506,611	B1	3/2009	Lush	
D591,589	S	5/2009	Myers et al.	
D592,046	S	5/2009	Myers et al.	
7,530,330	B1	5/2009	Valle	
D594,586	S *	6/2009	Chen	D26/67
D594,587	S *	6/2009	Chen	D26/67
7,540,260	B2	6/2009	Rich et al.	
7,540,262	B2	6/2009	Kuelbs	
7,549,394	B2	6/2009	Nock	
D596,033	S	7/2009	Zach et al.	
D599,159	S	9/2009	Stein	
D599,933	S *	9/2009	van Klinken	D26/67
D599,938	S *	9/2009	Sabernig	D26/67
D603,996	S *	11/2009	Chen	D26/67
D604,436	S *	11/2009	Poon	D26/40
D604,441	S *	11/2009	Chen	D26/67
7,610,875	B2	11/2009	Webber	
D605,803	S *	12/2009	Chen	D26/67
D606,447	S	12/2009	West et al.	
D607,612	S	1/2010	Yang	
D609,864	S	2/2010	Tsai	
7,654,225	B2	2/2010	Madsen et al.	
7,669,553	B2	3/2010	White et al.	
D616,131	S *	5/2010	Chen	D26/67
D616,133	S *	5/2010	Chen	D26/67
7,726,259	B2	6/2010	Hepp et al.	
7,739,982	B2	6/2010	Cote	
7,743,732	B2	6/2010	Webber	
D623,805	S	9/2010	Vosbikian	
7,798,099	B2	9/2010	Vosbikian	
7,874,264	B2	1/2011	McMullen	
D636,238	S	4/2011	Elmelund	
7,930,994	B2	4/2011	Stone et al.	
D638,588	S	5/2011	Vosbikian	
D640,407	S *	6/2011	Chen	D26/67
7,958,845	B2	6/2011	Gardner	
D643,442	S	8/2011	Sato et al.	
D643,855	S	8/2011	Taniguchi et al.	
7,997,434	B2	8/2011	Benetti	
8,006,642	B2	8/2011	Vosbikian	
D649,299	S	11/2011	Lush	

(56)

References Cited

OTHER PUBLICATIONS

U.S. PATENT DOCUMENTS

D649,302	S	11/2011	Hickok	
D650,105	S *	12/2011	Crawford et al.	D26/41
D652,059	S	1/2012	Sato et al.	
D656,690	S	3/2012	Tu	
D657,399	S	4/2012	Nemoto	
8,156,894	B1	4/2012	Krah	
D658,684	S	5/2012	Roman	
D663,457	S *	7/2012	Ho et al.	D26/67
D664,437	S	7/2012	Barel	
8,230,809	B2	7/2012	Cote	
8,245,666	B2	8/2012	Sena et al.	
D670,013	S *	10/2012	Bertken	D26/40
8,276,541	B2	10/2012	LoRocco et al.	
D671,276	S	11/2012	Krueger	
D671,277	S	11/2012	Vosbikian et al.	
D671,692	S *	11/2012	Carter	D30/124
8,347,818	B2	1/2013	Cowger et al.	
D676,614	S	2/2013	Fields et al.	
D676,995	S *	2/2013	Ho et al.	D26/67
D677,016	S *	2/2013	Carter	D30/127
D678,574	S *	3/2013	Chen	D26/67
8,413,605	B2 *	4/2013	Baynard et al.	119/52.3
D689,639	S *	9/2013	Chung	D26/40
D692,191	S *	10/2013	Stephens et al.	D30/127
D694,931	S *	12/2013	Meyer et al.	D26/67
D698,062	S *	1/2014	Burke	D26/67
D698,502	S *	1/2014	Krueger	D30/127
D698,964	S *	2/2014	Helms et al.	D26/67
D698,965	S *	2/2014	Helms et al.	D26/67
D708,401	S *	7/2014	Krueger	D30/127
8,833,301	B2 *	9/2014	Donegan et al.	119/57.8
8,833,302	B2 *	9/2014	Donegan et al.	119/57.8
2003/0033985	A1	2/2003	Hardison	
2003/0136347	A1	7/2003	Fasino	
2003/0226514	A1	12/2003	Cote	
2004/0216684	A1 *	11/2004	Obenshain	119/57.9
2004/0231606	A1	11/2004	Nock	
2004/0261726	A1	12/2004	Lumpkin	
2005/0120967	A1	6/2005	Ruff	
2005/0257749	A1	11/2005	Kuelbs	
2005/0263085	A1	12/2005	Rich	
2006/0225658	A1	10/2006	Baynard	
2006/0266295	A1 *	11/2006	McDarren	119/57.8
2006/0272585	A1	12/2006	O'Dell	
2007/0034160	A1	2/2007	Nock	
2007/0163506	A1	7/2007	Bloedorn	
2007/0227453	A1 *	10/2007	Puckett et al.	119/57.8
2007/0227454	A1	10/2007	Fahey	
2008/0022936	A1	1/2008	Stone et al.	
2008/0105206	A1	5/2008	Rich et al.	
2008/0127902	A1	6/2008	Bent N. et al.	
2008/0134979	A1	6/2008	Crocker	
2008/0210172	A1	9/2008	Waikas	
2008/0276874	A1 *	11/2008	Evans	119/57.8
2008/0302304	A1	12/2008	Mayfield	
2009/0020075	A1 *	1/2009	Wood et al.	119/57.8
2009/0223456	A1	9/2009	Hunter et al.	
2009/0283046	A1 *	11/2009	Black	119/52.3
2010/0089330	A1	4/2010	McMullen	
2010/0258054	A1	10/2010	Frazier	
2010/0288200	A1	11/2010	Lush	
2011/0067637	A1	3/2011	Baynard	
2011/0073043	A1	3/2011	Dault	
2011/0083609	A1 *	4/2011	Cote	119/52.2
2011/0088626	A1	4/2011	Hepp et al.	
2011/0180004	A1	7/2011	Humphries et al.	
2012/0055410	A1	3/2012	Cote	
2012/0234249	A1	9/2012	Gaze	

Response to Restriction, Design U.S. Appl. No. 29/387,517, filed Dec. 12, 2011, 2 pages.
 Non-Final Office Action, Design U.S. Appl. No. 29/387,517, mailed Mar. 12, 2012, 7 pages.
 Response to Non-Final Office Action, Design U.S. Appl. No. 29/387,517, filed Jun. 12, 2012, 13 pages.
 Notice of Allowance, Design U.S. Appl. No. 29/387,517, mailed Jul. 3, 2012, 11 pages.
 Non-Final Office Action, U.S. Appl. No. 13/107,841, mailed Jun. 27, 2012, 9 pages.
 Restriction Requirement, Design U.S. Appl. No. 29/416,890, filed Aug. 2, 2012, 5 pages.
 Response to Restriction Requirement, Design U.S. Appl. No. 29/416,890, filed Sep. 4, 2012, 13 pages.
 Response to Non-Final Office Action, U.S. Appl. No. 13/107,841, filed Nov. 27, 2012, 21 pages.
 Notice of Allowance, U.S. Appl. No. 29/387,518, mailed Dec. 21, 2012, 24 pages.
 Notice of Allowance, U.S. Appl. No. 29/416,890, mailed Dec. 20, 2012, 24 pages.
 Final Office Action, U.S. Appl. No. 13/107,841, mailed Jan. 9, 2013, 22 pages.
 Ex Parte Quayle Action, U.S. Appl. No. 29/437,624, mailed Jun. 7, 2013, 23 pages.
 Response to Ex Parte Quayle Action, U.S. Appl. No. 29/437,624, filed Aug. 7, 2013, 14 pages.
 Response to Final Office Action, U.S. Appl. No. 13/107,841, filed Jul. 8, 2013, 10 pages.
 Notice of Allowance, U.S. Appl. No. 29/437,624, mailed Sep. 18, 2013, 23 pages.
 Non-Final Office Action, U.S. Appl. No. 13/107,841, mailed Aug. 19, 2013, 20 pages.
 Response to Non-Final Office Action, U.S. Appl. No. 13/107,841, filed Jan. 22, 2014, 12 pages.
 Non-Final Office Action, U.S. Appl. No. 13/420,086, mailed Oct. 7, 2013, 23 pages.
 Non-Final Office Action, U.S. Appl. No. 13/855,565, mailed Sep. 27, 2013, 32 pages.
 Non-Final Office Action, U.S. Appl. No. 13/855,523, mailed Sep. 30, 2013, 29 pages.
 Ex Parte Quayle Action, U.S. Appl. No. 29/437,619, mailed Nov. 27, 2013, 22 pages.
 Restriction Requirement, Design U.S. Appl. No. 29/438,289, mailed Dec. 20, 2013, 24 pages.
 Response to Ex Parte Quayle Action, U.S. Appl. No. 29/437,619, filed Jan. 27, 2014, 15 pages.
 Notice of Allowance, U.S. Appl. No. 29/437,619, mailed Feb. 14, 2014, 19 pages.
 Response to Restriction Requirement, Design U.S. Appl. No. 29/438,289, filed Jan. 21, 2014, 2 pages.
 Ex Parte Quayle Action, Design U.S. Appl. No. 29/438,289, mailed Mar. 6, 2014, 11 pages.
 Response to Non-Final Office Action, U.S. Appl. No. 13/855,523, filed Jan. 27, 2014, 6 pages.
 Response to Non-Final Office Action, U.S. Appl. No. 13/855,565, filed Jan. 27, 2014, 6 pages.
 Response to Non-Final Office Action, U.S. Appl. No. 13/420,086, filed Apr. 7, 2014, 16 pages.
 Restriction Requirement, Design U.S. Appl. No. 29/438,291, mailed Apr. 1, 2014, 24 pages.

* cited by examiner

FIG. 1

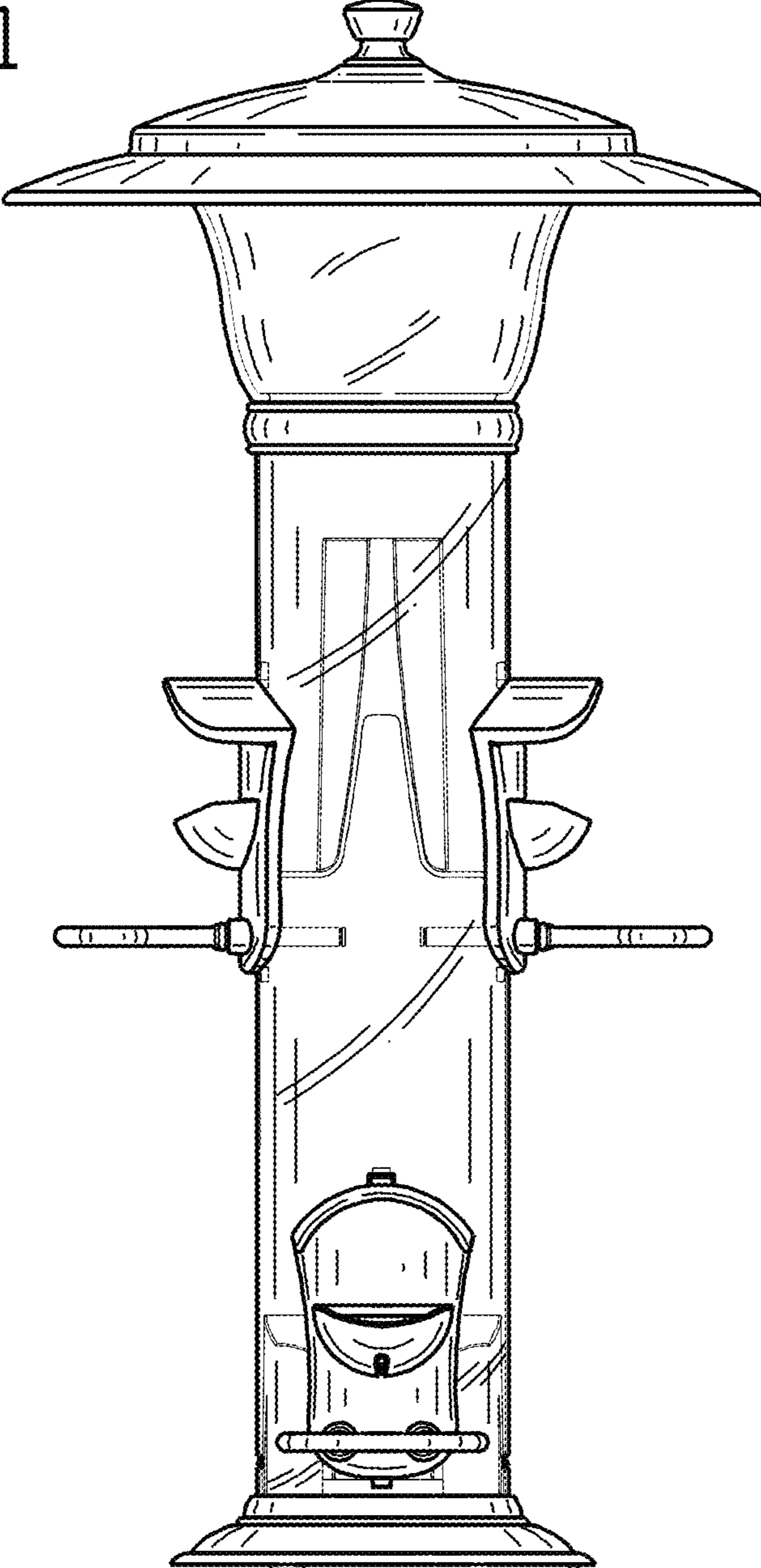

FIG. 2

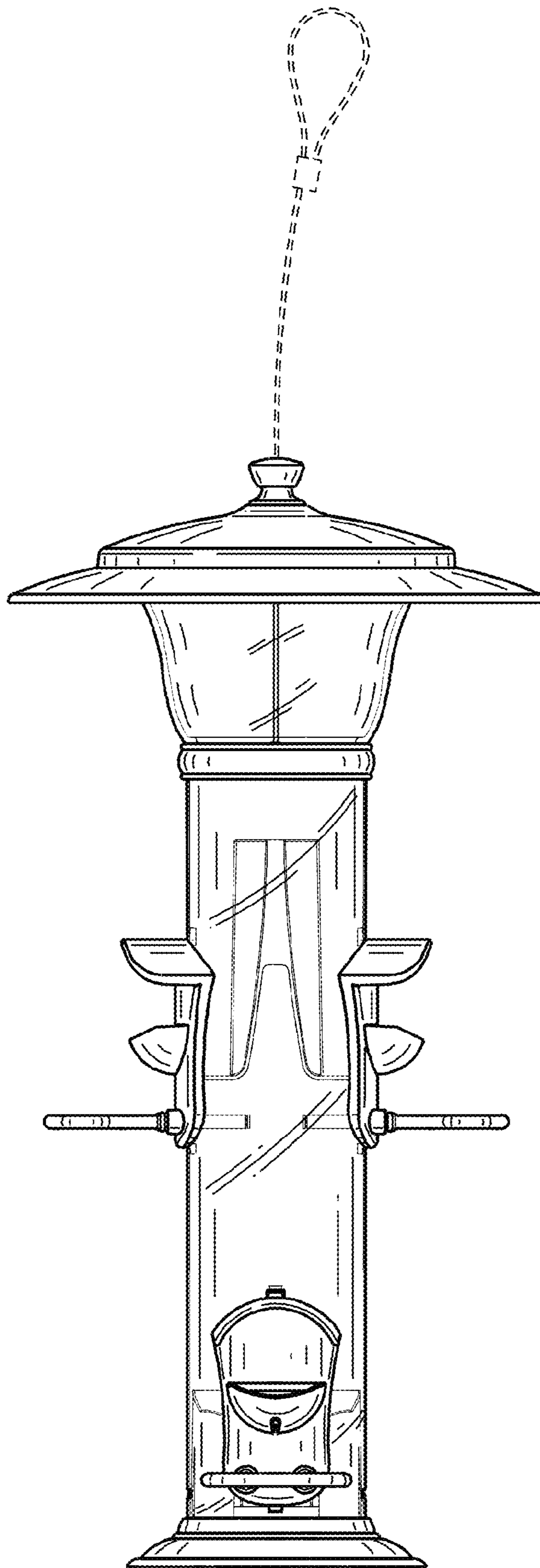
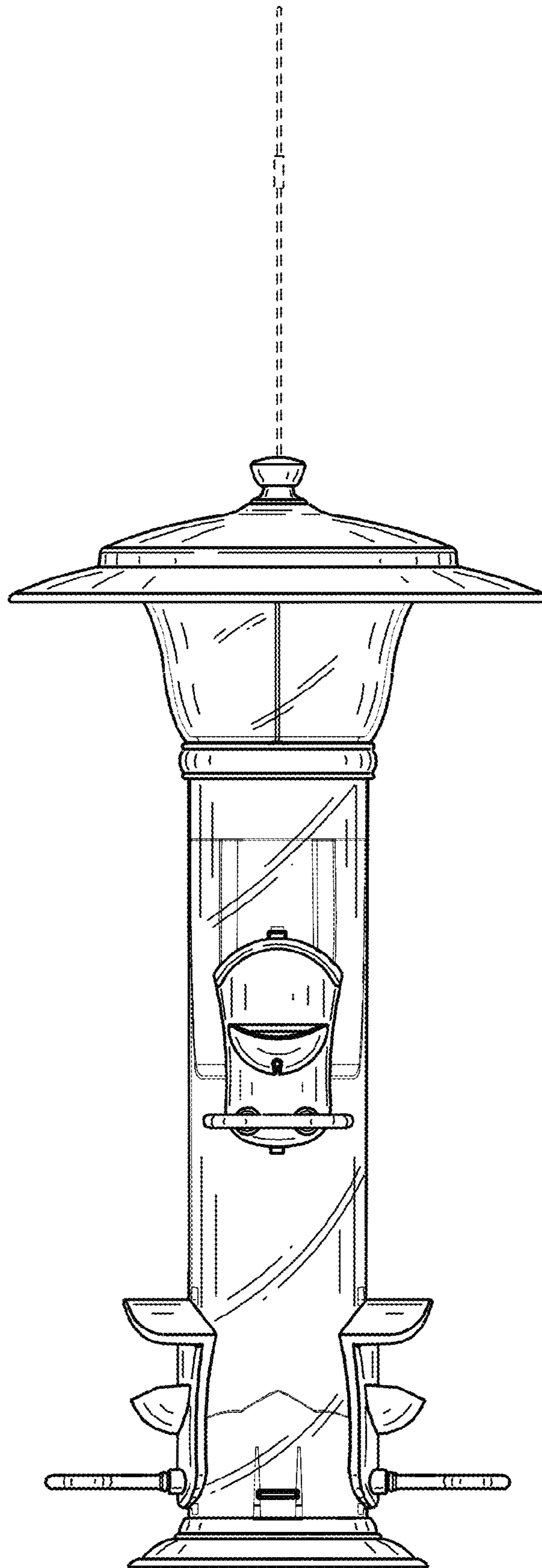

FIG. 3



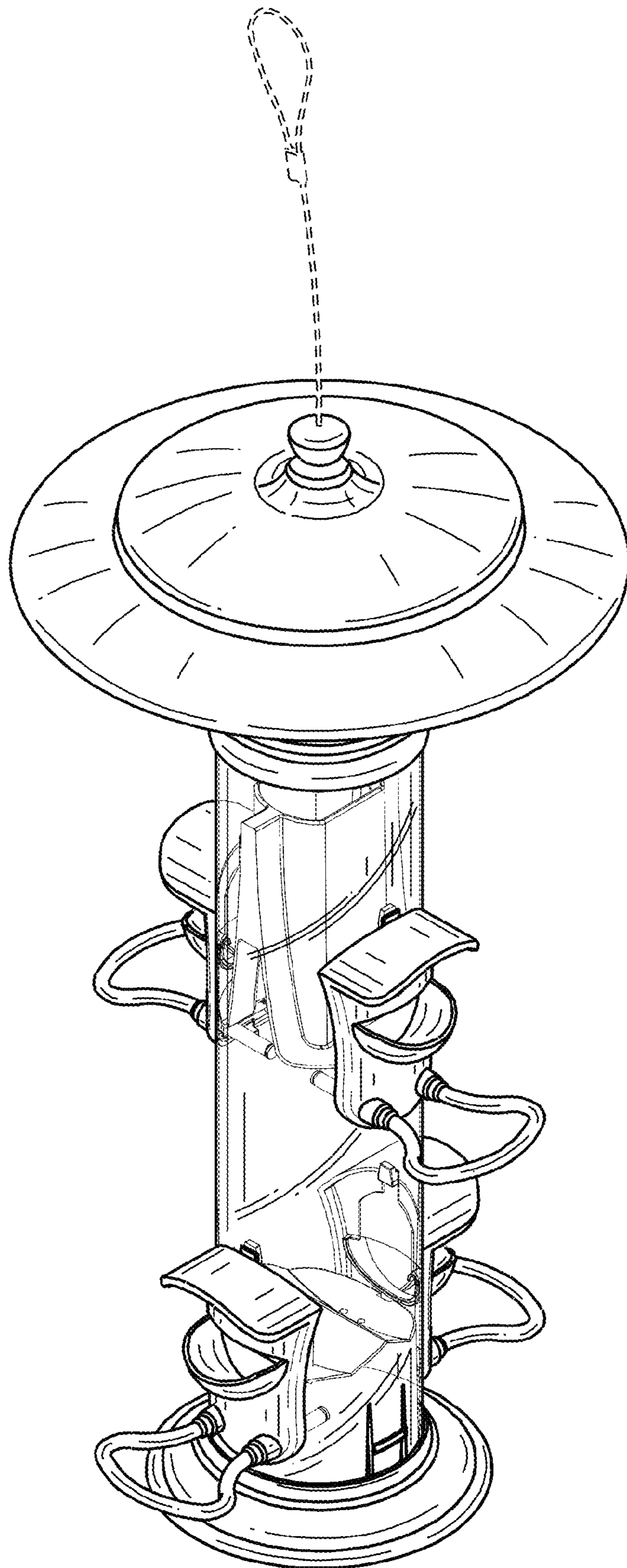

FIG. 4

FIG. 5

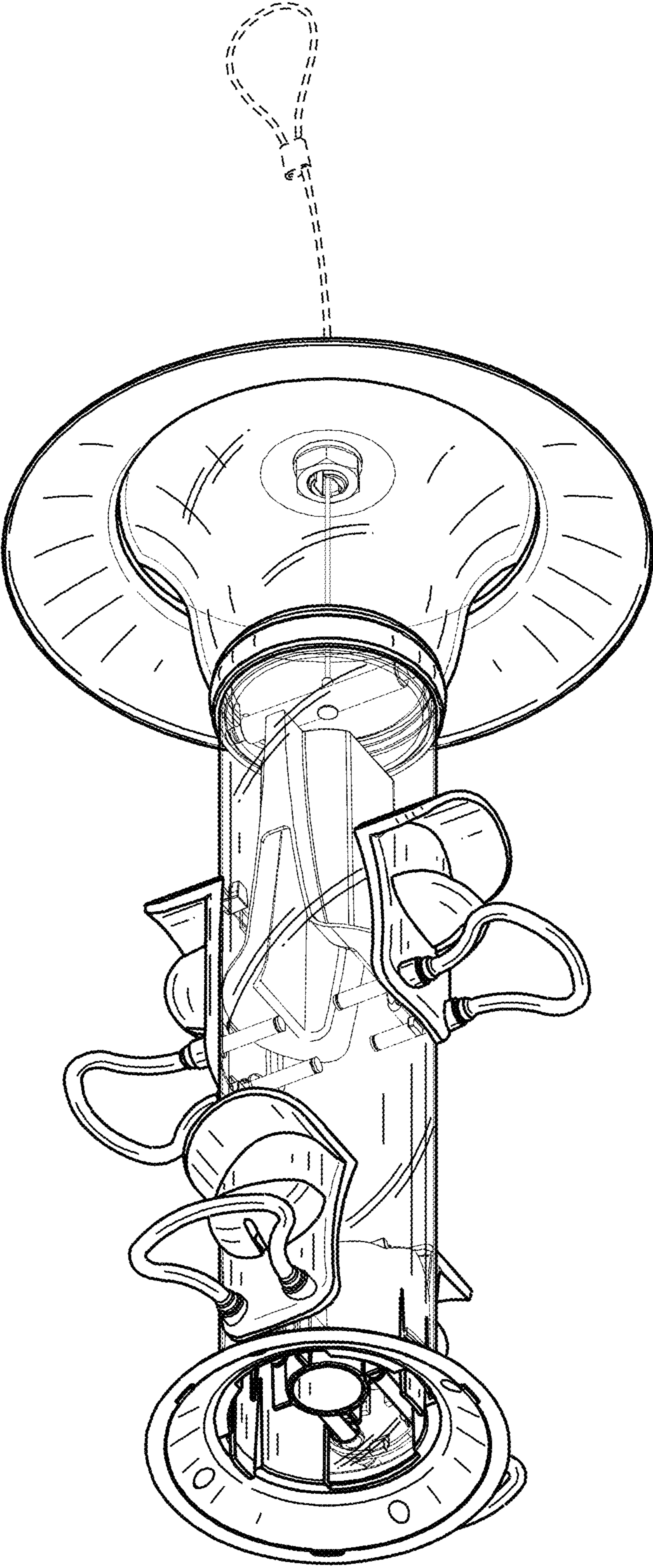
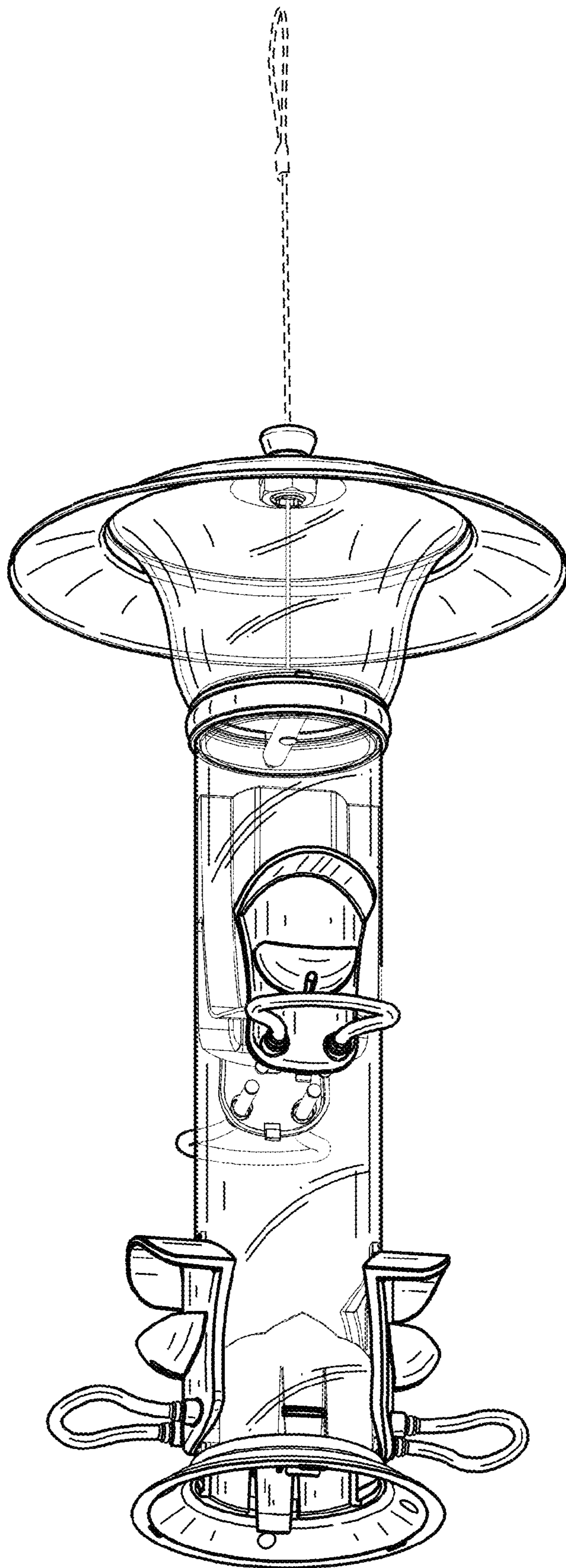

FIG. 6



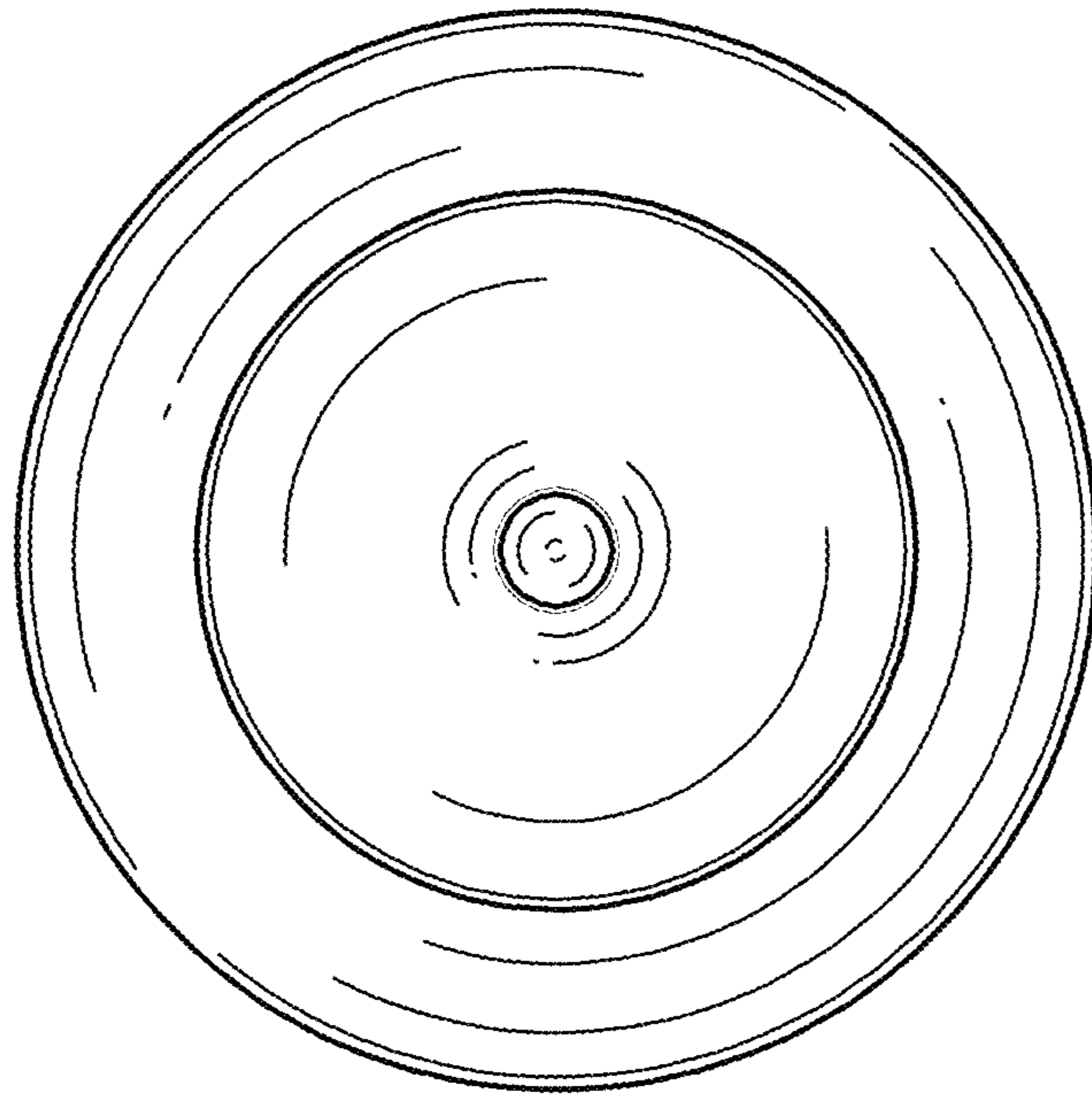

FIG. 7

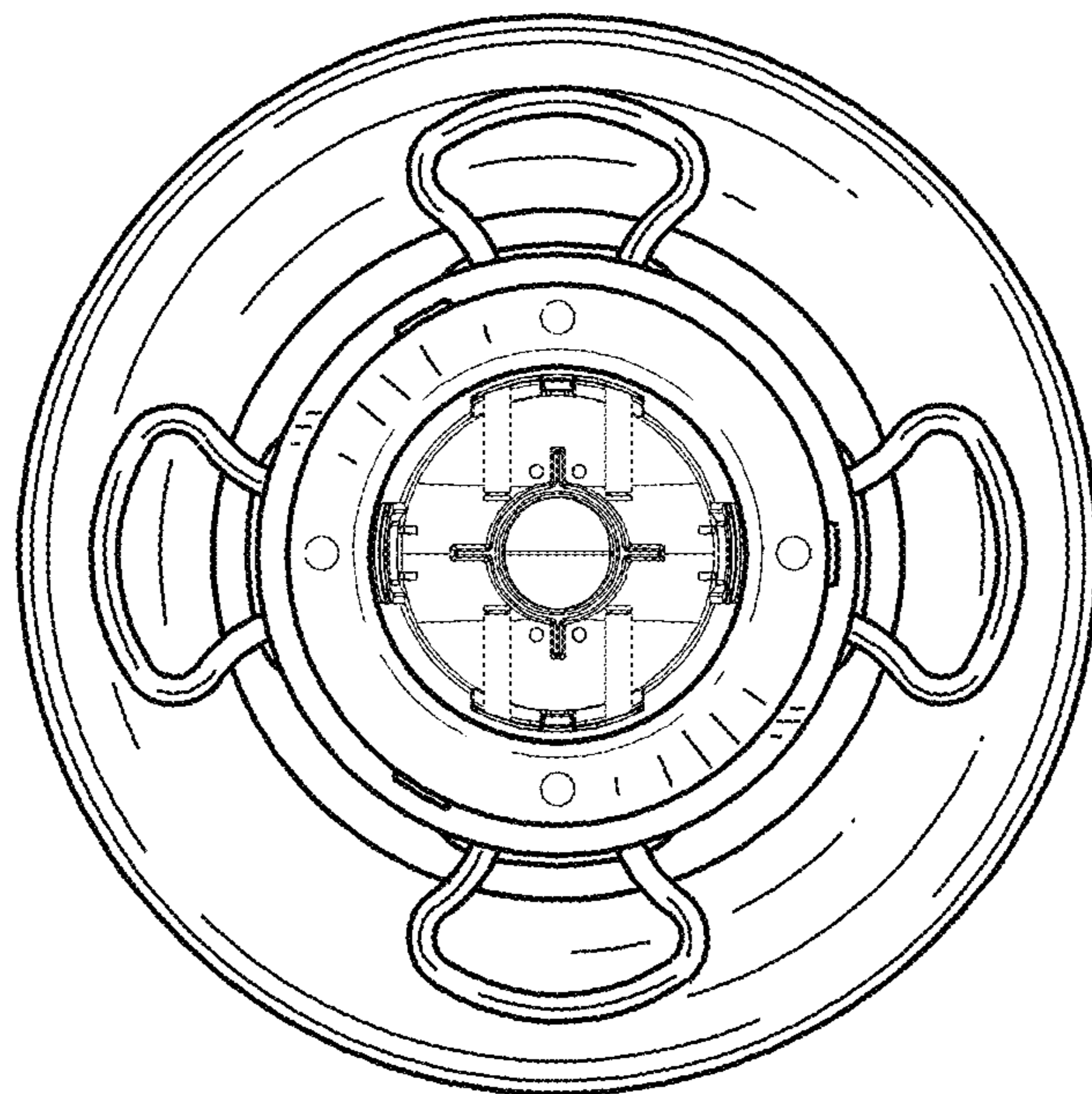

FIG. 8