



US00D723200S

(12) **United States Design Patent**  
**Shelton**

(10) **Patent No.:** **US D723,200 S**  
(45) **Date of Patent:** **\*\* Feb. 24, 2015**

(54) **VEHICLE BRAKE LIGHT AND TAIL LIGHT OVERLAY**

7,068,159 B2 6/2006 Ko  
D529,642 S \* 10/2006 Green ..... D26/31  
D590,969 S \* 4/2009 Mulla ..... D26/31

(71) Applicant: **James A. Shelton**, Columbus, MS (US)

\* cited by examiner

(72) Inventor: **James A. Shelton**, Columbus, MS (US)

*Primary Examiner* — Marcus Jackson

(\*\*) Term: **14 Years**

(74) *Attorney, Agent, or Firm* — Robert C. Montgomery;  
Montgomery Patent & Design

(21) Appl. No.: **29/447,168**

(57) **CLAIM**

The ornamental design for a vehicle brake light and tail light overlay, as shown and described.

(22) Filed: **Mar. 1, 2013**

(51) **LOC (10) Cl.** ..... **26-06**

(52) **U.S. Cl.**

USPC ..... **D26/31**

(58) **Field of Classification Search**

USPC ..... D26/28–36; 362/459–468, 475–478,  
362/485–487

See application file for complete search history.

**DESCRIPTION**

FIG. 1 is an environmental view of a brake light and a pair of tail lights with the overlay thereon;

FIG. 2 is an isometric view of the brake light with the overlay thereon;

FIG. 3 is an isometric view of the overlay;

FIG. 4 is a front view thereof, with the rear view being a mirror image thereof.;

FIG. 5 is a left hand side view thereof;

FIG. 6 is a right hand side view thereof;

FIG. 7 is a top view thereof;

FIG. 8 is a bottom view thereof;

FIG. 9 is an isometric view of a first tail light with the overlay thereon; and,

FIG. 10 is an isometric view of a second tail light with the overlay thereon.

(56) **References Cited**

U.S. PATENT DOCUMENTS

3,875,556	A	4/1975	Beaird	
4,849,733	A	7/1989	Conigliaro et al.	
5,714,930	A	2/1998	McKinney, Jr.	
5,877,707	A	3/1999	Kowalick	
6,059,066	A	5/2000	Lary	
6,545,597	B1	4/2003	Blount	
D483,891	S *	12/2003	Suberi	..... D26/31
6,774,781	B1	8/2004	Lee	
6,784,803	B1	8/2004	Hypke et al.	

**1 Claim, 8 Drawing Sheets**

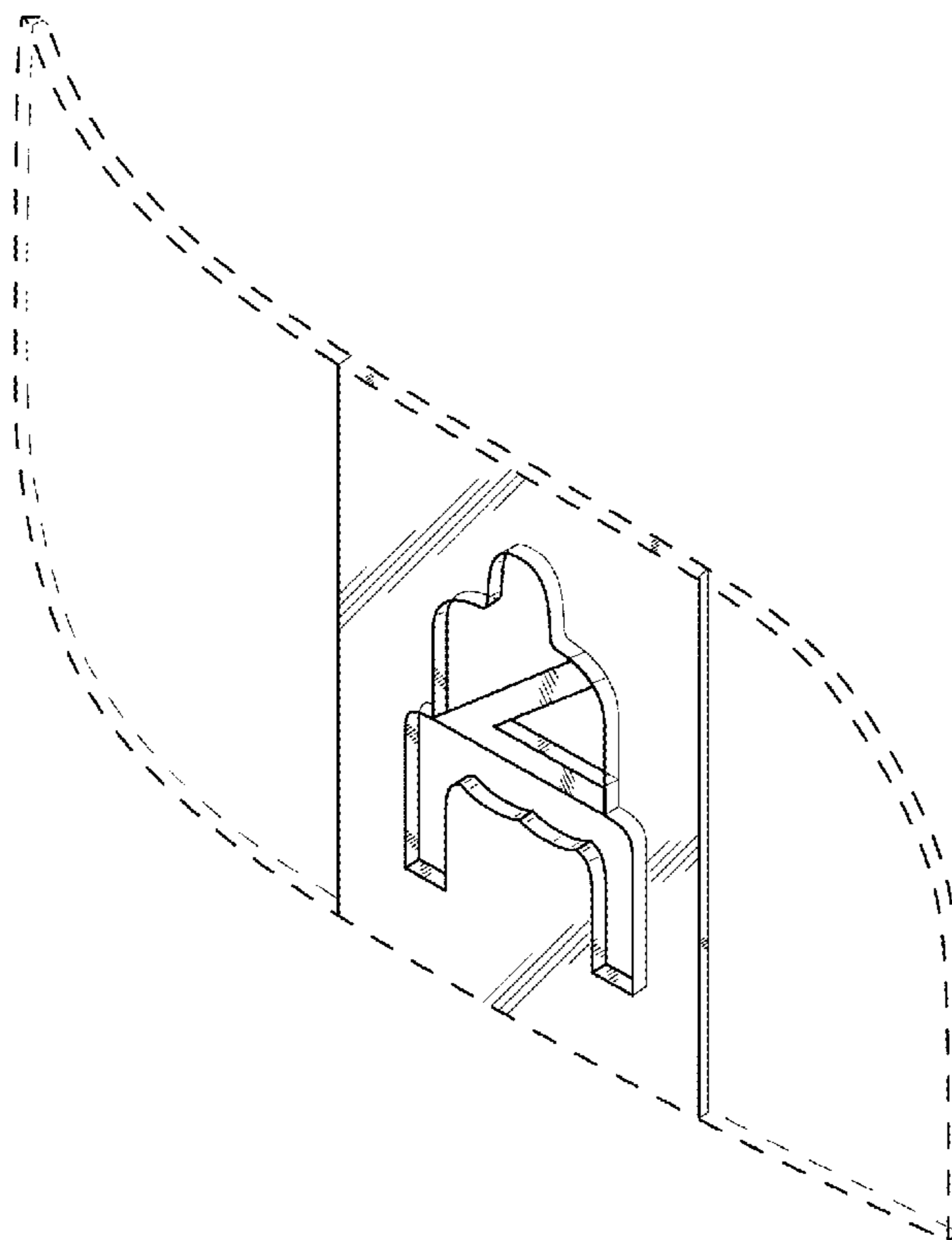

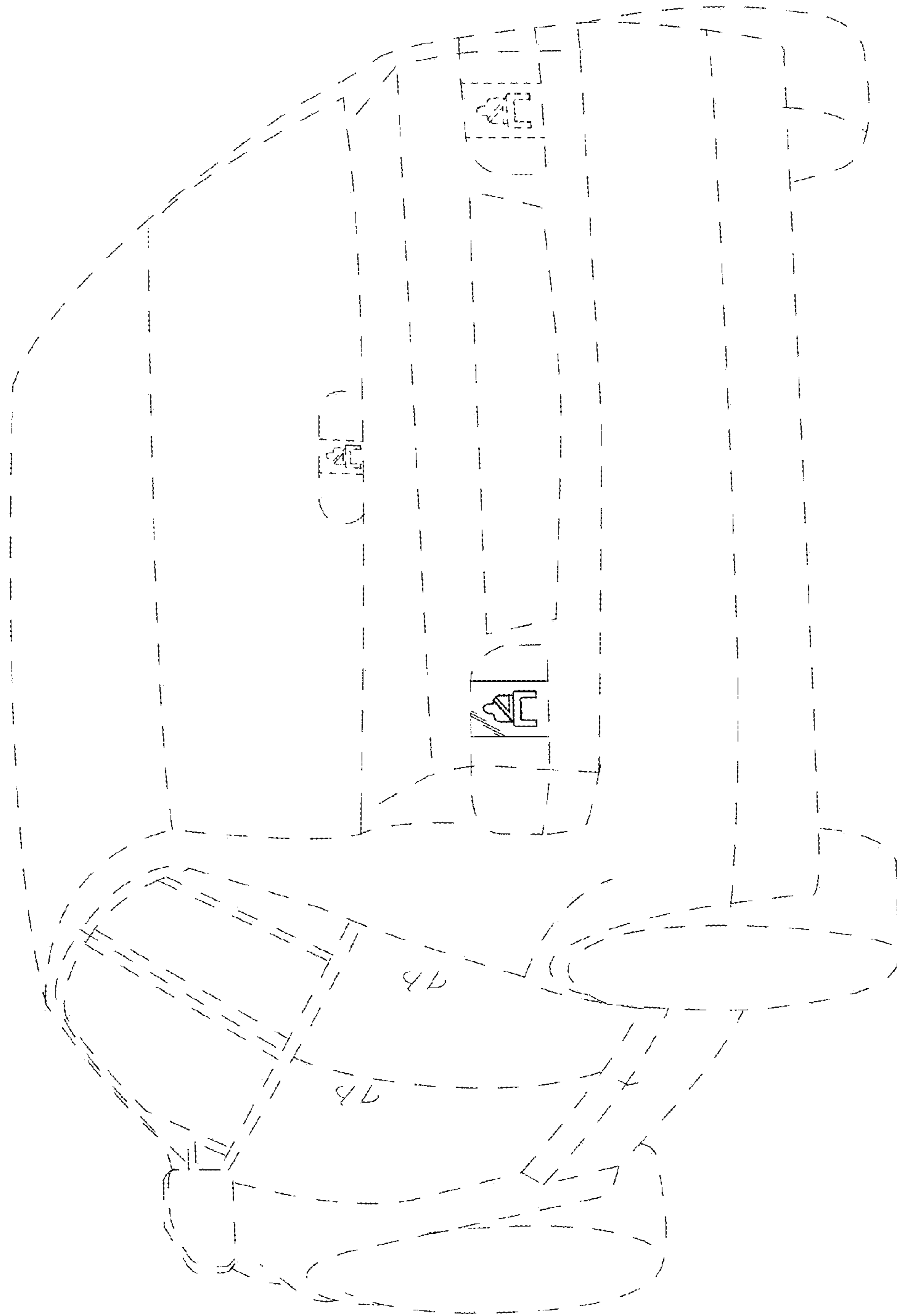

Fig. 1

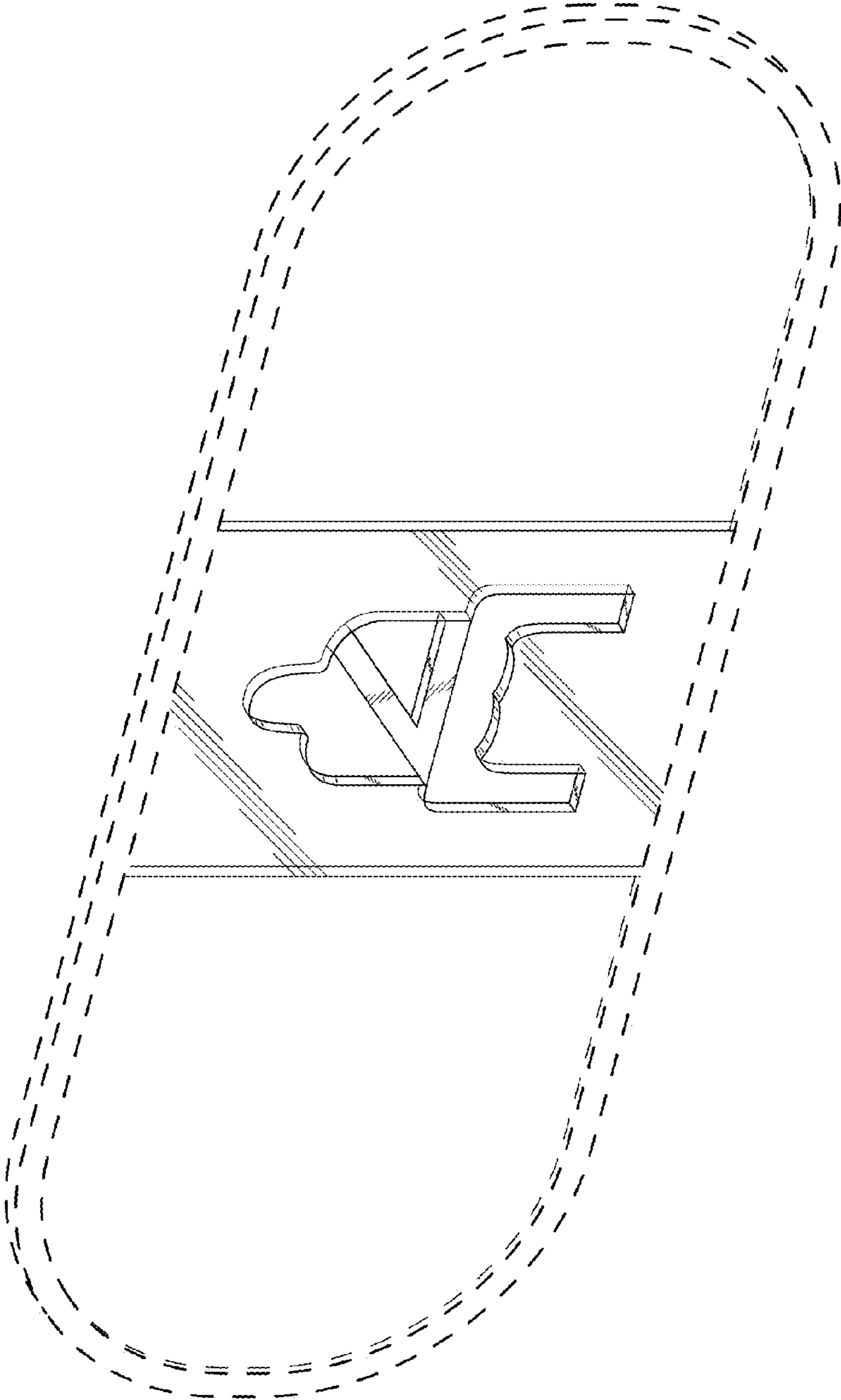

Fig. 2

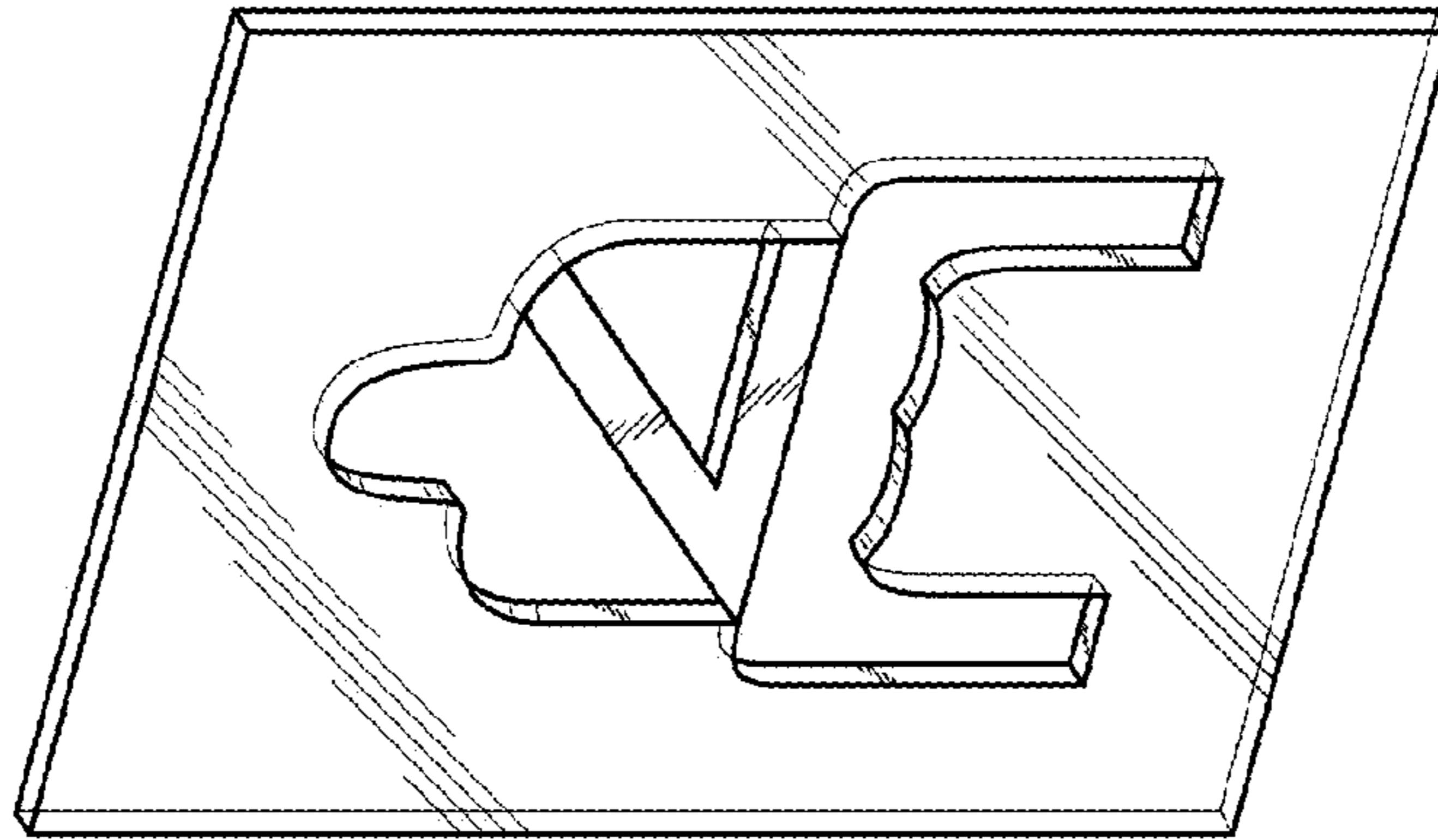

Fig. 3

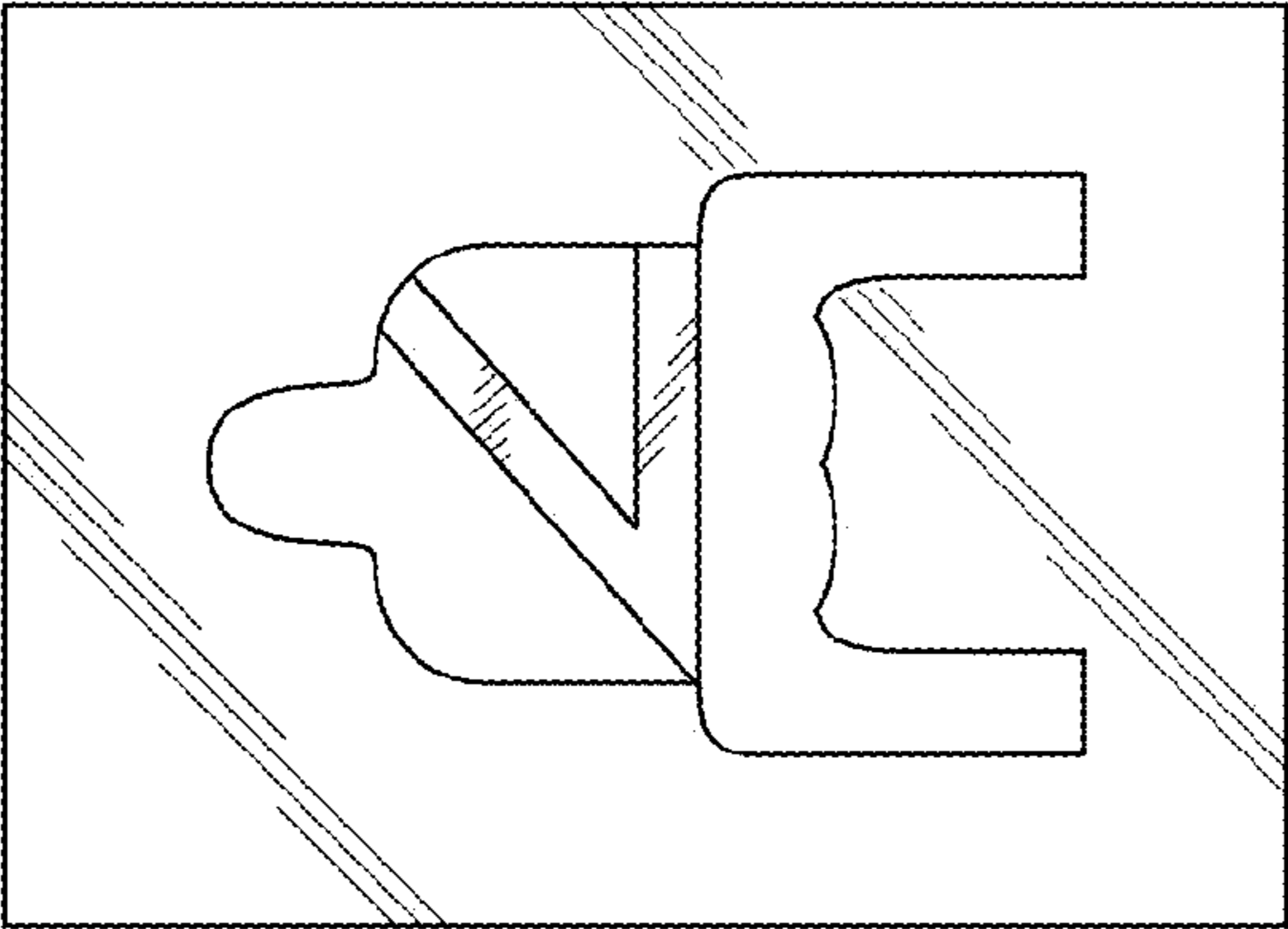

Fig. 4



Fig. 6

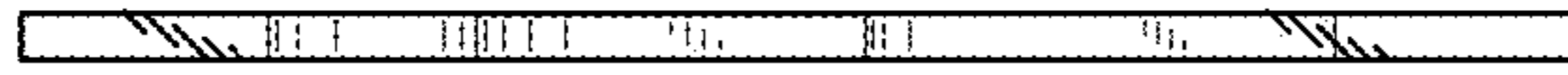

Fig. 5



Fig. 8



Fig. 7

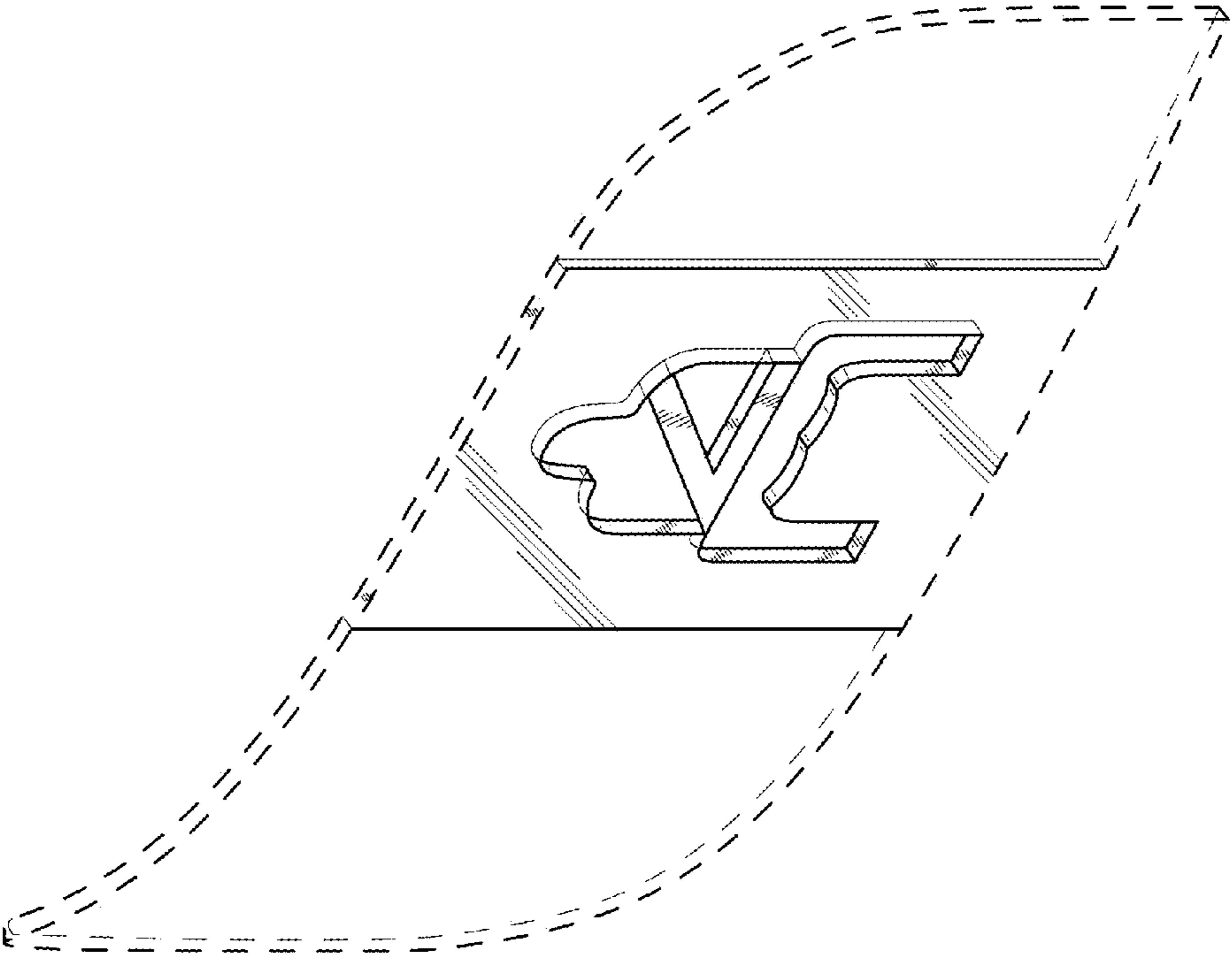

Fig. 9



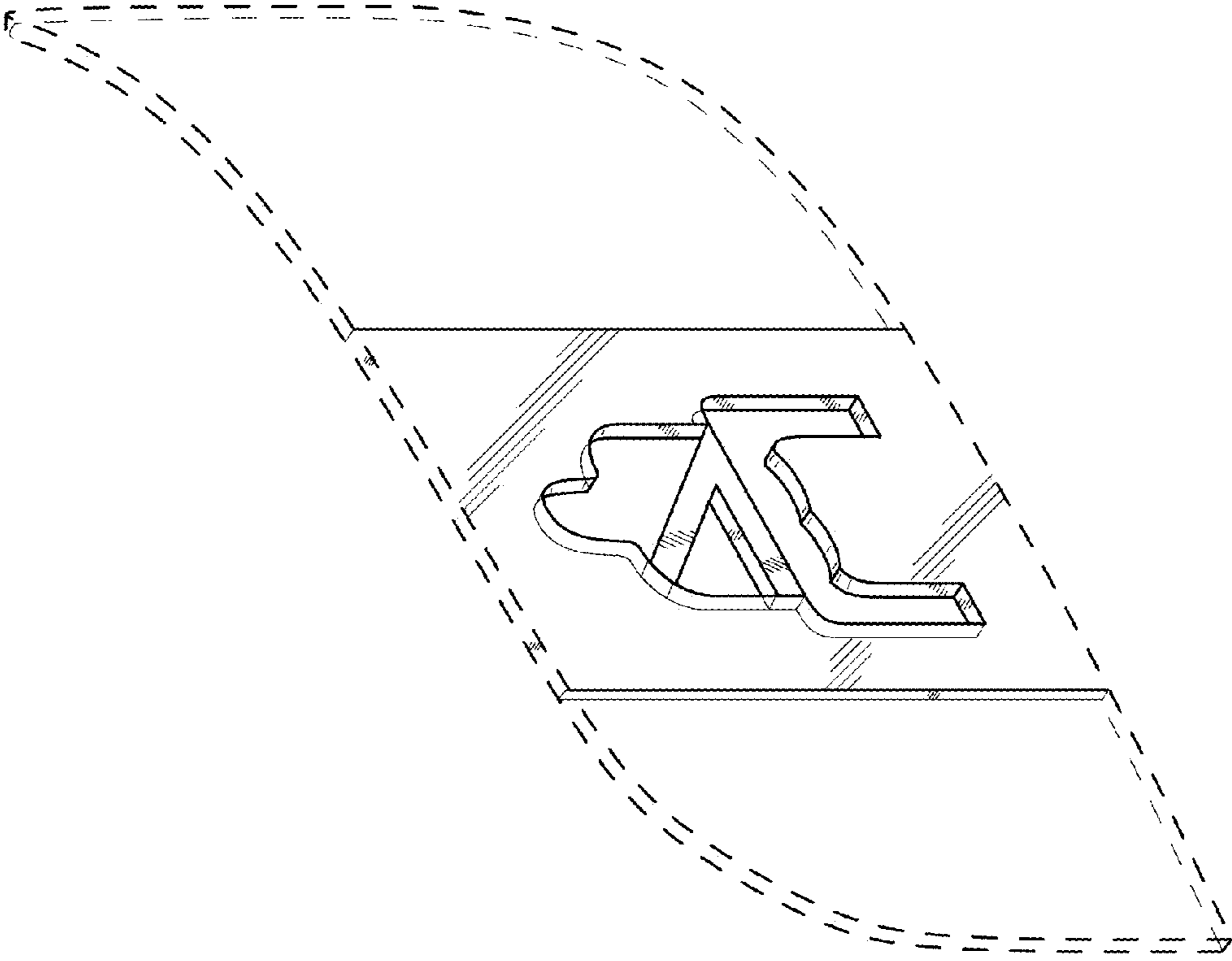

Fig. 10