



US00D722920S

(12) **United States Design Patent**
Minami et al.

(10) **Patent No.:** **US D722,920 S**
(45) **Date of Patent:** **** Feb. 24, 2015**

(54) **AUTOMOBILE**

(71) Applicant: **Honda Motor Co., Ltd.**, Tokyo (JP)

(72) Inventors: **Toshinobu Minami**, Wako (JP); **Jun Goto**, Wako (JP)

(73) Assignee: **Honda Motor Co., Ltd.**, Tokyo (JP)

(**) Term: **14 Years**

(21) Appl. No.: **29/477,646**

(22) Filed: **Dec. 24, 2013**

(30) **Foreign Application Priority Data**

Jun. 28, 2013 (JP) 2013-014747

(51) **LOC (10) Cl.** **12-08**

(52) **U.S. Cl.**
USPC **D12/92**

(58) **Field of Classification Search**
CPC B62D 35/00
USPC D12/86, 90-92; D21/421, 433, 434;
296/181.1, 181.5

See application file for complete search history.

(56) **References Cited**

U.S. PATENT DOCUMENTS

D667,343	S	*	9/2012	Fukui et al.	D12/92
D667,344	S	*	9/2012	Matsuno et al.	D12/92
D667,345	S	*	9/2012	Tanai et al.	D12/92
D667,756	S	*	9/2012	Asakura et al.	D12/92
D672,689	S	*	12/2012	Kubota et al.	D12/92
D684,898	S	*	6/2013	Minami	D12/92
D704,598	S	*	5/2014	Mueller	D12/92

* cited by examiner

Primary Examiner — Melody N Brown

(74) *Attorney, Agent, or Firm* — Westerman, Hattori, Daniels & Adrian, LLP

(57) **CLAIM**

The ornamental design for an automobile, as shown and described.

DESCRIPTION

FIG. 1 is a left front perspective view of an automobile showing our new design;
FIG. 2 is a right front perspective view thereof;
FIG. 3 is a front elevational view thereof, the rear elevational view being a mirror image thereof;
FIG. 4 is a left side elevational view thereof;
FIG. 5 is a right side elevational view thereof; and,
FIG. 6 is a top plan view thereof.
The broken lines illustrate environmental structure only and form no part of the claimed design.

1 Claim, 6 Drawing Sheets

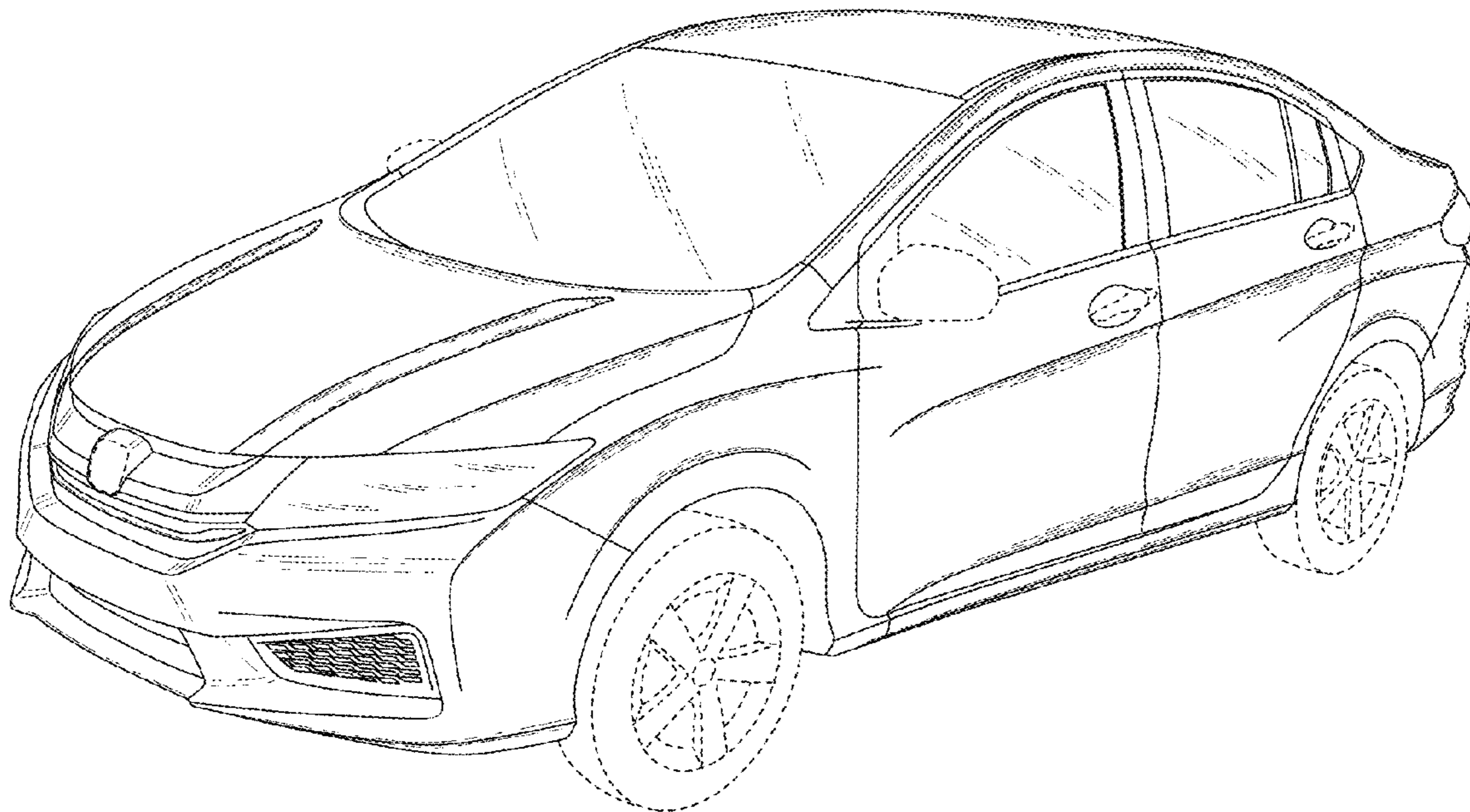

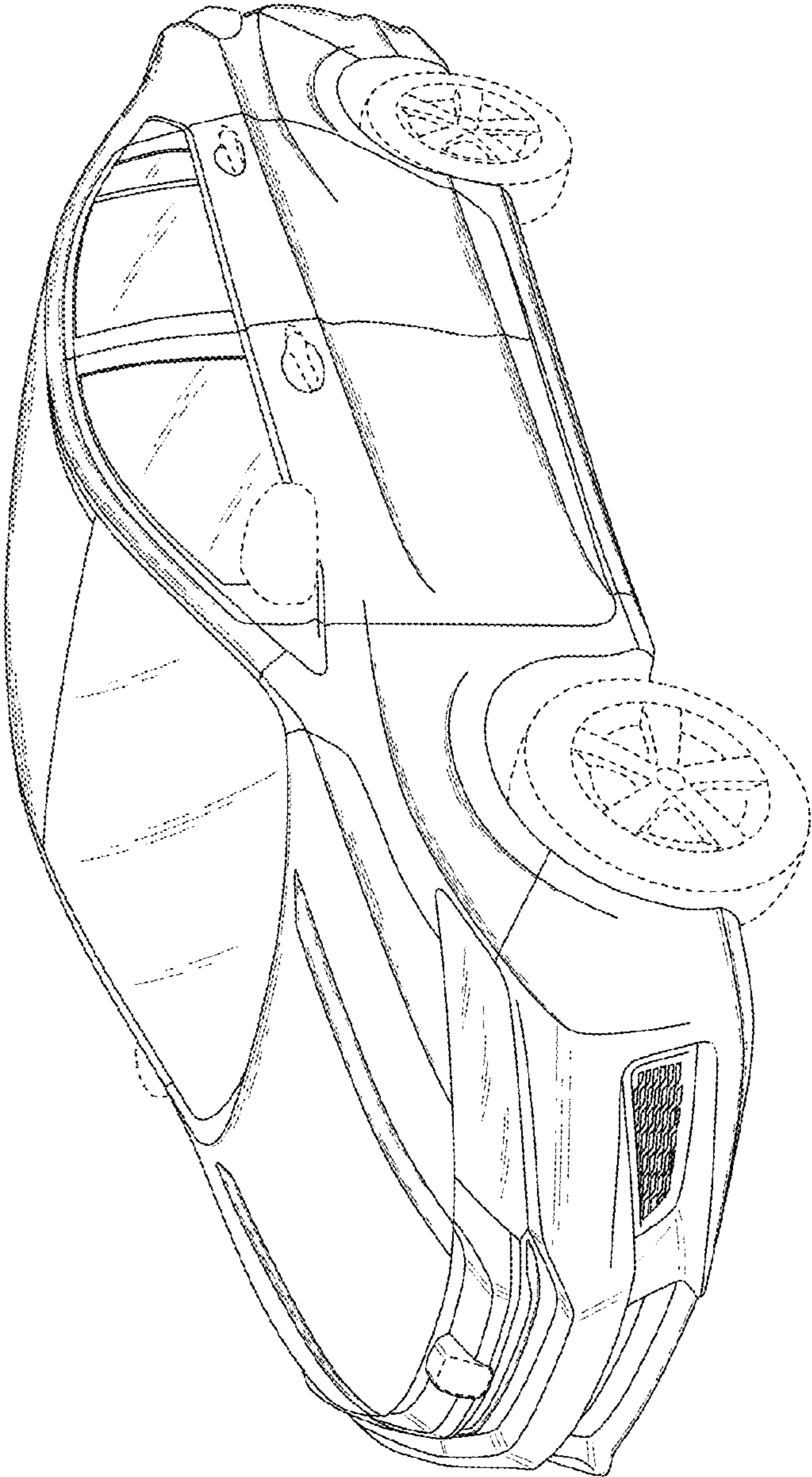

FIG.1

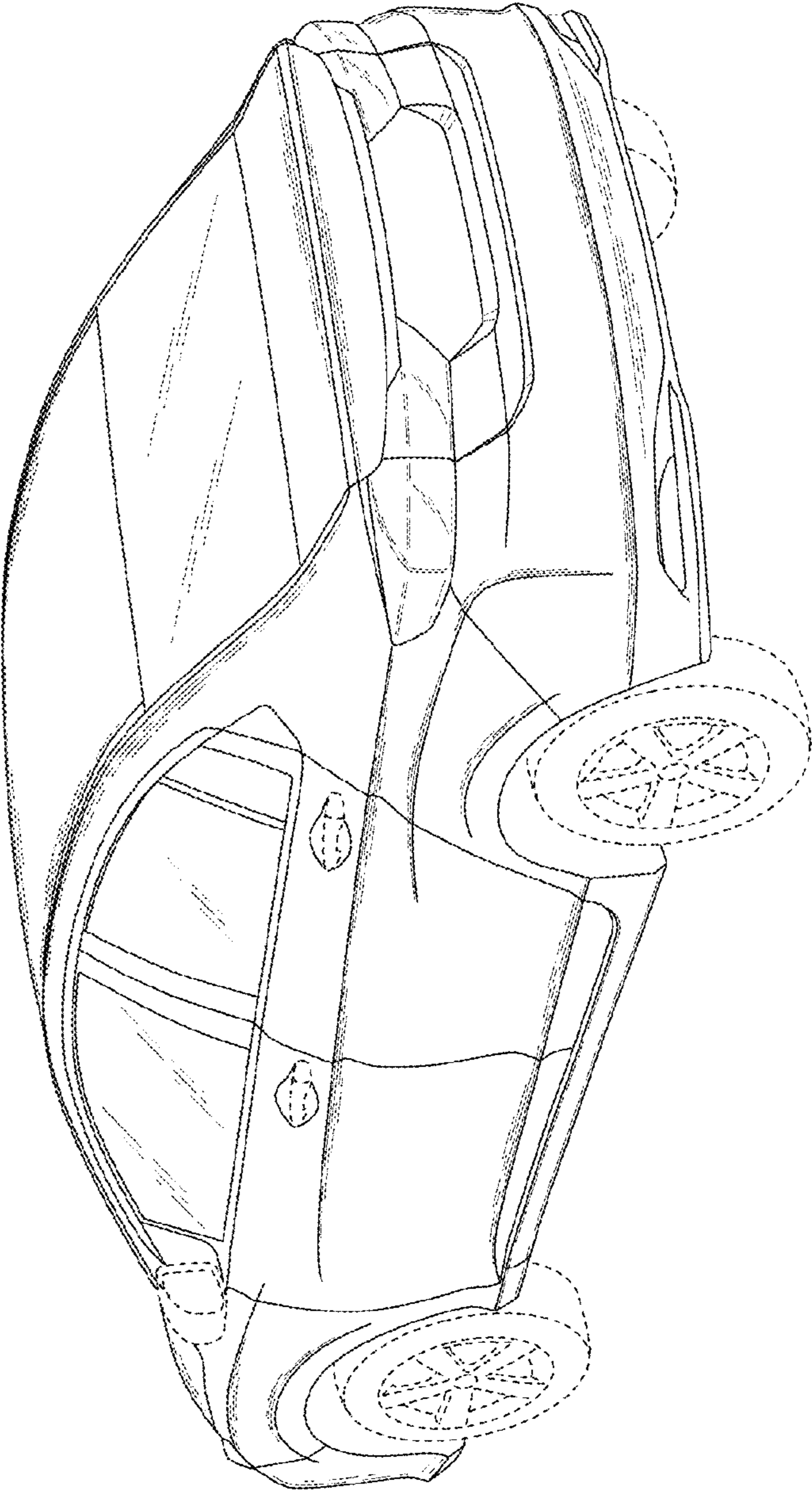

FIG.2

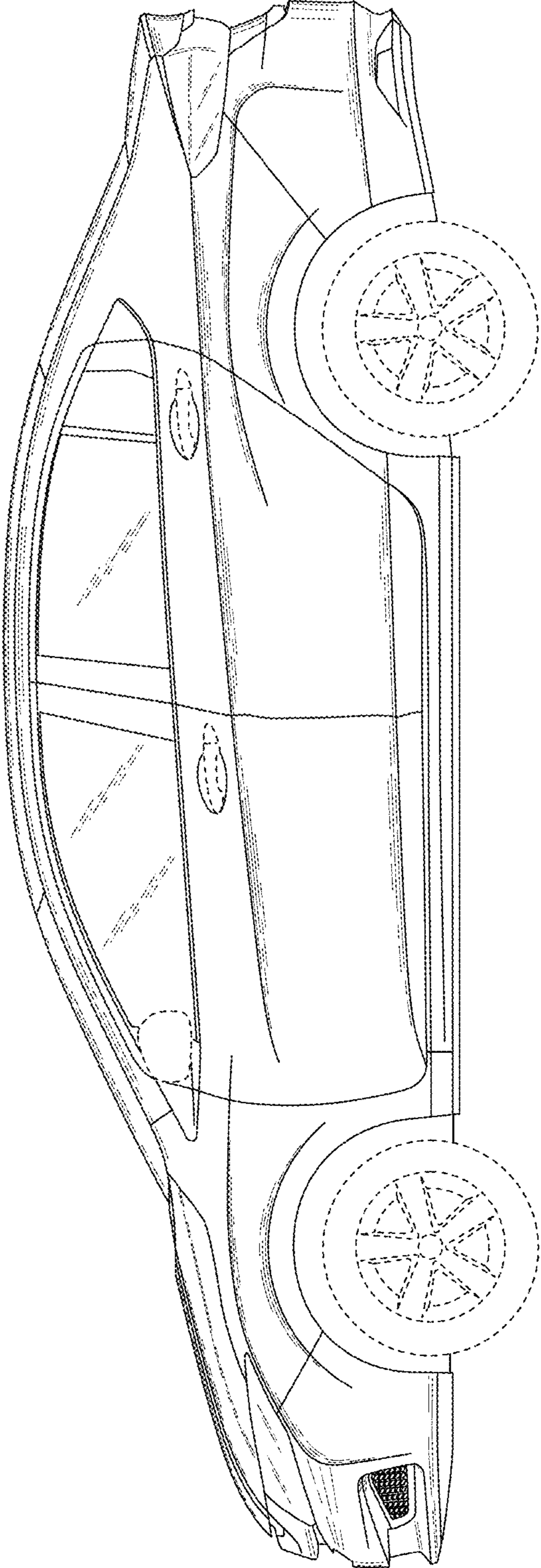

FIG.3

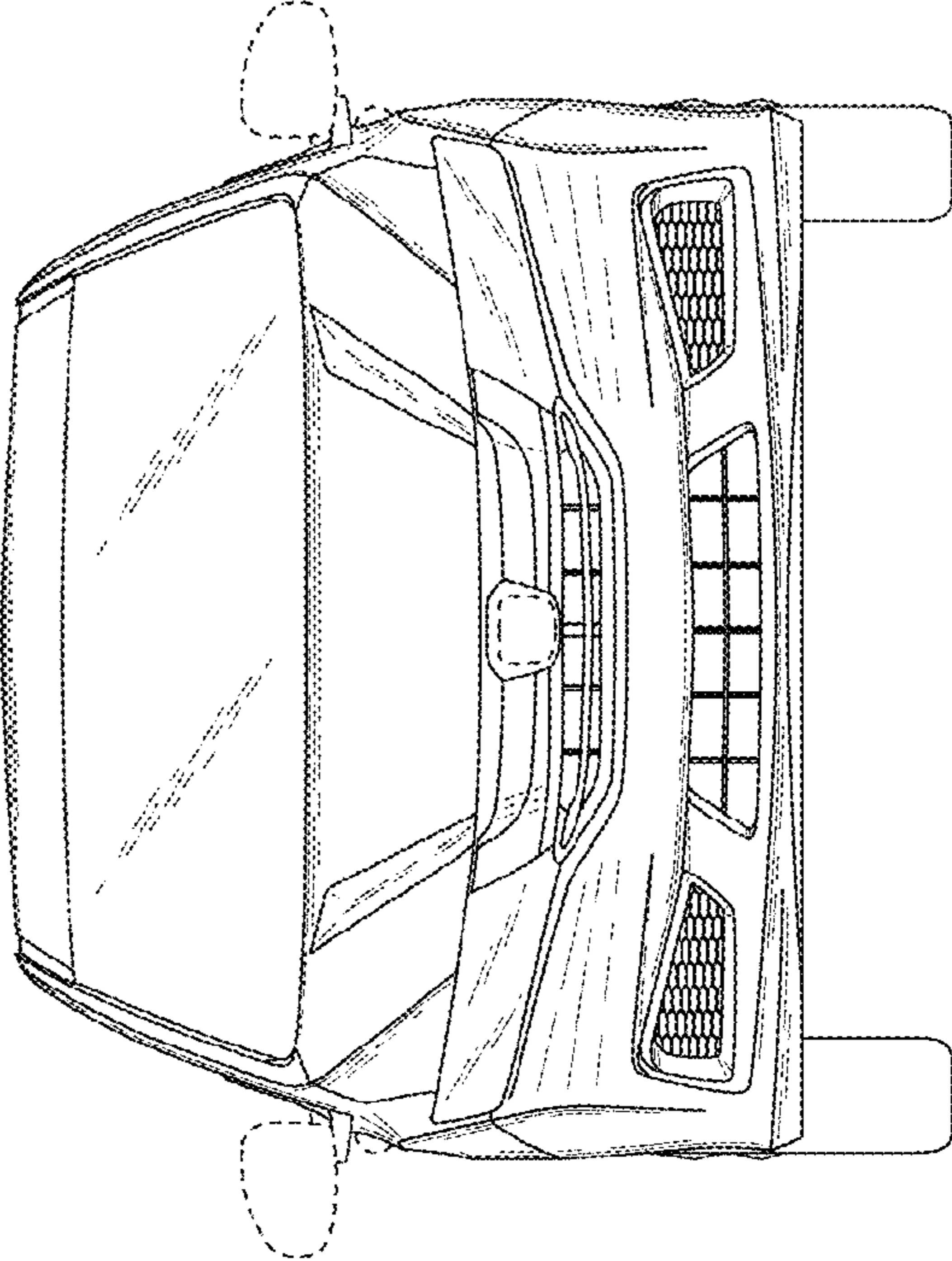

FIG.4

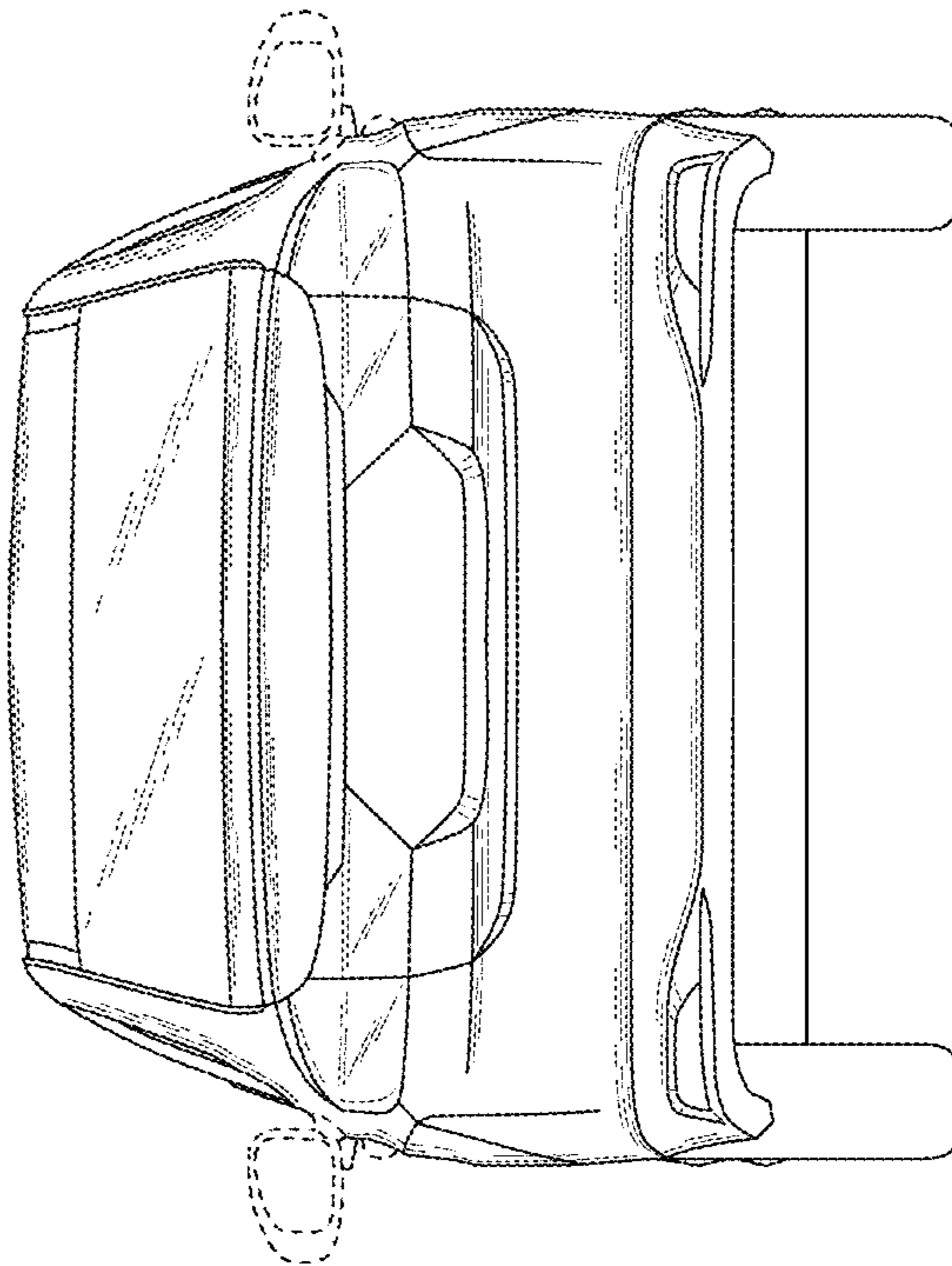

FIG.5

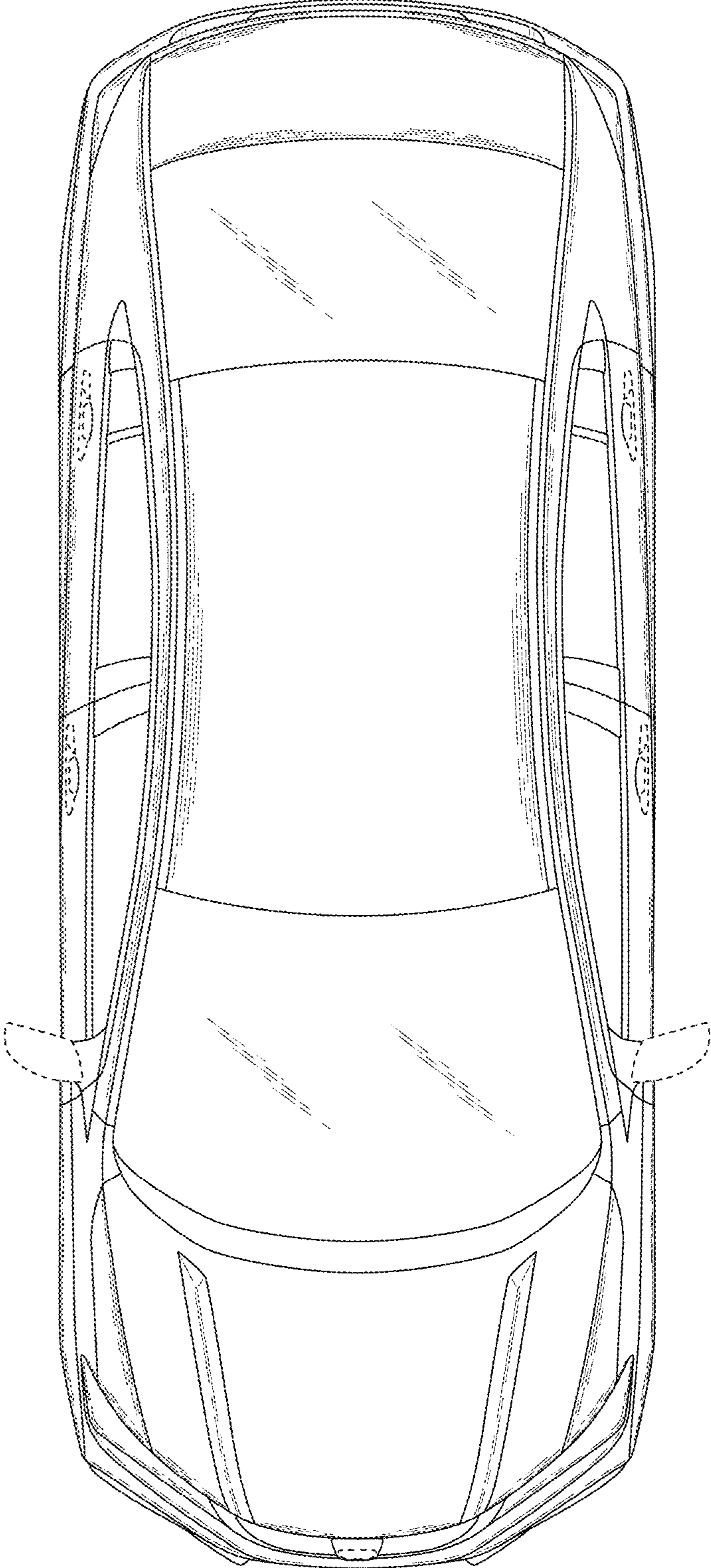

FIG.6