



US00D722878S

(12) **United States Design Patent**  
**Chivot et al.**

(10) **Patent No.:** **US D722,878 S**

(45) **Date of Patent:** **\*\* Feb. 24, 2015**

(54) **BOTTLE**

(71) Applicant: **PepsiCo, Inc.**, Purchase, NY (US)

(72) Inventors: **Emmanuel Chivot**, Poissy (FR); **Andy Jordan**, London (GB); **Philip Nigel Bordet-Stead**, London (GB); **Laurent Robin-Prevallee**, London (GB)

(73) Assignee: **PepsiCo, Inc.**, Purchase, NY (US)

(\*\*) Term: **14 Years**

(21) Appl. No.: **29/470,786**

(22) Filed: **Oct. 24, 2013**

(51) **LOC (10) Cl.** ..... **09-01**

(52) **U.S. Cl.**  
USPC ..... **D9/516; D9/549; D9/554; D9/559;**  
**D9/538**

(58) **Field of Classification Search**

CPC ..... B65D 1/0002; B65D 1/0223; B65D 1/40;  
B65D 1/42; B65D 23/00; B65D 2501/00;  
B65D 2501/0009

USPC ..... D9/516, 530, 537-538, 541, 549, 552,  
D9/554, 558-559, 567, 571, 600, 636, 640,  
D9/643-645, 648, 655, 657-661, 667;  
215/379, 381-382; 220/660, 669, 675

See application file for complete search history.

(56) **References Cited**

U.S. PATENT DOCUMENTS

D183,310 S *	8/1958	Hack .....	D9/657
D207,799 S *	5/1967	Roberts .....	D9/571
D286,984 S *	12/1986	Durand .....	D9/565
D478,278 S *	8/2003	Masotta et al. ....	D9/530
D524,165 S *	7/2006	Scott .....	D9/667
D571,213 S *	6/2008	Le Bras-Brown et al. ....	D9/516
D703,056 S *	4/2014	Yourist .....	D9/516
2011/0226788 A1 *	9/2011	Yourist .....	220/669

\* cited by examiner

*Primary Examiner* — Ian Simmons

*Assistant Examiner* — Dana L Meyrow

(74) *Attorney, Agent, or Firm* — Banner & Witcoff, Ltd.

(57) **CLAIM**

The ornamental design for a bottle, as shown and described.

**DESCRIPTION**

FIG. 1 is a top, front, right side perspective view of a bottle showing our new design;

FIG. 2 is a front elevation view thereof;

FIG. 3 is a right side elevation view thereof;

FIG. 4 is a rear elevation view thereof;

FIG. 5 is a left side elevation view thereof;

FIG. 6 is a top plan view thereof; and,

FIG. 7 is a bottom plan view thereof.

The evenly dashed broken lines in the drawings illustrate the portions of the design that form no part of the claim. The dot-dash broken lines in the drawings define the bounds of the claim and form no part thereof.

**1 Claim, 4 Drawing Sheets**

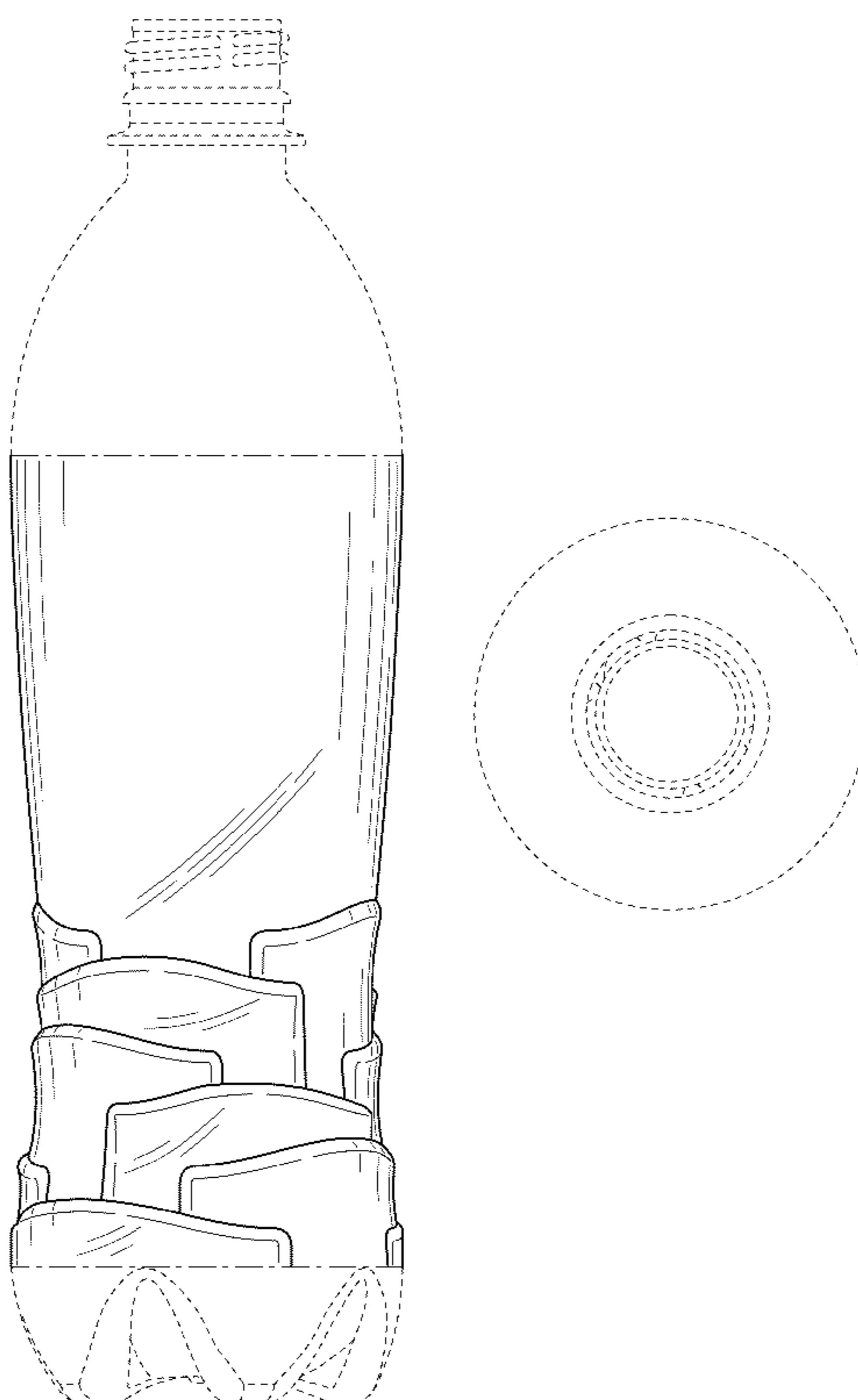

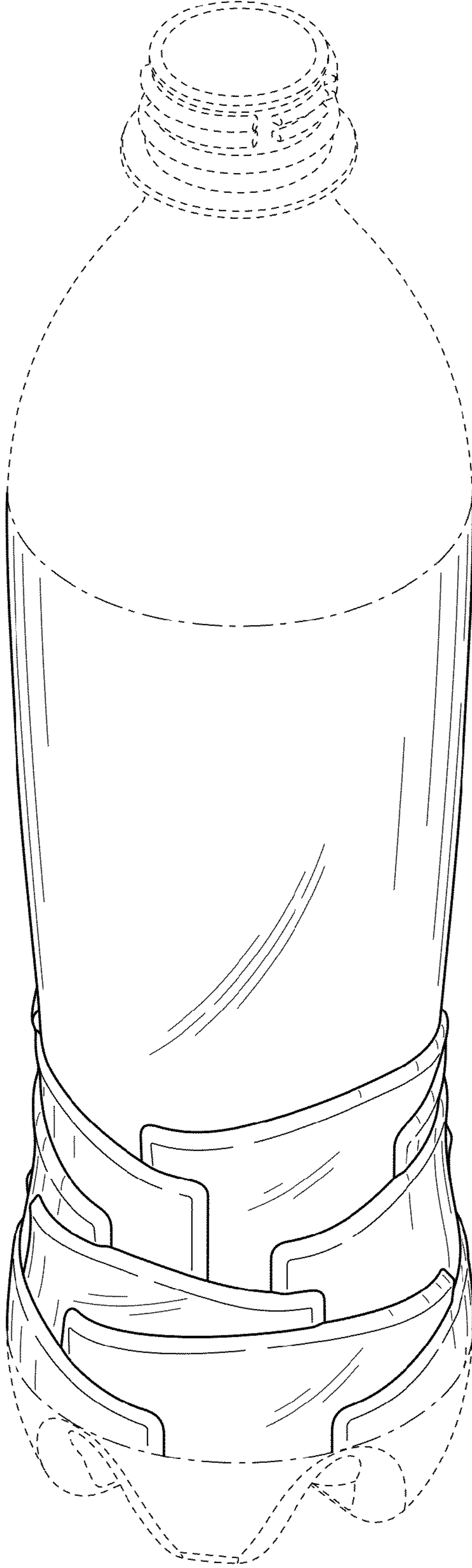

FIG. 1

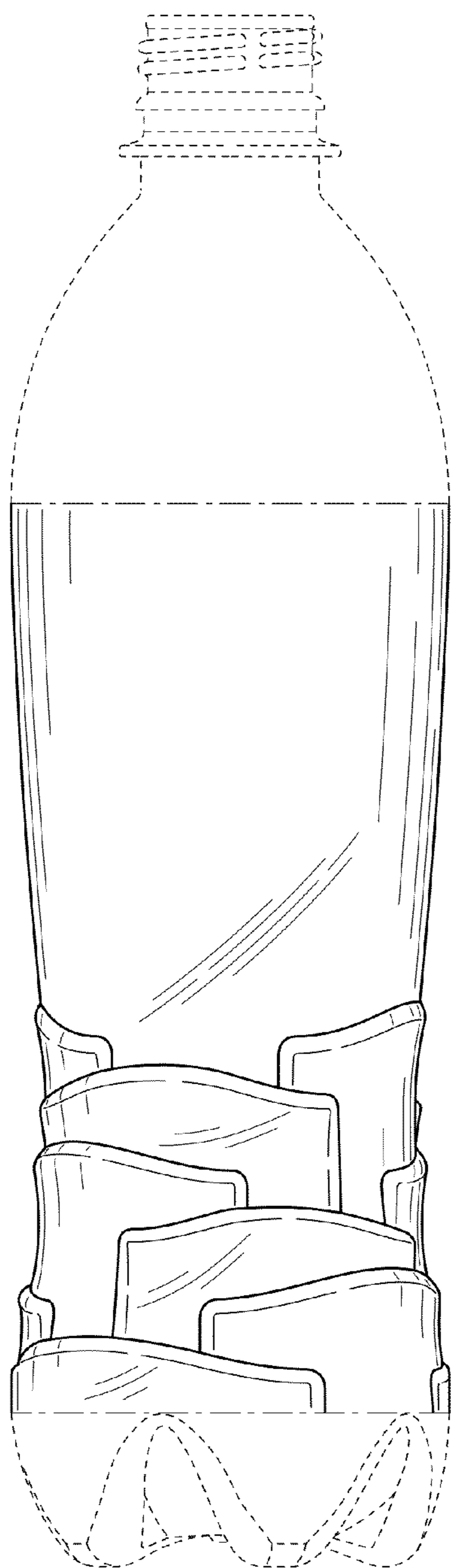

FIG. 2



FIG. 3

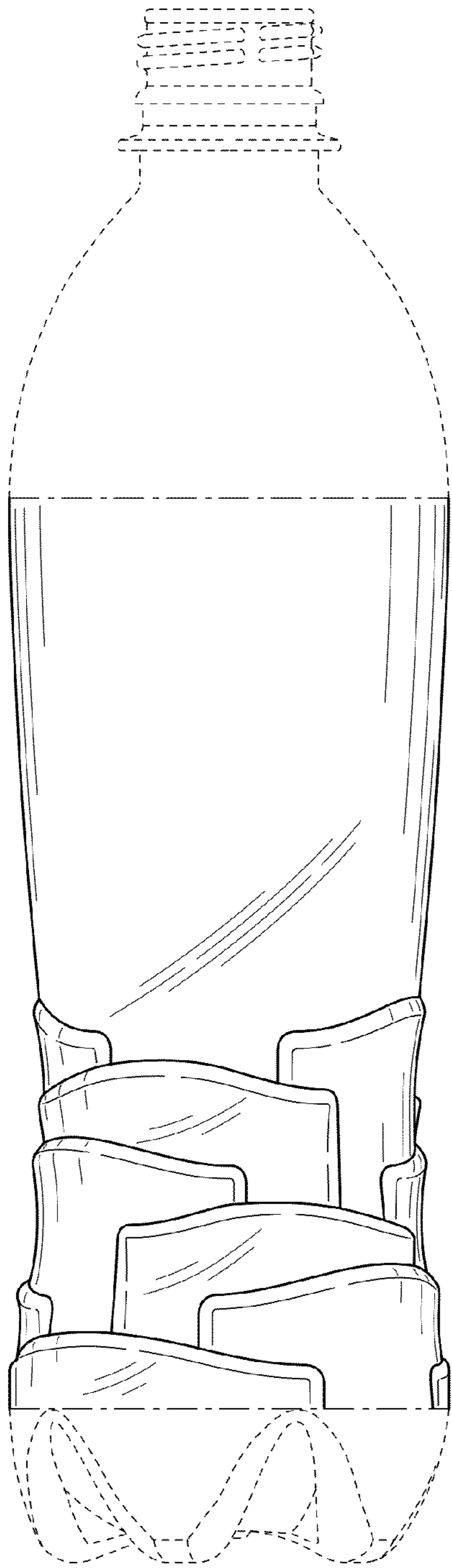
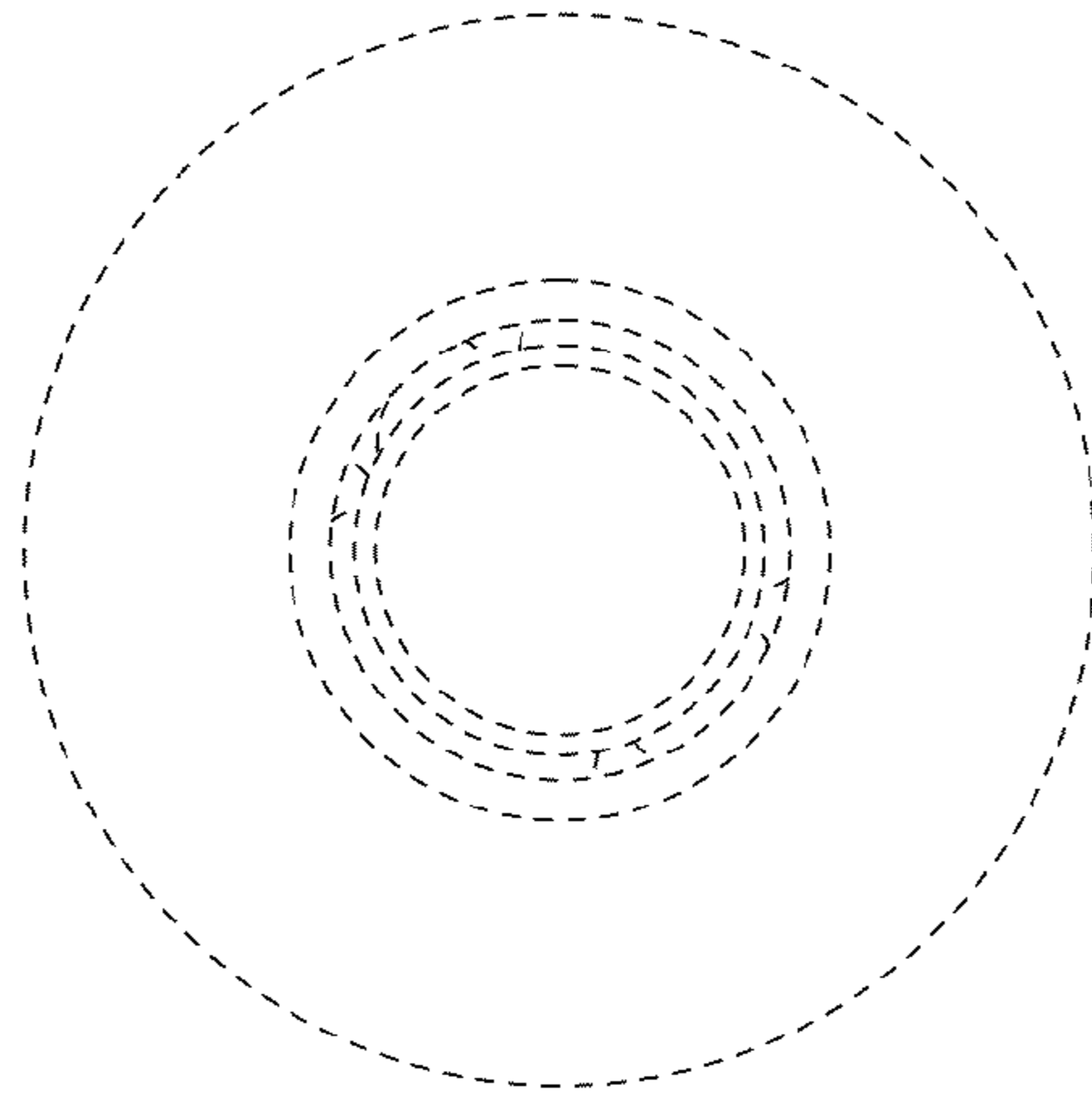

FIG. 4



FIG. 5



**FIG. 6**

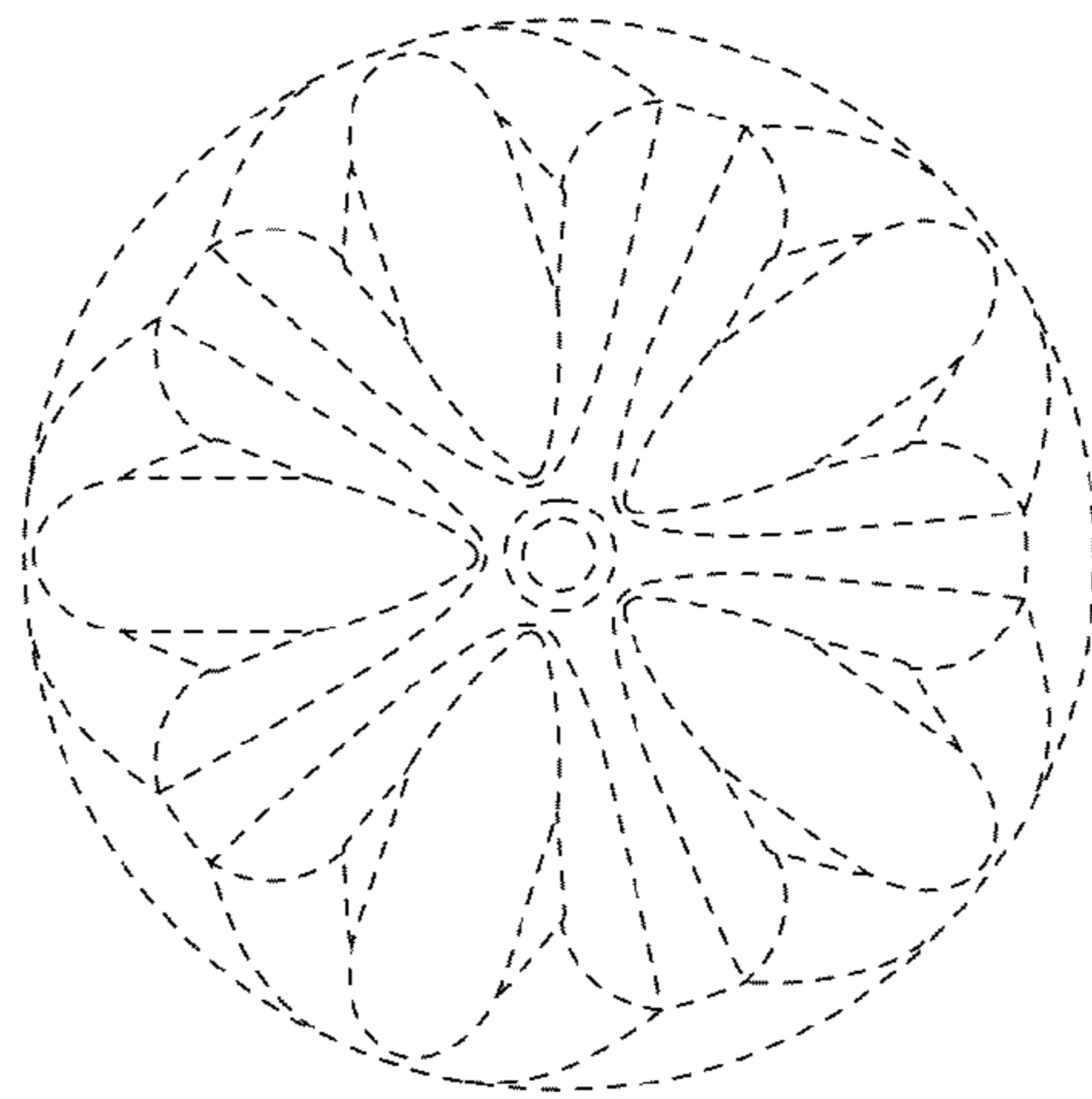

**FIG. 7**