



US00D722617S

(12) **United States Design Patent**  
**Sasaki**

(10) **Patent No.:** **US D722,617 S**

(45) **Date of Patent:** **\*\* Feb. 17, 2015**

(54) **CYLINDER BLOCK FOR INTERNAL COMBUSTION ENGINES**

(71) Applicant: **Honda Motor Co., Ltd.**, Tokyo (JP)

(72) Inventor: **Hideaki Sasaki**, Wako (JP)

(73) Assignee: **Honda Motor Co., Ltd.**, Tokyo (JP)

(\*\*) Term: **14 Years**

(21) Appl. No.: **29/483,920**

(22) Filed: **Mar. 4, 2014**

(30) **Foreign Application Priority Data**

Sep. 4, 2013 (JP) ..... 2013-020454

(51) **LOC (10) Cl.** ..... **15-01**

(52) **U.S. Cl.**  
USPC ..... **D15/5**

(58) **Field of Classification Search**  
USPC ..... D15/1-5; 123/193.2, 195 R, 196 R,  
123/41.84, 41.74, 41.79  
See application file for complete search history.

(56) **References Cited**

**U.S. PATENT DOCUMENTS**

4,515,112	A *	5/1985	Tsuchiya et al.	123/41.84
4,683,844	A *	8/1987	Arai et al.	123/41.74
4,712,517	A *	12/1987	Anno et al.	123/41.74
4,757,790	A *	7/1988	Ushio et al.	123/193.2
4,846,116	A *	7/1989	Sakurahara et al.	123/41.74
4,856,462	A *	8/1989	Ushio et al.	123/41.84
4,993,378	A *	2/1991	Sakurahara et al.	123/196 R
5,291,862	A *	3/1994	Katoh et al.	123/193.2
5,357,921	A *	10/1994	Katoh et al.	123/193.2
5,462,108	A *	10/1995	Katoh et al.	164/98

5,537,969	A *	7/1996	Hata et al.	123/193.2
6,125,811	A *	10/2000	Koriyama et al.	123/195 R
6,543,334	B2 *	4/2003	Yamauchi	92/140
7,069,882	B2 *	7/2006	Yonezawa et al.	123/41.72
D649,978	S *	12/2011	Aketa et al.	D15/5
8,312,848	B2 *	11/2012	Weed	123/41.79
D704,742	S *	5/2014	Asano et al.	D15/5
D704,744	S *	5/2014	Shuto et al.	D15/5
2007/0143996	A1 *	6/2007	Michioka	29/888.06

\* cited by examiner

*Primary Examiner* — T. Chase Nelson

*Assistant Examiner* — Ania Aman

(74) *Attorney, Agent, or Firm* — Westerman, Hattori, Daniels & Adrian, LLP

(57) **CLAIM**

The ornamental design for a cylinder block for internal combustion engines, as shown and described.

**DESCRIPTION**

FIG. 1 is a front view of the cylinder block for internal combustion engines according to my new invention;  
 FIG. 2 is a rear view thereof;  
 FIG. 3 is a top plan view thereof;  
 FIG. 4 is a bottom plan view thereof;  
 FIG. 5 is a right side elevational view thereof;  
 FIG. 6 is a left side elevational view thereof;  
 FIG. 7 is a front perspective view thereof, as seen from the upper right side;  
 FIG. 8 is a front perspective view thereof, as seen from the lower right side;  
 FIG. 9 is a rear perspective view thereof, as seen from the upper left side; and,  
 FIG. 10 is a rear perspective view thereof, as seen from the lower left side.

**1 Claim, 10 Drawing Sheets**

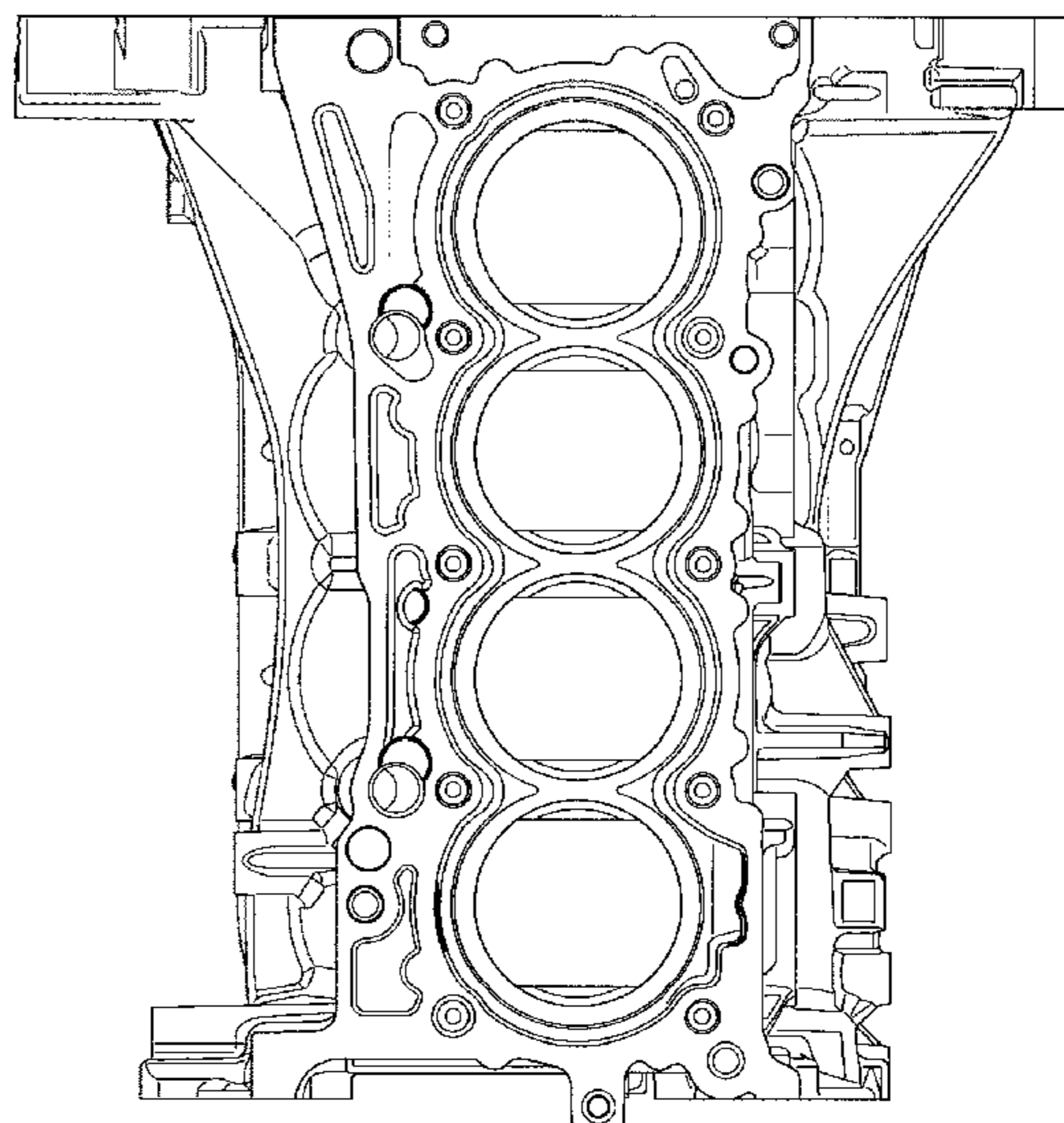

FIG. 1

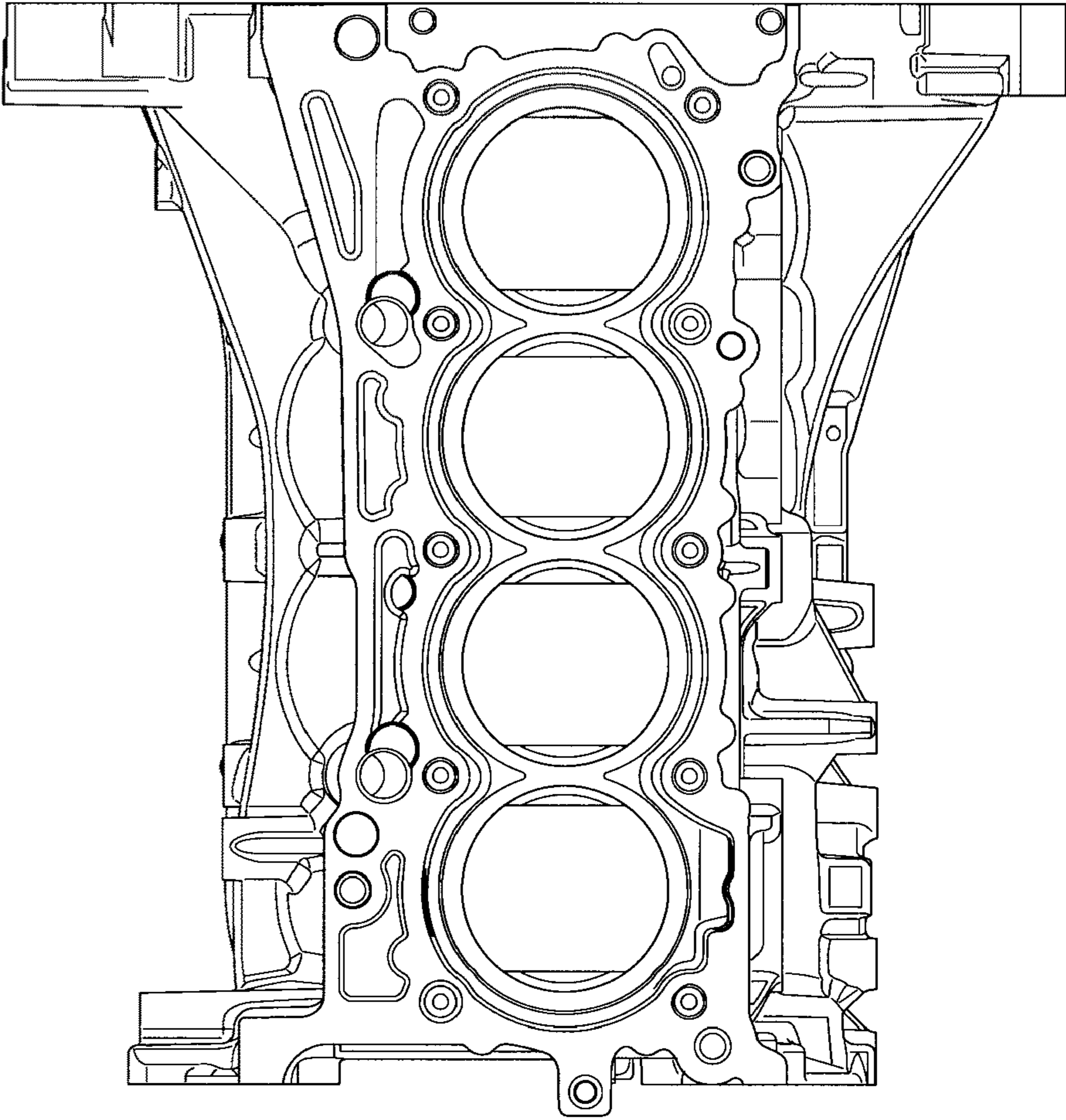

FIG.2

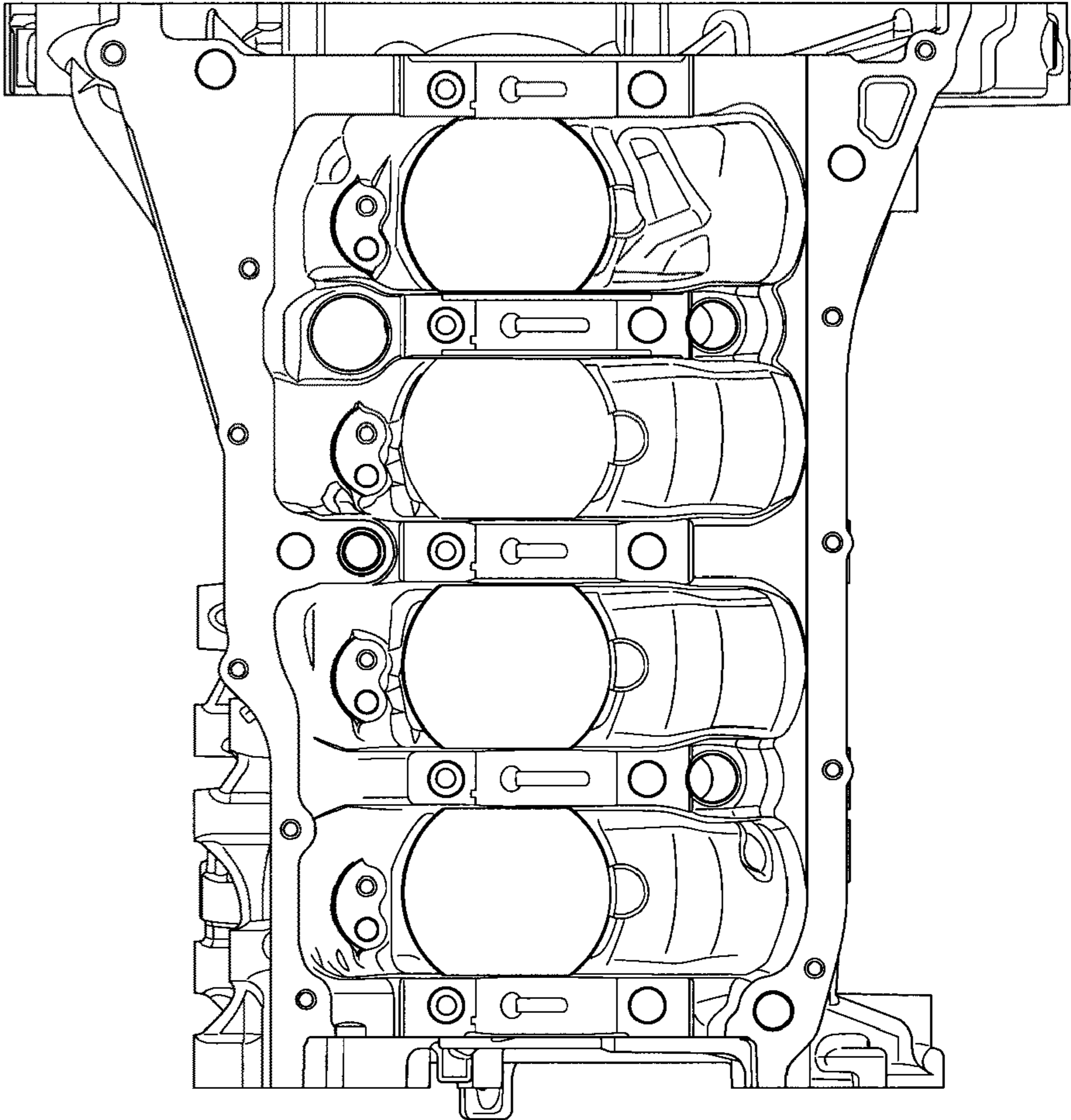

FIG.3

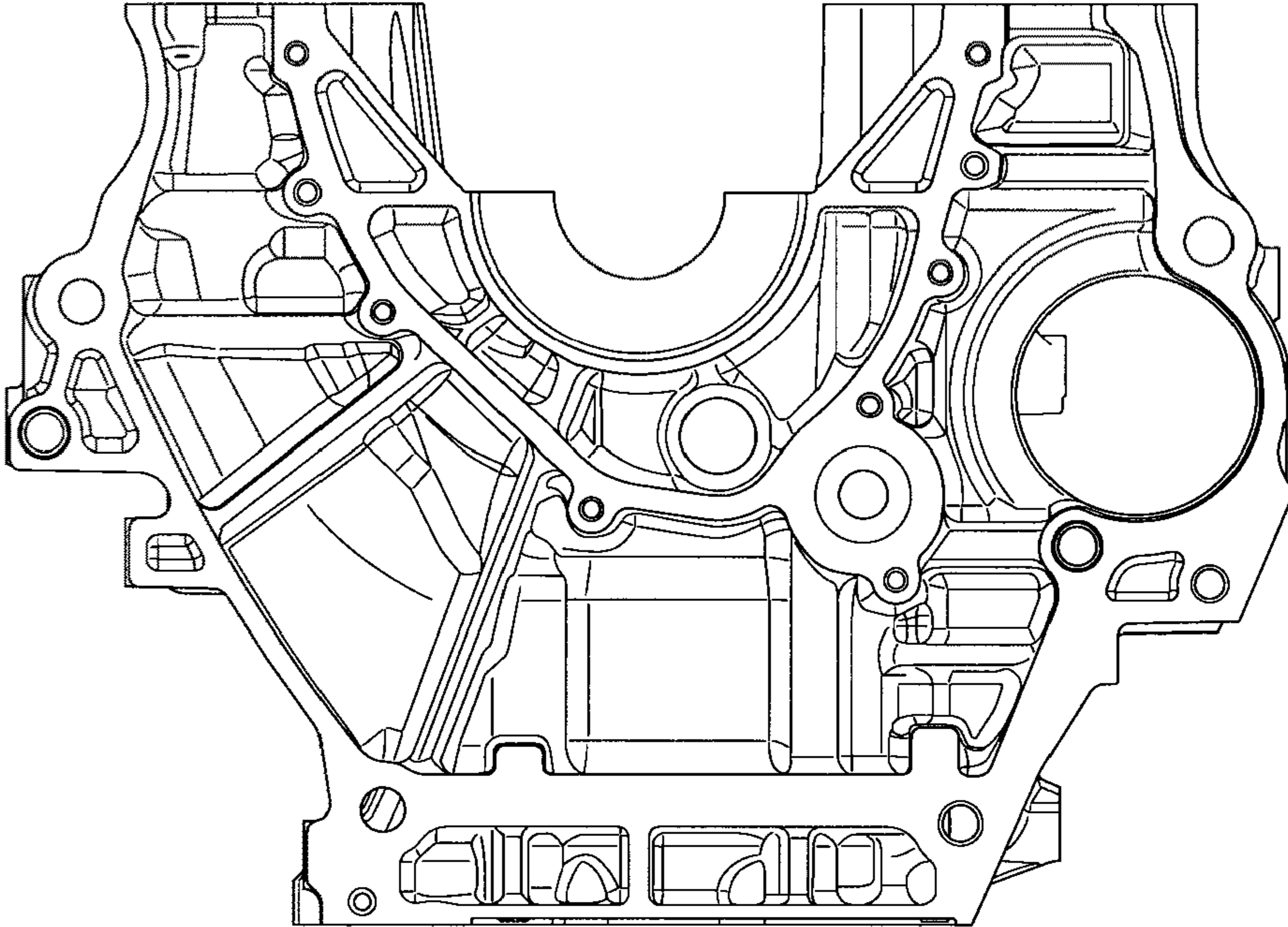

FIG.4

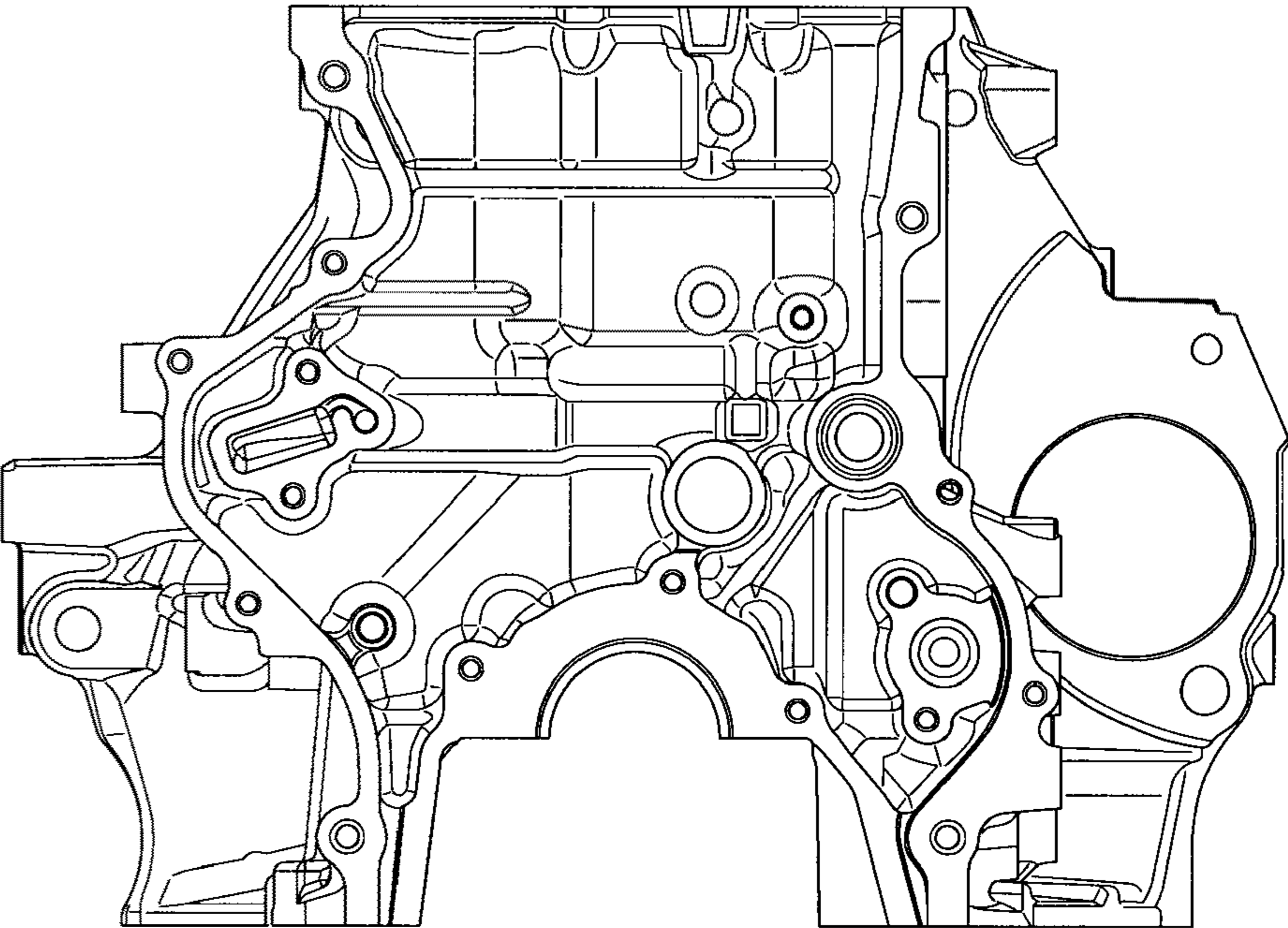

FIG.5

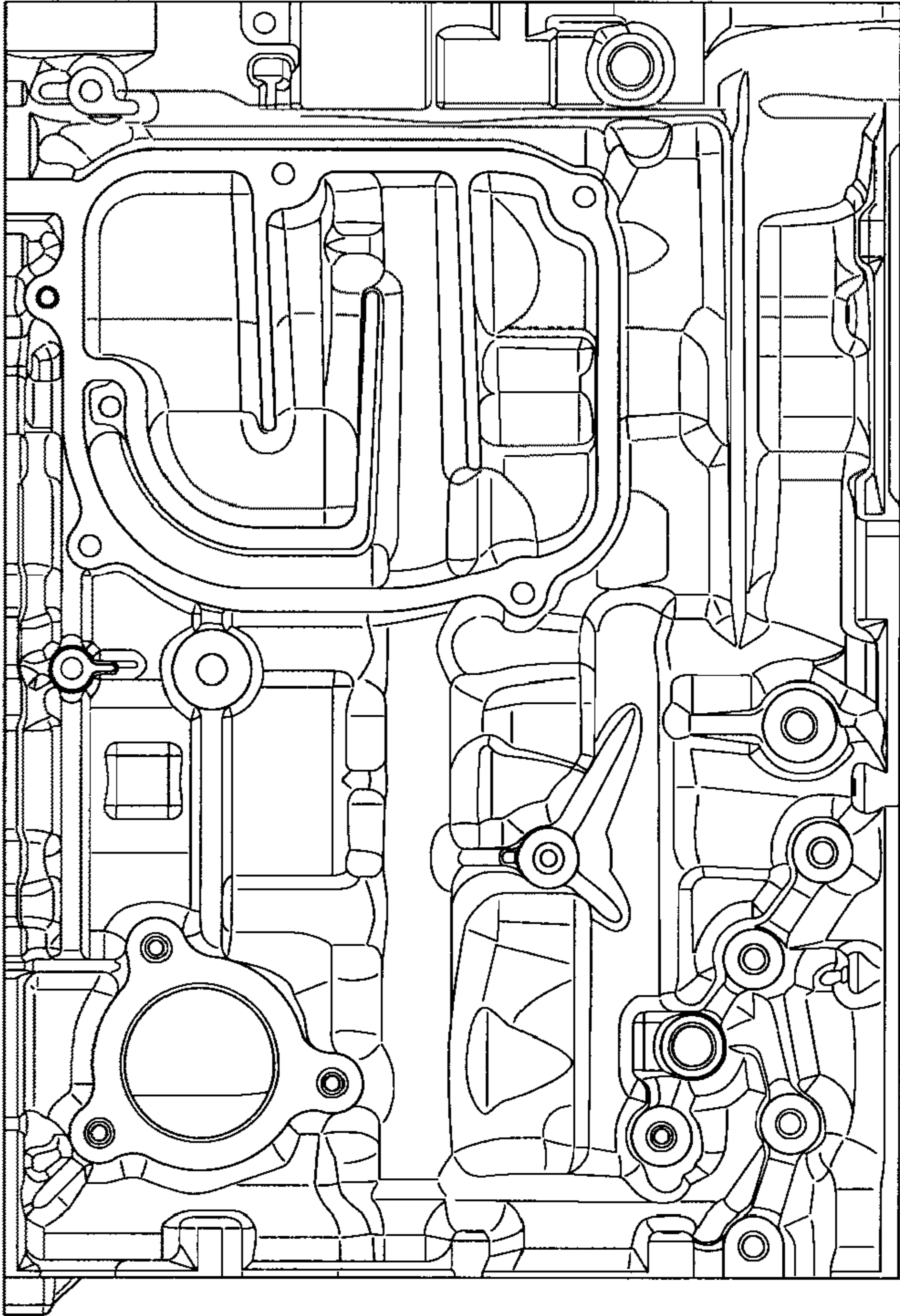

FIG.6

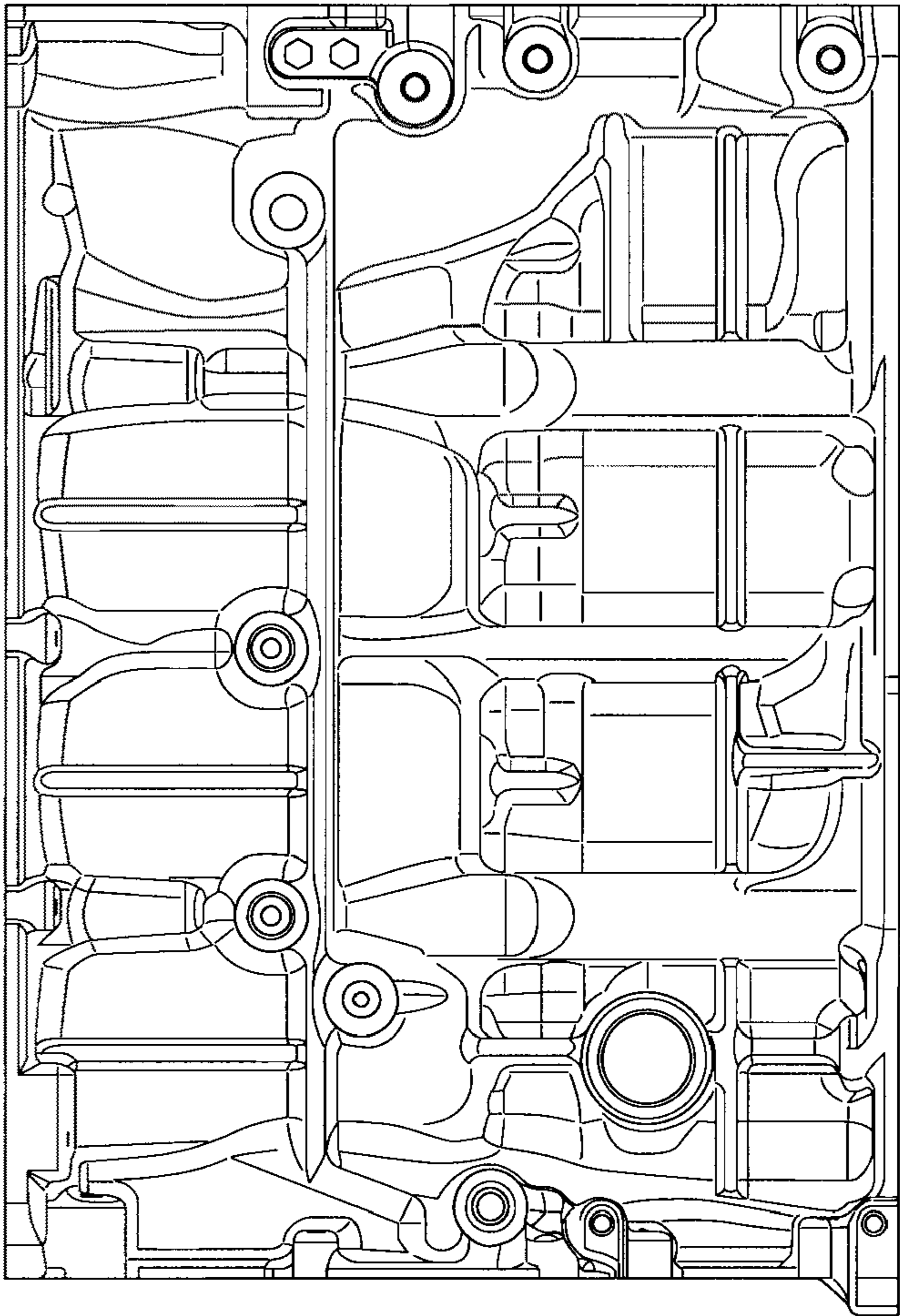

FIG.7

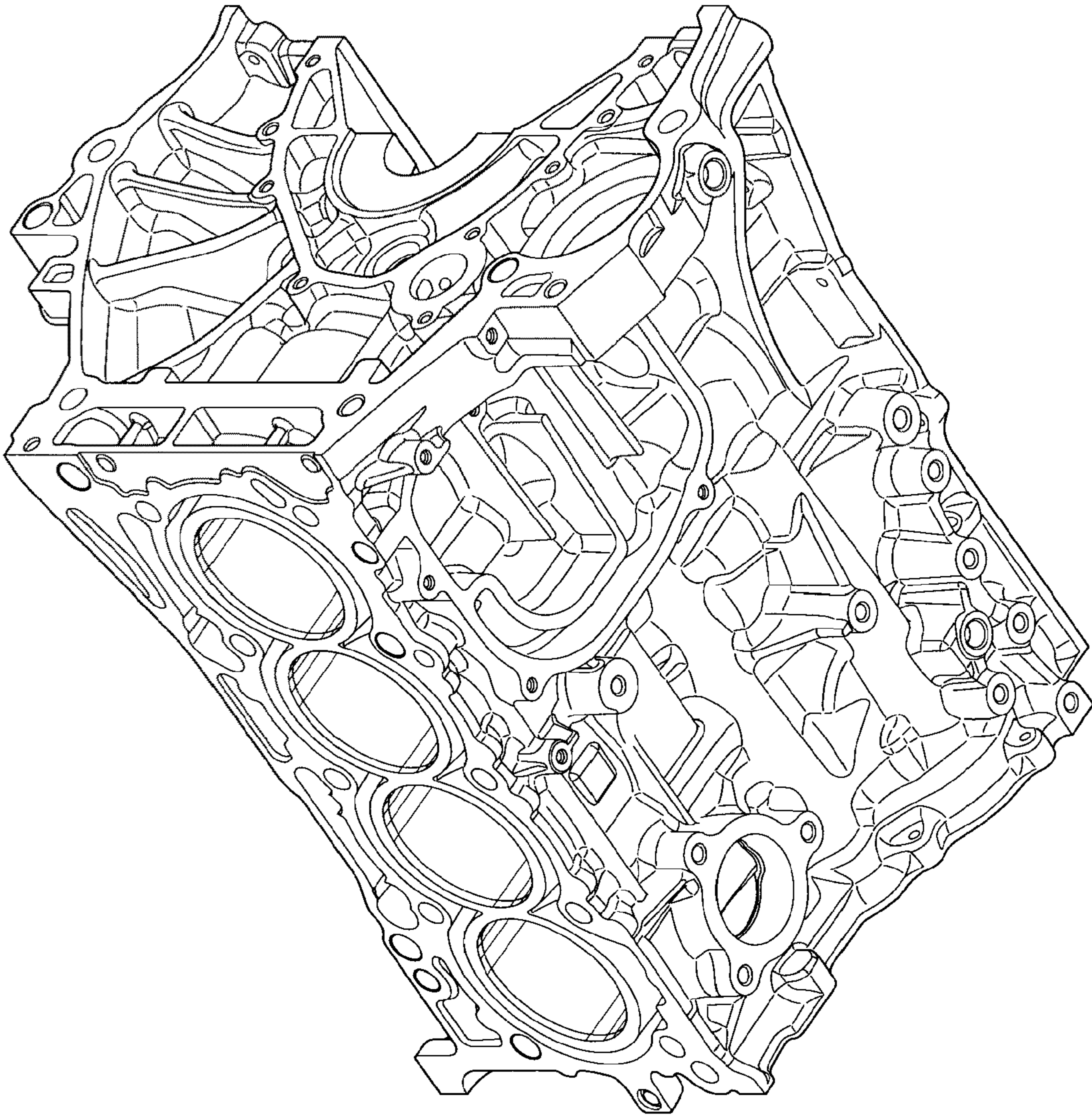



FIG.8

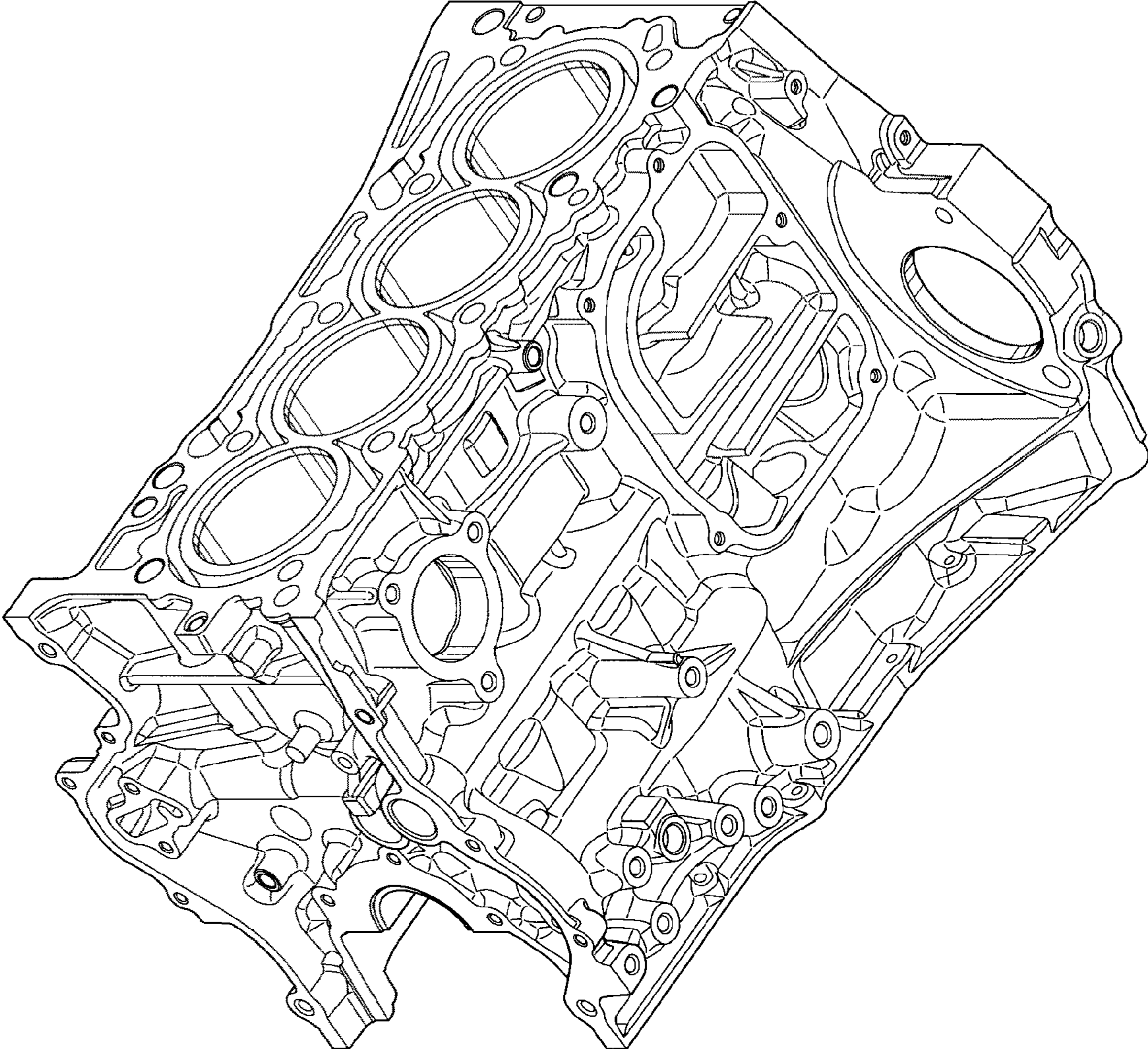

FIG.9

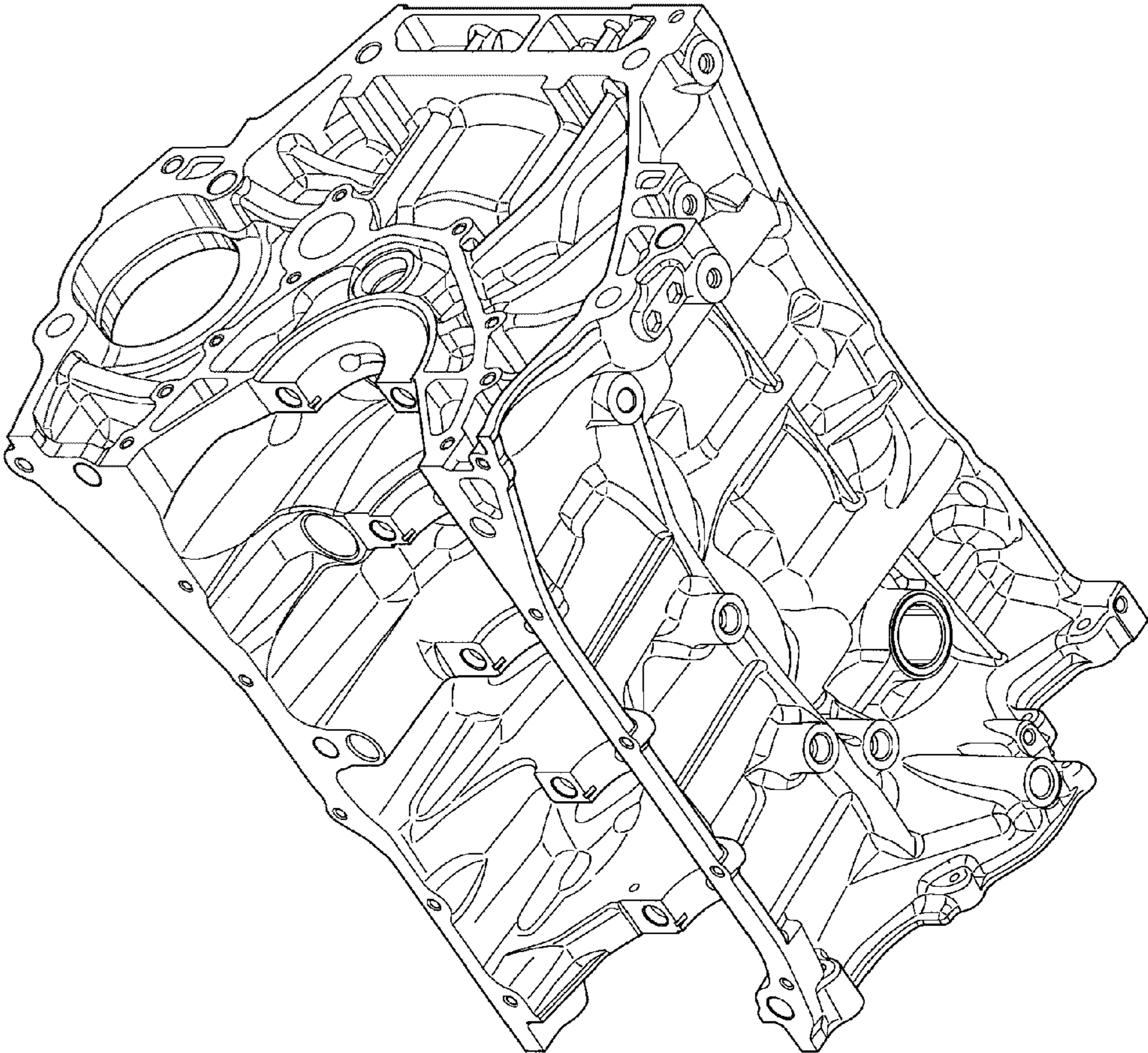

FIG.10

