



US00D722329S

(12) **United States Design Patent**
Nam

(10) **Patent No.:** **US D722,329 S**

(45) **Date of Patent:** **** Feb. 10, 2015**

(54) **REAR CYLINDER FOR AUTOMOBILES**

(71) Applicant: **GCS. Inc., Ltd**, Kimhae (KR)

(72) Inventor: **Taek Kyun Nam**, Pusan (KR)

(73) Assignee: **GCS. Inc., Ltd.**, Kimhae (KR)

(**) Term: **14 Years**

(21) Appl. No.: **29/472,110**

(22) Filed: **Nov. 8, 2013**

(30) **Foreign Application Priority Data**

May 8, 2013 (KR) 30-2013-0024267

(51) **LOC (10) Cl.** **15-02**

(52) **U.S. Cl.**
USPC **D15/9**

(58) **Field of Classification Search**
CPC F04B 53/00; F04B 1/12; F04B 39/00
USPC D15/7-9; D23/231, 232, 225; 417/60,
417/235, 265, 321, 355, 358, 363, 359,
417/410.1, 415-416, 405, 900; 60/408,
60/412; 184/26-37; 415/140-147;
123/495, 509

See application file for complete search history.

(56) **References Cited**

U.S. PATENT DOCUMENTS

6,296,457 B1 * 10/2001 Shintoku et al. 417/312
6,705,843 B1 * 3/2004 Kuo 417/312

D530,345 S * 10/2006 Chu D15/9
7,494,328 B2 * 2/2009 Bhatia et al. 417/312
7,950,904 B2 * 5/2011 Park 417/269
D648,748 S * 11/2011 Chu D15/9
D659,168 S * 5/2012 Chen D15/9
D659,169 S * 5/2012 Chen D15/9
D659,170 S * 5/2012 Chen D15/9
D659,171 S * 5/2012 Chen D15/9

* cited by examiner

Primary Examiner — Ralf Seifert

(74) *Attorney, Agent, or Firm* — Ladas & Parry LLP

(57) **CLAIM**

I claim the ornamental design for a rear cylinder for automobiles, as shown and described.

DESCRIPTION

FIG. 1 is a front perspective view of a rear cylinder for automobiles showing our new design;
FIG. 2 is a front-side elevational view thereof;
FIG. 3 is a rear-side elevational view thereof;
FIG. 4 is a left-side elevational view thereof;
FIG. 5 is a right-side elevational view thereof;
FIG. 6 is a top-side elevational view thereof;
FIG. 7 is a bottom-side elevational view thereof; and,
FIG. 8 is a rear perspective view thereof.

The broken lines are included for the purpose of illustrating portions of the rear cylinder for automobiles that form no part of the claimed design.

1 Claim, 8 Drawing Sheets

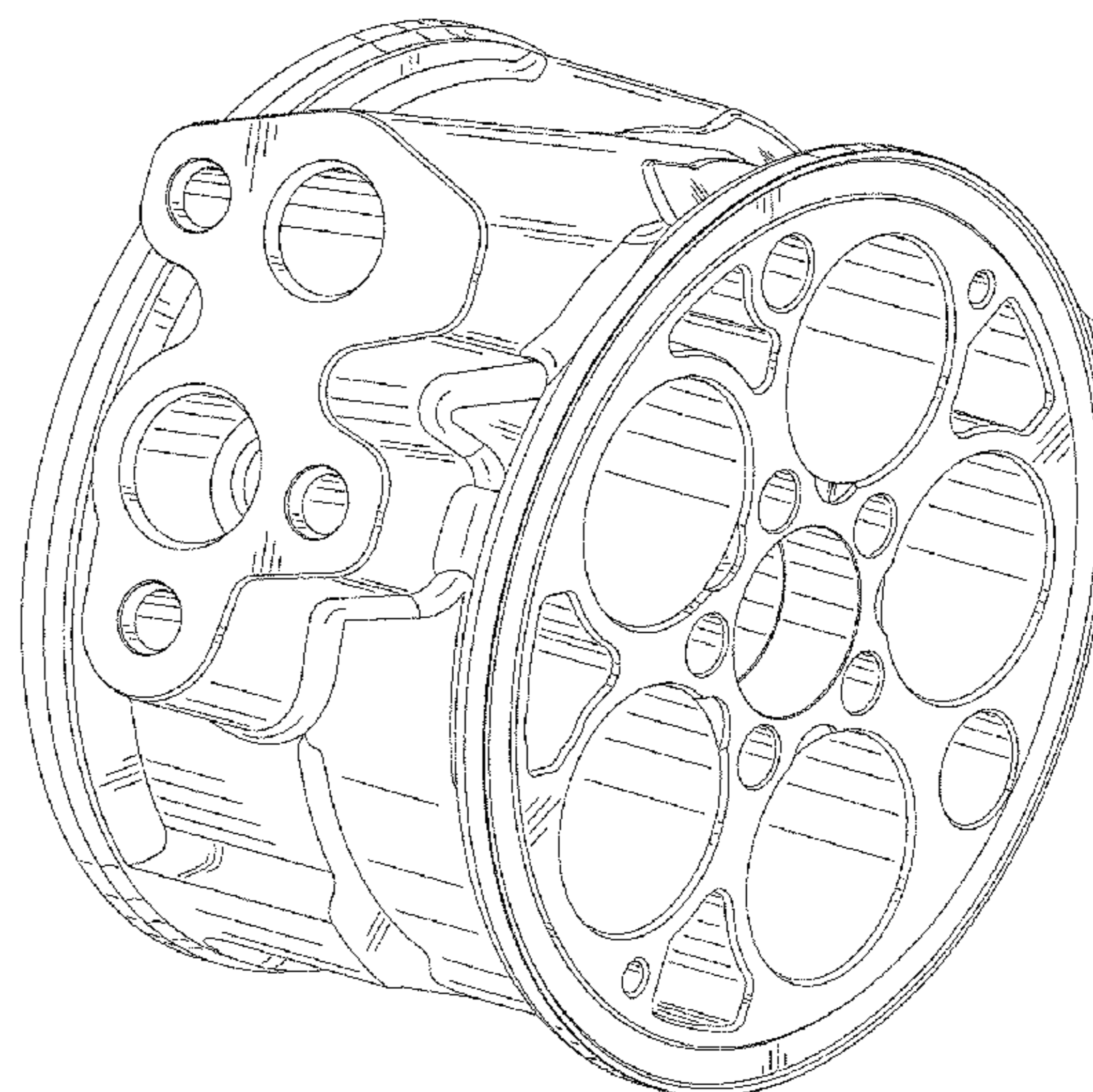
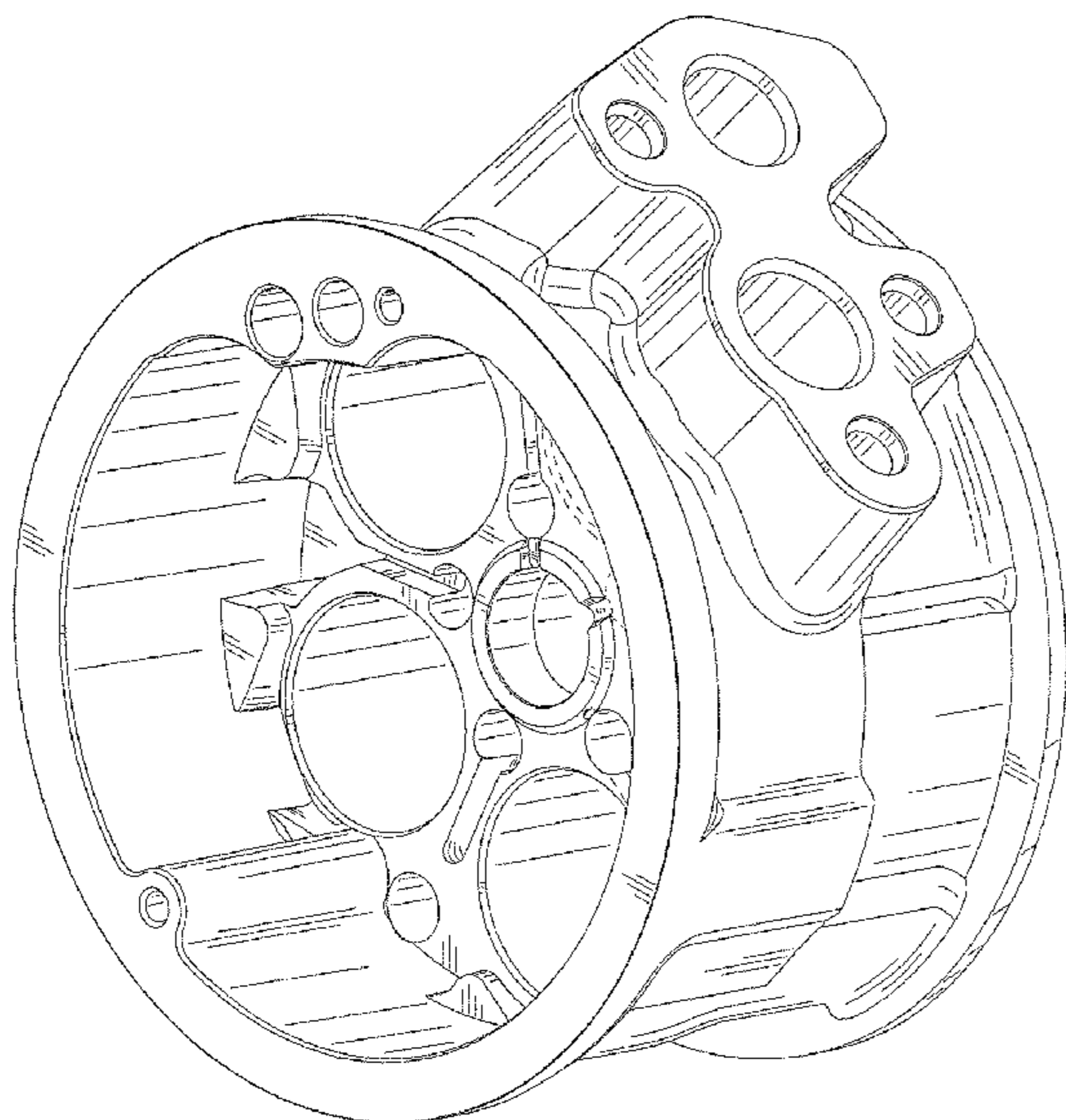

FIG. 1

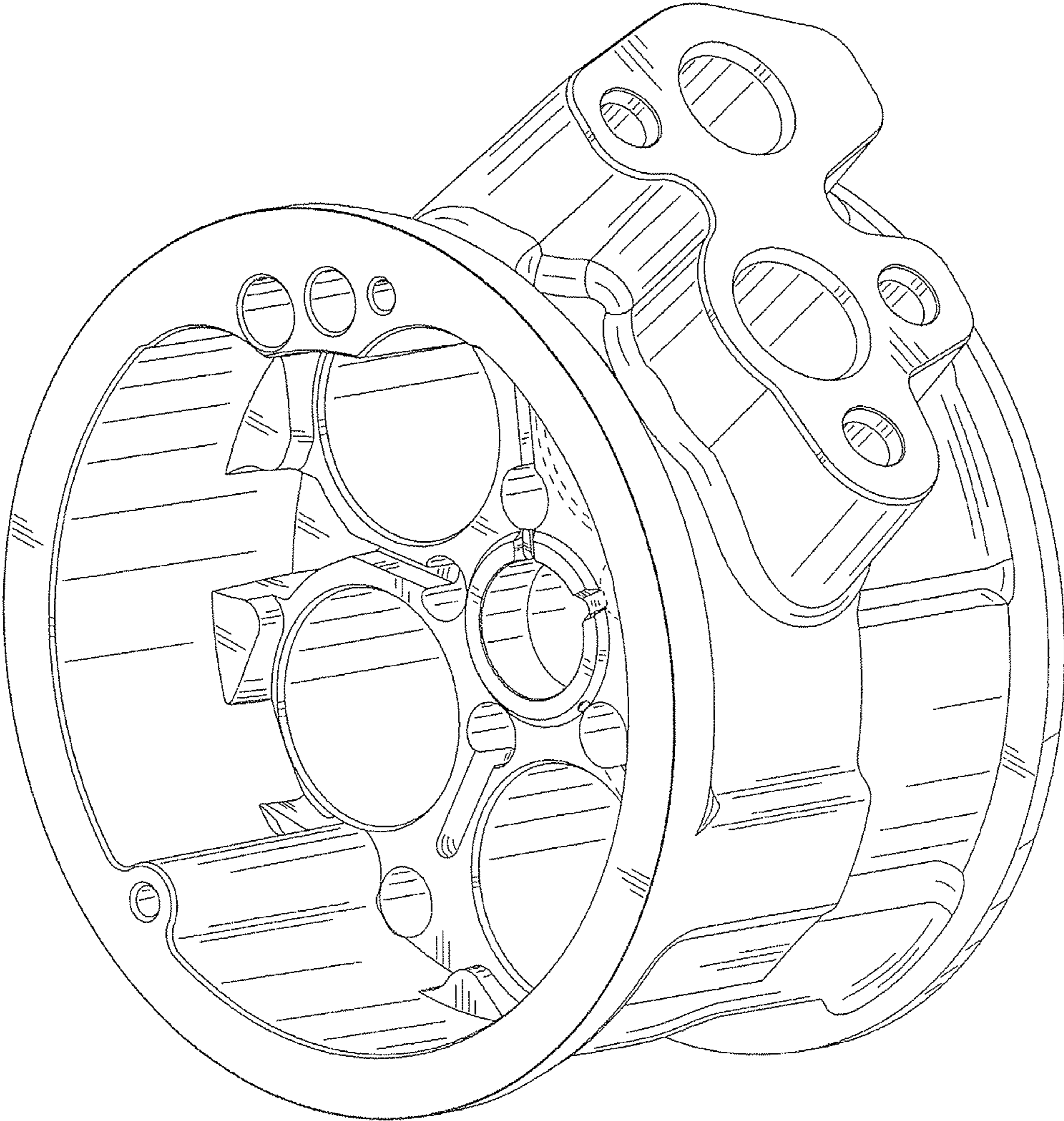

FIG. 2

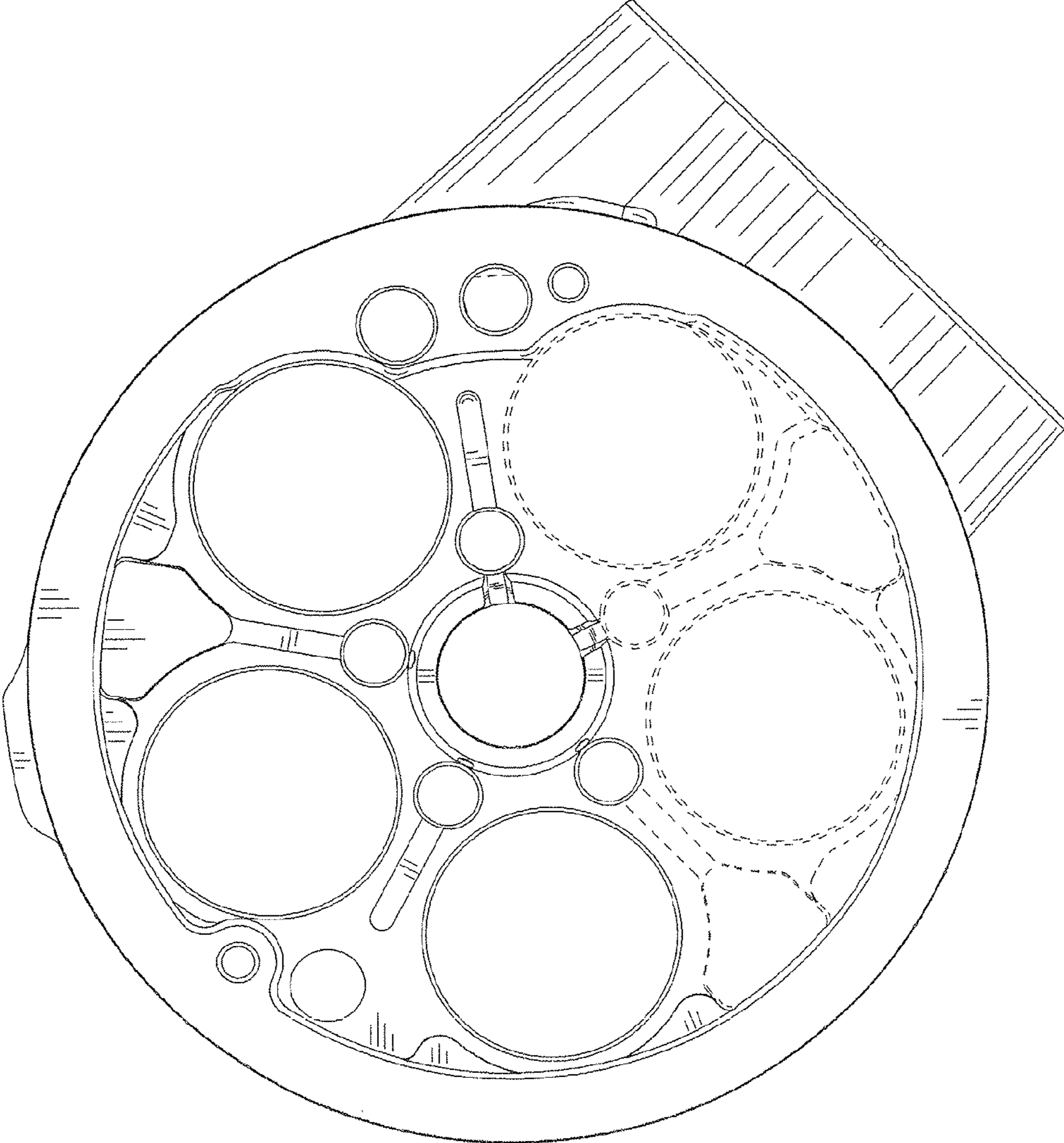

FIG. 3

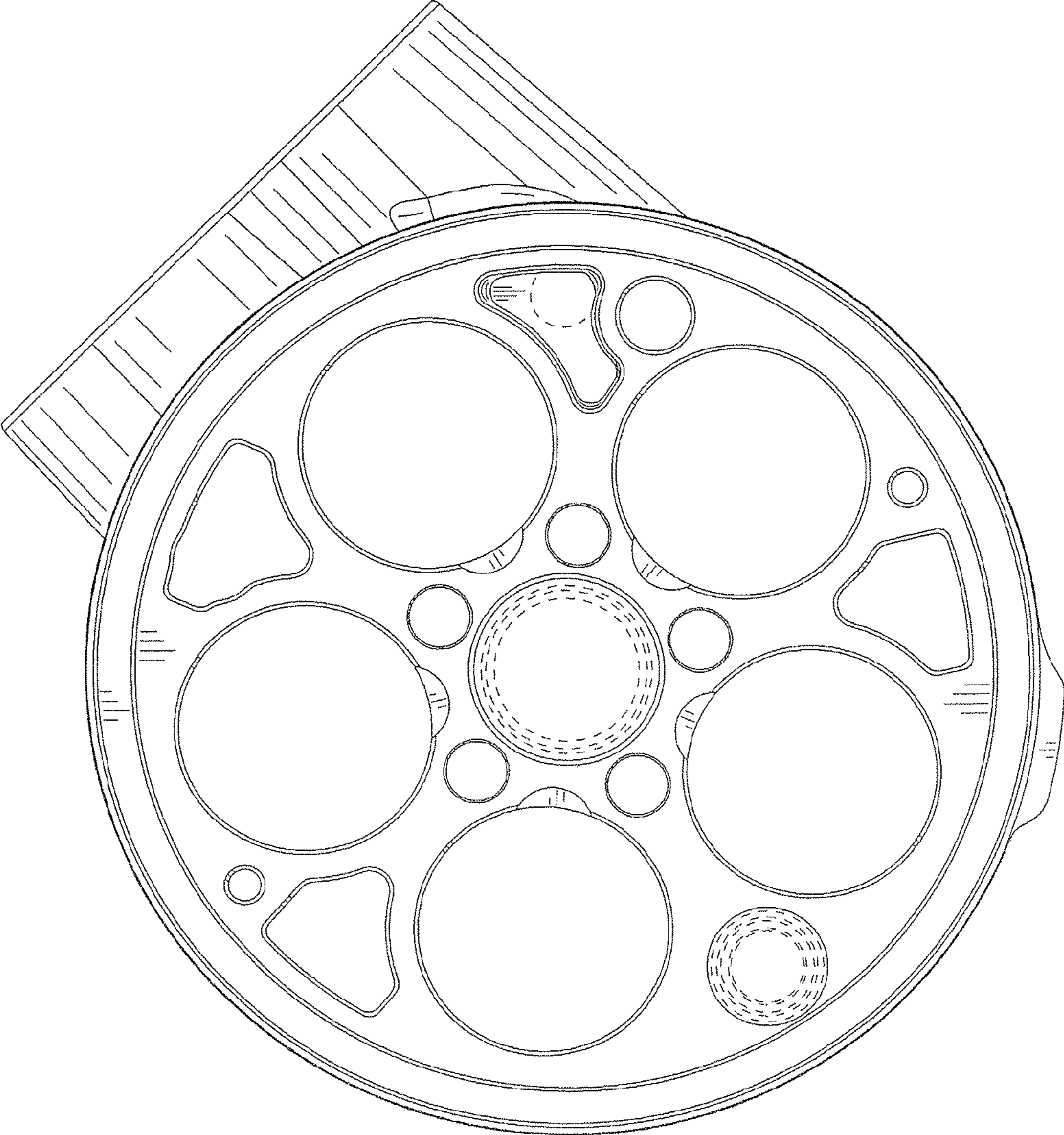

FIG. 4

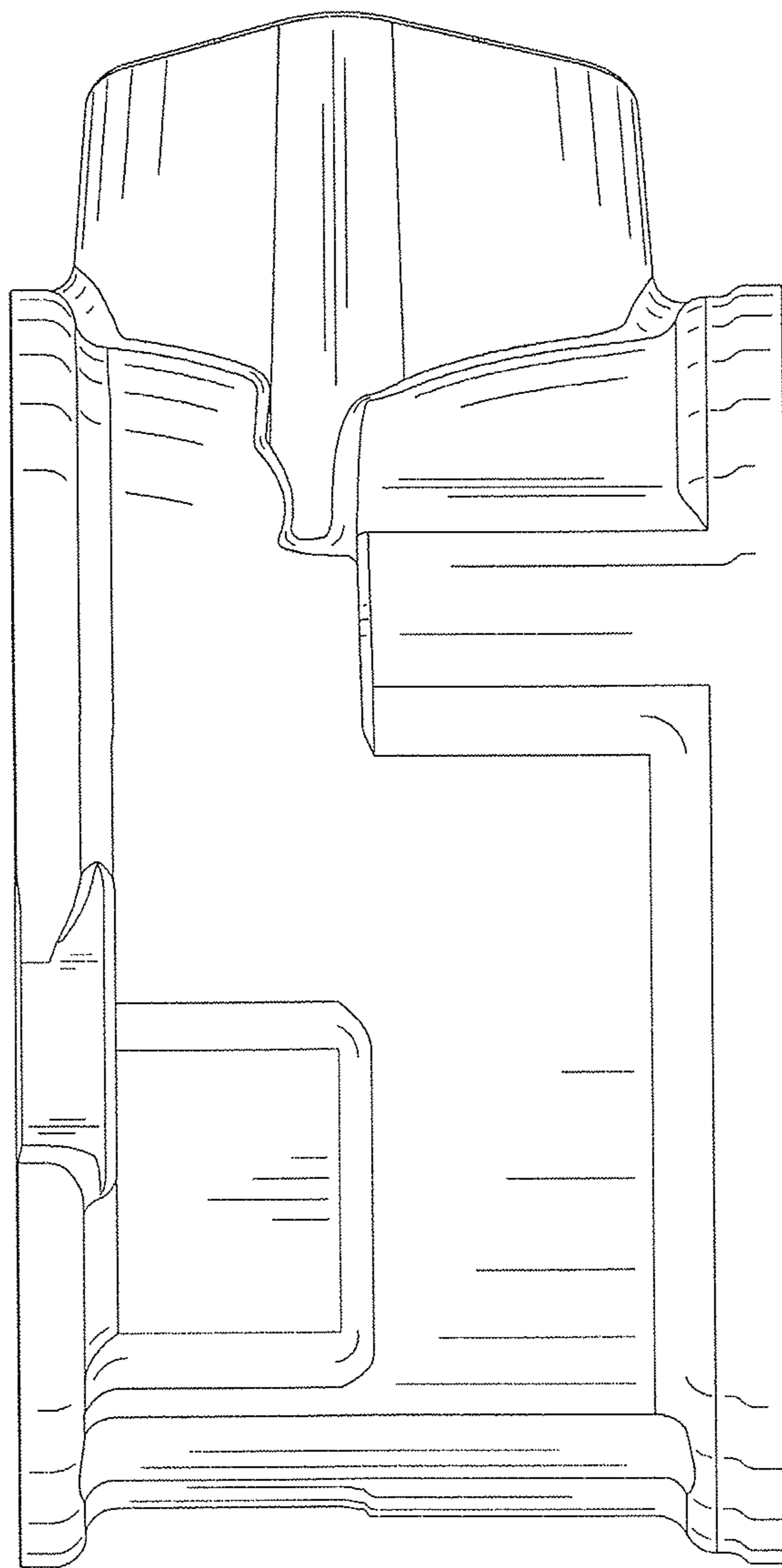

FIG. 5

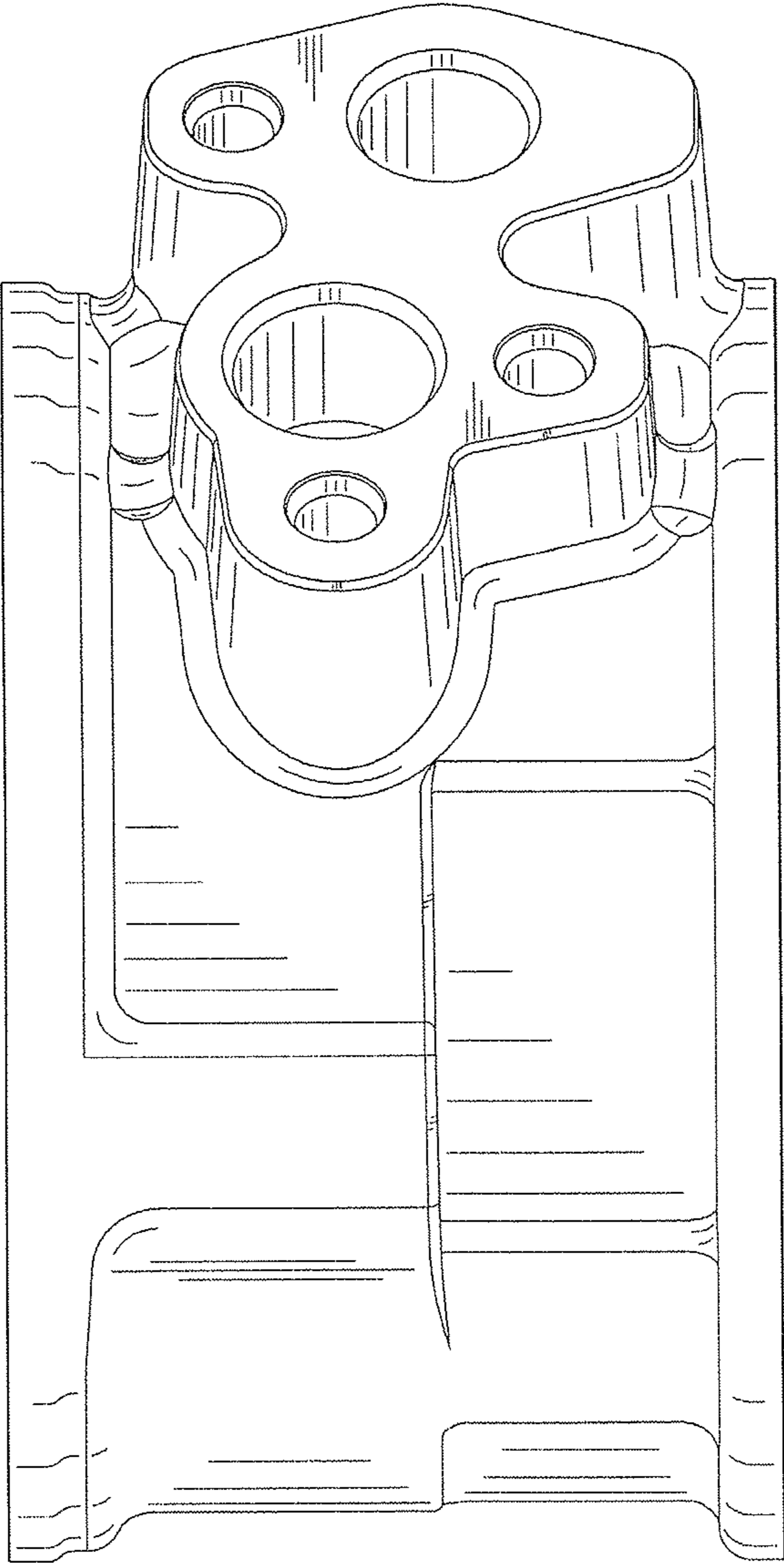

FIG. 6

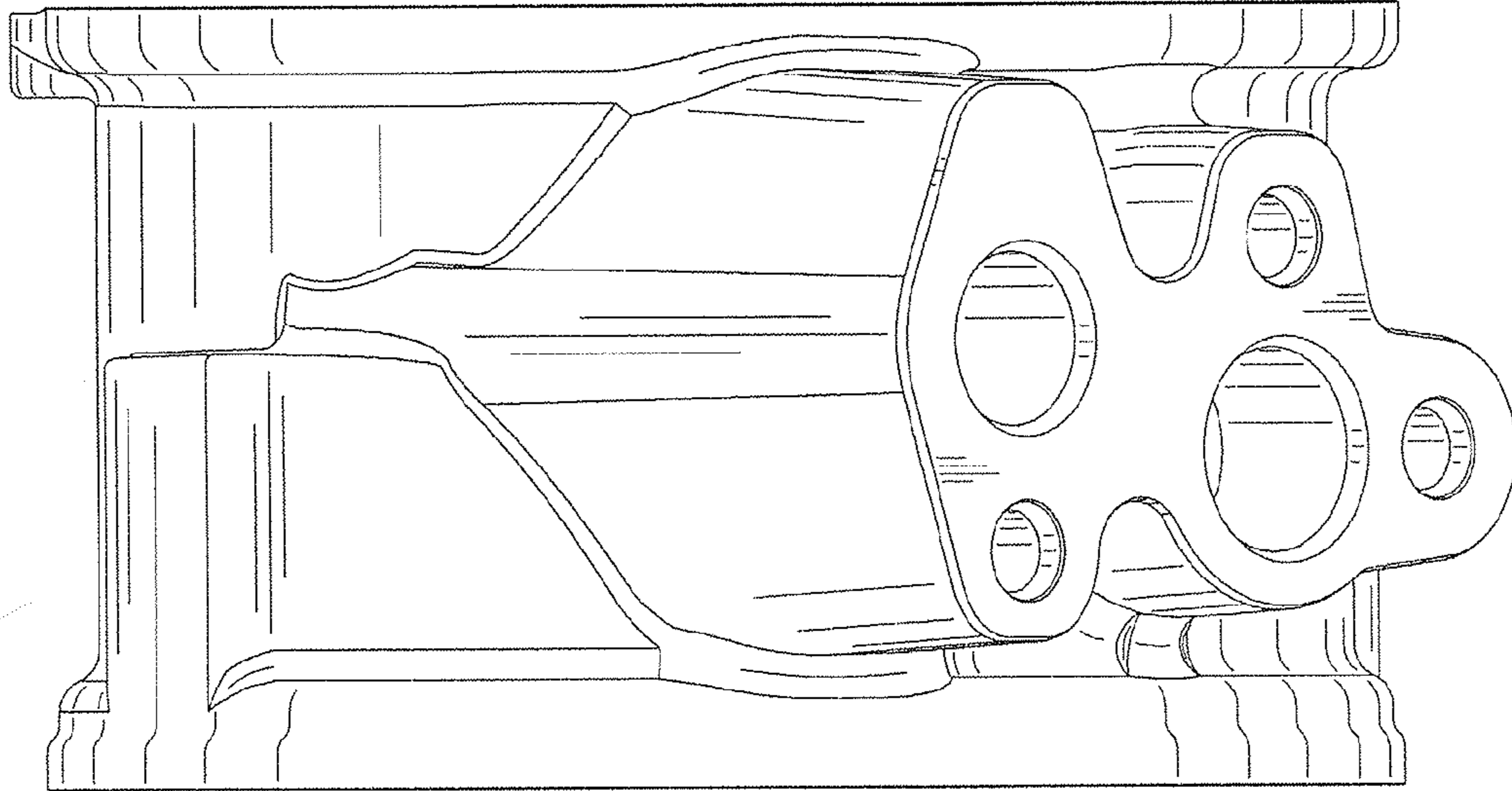

FIG. 7

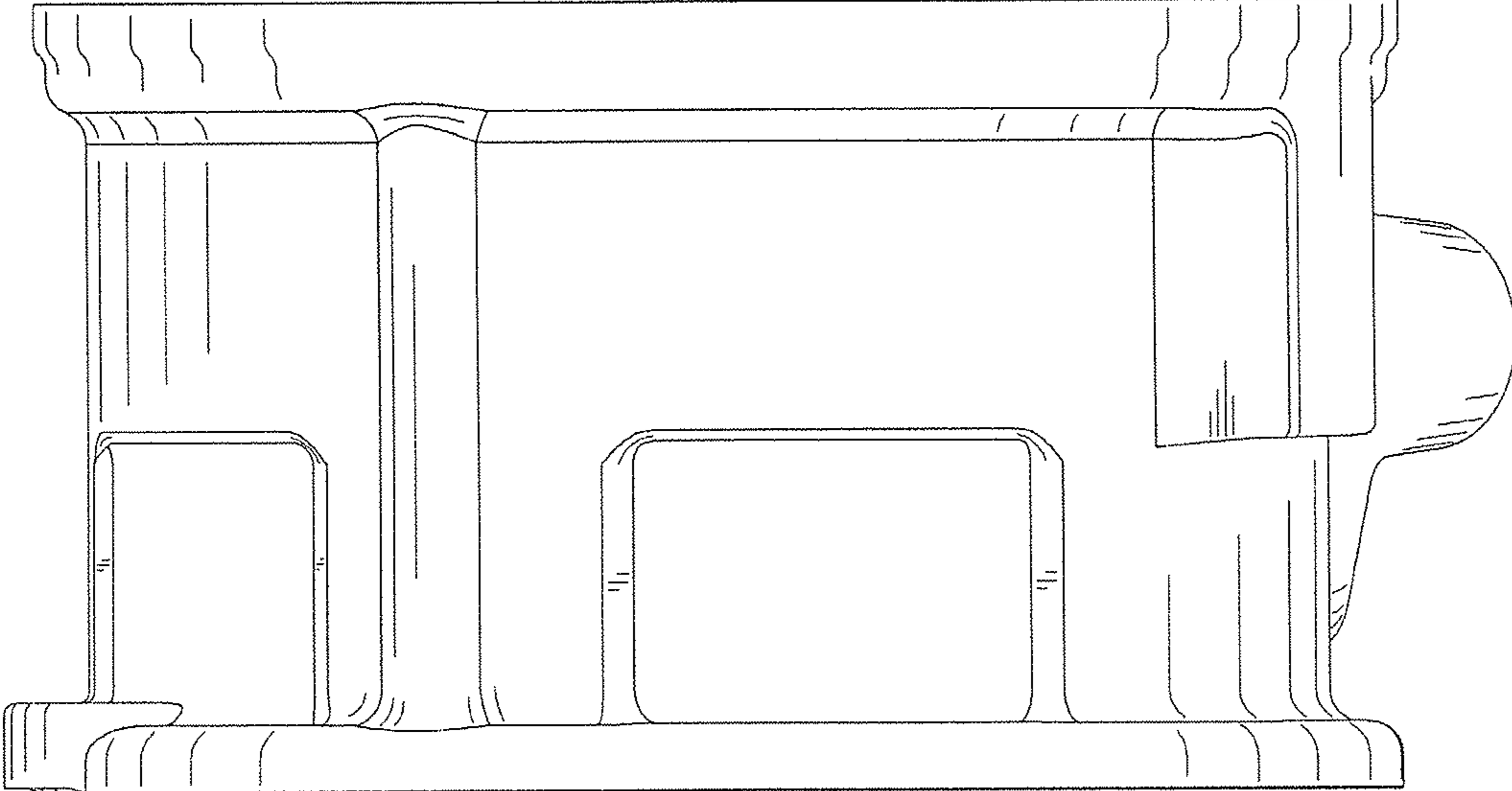

FIG. 8

