



US00D722283S

(12) **United States Design Patent**  
**Hanaoka et al.**

(10) **Patent No.:** **US D722,283 S**  
(45) **Date of Patent:** **\*\* Feb. 10, 2015**

(54) **AUTOMOBILE**

(71) Applicant: **Honda Motor Co., Ltd.**, Tokyo (JP)

(72) Inventors: **Hisakazu Hanaoka**, Saitama (JP);  
**Hiroshi Yoshida**, Saitama (JP);  
**Mitsuhiro Abe**, Saitama (JP)

(73) Assignee: **Honda Motor Co., Ltd.**, Tokyo (JP)

(\*\*) Term: **14 Years**

(21) Appl. No.: **29/475,041**

(22) Filed: **Nov. 27, 2013**

(30) **Foreign Application Priority Data**

May 31, 2013 (JP) ..... 2013-012162

(51) **LOC (10) Cl.** ..... **12-08**

(52) **U.S. Cl.**  
USPC ..... **D12/92**

(58) **Field of Classification Search**  
CPC ..... B62D 35/00  
USPC ..... D12/86, 90-92; D21/421, 433, 434;  
296/181.1, 181.5  
See application file for complete search history.

(56) **References Cited**

**U.S. PATENT DOCUMENTS**

D612,299 S \* 3/2010 Ito et al. .... D12/92  
D626,457 S \* 11/2010 Lian et al. .... D12/92  
D628,940 S \* 12/2010 Bischoff et al. .... D12/92  
D628,941 S \* 12/2010 Yi ..... D12/92  
D630,555 S \* 1/2011 Koshino et al. .... D12/92  
D630,557 S \* 1/2011 Eum ..... D12/92  
D632,222 S \* 2/2011 Bischoff et al. .... D12/92

D636,296 S \* 4/2011 Lian et al. .... D12/92  
D640,603 S \* 6/2011 Ham ..... D12/92  
D670,201 S \* 11/2012 Ham ..... D12/92  
D696,158 S \* 12/2013 Akejima ..... D12/92  
D702,597 S \* 4/2014 Wada et al. .... D12/92

**OTHER PUBLICATIONS**

Russian Office Action dated Jul. 21, 2014, issued in Russian Patent Application No. 2013504572, w/English translation (9 pages).  
<https://oami.europa.eu/eSearch/#advanced/designs>,  
“EM001276471-0003”, Cited in Russian Office Action dated Jul. 21, 2014.

\* cited by examiner

*Primary Examiner* — Melody N Brown

(74) *Attorney, Agent, or Firm* — Westerman, Hattori,  
Daniels & Adrian, LLP

(57) **CLAIM**

The ornamental design for an automobile, as shown and described.

**DESCRIPTION**

FIG. 1 is a left front perspective view of an automobile showing our new design;  
FIG. 2 is a right front perspective view thereof;  
FIG. 3 is a left side elevational view thereof;  
FIG. 4 is a front elevational view thereof;  
FIG. 5 is a rear elevational view thereof;  
FIG. 6 is a right side elevational view thereof; and,  
FIG. 7 is a top plan view thereof.  
The broken lines illustrate environmental structure only and form no part of the claimed design.

**1 Claim, 7 Drawing Sheets**

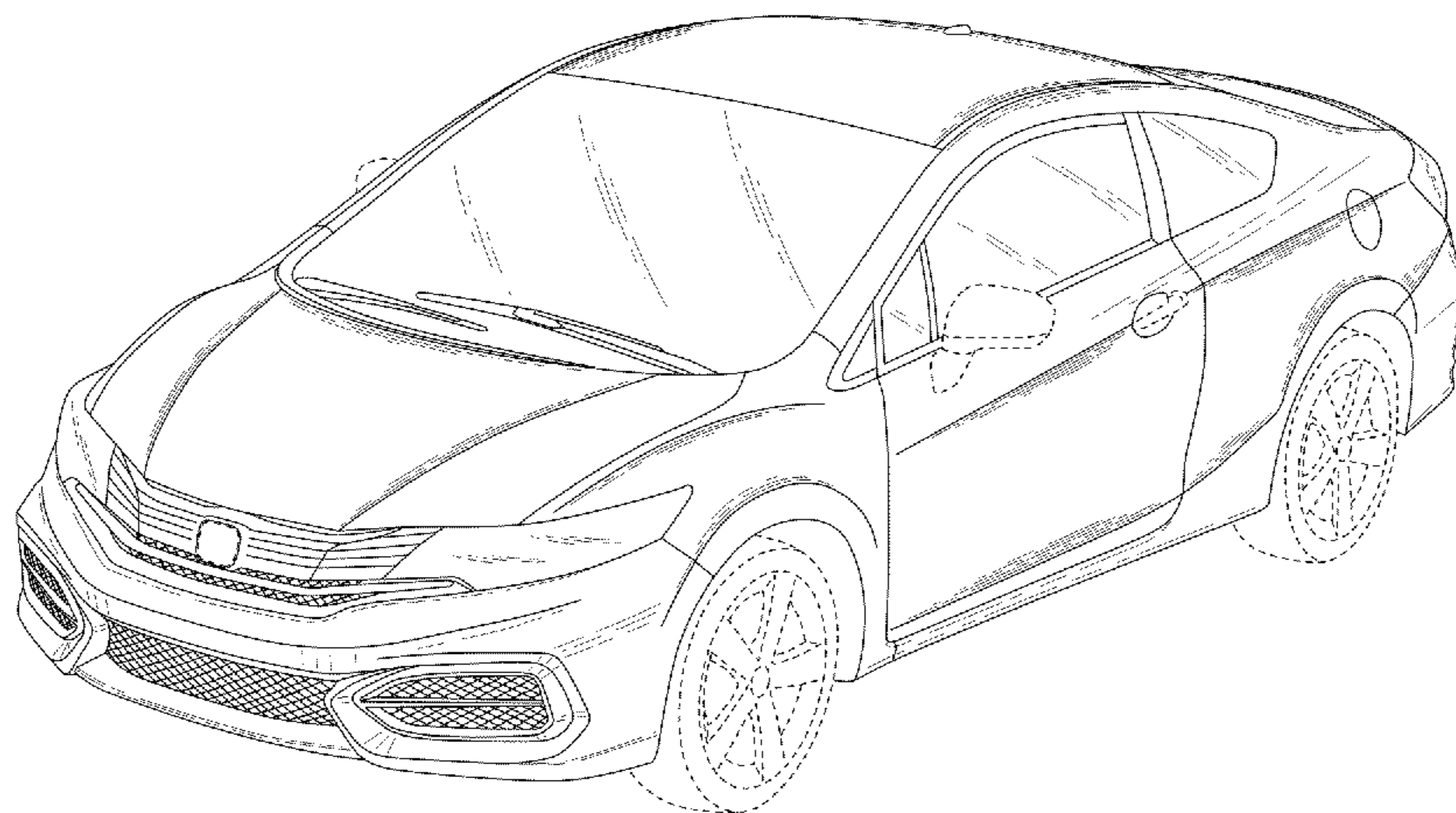

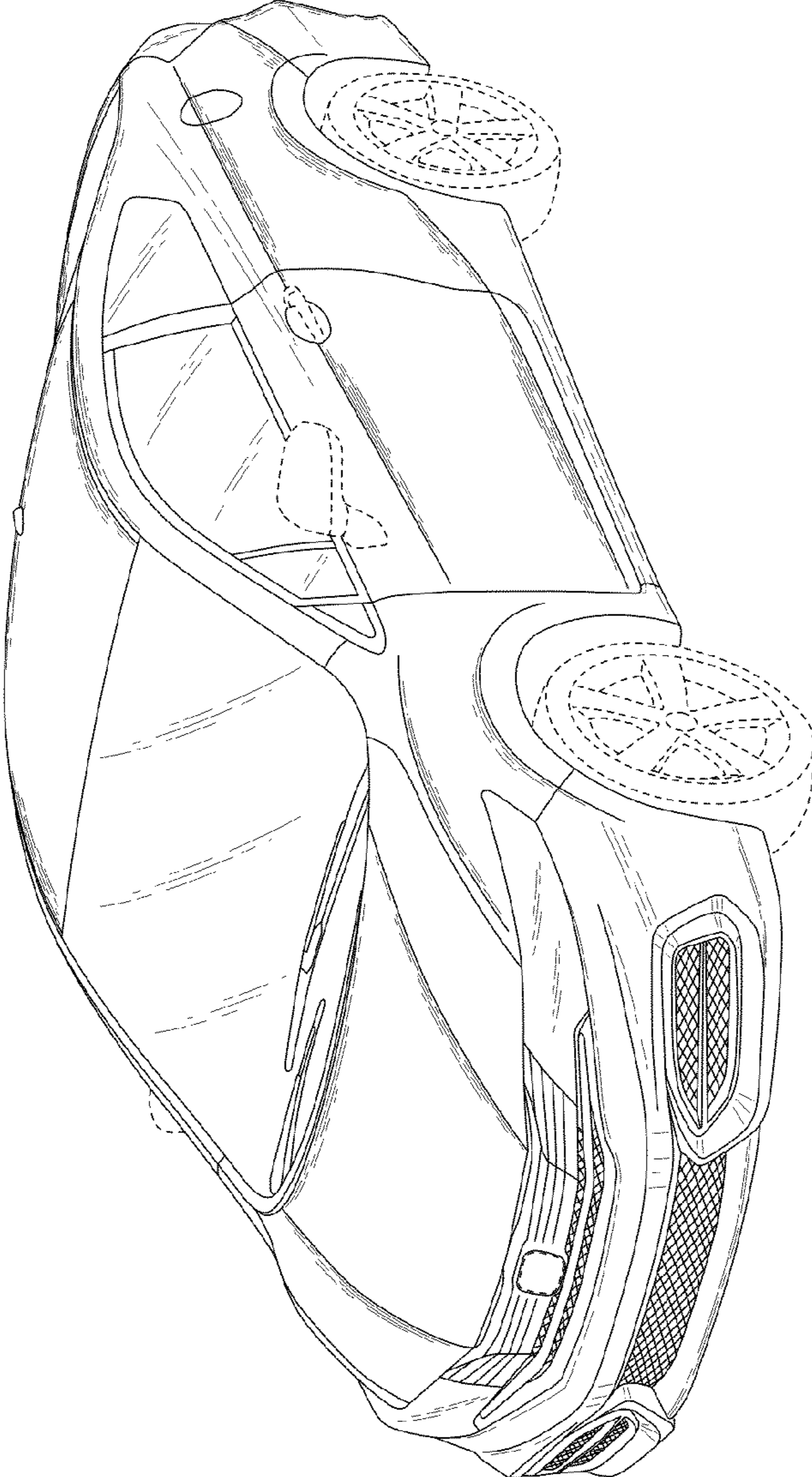

FIG.1

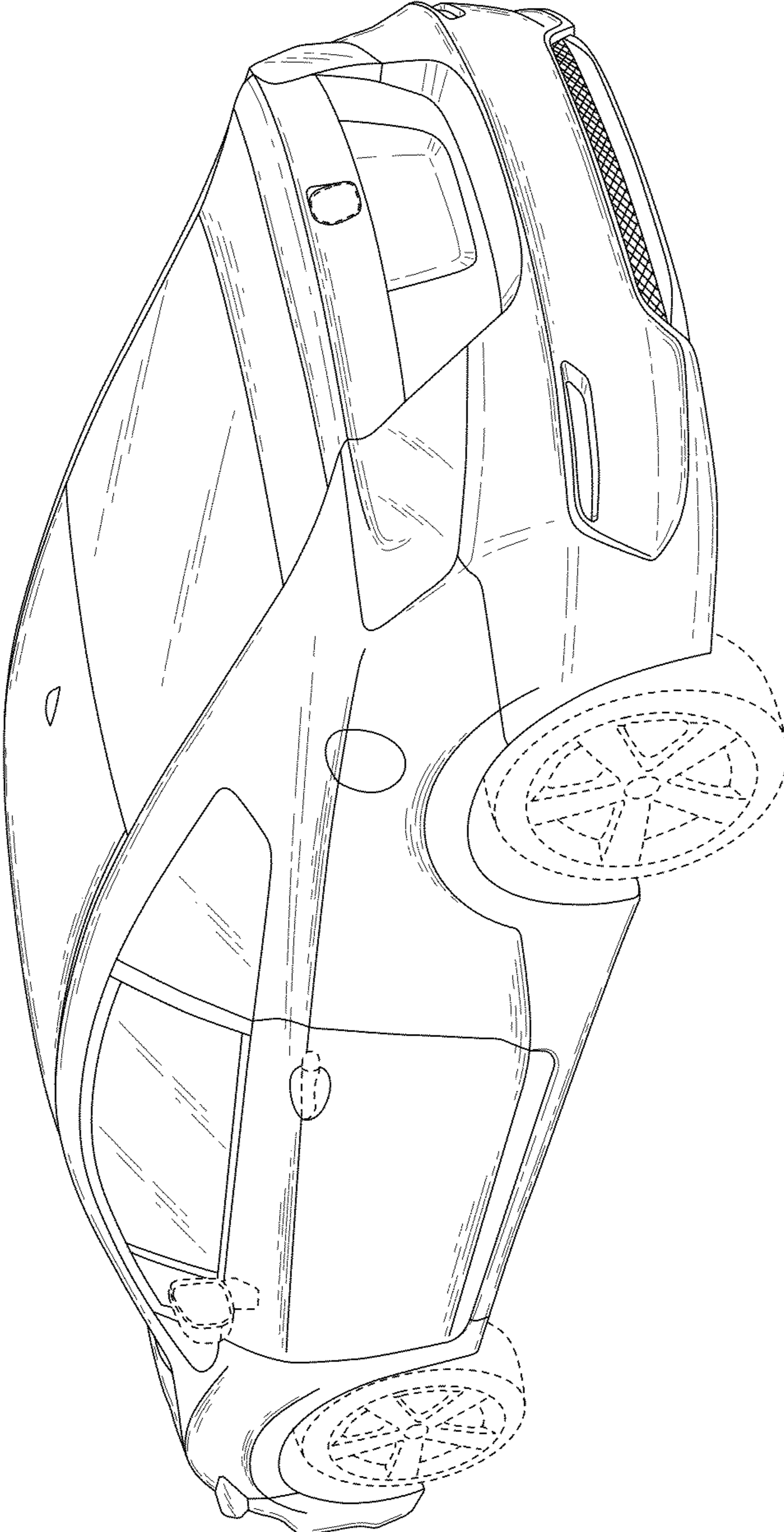

FIG.2

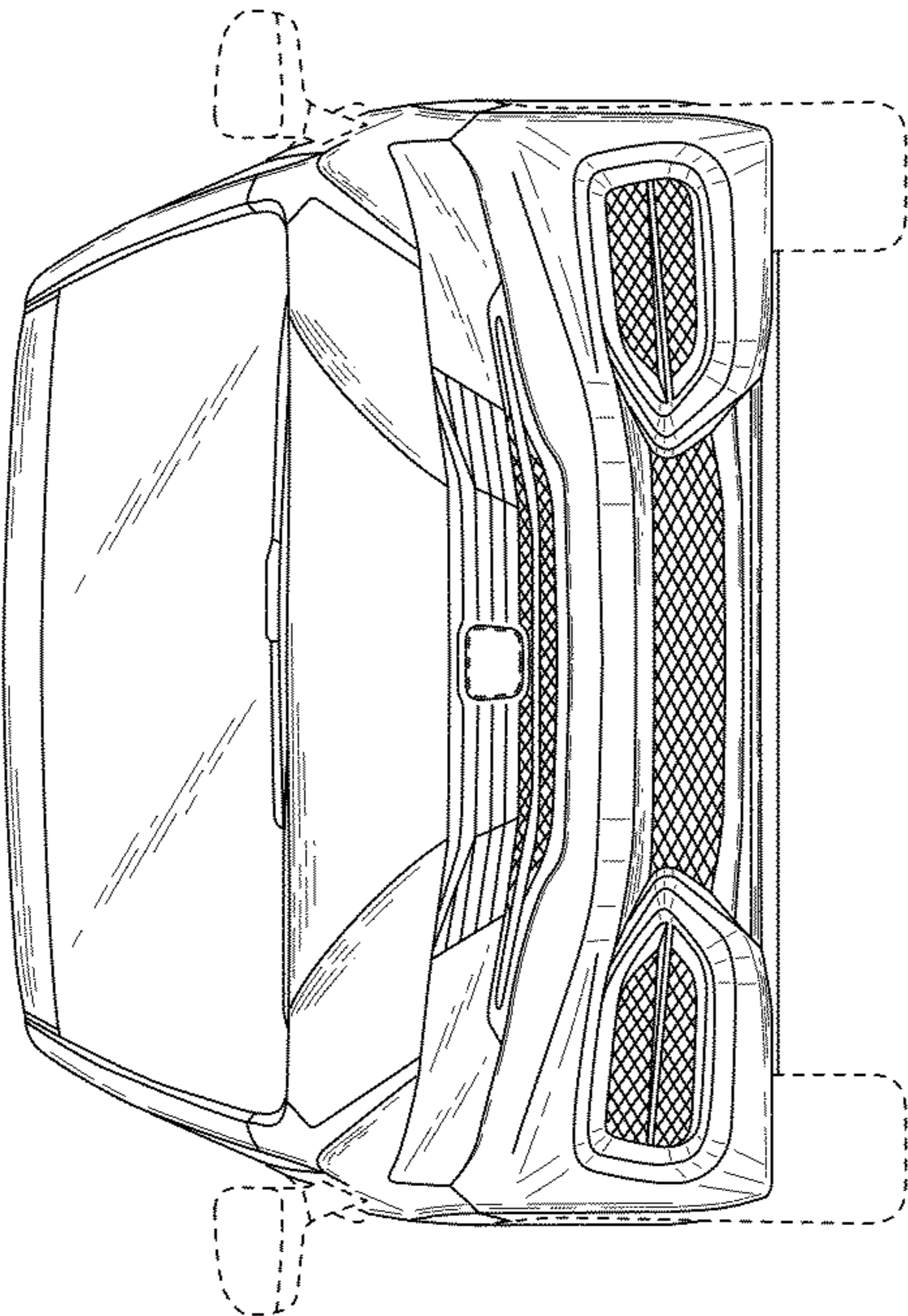

FIG.3

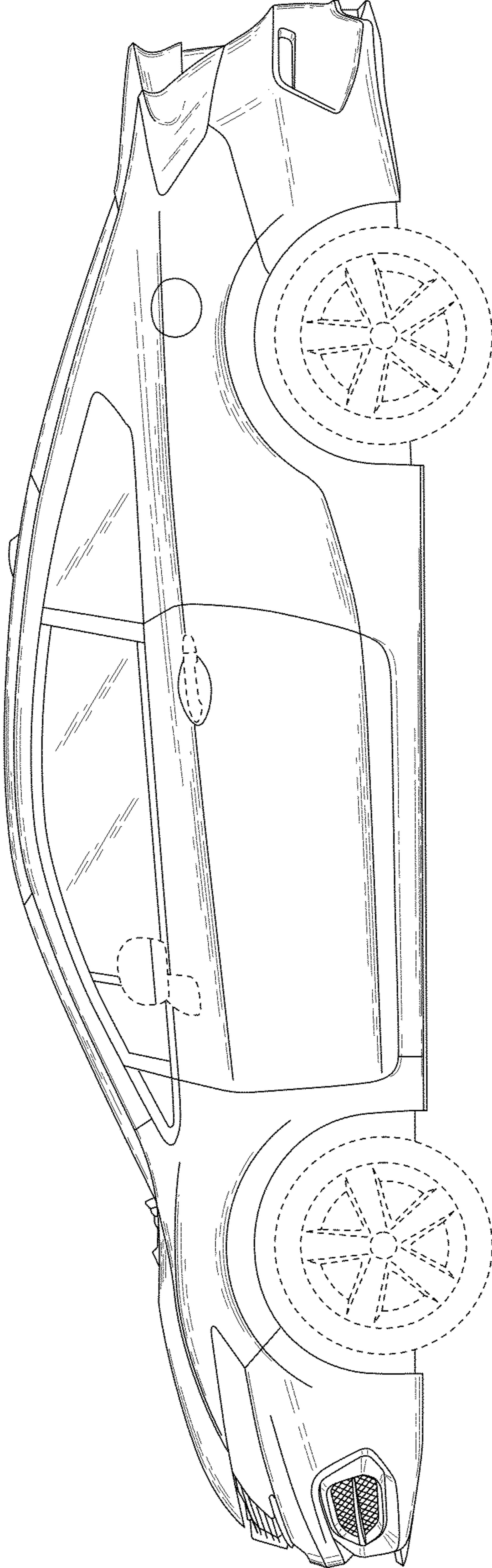

FIG.4

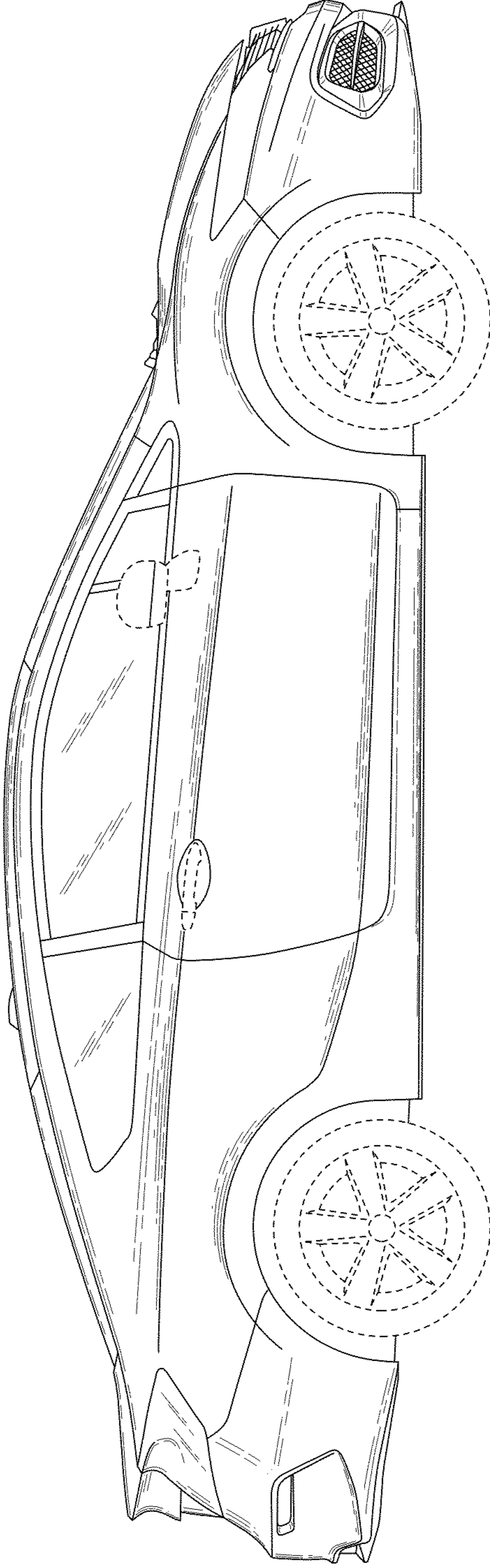

FIG.5

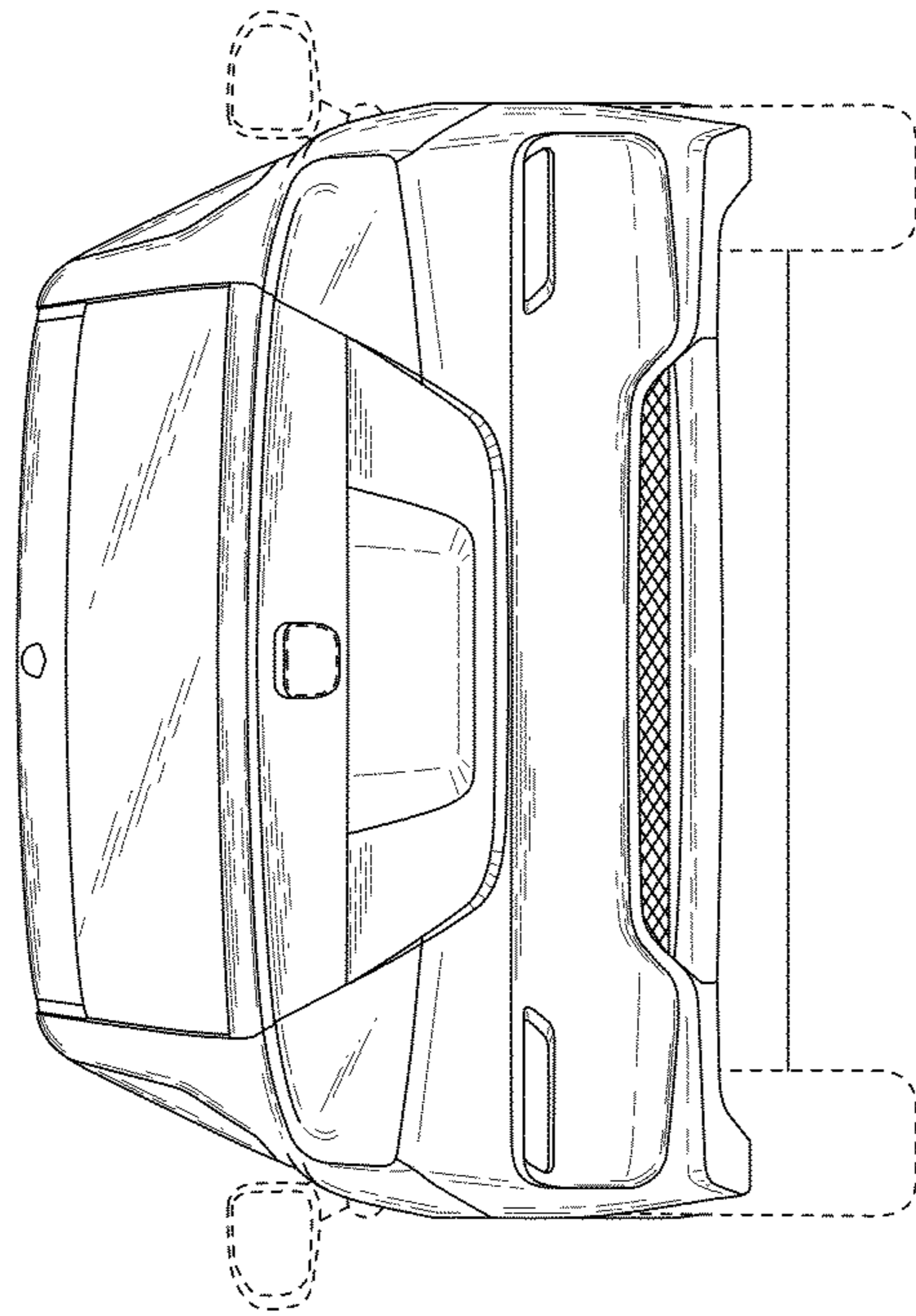

FIG.6

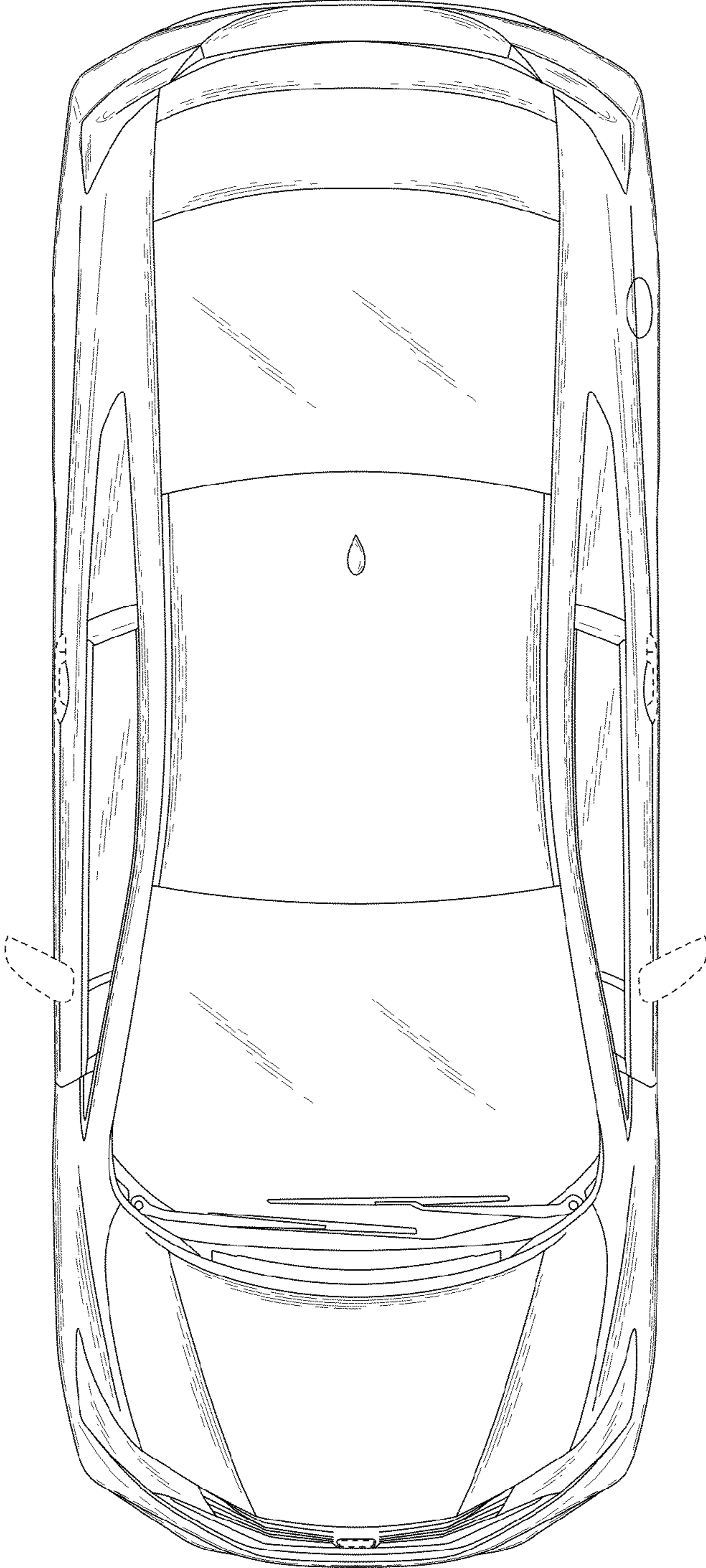

FIG.7