



US00D721537S

(12) **United States Design Patent**  
**Schmidt**

(10) **Patent No.:** **US D721,537 S**  
(45) **Date of Patent:** **\*\* Jan. 27, 2015**

(54) **KNIFE BOLSTER**

(71) Applicant: **Brothers Brands Inc.**, Westwood, NJ  
(US)

(72) Inventor: **Jordan Schmidt**, Westwood, NJ (US)

(73) Assignee: **Brothers Brands, Inc.**, Westwood, NJ  
(US)

(\*\*) Term: **14 Years**

(21) Appl. No.: **29/475,541**

(22) Filed: **Dec. 4, 2013**

(51) **LOC (10) Cl.** ..... **07-03**

(52) **U.S. Cl.**

USPC ..... **D7/401.2**; D7/642; D7/649

(58) **Field of Classification Search**

CPC . A47G 21/06; A47G 21/065; A61B 17/3211;  
A61B 17/3213; B21D 53/64; B26B 1/00;  
B26B 1/08; B26B 1/10; B26B 3/00; B26B  
3/02; B26B 3/03; B26B 3/04; B26B 3/06;  
B26B 5/00; B26B 5/001; B26B 5/007; B26B  
7/00; B26B 7/005; B26B 9/00; B26B 9/02;  
B26B 11/00; B26B 11/006; B26B 17/00;  
B26B 17/006

USPC ..... D7/387, 393-395, 401.2, 642-652, 693,  
D7/695-696; D8/93, 97-100, 107, 300,  
D8/303, 321; D22/117-118; 30/136, 142,  
30/147-149, 329, 340-345

See application file for complete search history.

(56) **References Cited**

U.S. PATENT DOCUMENTS

D473,430 S *	4/2003	Fedor et al. ....	D7/649
D479,104 S *	9/2003	Onion .....	D7/649
D513,927 S *	1/2006	Chen .....	D7/395
D539,083 S *	3/2007	Molayem .....	D7/393
D547,135 S *	7/2007	Hasegawa .....	D7/664
D552,429 S *	10/2007	Onion .....	D7/649
D623,026 S *	9/2010	Gerlach .....	D7/649
D623,483 S *	9/2010	Gerlach .....	D7/649
D649,411 S *	11/2011	Lo .....	D7/649
D649,841 S *	12/2011	Lo .....	D7/649
D660,096 S *	5/2012	Chen .....	D7/649
D660,097 S *	5/2012	Chen .....	D7/649
D660,098 S *	5/2012	Chen .....	D7/649

\* cited by examiner

*Primary Examiner* — Ricky Pham

(74) *Attorney, Agent, or Firm* — Tutunjian & Bitetto, P.C.

(57) **CLAIM**

The ornamental design for a knife bolster, as shown and described.

**DESCRIPTION**

FIG. 1 is a perspective view of the knife bolster showing my new design;

FIG. 2 is a Left side view of the knife bolster showing my new design, the Right side view being a mirror view of the Left side;

FIG. 3 is a Top side view thereof;

FIG. 4 is a Bottom view thereof;

FIG. 5 is a Front view thereof; and,

FIG. 6 is a Rear view thereof.

The broken lines shown in the drawings are for illustrative purposes only and form no part of the claimed design.

**1 Claim, 2 Drawing Sheets**

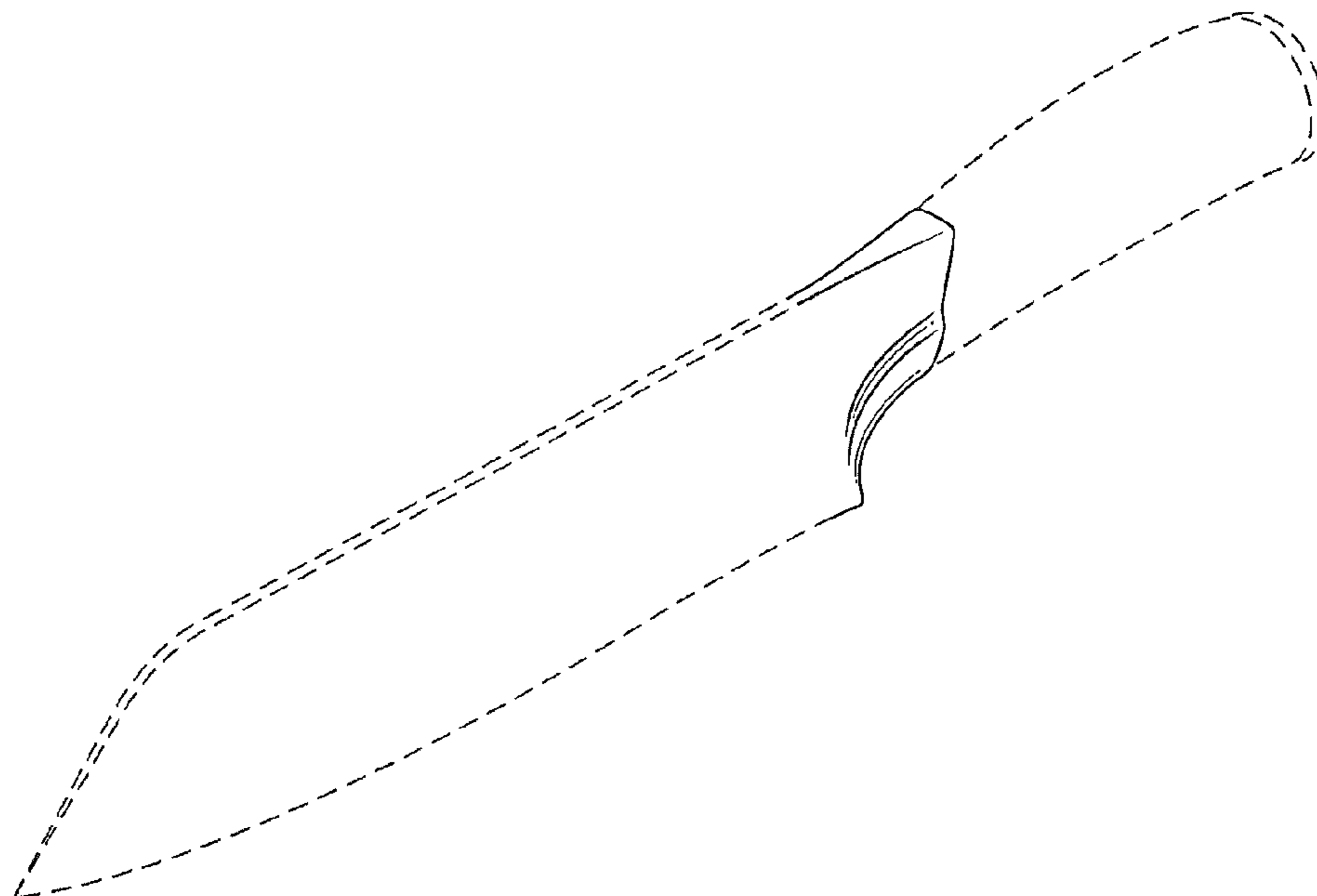

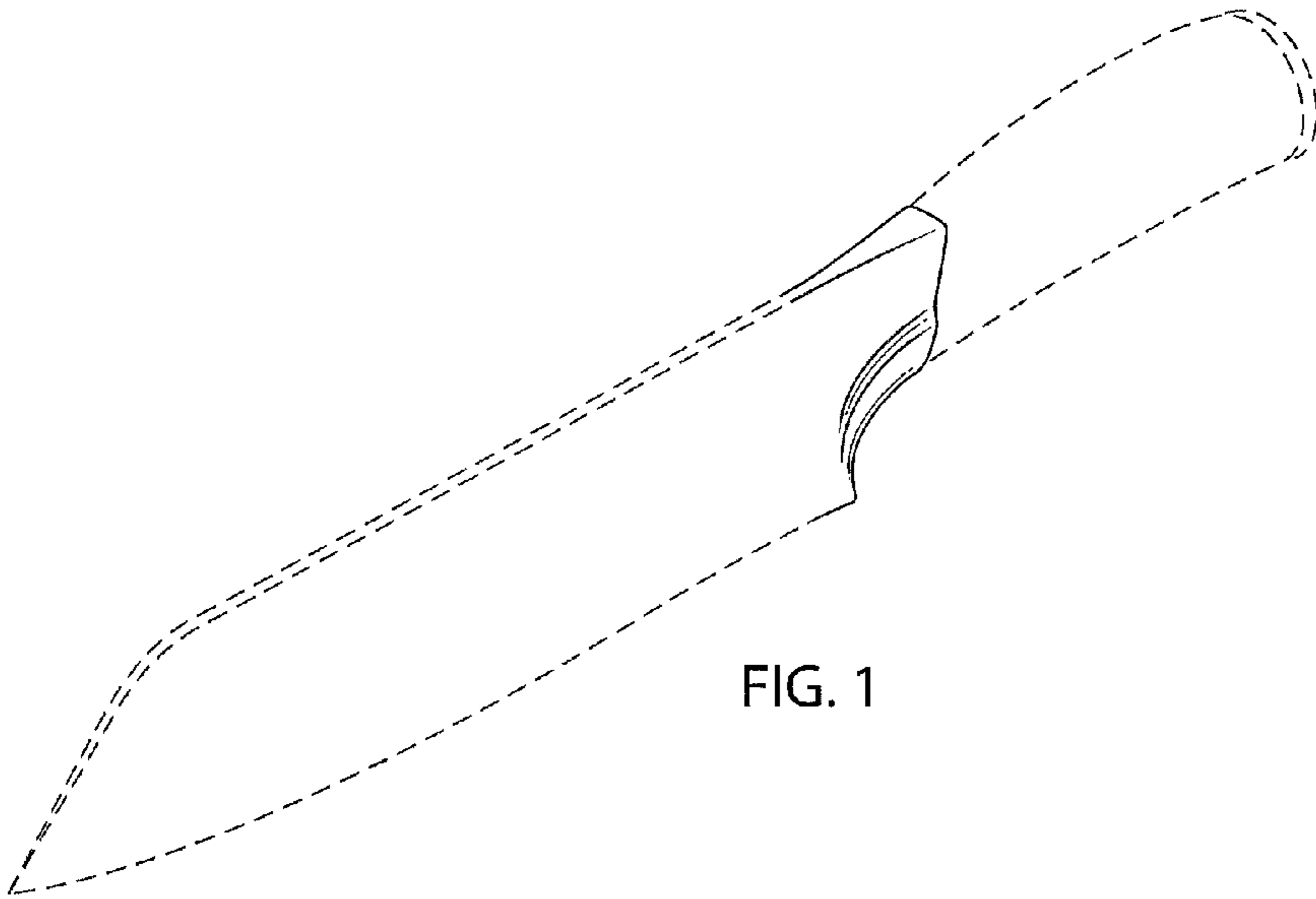

FIG. 1

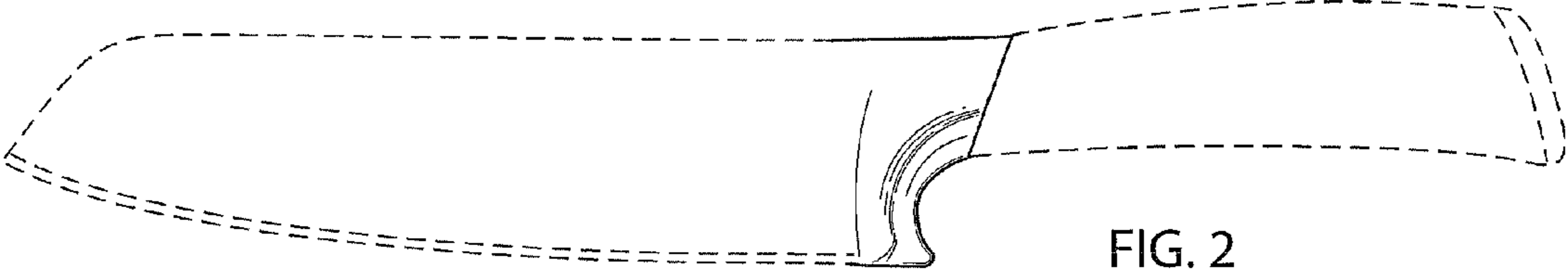

FIG. 2

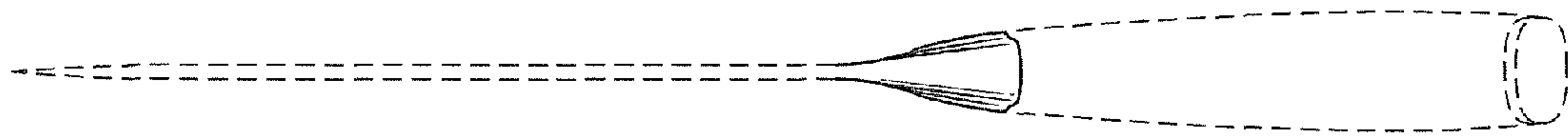

FIG. 3

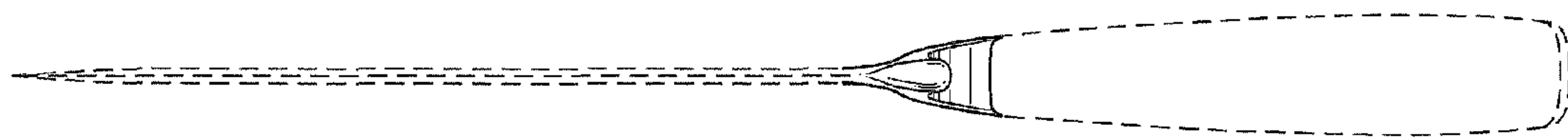

FIG. 4



FIG. 5

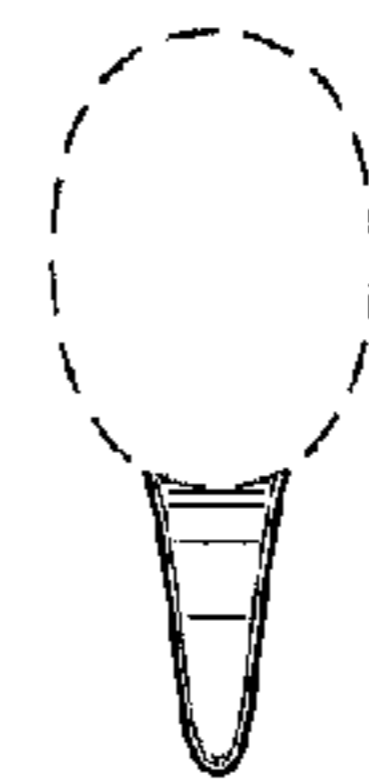

FIG. 6