



US00D720778S

(12) **United States Design Patent**
Lim et al.

(10) **Patent No.:** **US D720,778 S**
(45) **Date of Patent:** **** Jan. 6, 2015**

(54) **COMPRESSOR FOR VEHICLES**

(56) **References Cited**

(71) Applicant: **Halla Visteon Climate Control Corp.**,
Daedeok-gu, Daejeon (KR)

U.S. PATENT DOCUMENTS

(72) Inventors: **Kweon Soo Lim**, Daedeok-gu (KR); **Soo Cheol Jeong**, Daejeon (KR); **Chi Myeong Moon**, Daedeok-gu (KR); **In Guk Hwang**, Daejeon (KR)

D440,232 S *	4/2001	Kou	D15/9
D537,843 S *	3/2007	Chu	D15/9
D695,789 S *	12/2013	Nam	D15/9
D710,395 S *	8/2014	Park et al.	D15/9
D710,905 S *	8/2014	Park et al.	D15/9
D710,906 S *	8/2014	Park et al.	D15/9
D710,907 S *	8/2014	Lim et al.	D15/9
D710,908 S *	8/2014	Son et al.	D15/9
D710,909 S *	8/2014	Kim et al.	D15/9
D715,326 S *	10/2014	Lim et al.	D15/9
D715,327 S *	10/2014	Lim et al.	D15/9
D715,328 S *	10/2014	Kim et al.	D15/9

(73) Assignee: **Halla Visteon Climate Control Corp.**,
Daejeon (KR)

(**) Term: **14 Years**

* cited by examiner

(21) Appl. No.: **29/489,370**

Primary Examiner — Ralf Seifert

(22) Filed: **Apr. 29, 2014**

(74) *Attorney, Agent, or Firm* — Dickinson Wright PLLC

(30) **Foreign Application Priority Data**

(57) **CLAIM**

We claim the ornamental design for a compressor for vehicles, as shown herein.

Apr. 15, 2014 (KR) 30-2014-0018894

(51) **LOC (10) Cl.** **15-02**

(52) **U.S. Cl.**
USPC **D15/9**

(58) **Field of Classification Search**

CPC F01D 5/14; F01D 5/12; F01D 5/04;
F02B 33/40; F04D 29/42

USPC D15/7-9; D23/231, 232, 225; 417/60,
417/235, 265, 321, 355, 358, 363, 359,
417/410.1, 415-416, 405, 900, 231, 313,
417/273, 539; 60/408, 412; 184/26-37;
415/140-147; 123/495, 509; 418/259

See application file for complete search history.

DESCRIPTION

FIG. 1 is a perspective view of a compressor for vehicles according to the present design;
FIG. 2 is a front view of the compressor for vehicles according to the present design;
FIG. 3 is a rear view of the compressor for vehicles according to the present design;
FIG. 4 is a left side view of the compressor for vehicles according to the present design;
FIG. 5 is a right side view of the compressor for vehicles according to the present design;
FIG. 6 is a plan view of the compressor for vehicles according to the present design; and,
FIG. 7 is a bottom view of the compressor for vehicles according to the present design.

1 Claim, 7 Drawing Sheets

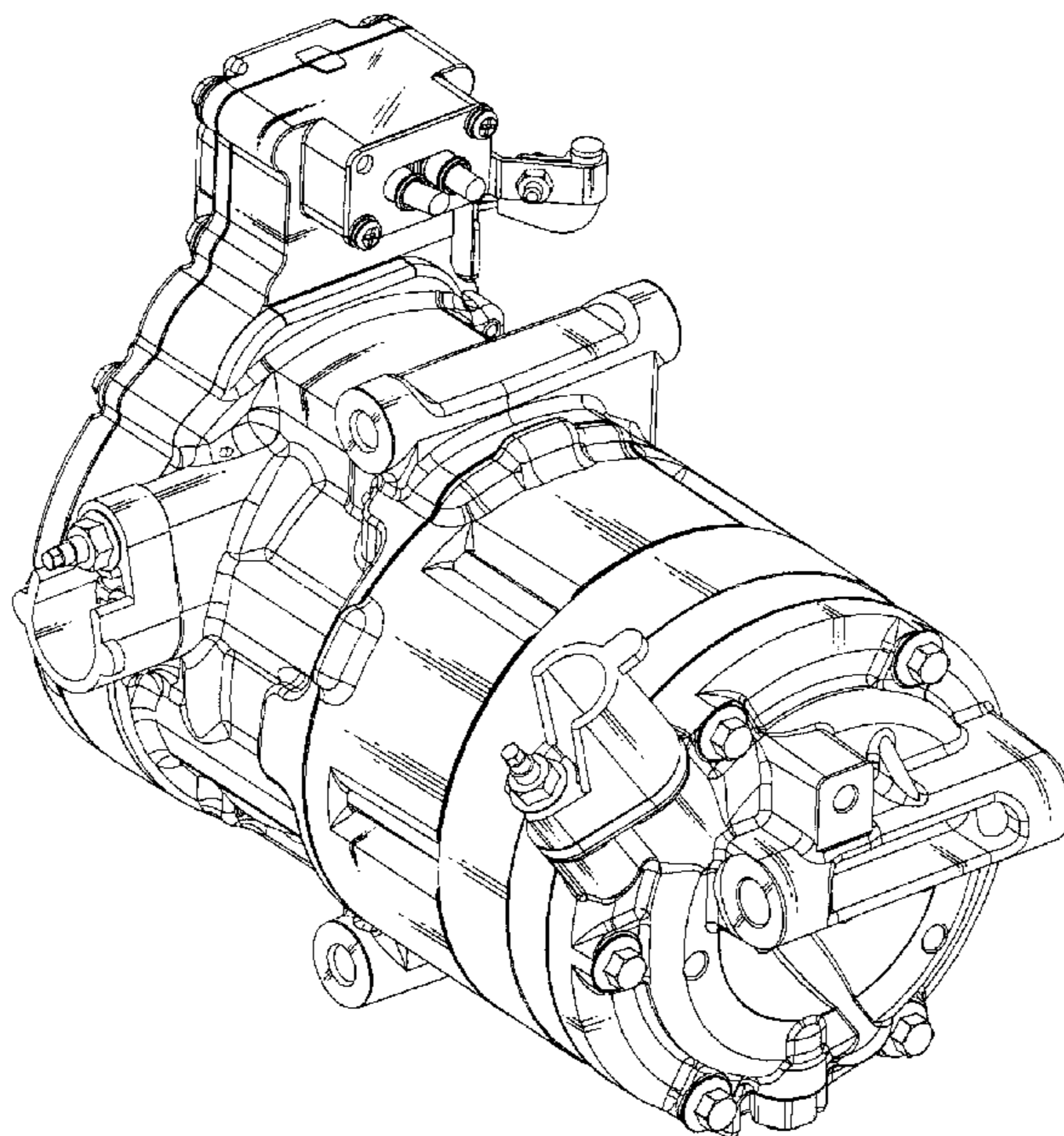

Fig. 1

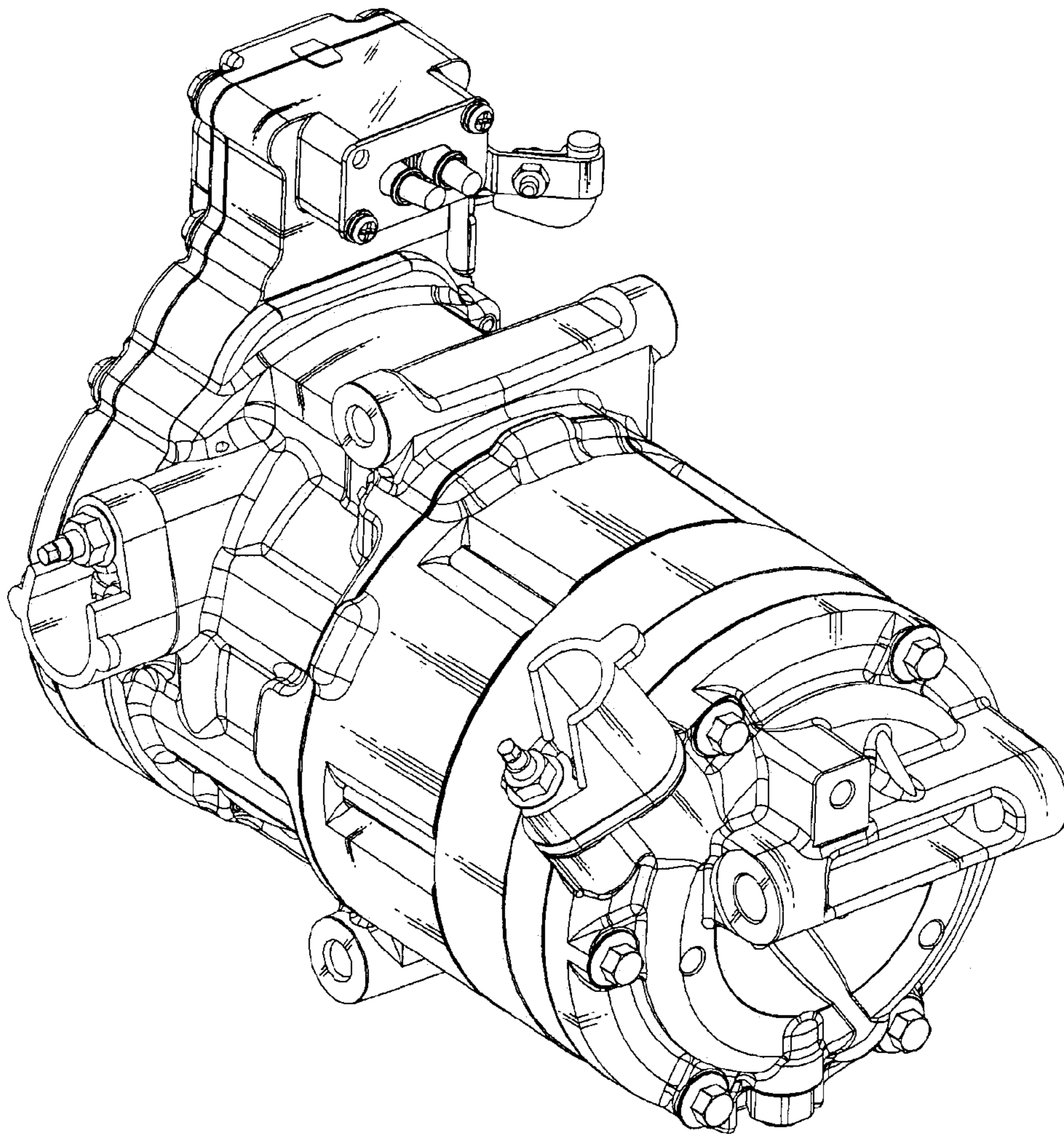

Fig. 2

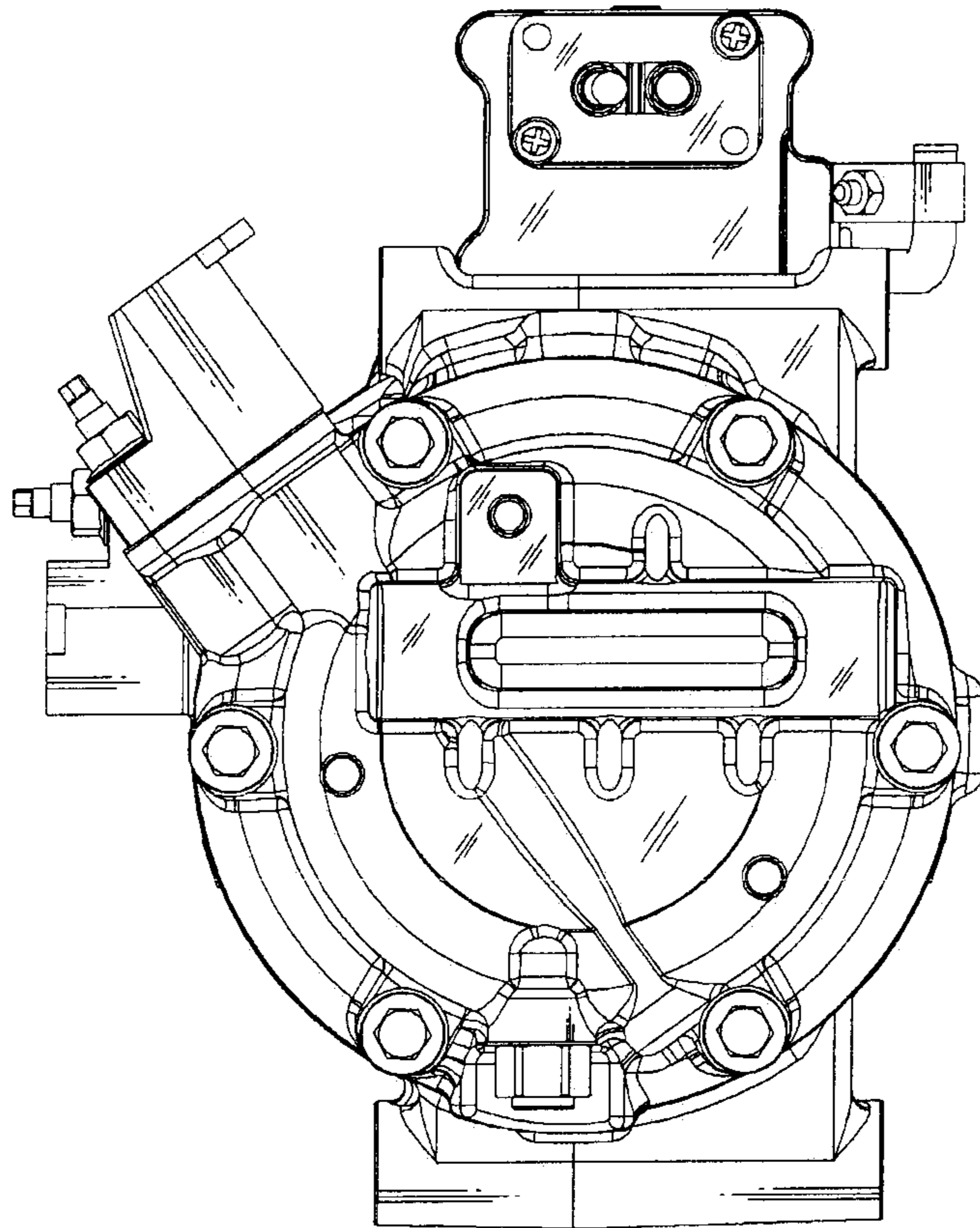

Fig. 3

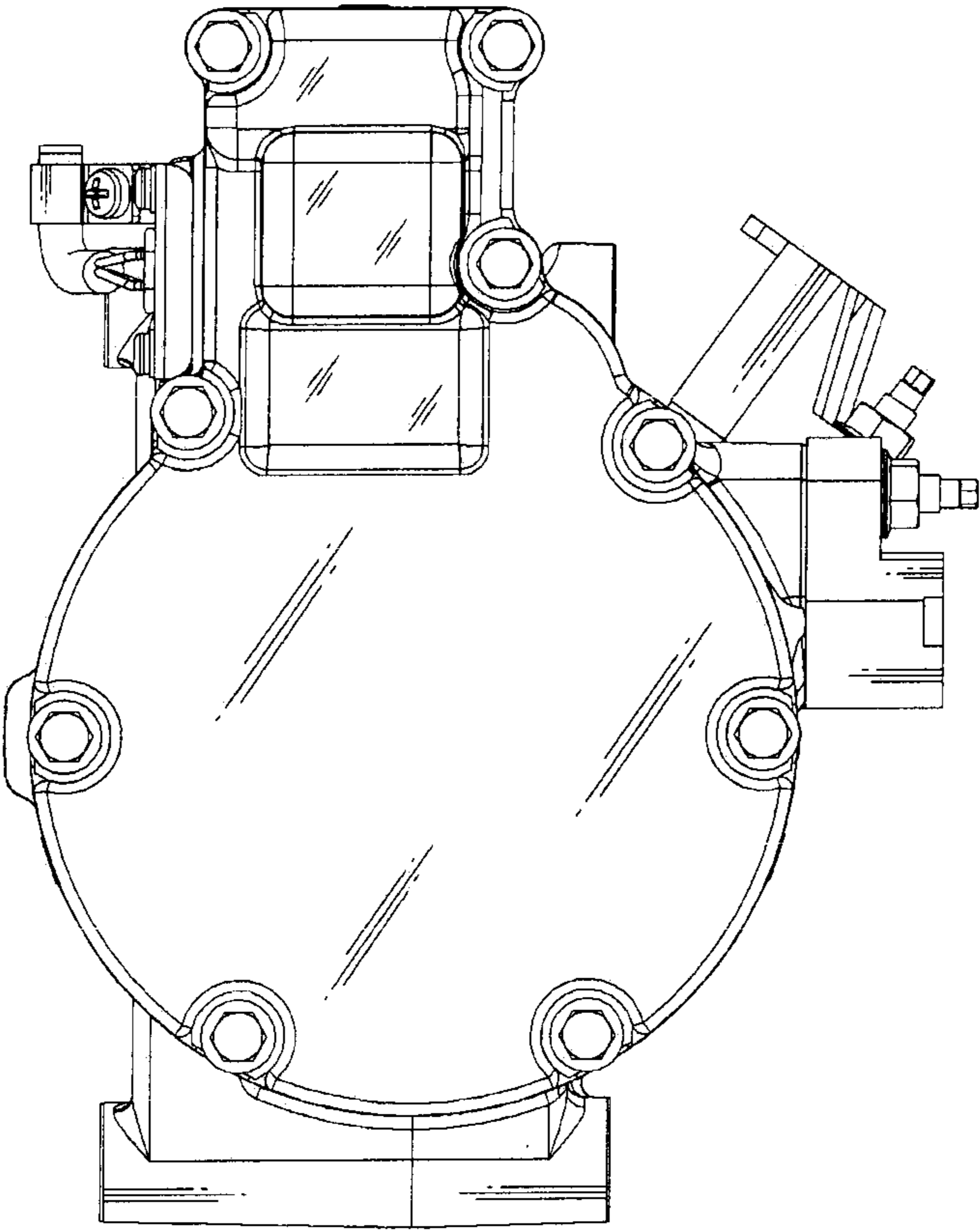

Fig. 4

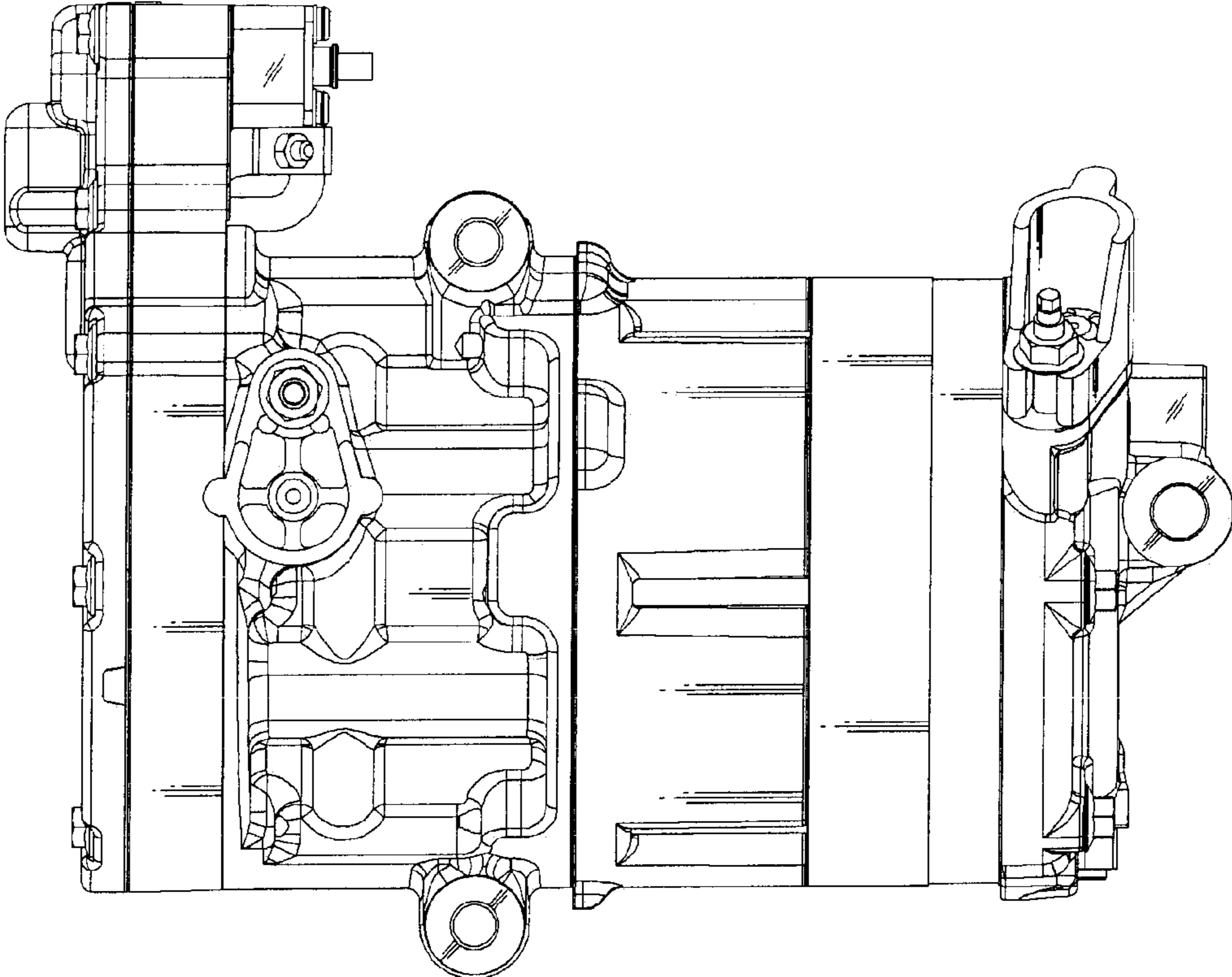

Fig. 5

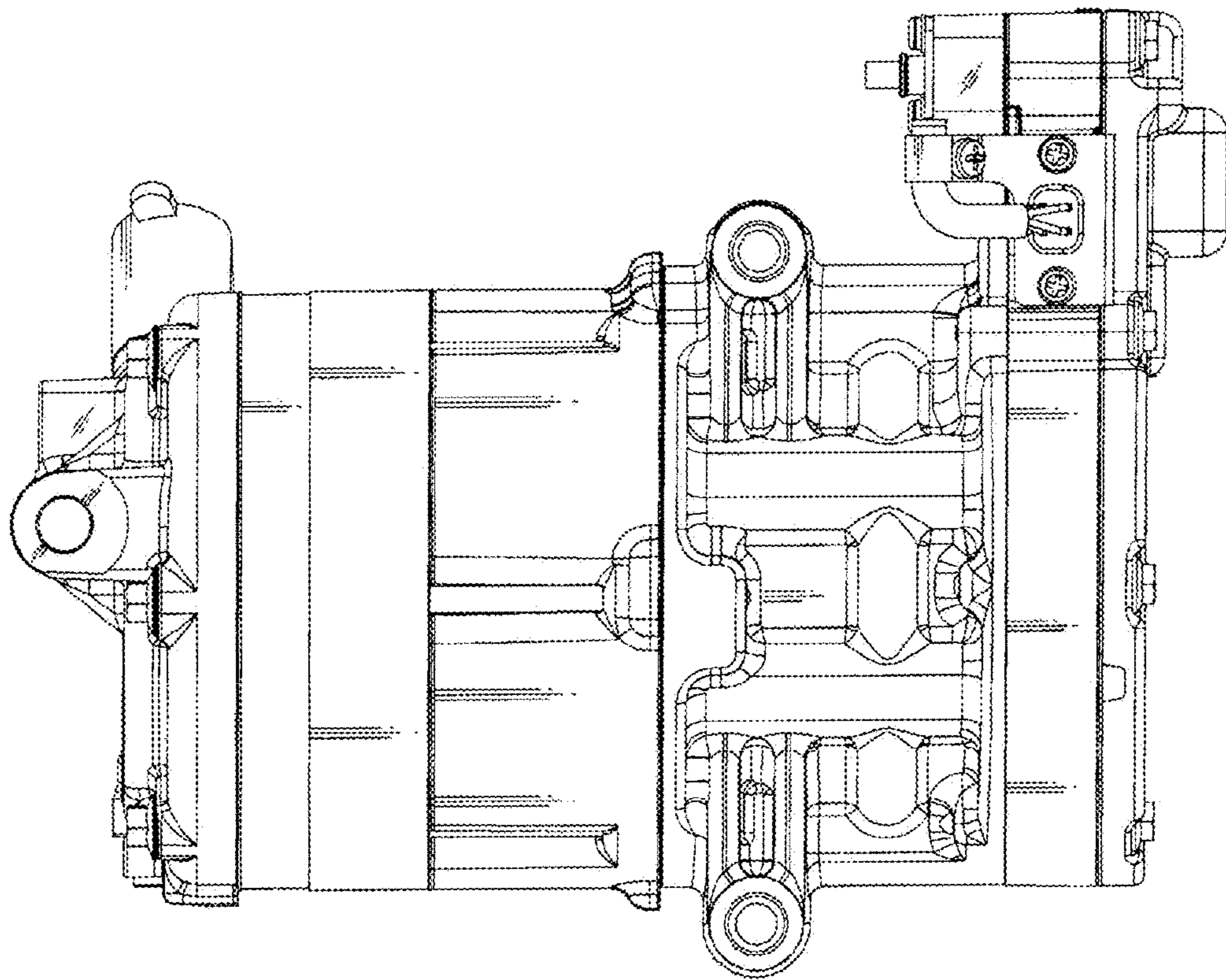

Fig. 6

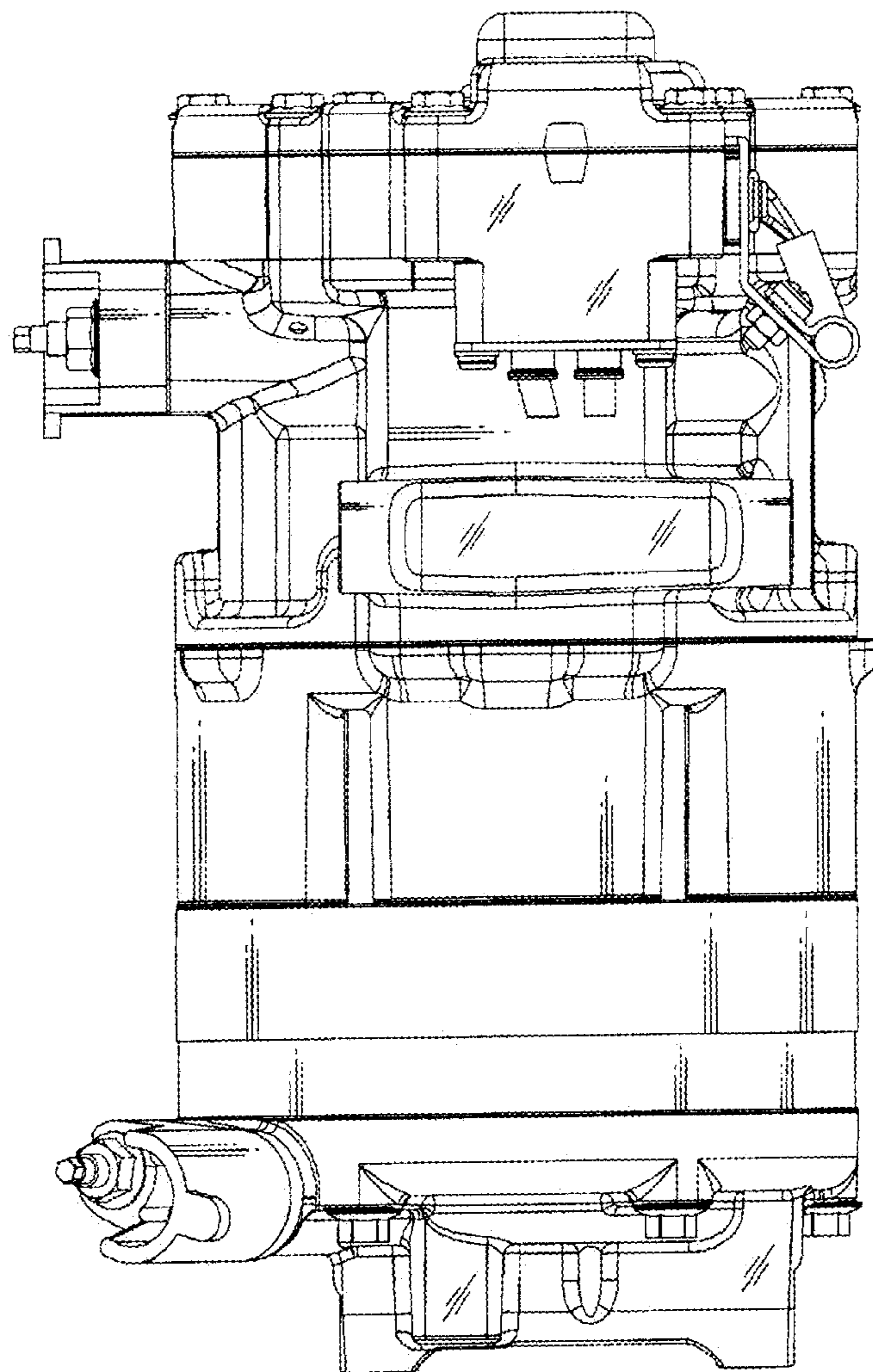

Fig. 7

