



US00D720281S

(12) **United States Design Patent Grant**

(10) **Patent No.:** **US D720,281 S**

(45) **Date of Patent:** **** Dec. 30, 2014**

(54) **CARGO CARRIER**

(71) Applicant: **Ricky Grant**, Mount Morris, MI (US)

(72) Inventor: **Ricky Grant**, Mount Morris, MI (US)

(**) Term: **14 Years**

(21) Appl. No.: **29/457,491**

(22) Filed: **Jun. 10, 2013**

(51) **LOC (10) Cl.** **12-99**

(52) **U.S. Cl.**
USPC **D12/414.1**

(58) **Field of Classification Search**
USPC D12/414.1, 414, 413, 412, 221, 406,
D12/157, 423; D6/552, 317-319, 513-514;
D3/304-306; 293/37.1, 3, 100;
296/39.1, 39.2, 37.6, 26.09, 99.1,
296/100.02, 157; 220/771; 224/309-311,
224/323-329, 273, 42.42, 400-404, 539,
224/542, 315-317, 510, 543, 544, 924;
414/462; 280/848, 727, 769; 206/213,
206/8, 9, 279, 290, 713, 335, 315.1-315.4;
32/35, 58

See application file for complete search history.

(56) **References Cited**

U.S. PATENT DOCUMENTS

4,260,091	A *	4/1981	French et al.	224/311
D274,139	S *	6/1984	Suffern et al.	D12/414.1
5,226,302	A *	7/1993	Anderson	70/159
D430,103	S *	8/2000	Scudder	D12/414.1
6,507,701	B2 *	1/2003	Lake	296/37.6
D658,373	S *	5/2012	Gros	D3/273

D659,632	S *	5/2012	Jordan	D12/414.1
D660,781	S *	5/2012	Ruffino et al.	D12/414.1
2002/0175530	A1 *	11/2002	Lake	296/37.6
2007/0119093	A1 *	5/2007	Jaskulski	43/54.1
2008/0264946	A1 *	10/2008	Moschella et al.	220/326
2009/0056592	A1 *	3/2009	Threet et al.	108/11
2014/0062042	A1 *	3/2014	Wagner et al.	280/30

* cited by examiner

Primary Examiner — Katrina A Betton

(74) *Attorney, Agent, or Firm* — QuickPatents; Kevin Prince

(57) **CLAIM**

I claim the ornamental design for a cargo carrier, as shown and described.

DESCRIPTION

FIG. 1 is a perspective view of a cargo carrier, showing my new design in an open position;
 FIG. 2 is an enlarged perspective view thereof, illustrated in a closed position;
 FIG. 3 is a front elevational view of FIG. 2;
 FIG. 4 is a rear elevational view of FIG. 2;
 FIG. 5 is a left-side elevational view of FIG. 2;
 FIG. 6 is a right-side elevational view of FIG. 2;
 FIG. 7 is a top plan view of FIG. 2; and,
 FIG. 8 is a bottom plan view of FIG. 2.

In the drawing figures the broken lines on the cargo carrier indicate stitching. The broken lines in FIG. 1 depict a truck and items stored in the cargo carrier that form no part of the claimed design.

1 Claim, 3 Drawing Sheets

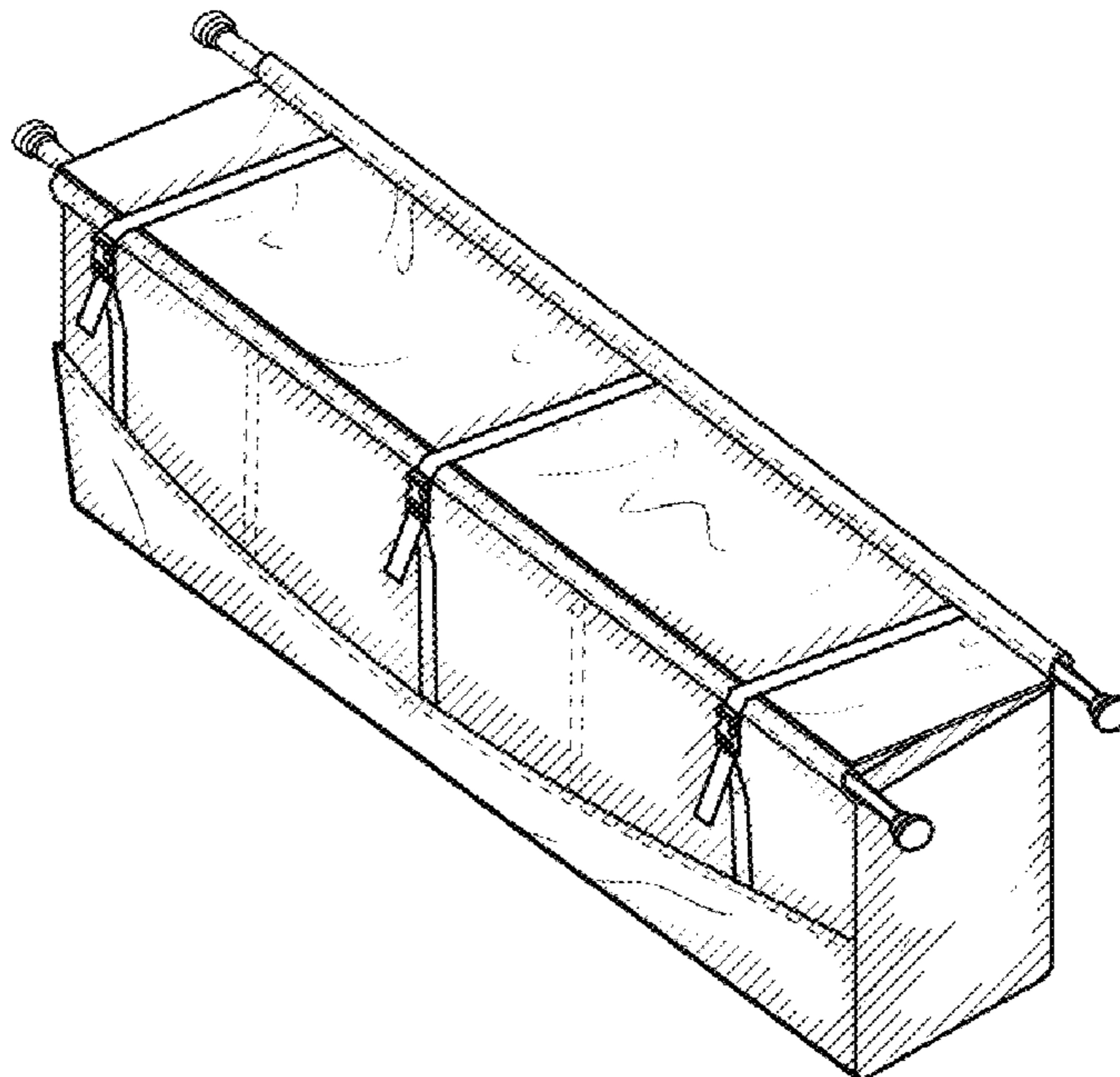

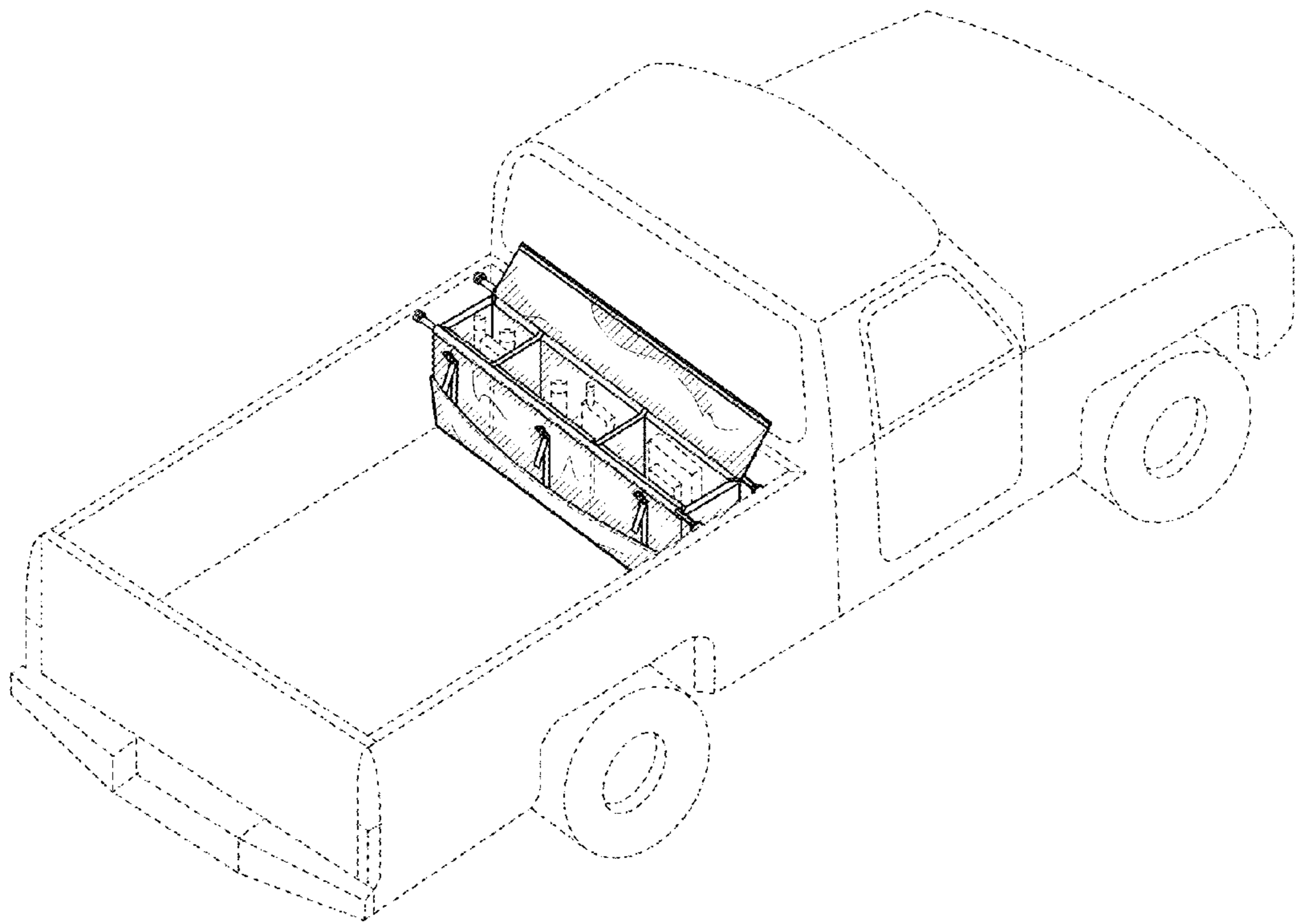

FIG. 1

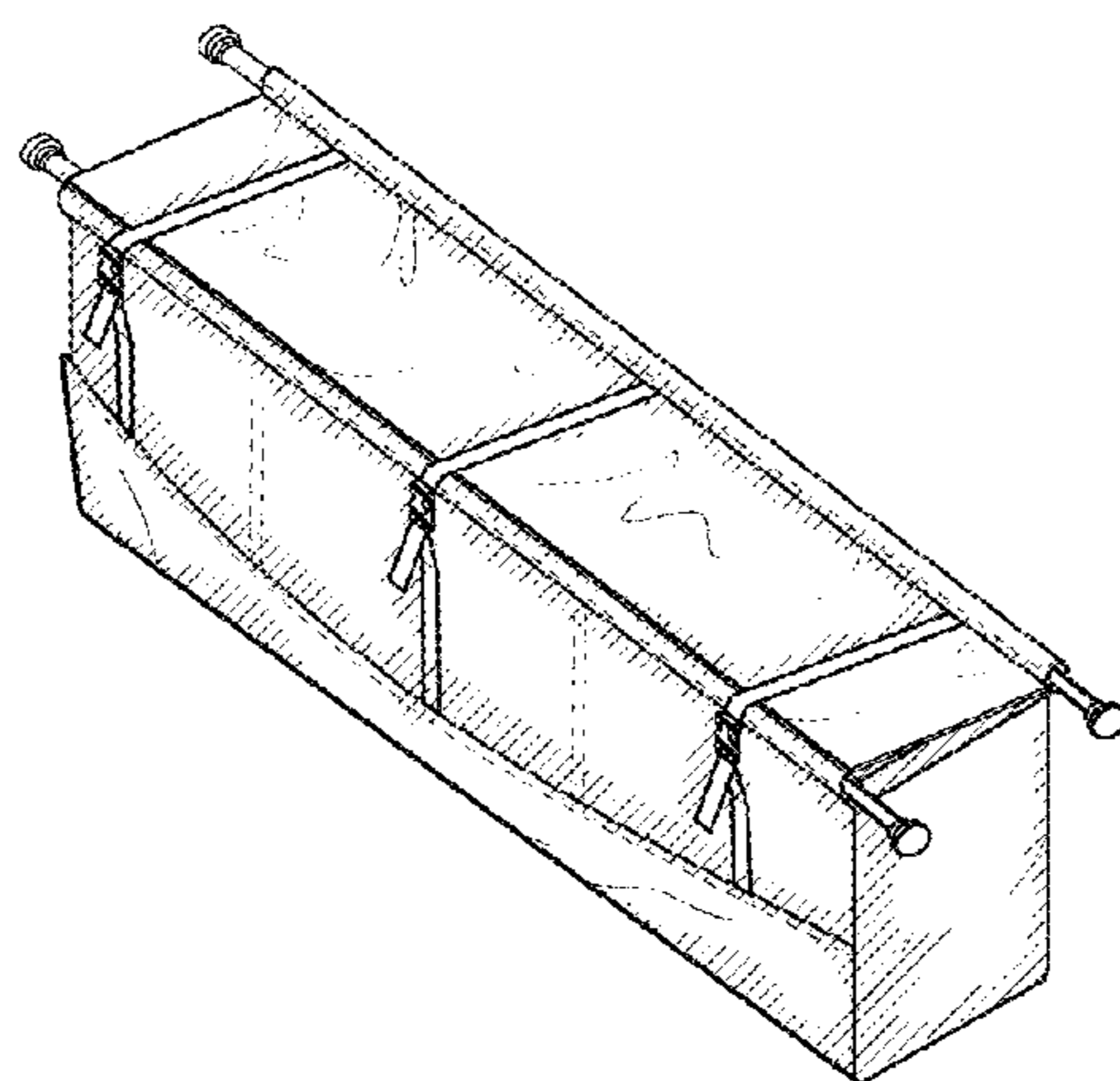

FIG. 2

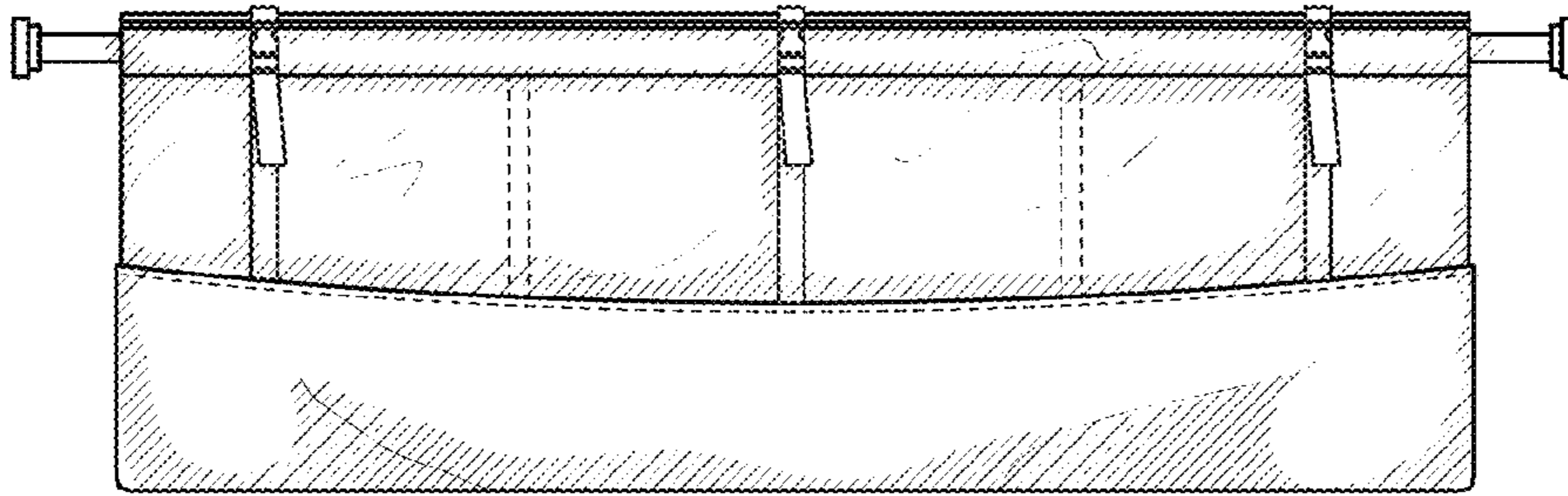

FIG. 3

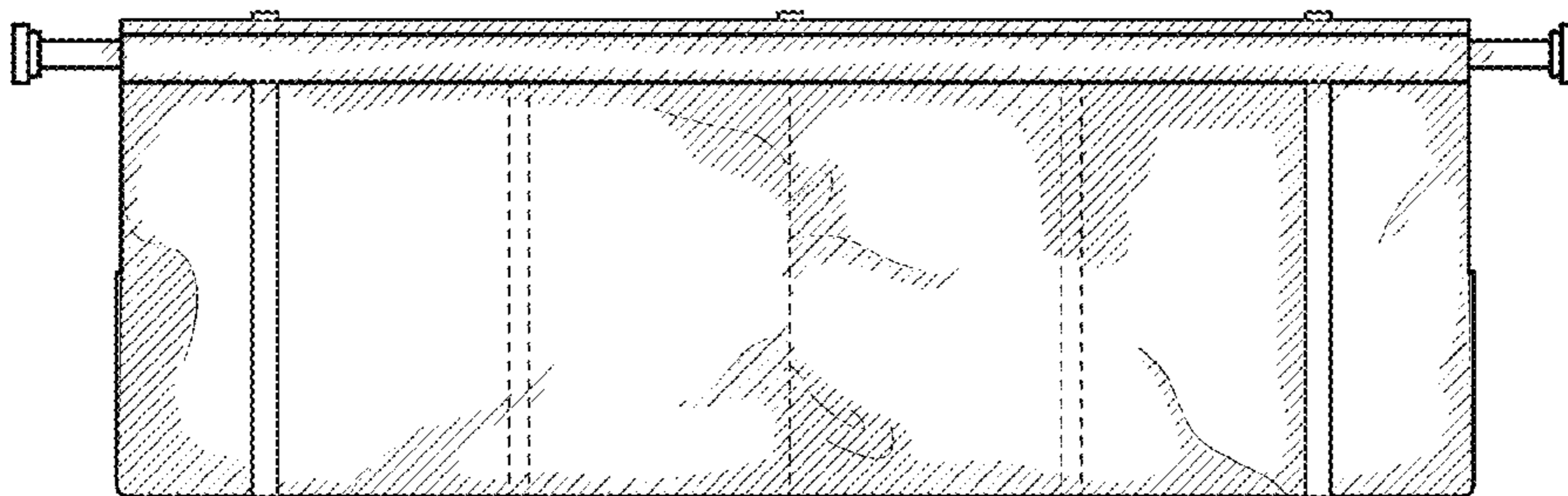

FIG. 4

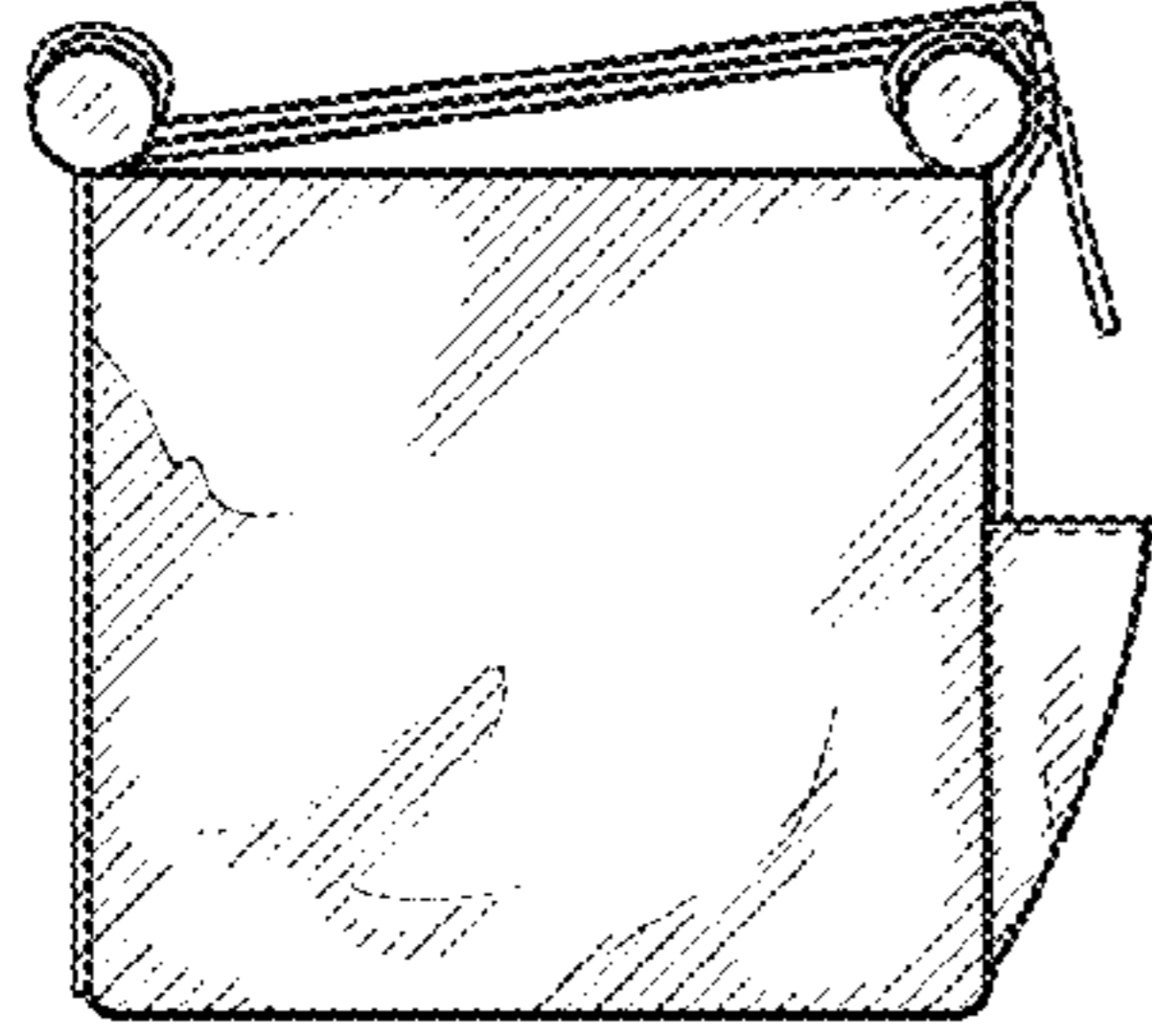

FIG. 5

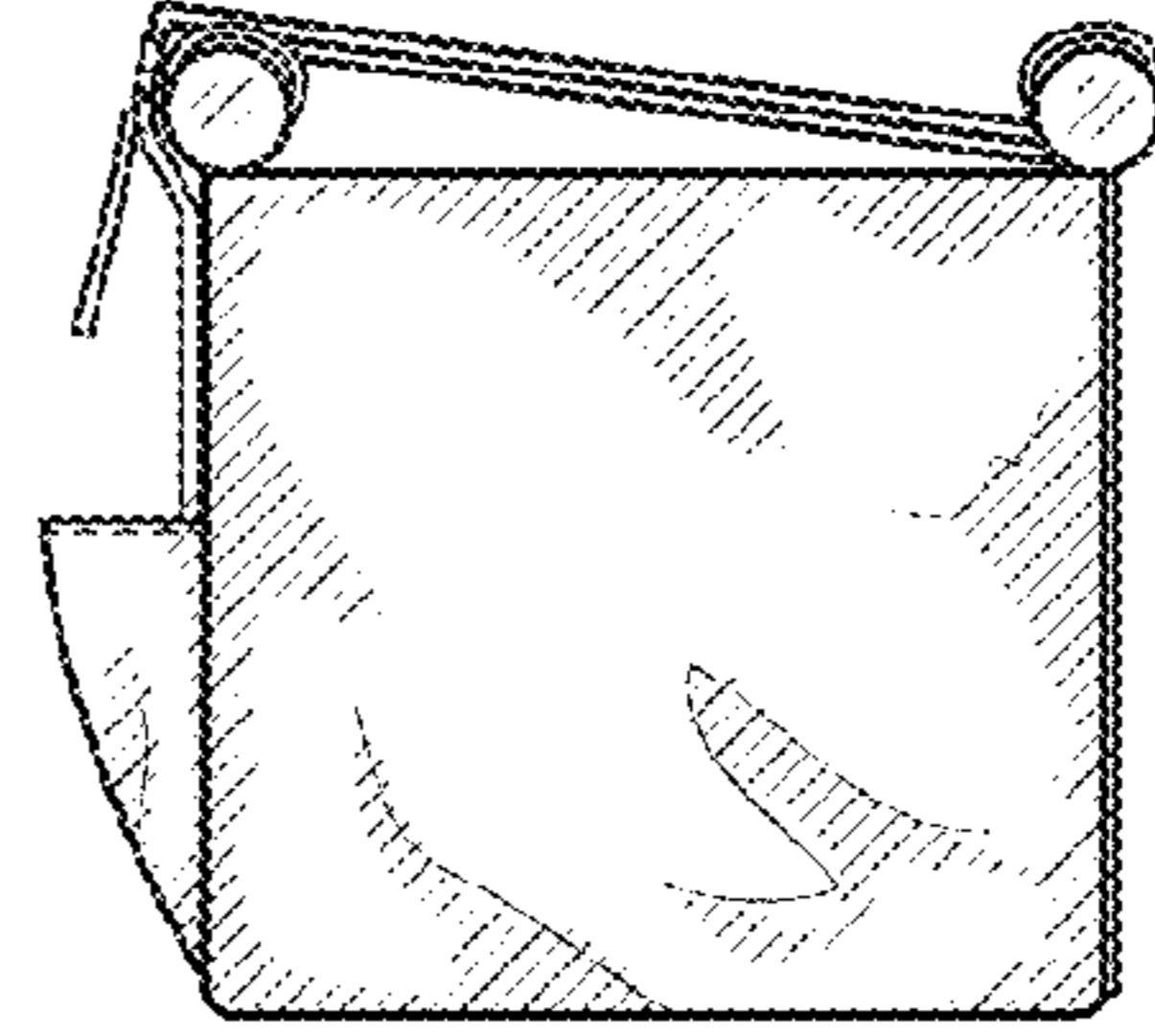

FIG. 6

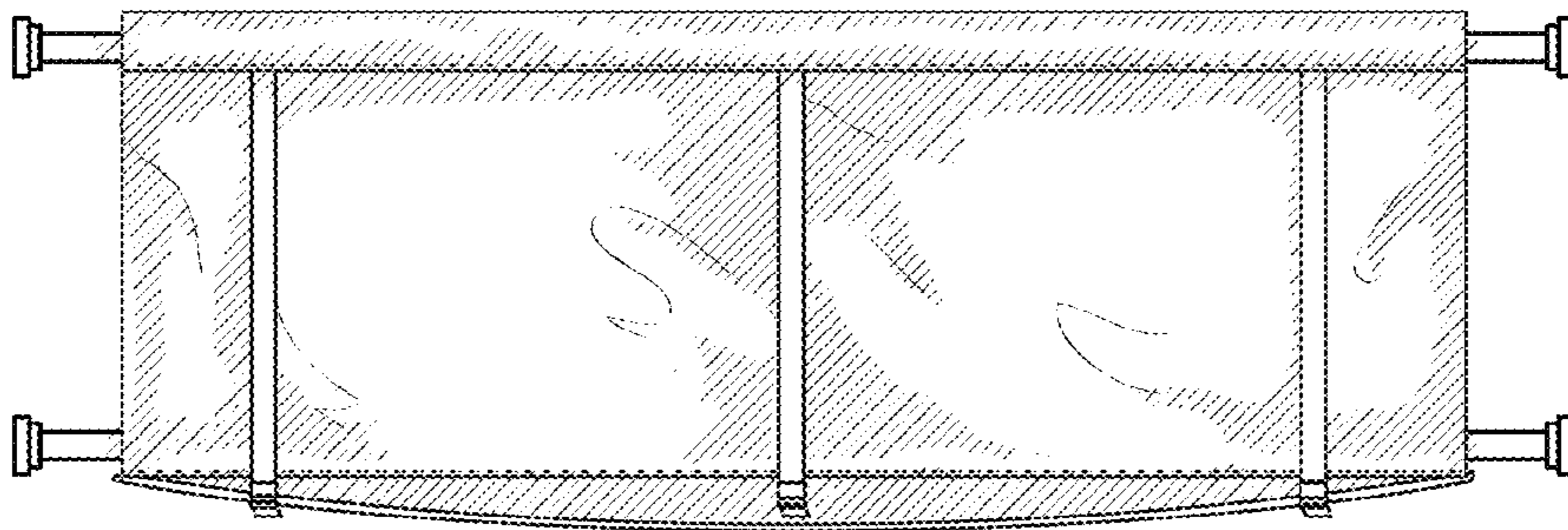

FIG. 7

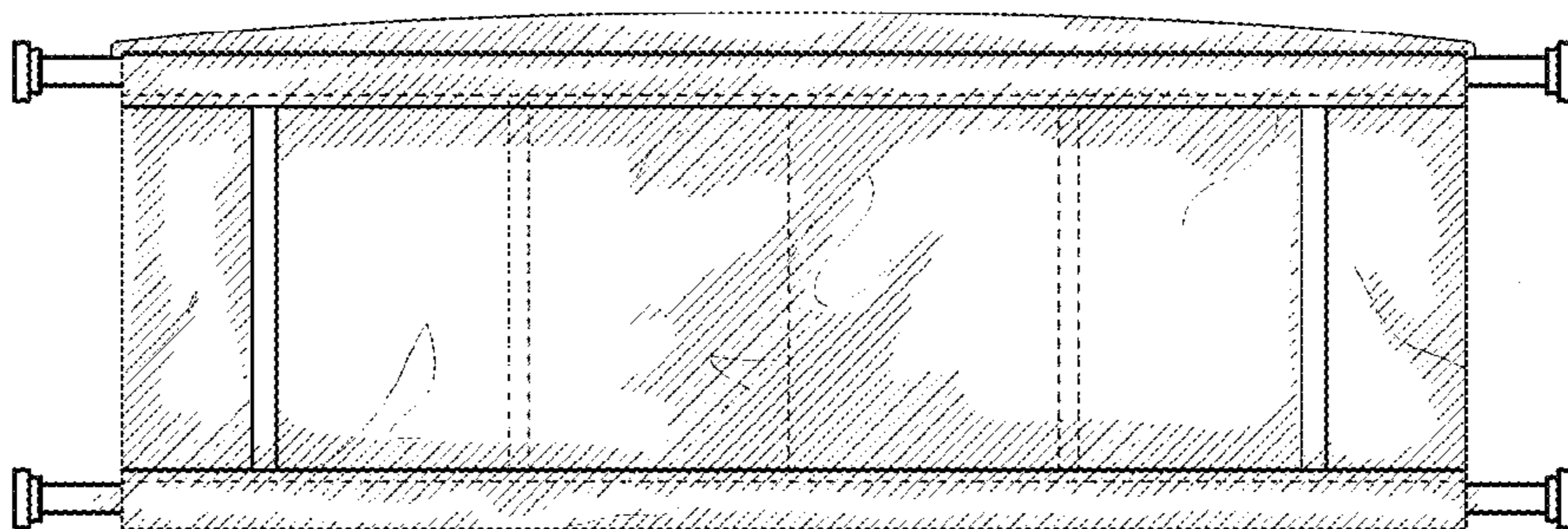

FIG. 8