

US00D720052S

(12) **United States Design Patent**  
**Roberts et al.**

(10) **Patent No.:** **US D720,052 S**

(45) **Date of Patent:** **\*\* Dec. 23, 2014**

(54) **REFRIGERANT DISTRIBUTOR**

(71) Applicant: **Parker-Hannifin Corporation**,  
Cleveland, OH (US)

(72) Inventors: **Timothy J Roberts**, Eureka, MO (US);  
**Donald Staten**, Chesterfield, MO (US);  
**Joseph Arens**, St. Charles, MO (US)

(73) Assignee: **Parker-Hannifin Corporation**,  
Cleveland, OH (US)

(\*\*) Term: **14 Years**

(21) Appl. No.: **29/491,562**

(22) Filed: **May 22, 2014**

(51) **LOC (10) Cl.** ..... **23-01**

(52) **U.S. Cl.**

USPC ..... **D23/266**

(58) **Field of Classification Search**

USPC ..... D15/1-6; 285/305, 319, 125.1, 131.1,  
285/124.1, 124.5, 321, 93; D23/259, 262,  
D23/213, 214, 233, 266

See application file for complete search history.

(56) **References Cited**

**U.S. PATENT DOCUMENTS**

2,082,403	A *	6/1937	Larkin	.....	138/37
2,803,116	A	8/1957	Tilney		
4,284,243	A *	8/1981	Shaner	.....	239/469
4,319,772	A *	3/1982	Weirich et al.	.....	285/26
D353,443	S *	12/1994	Lopez	.....	D23/259
7,174,726	B2 *	2/2007	Grau et al.	.....	62/115
D643,932	S *	8/2011	Vogtner et al.	.....	D24/201
8,210,574	B2	7/2012	Shimaoka et al.		
8,500,171	B2 *	8/2013	Tadlock et al.	.....	285/125.1
2007/0266730	A1	11/2007	Son et al.		
2009/0000286	A1 *	1/2009	Aoki et al.	.....	60/323

2010/0170584	A1 *	7/2010	Chung et al.	.....	137/561 A
2010/0293980	A1 *	11/2010	Shimaoka et al.	.....	62/259.1
2012/0210744	A1	8/2012	Nelson		

**OTHER PUBLICATIONS**

“Refrigerant Distributors”, BHM Corporation, [retrieved online May 12, 2014], <<http://www.bhmcorp.co.in/refrigerant-distributors.html>>.

“Liquid Distributor Type RD”, Danfoss, copyright 2013.

“Venturi-Flo Low Pressure Drop Distributors”, KeepFlo, Control Devices, LLC., at least as early as May 12, 2014.

“Brass Refrigerant Distributors”, Spinco Metal Products, Inc., [retrieved online May 12, 2014], <<http://spincometal.com/products/refrigerant-distributors/>>.

\* cited by examiner

*Primary Examiner* — T. Chase Nelson

*Assistant Examiner* — Ania Aman

(74) *Attorney, Agent, or Firm* — Renner, Otto, Boisselle & Sklar, LLP

(57) **CLAIM**

The ornamental design for a refrigerant distributor, as shown and described.

**DESCRIPTION**

FIG. 1 is a perspective view of a refrigerant distributor showing our new design.

FIG. 2 is another perspective view thereof.

FIG. 3 is a front view thereof.

FIG. 4 is a rear view thereof.

FIG. 5 is a top view thereof, a bottom view being a mirror image of the top view; and,

FIG. 6 is a left side view thereof, a right side view being a mirror image of the left side view.

The broken lines shown herein are for illustrative purposes only and form no part of the claimed design.

**1 Claim, 5 Drawing Sheets**

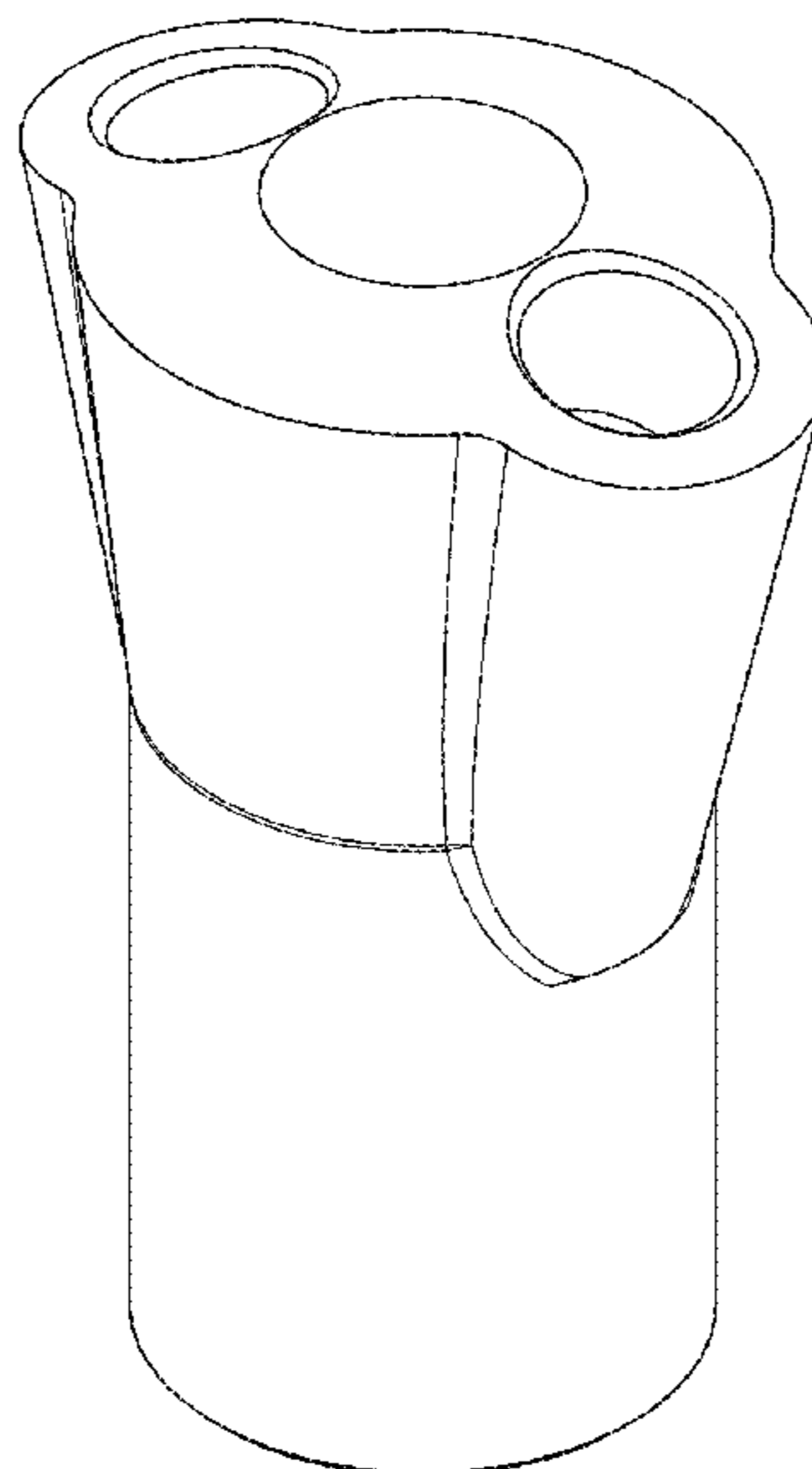

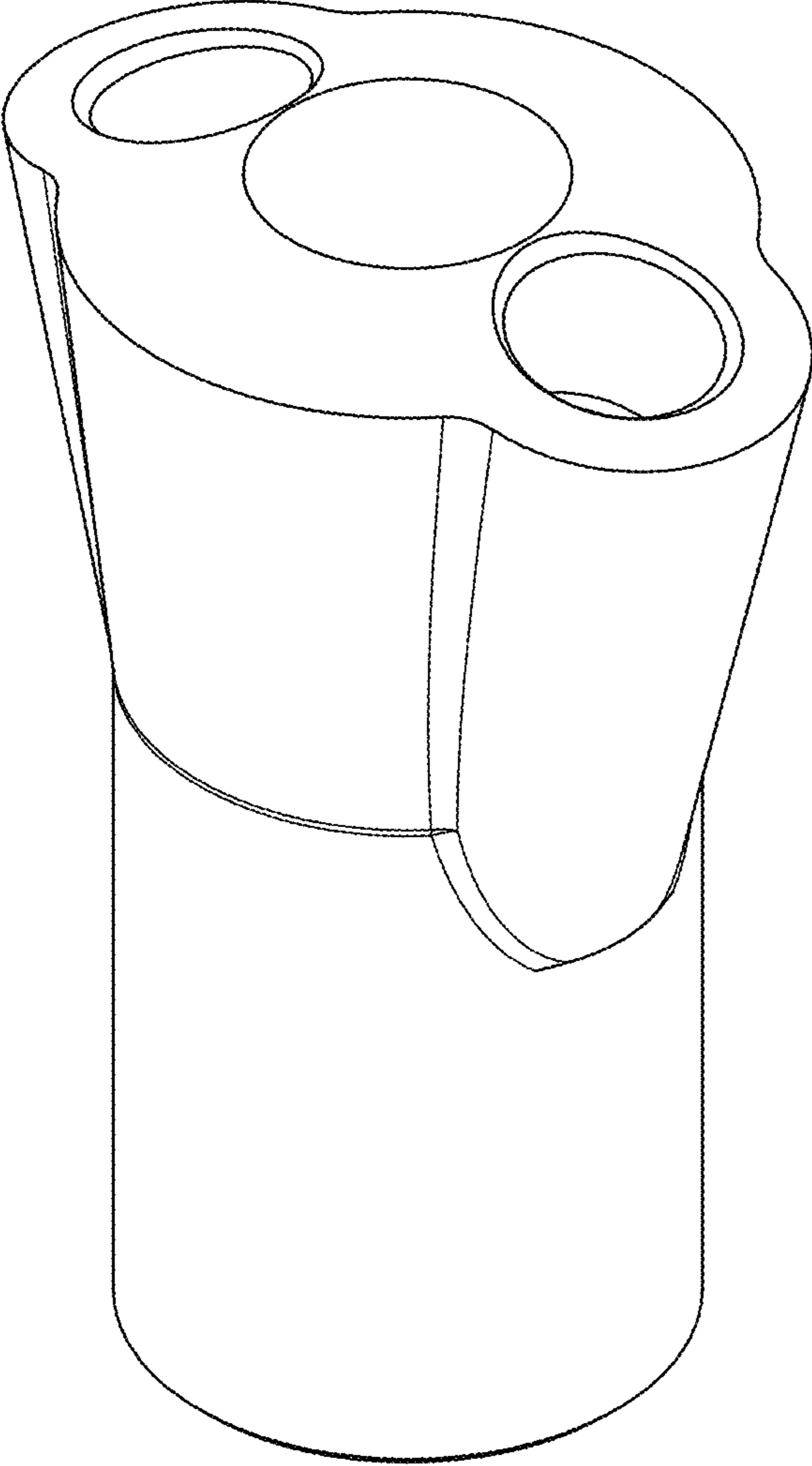

FIG. 1

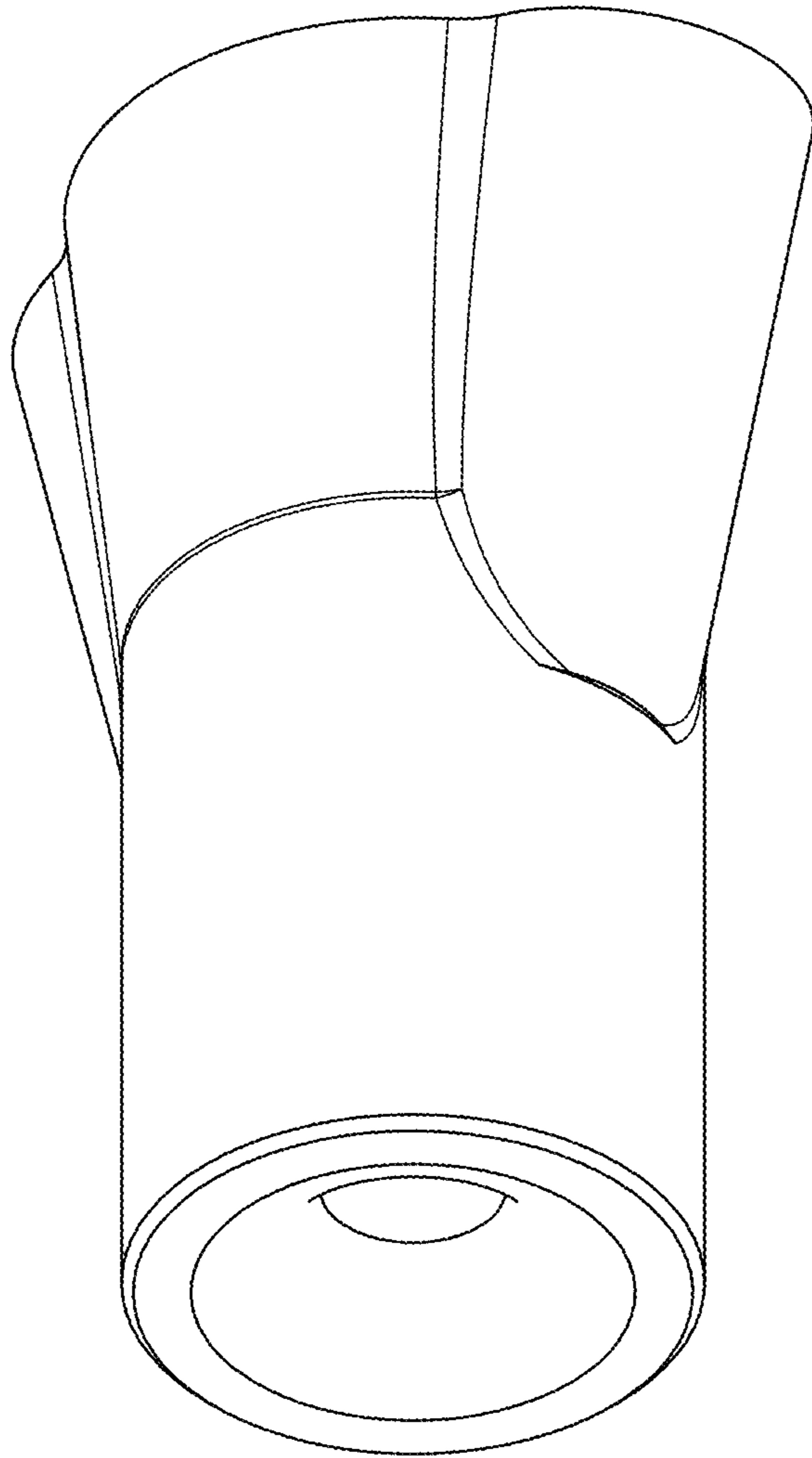

FIG. 2

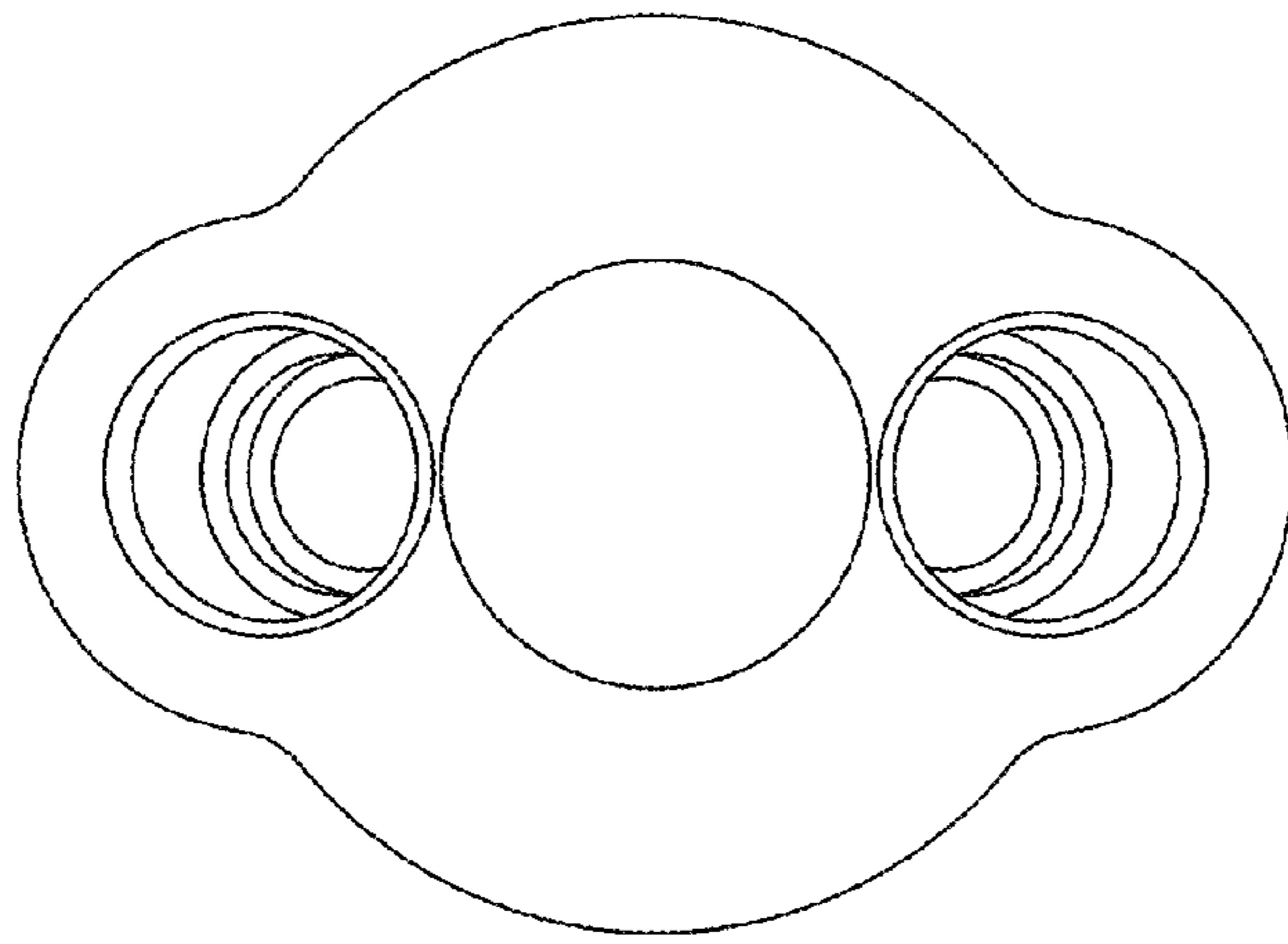

FIG. 3

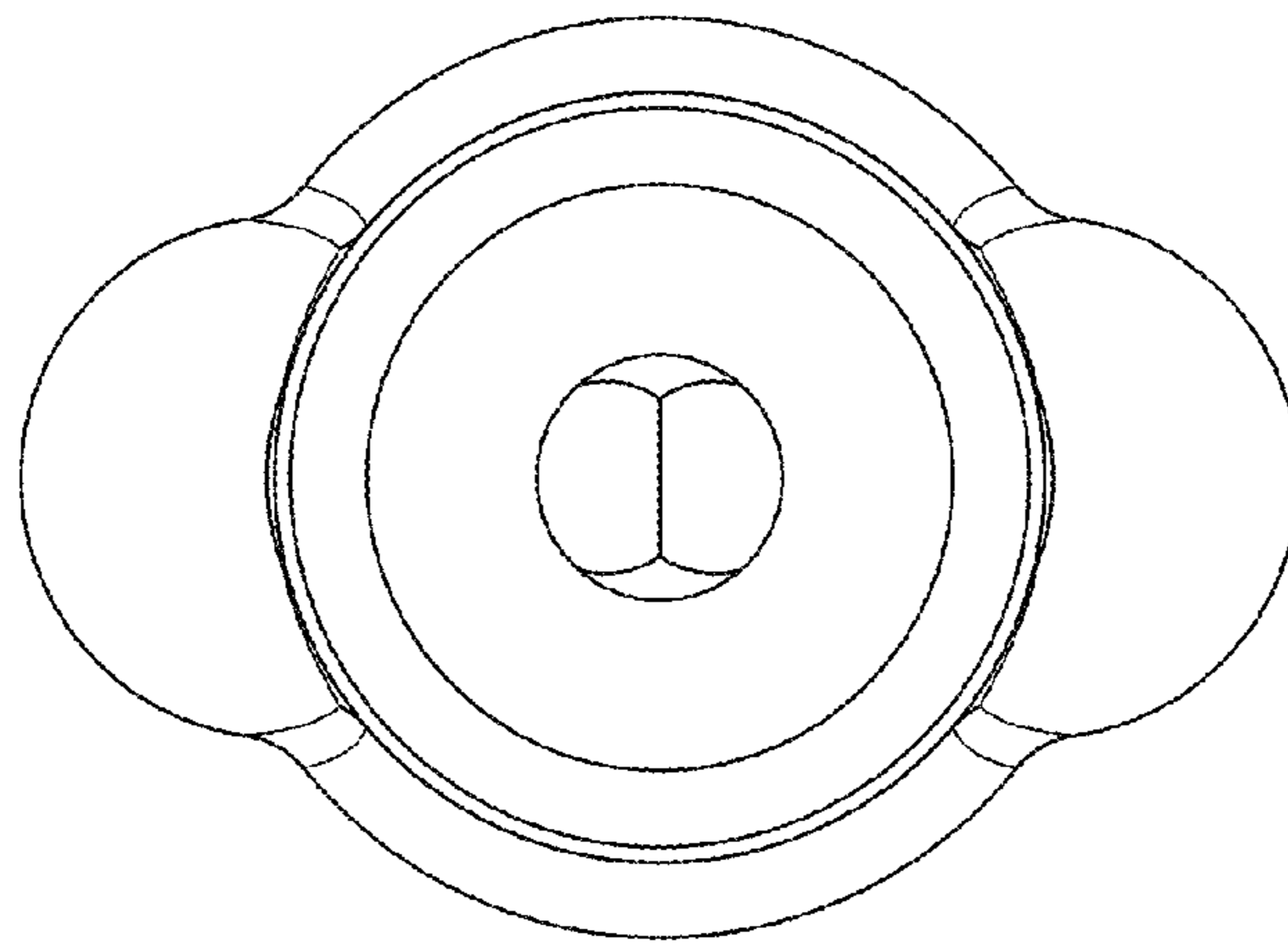

FIG. 4

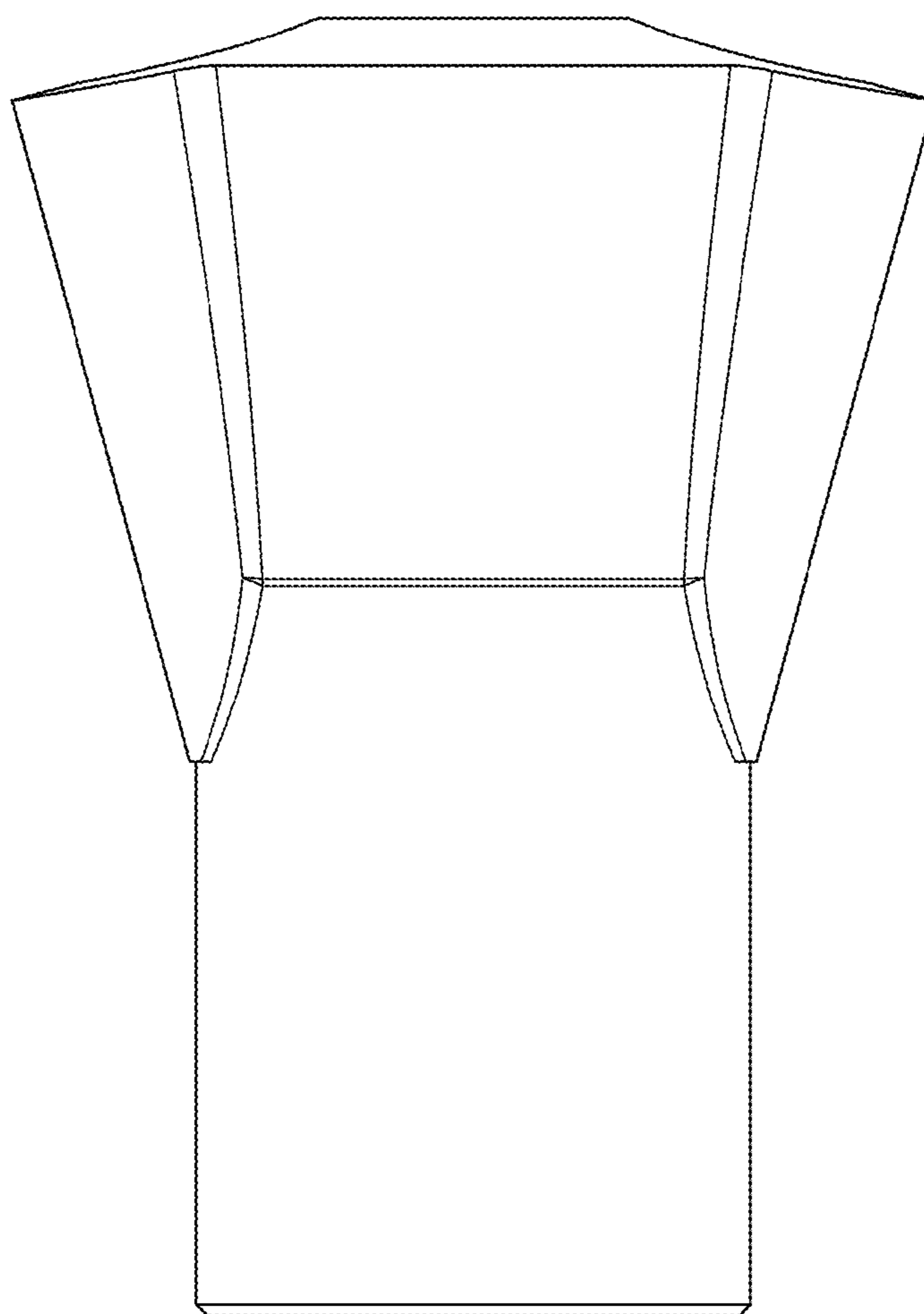

FIG. 5

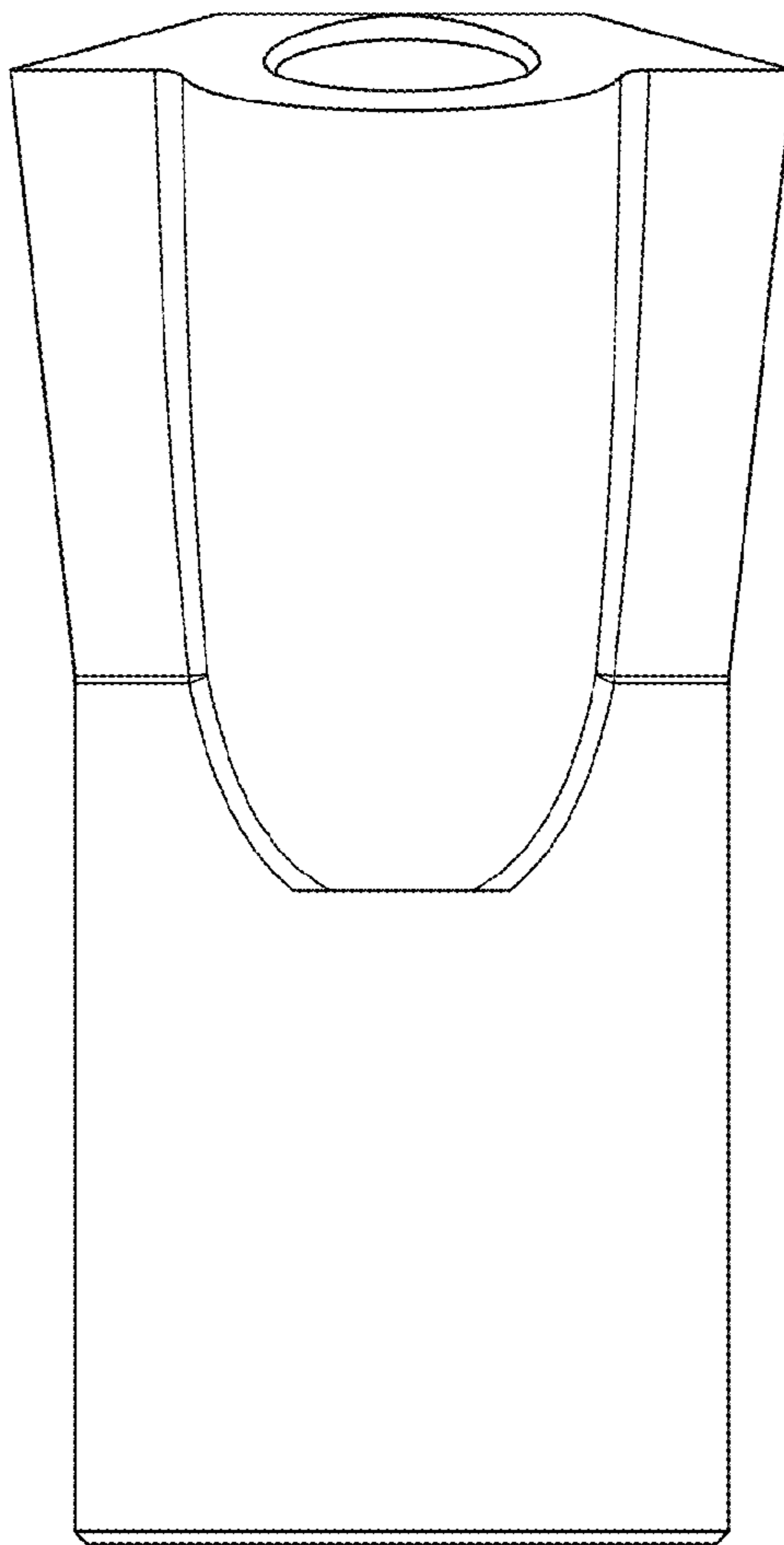

FIG. 6