



US00D719689S

(12) **United States Design Patent**
Gotschke

(10) **Patent No.:** **US D719,689 S**

(45) **Date of Patent:** **** Dec. 16, 2014**

(54) **VEHICLE HEADLIGHT**

(75) Inventor: **Wolfgang Gotschke**, Cologne (DE)

(73) Assignee: **Ford Motor Company**, Dearborn, MI (US)

(**) Term: **14 Years**

(21) Appl. No.: **29/429,681**

(22) Filed: **Aug. 15, 2012**

(51) **LOC (10) Cl.** **26-06**

(52) **U.S. Cl.**
USPC **D26/28**

(58) **Field of Classification Search**
USPC D26/28-36; 362/459-468, 475-478,
362/485-487
See application file for complete search history.

(56) **References Cited**

U.S. PATENT DOCUMENTS

D528,681 S *	9/2006	Nakahara	D26/28
D528,685 S *	9/2006	Yoshida	D26/28
D544,114 S *	6/2007	Ohta	D26/28
D544,614 S *	6/2007	Markefka	D26/28
D549,857 S *	8/2007	Lin	D26/28
D561,358 S *	2/2008	Tachibana	D26/28
D606,678 S	12/2009	George		
D619,279 S	7/2010	Lamm		

* cited by examiner

Primary Examiner — Marcus Jackson

(74) *Attorney, Agent, or Firm* — Damian Porcari

(57) **CLAIM**

The ornamental design for a vehicle headlight, shown and described.

DESCRIPTION

FIG. 1 is a left side elevational view of a left vehicle headlight, (the right vehicle headlight being a mirror image and is not shown);

FIG. 2 is a right side elevational view thereof;
 FIG. 3 is a front elevational view thereof;
 FIG. 4 is a rear elevational view thereof;
 FIG. 5 is a top plan view thereof;
 FIG. 6 is a bottom plan view thereof;
 FIG. 7 is a perspective view thereof;
 FIG. 8 is a another perspective view thereof;
 FIG. 9 is a left side elevational view of a second embodiment thereof;
 FIG. 10 is a right side elevational view thereof;
 FIG. 11 is a front elevational view thereof;
 FIG. 12 is a rear elevational view thereof;
 FIG. 13 is a top plan view thereof;
 FIG. 14 is a bottom plan view thereof;
 FIG. 15 is a perspective view thereof;
 FIG. 16 is another perspective view thereof;
 FIG. 17 is a left side elevational view of a third embodiment thereof;
 FIG. 18 is a right side elevational view thereof;
 FIG. 19 is a front elevational view thereof;
 FIG. 20 is a rear elevational view thereof;
 FIG. 21 is a top plan view thereof;
 FIG. 22 is a bottom plan view thereof;
 FIG. 23 is a perspective view thereof;
 FIG. 24 is another perspective view thereof;
 FIG. 25 is a left side elevational view of a fourth embodiment thereof;
 FIG. 26 is a right side elevational view thereof;
 FIG. 27 is a front elevational view thereof;
 FIG. 28 is a rear elevational view thereof;
 FIG. 29 is a top plan view thereof;
 FIG. 30 is a bottom plan view thereof;
 FIG. 31 is a perspective view thereof; and,
 FIG. 32 is another perspective view thereof.

1 Claim, 16 Drawing Sheets

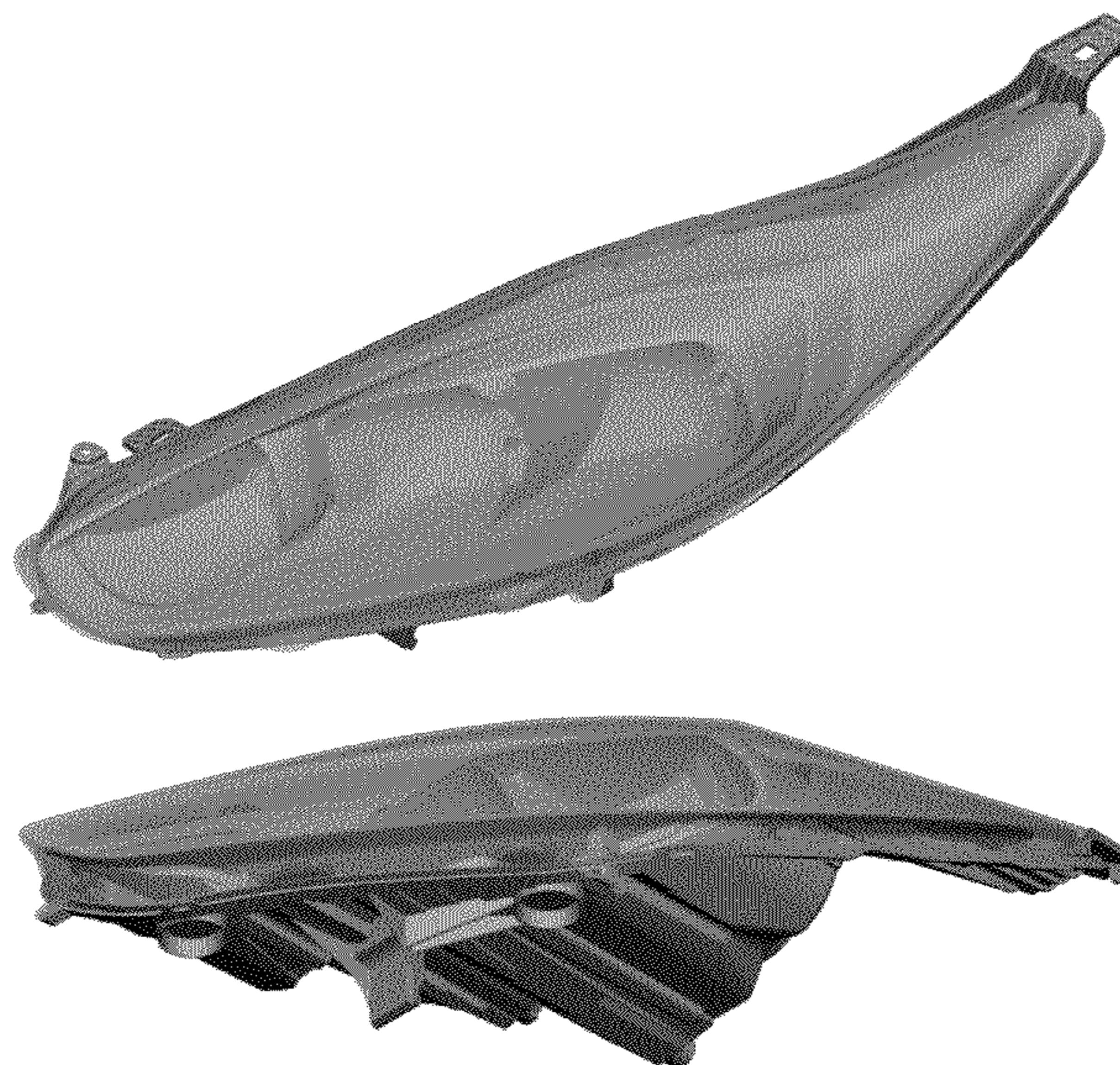

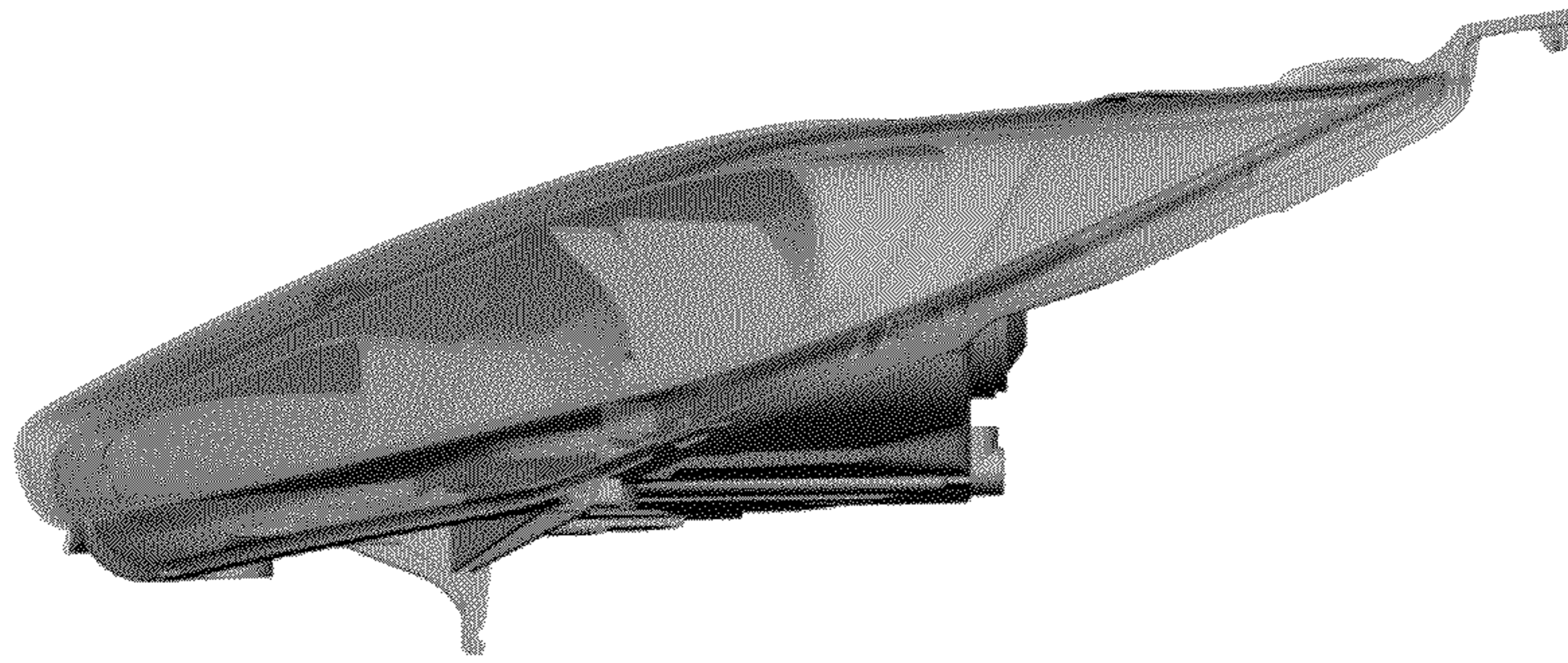

Figure 1

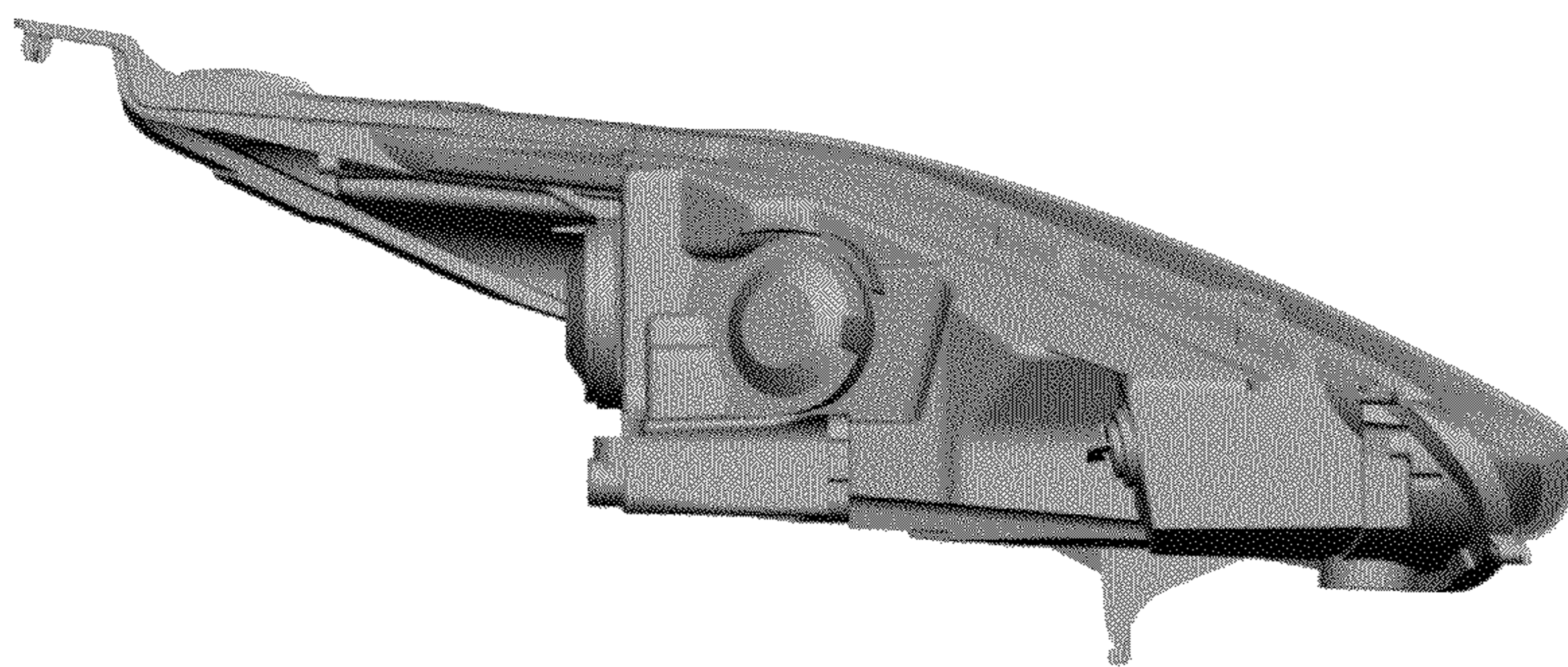

Figure 2

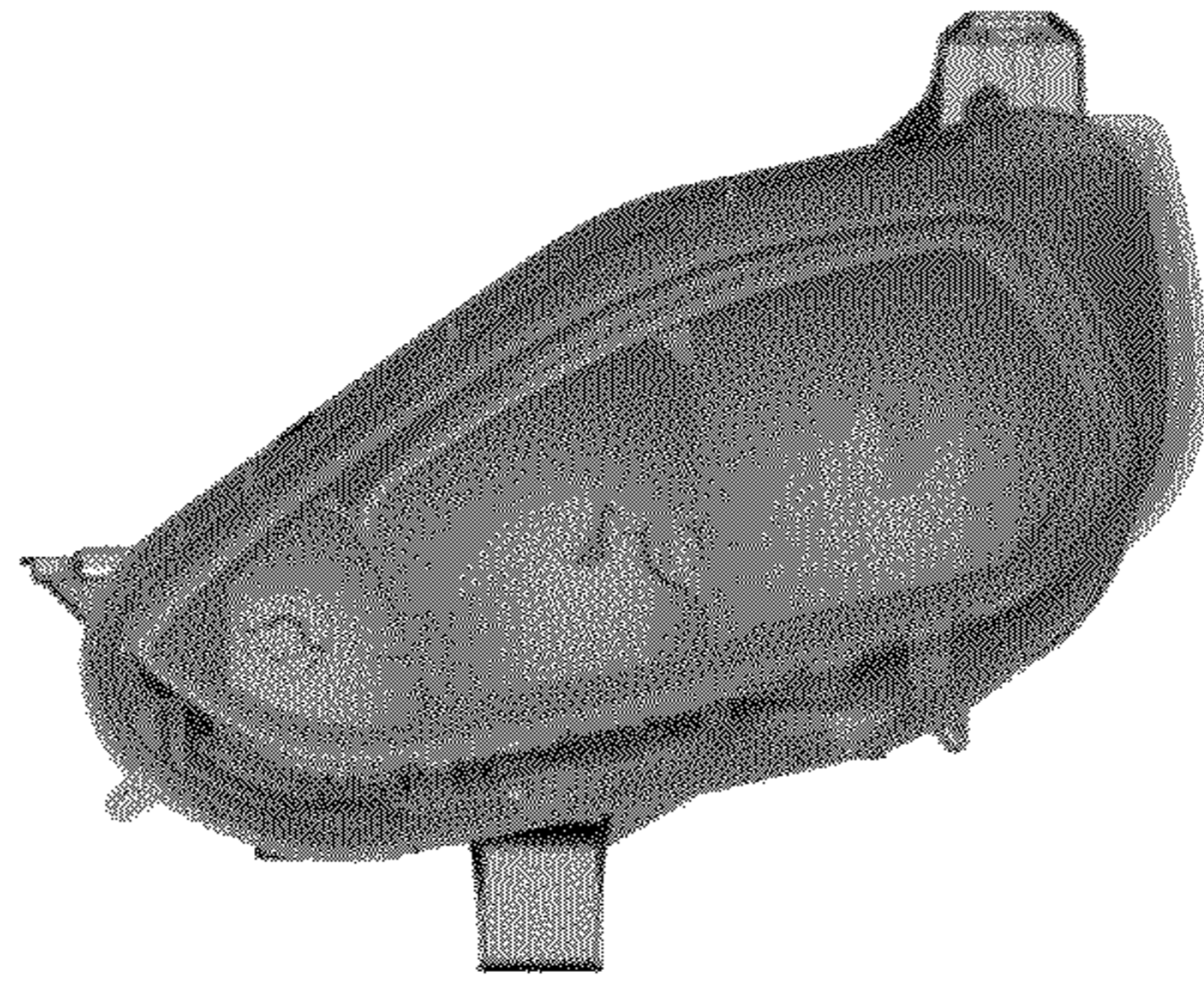

Figure 3

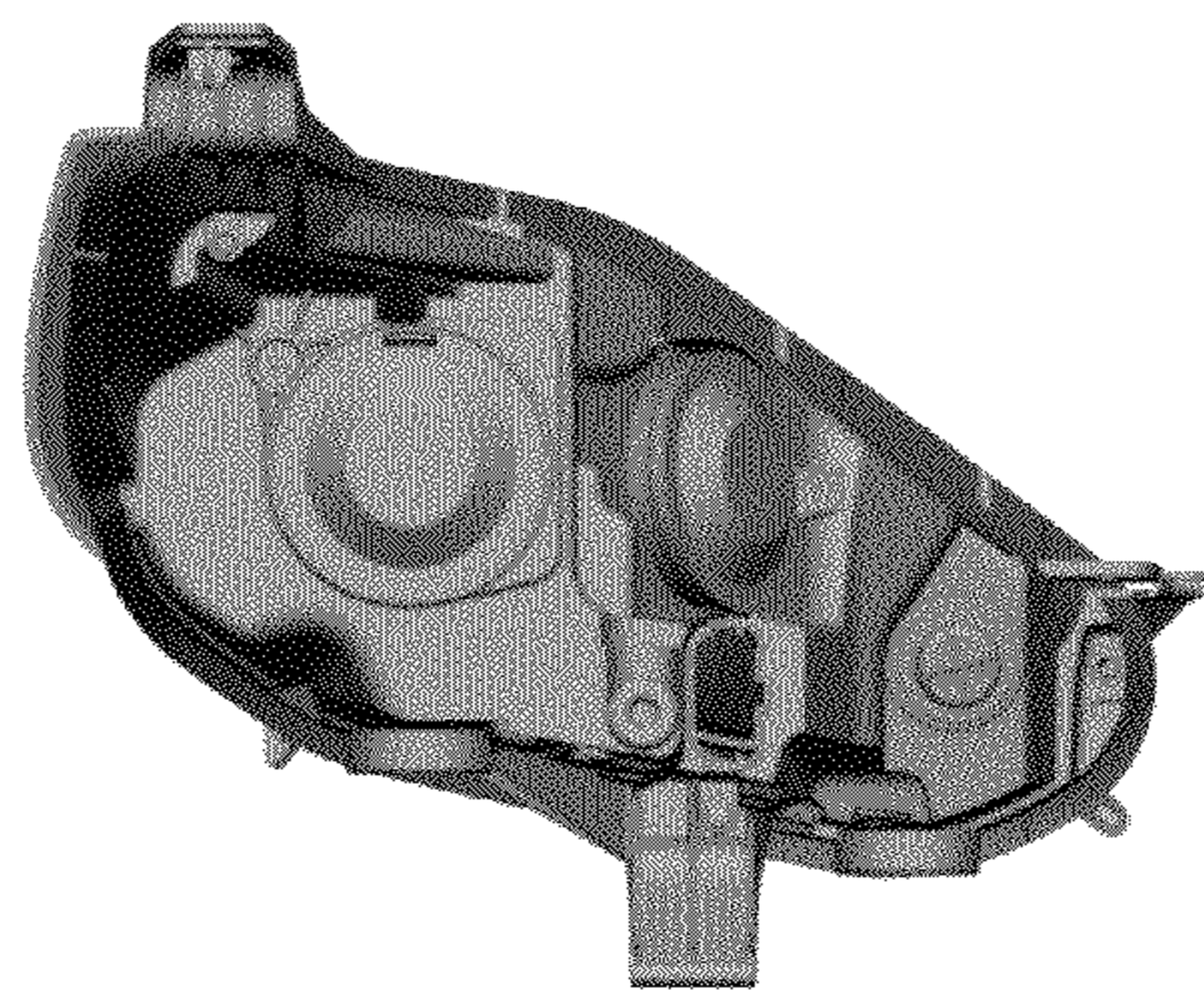

Figure 4

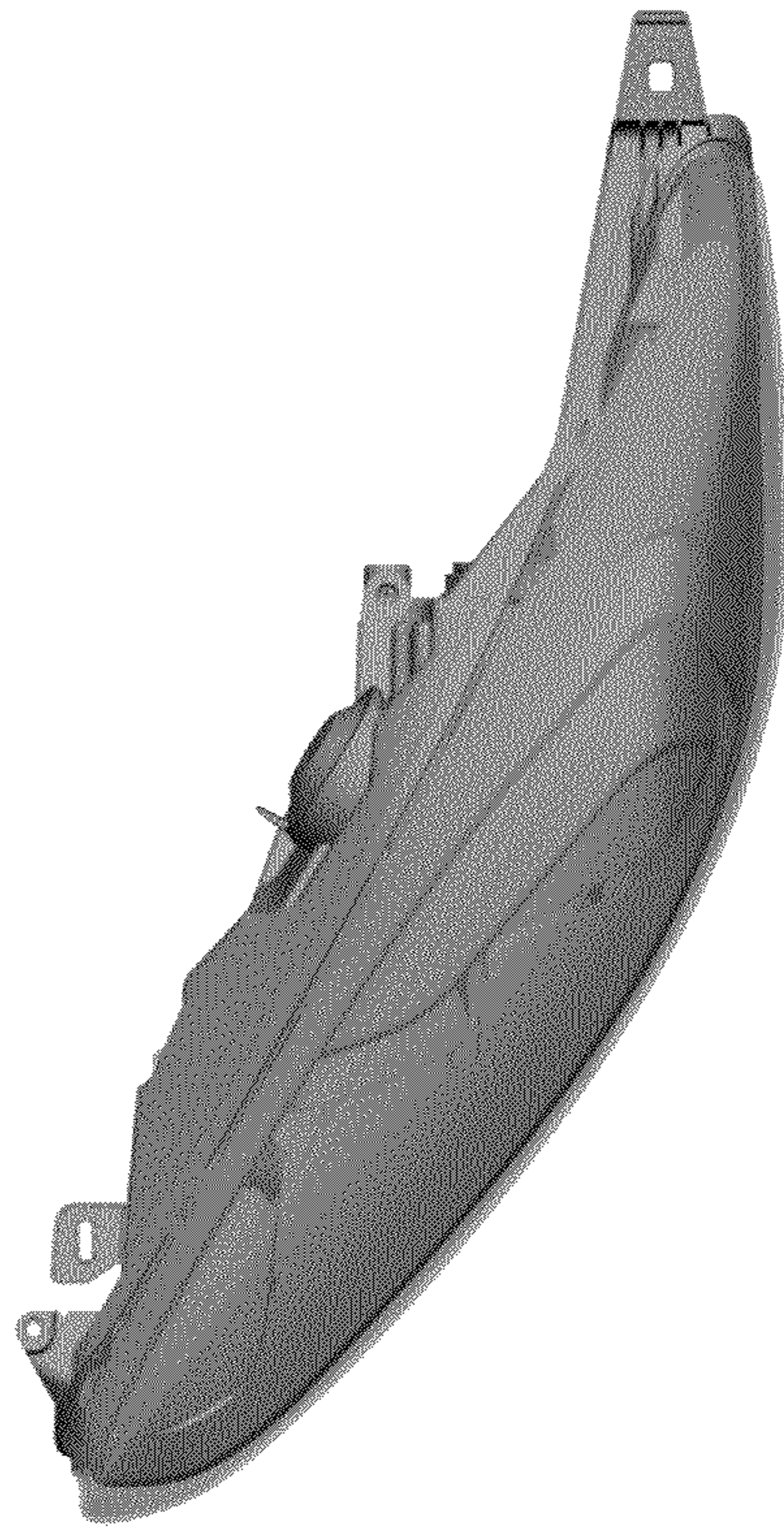

Figure 5

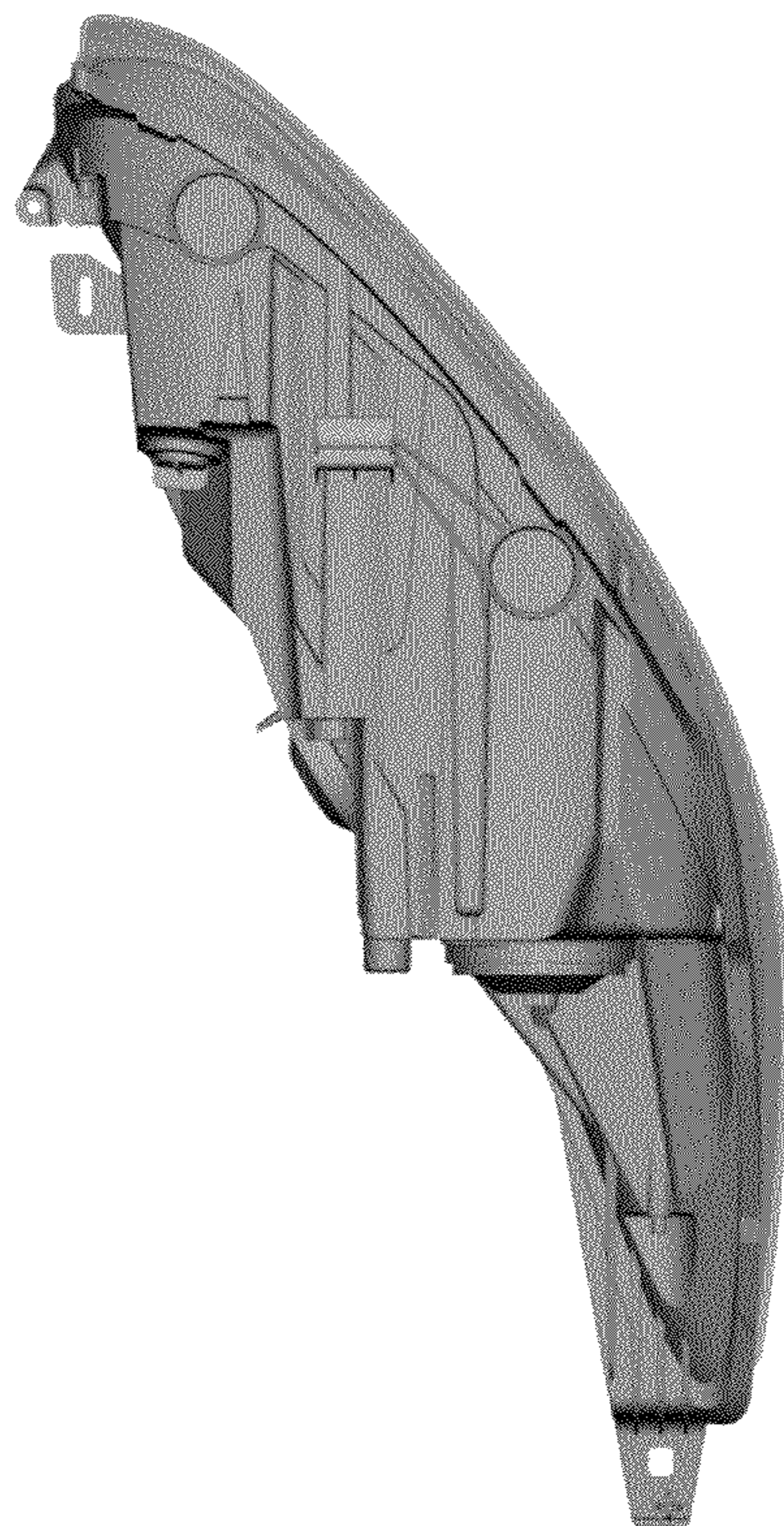

Figure 6

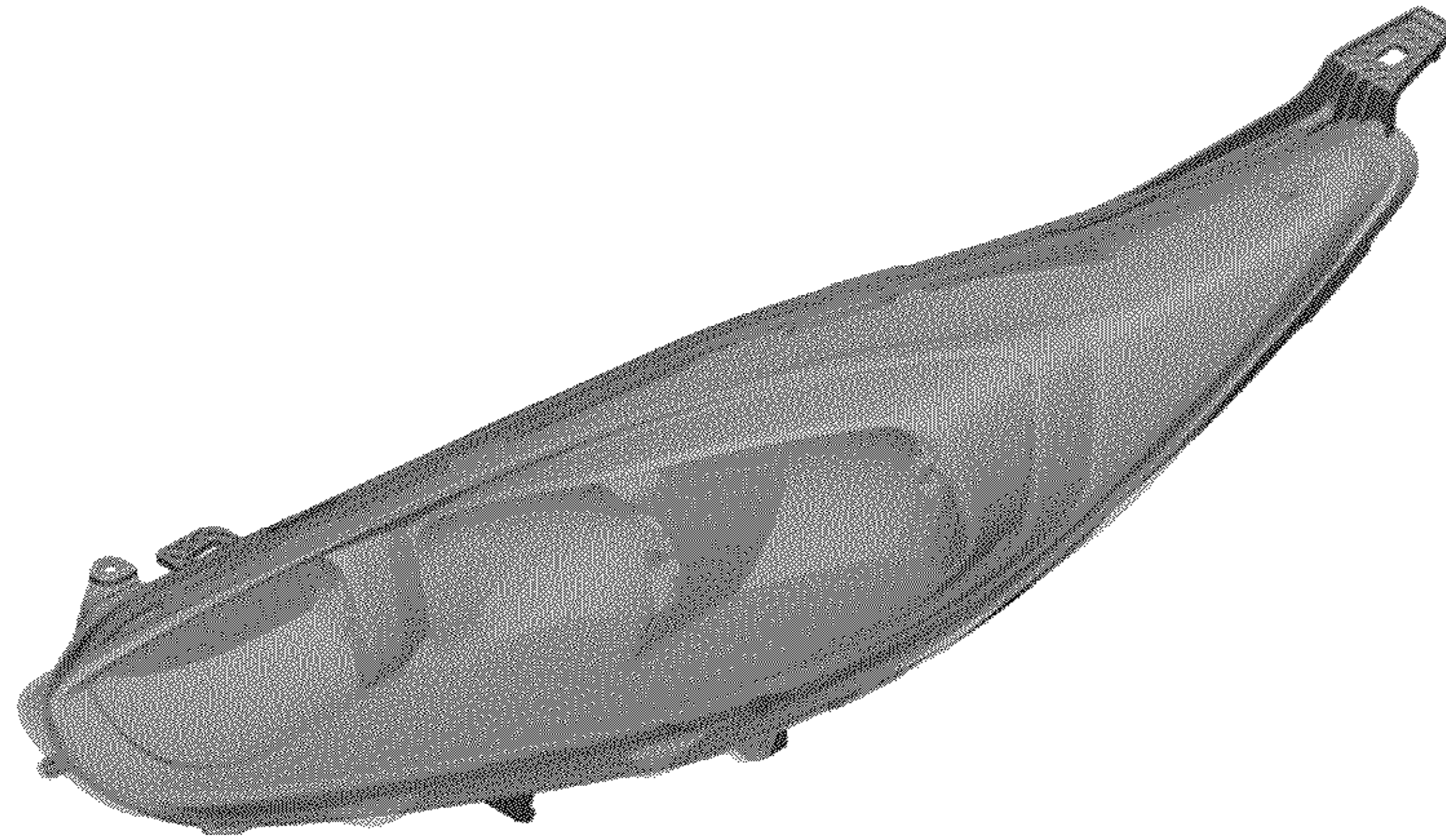

Figure 7

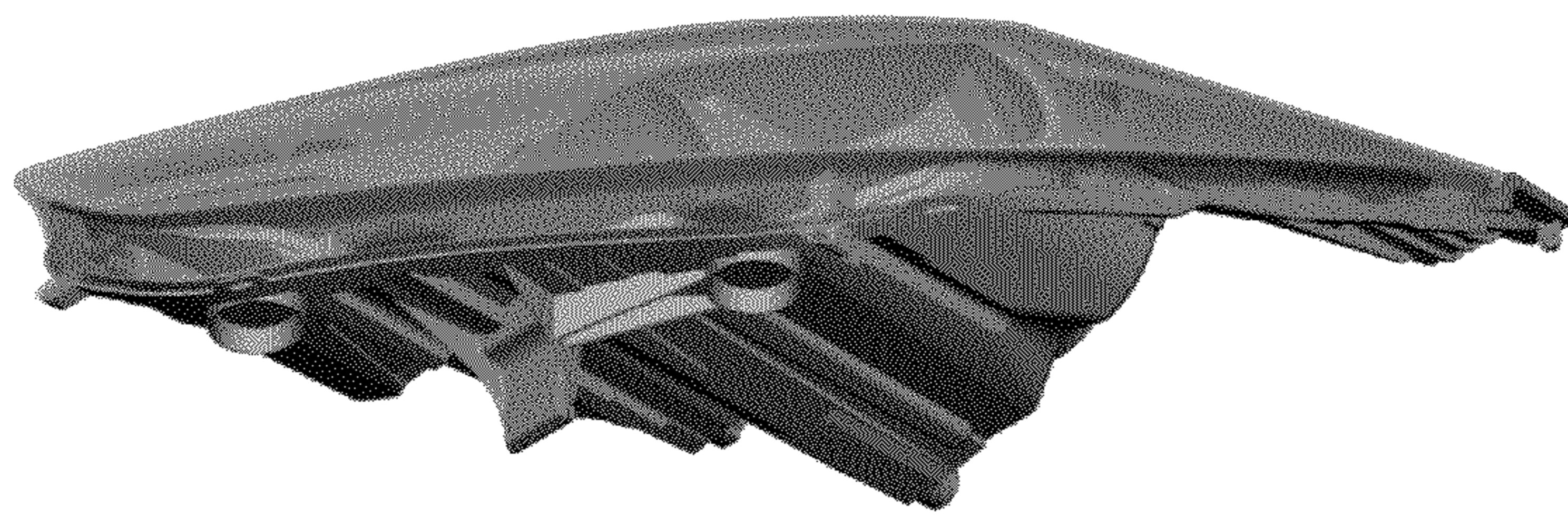

Figure 8

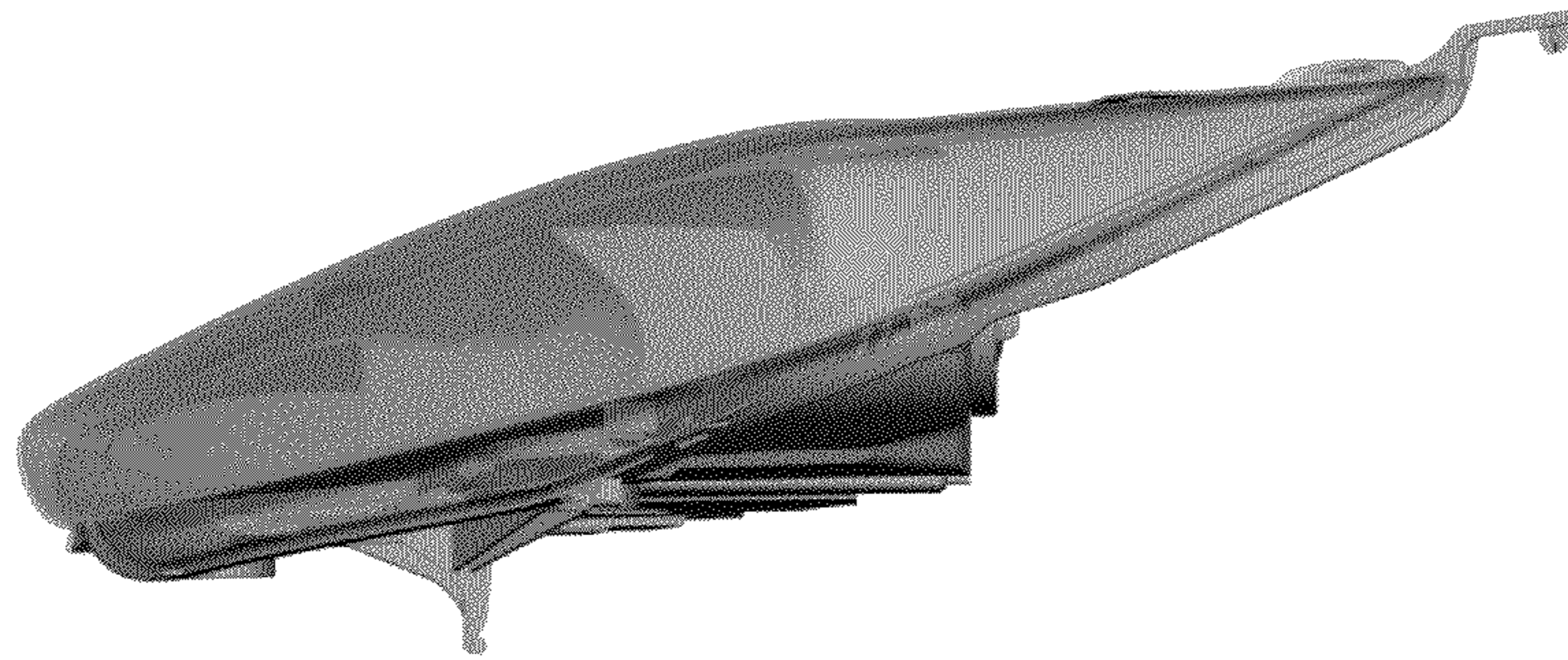

Figure 9

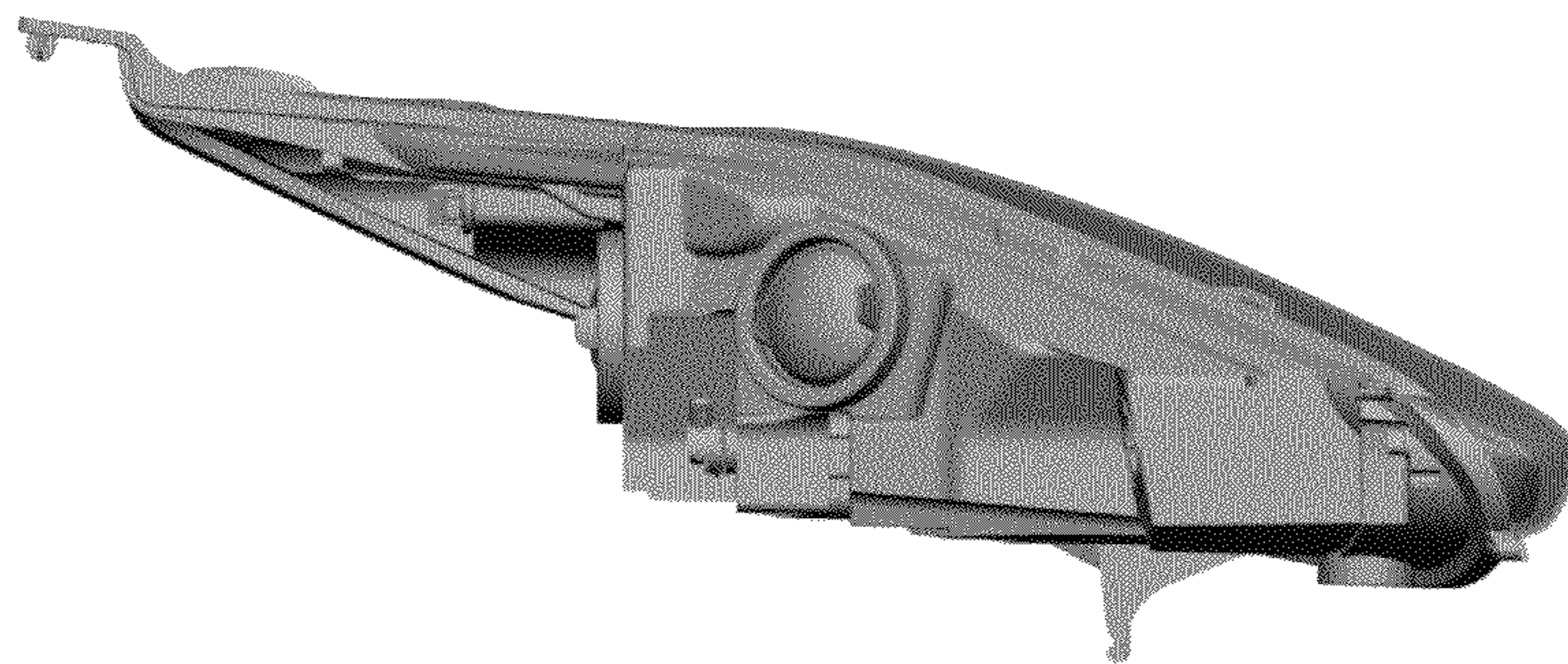

Figure 10

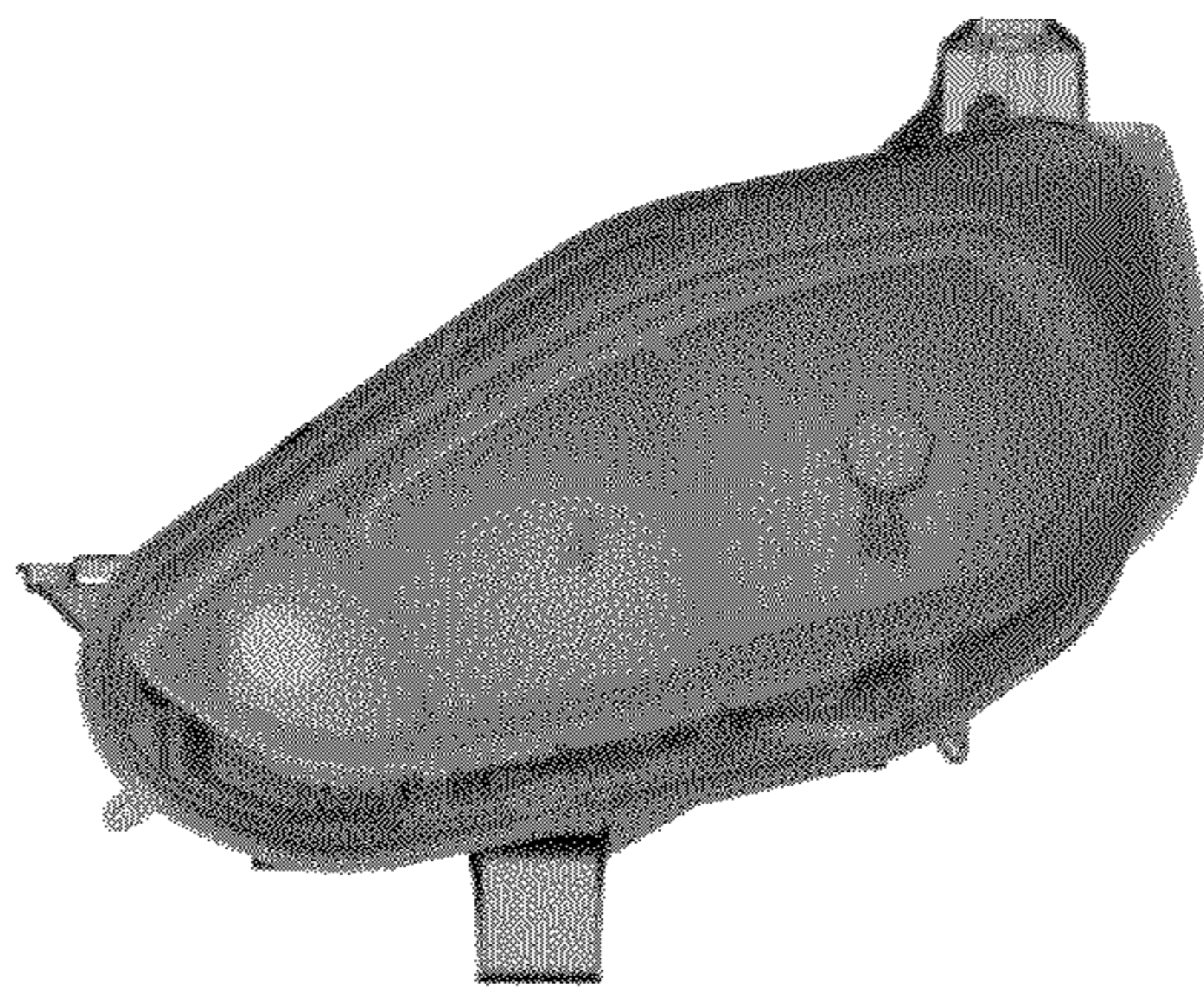

Figure 11

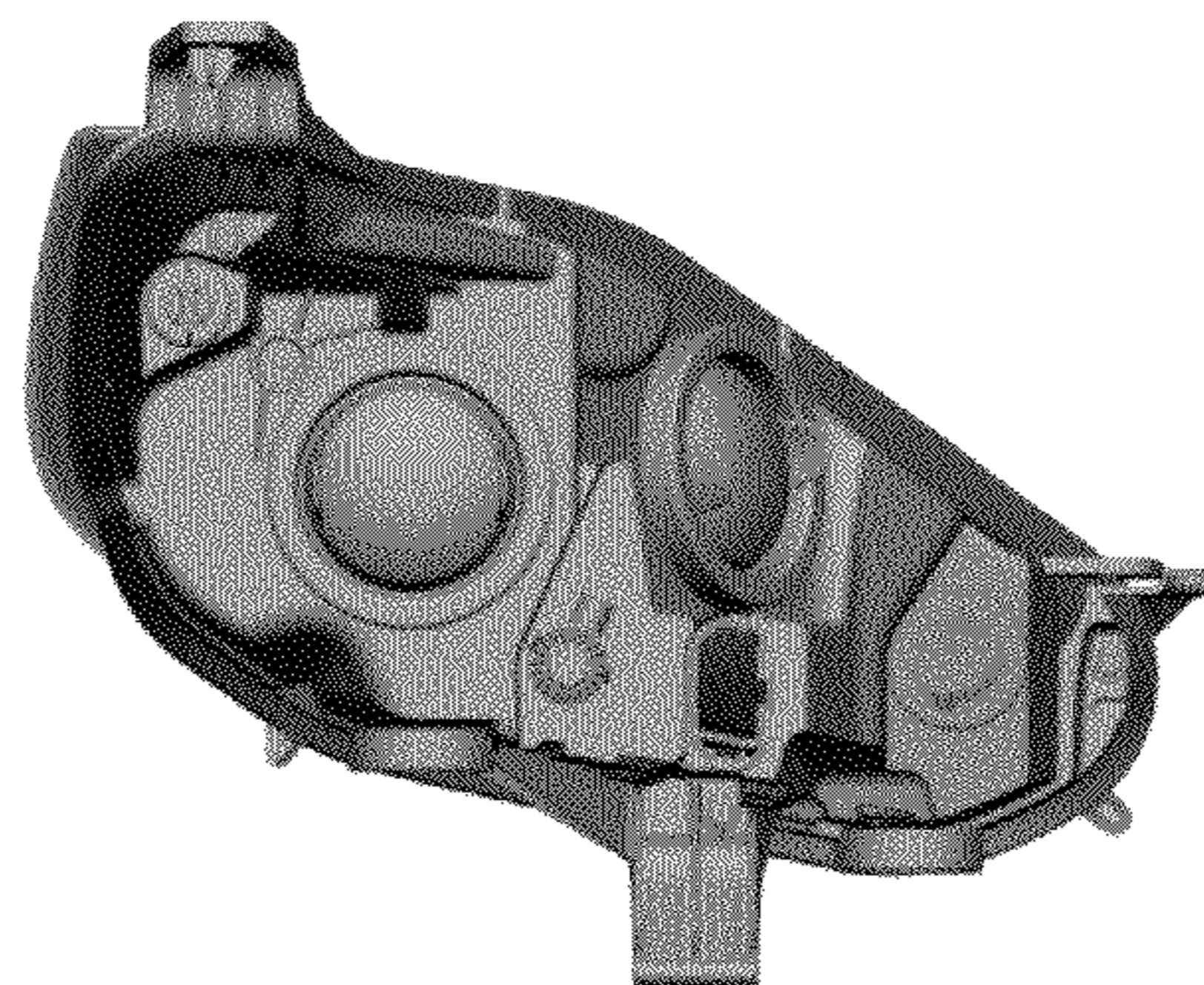

Figure 12

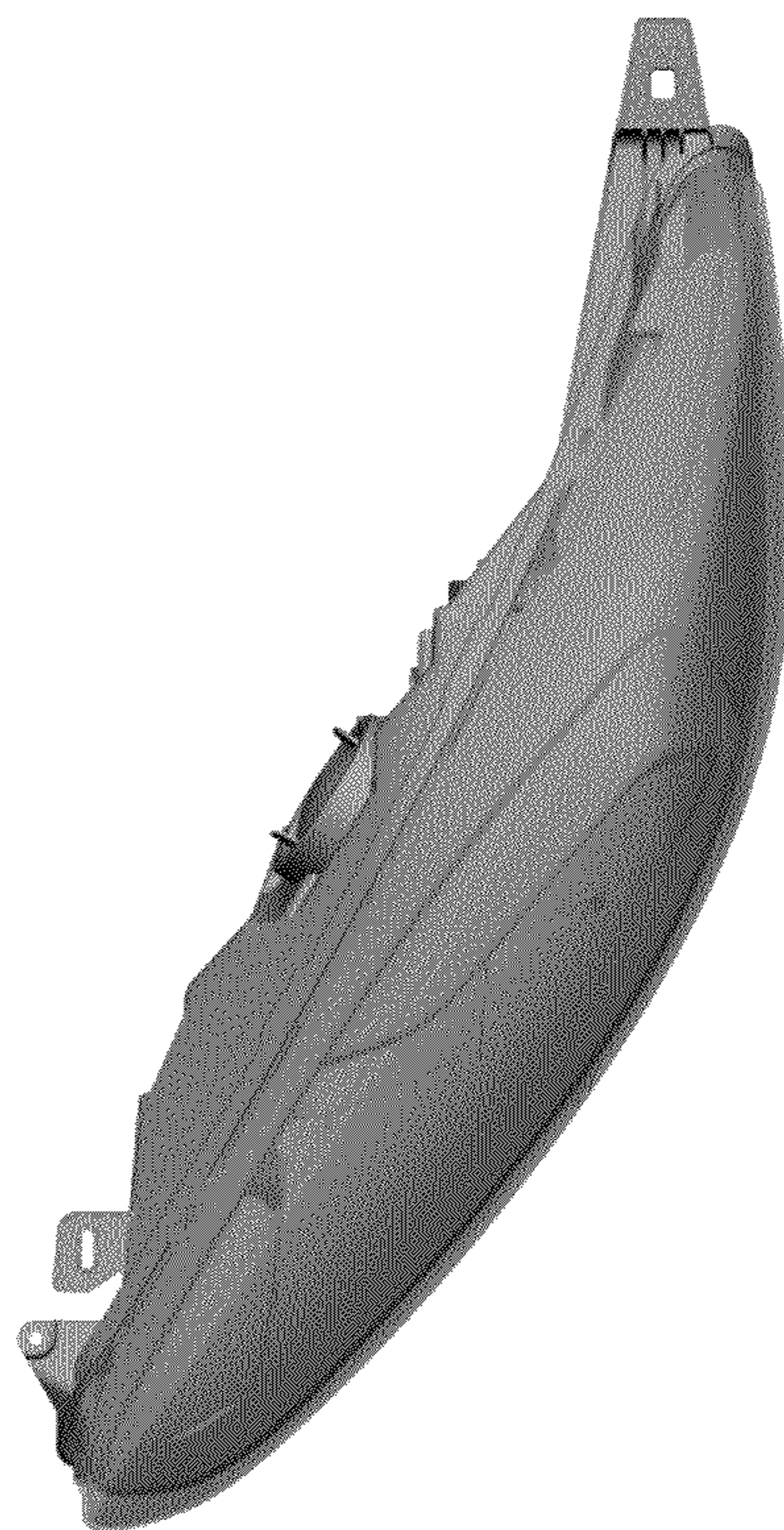

Figure 13

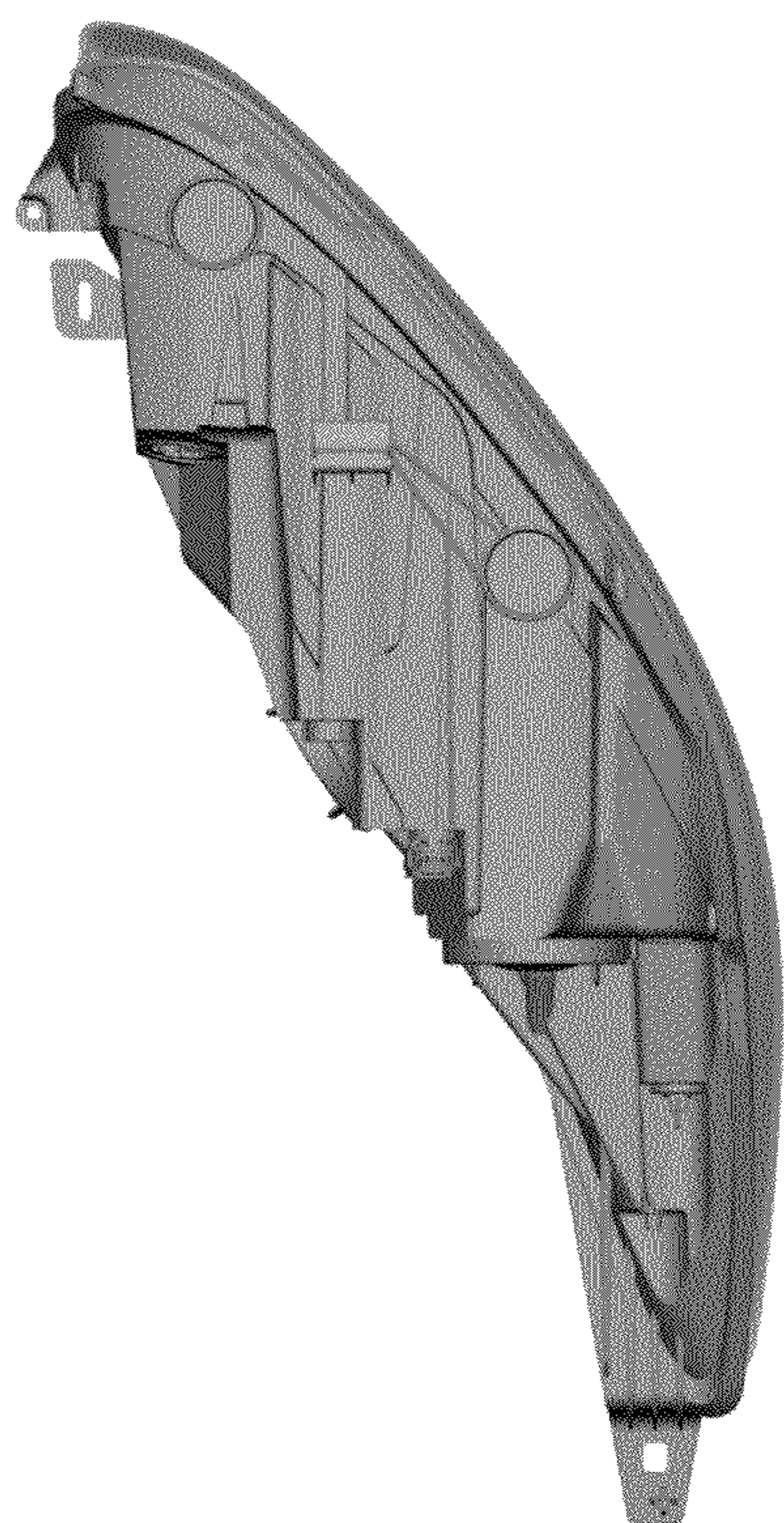

Figure 14

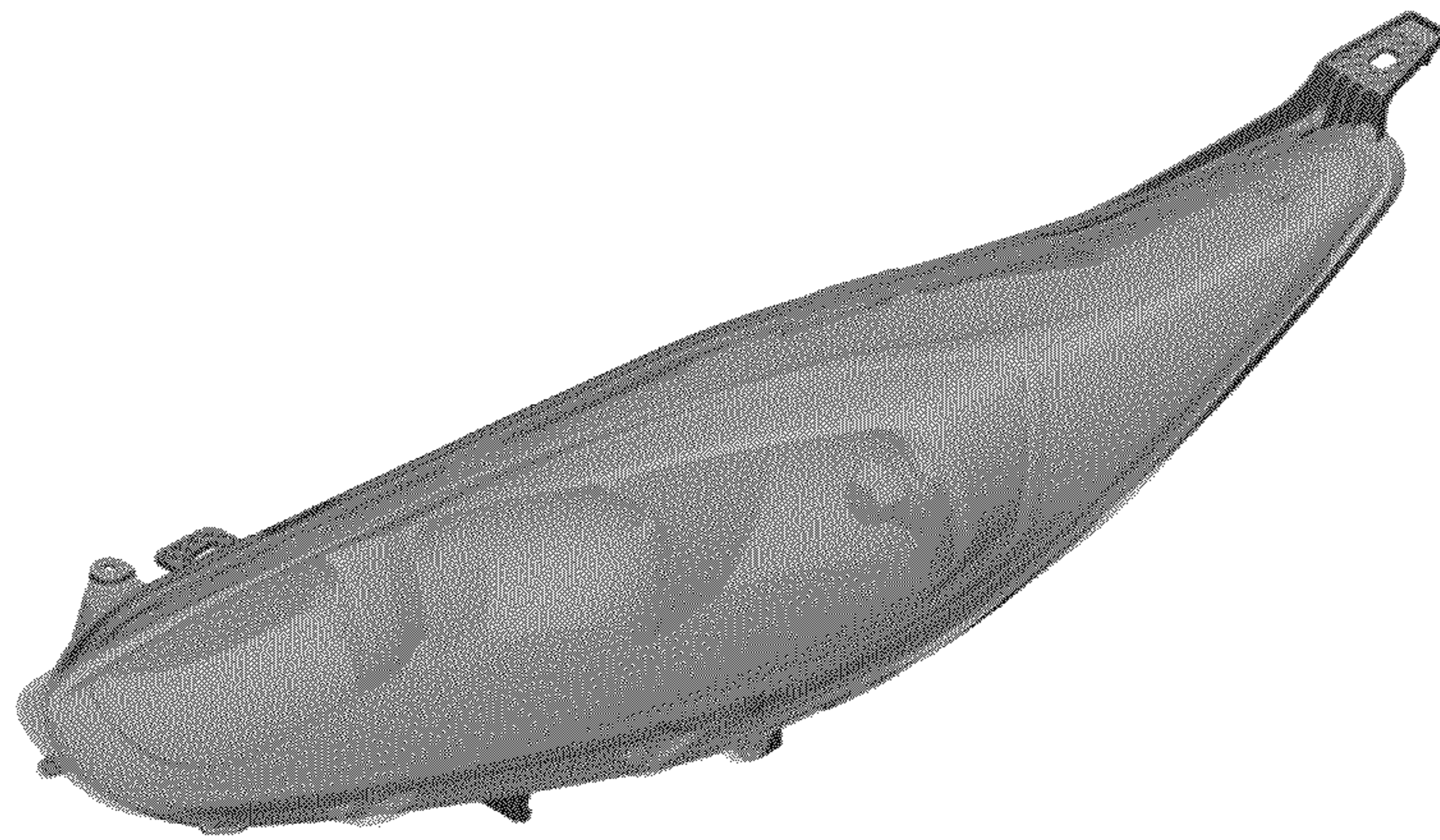

Figure 15

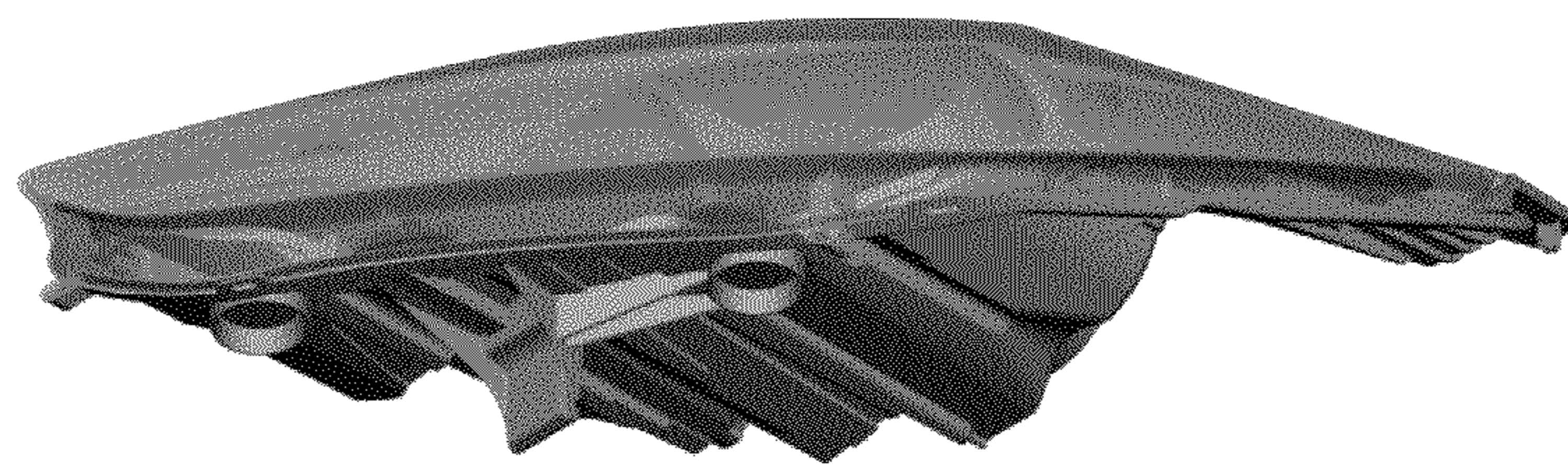

Figure 16

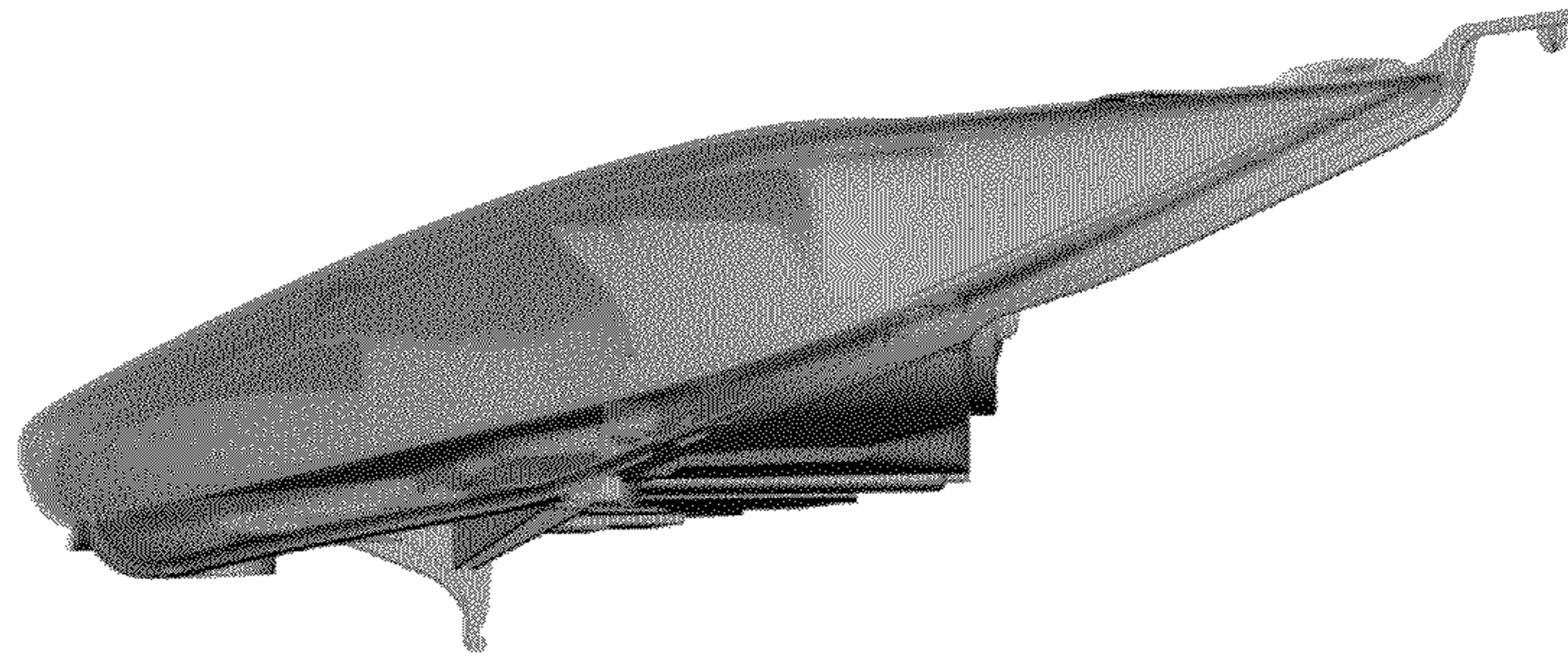

Figure 17

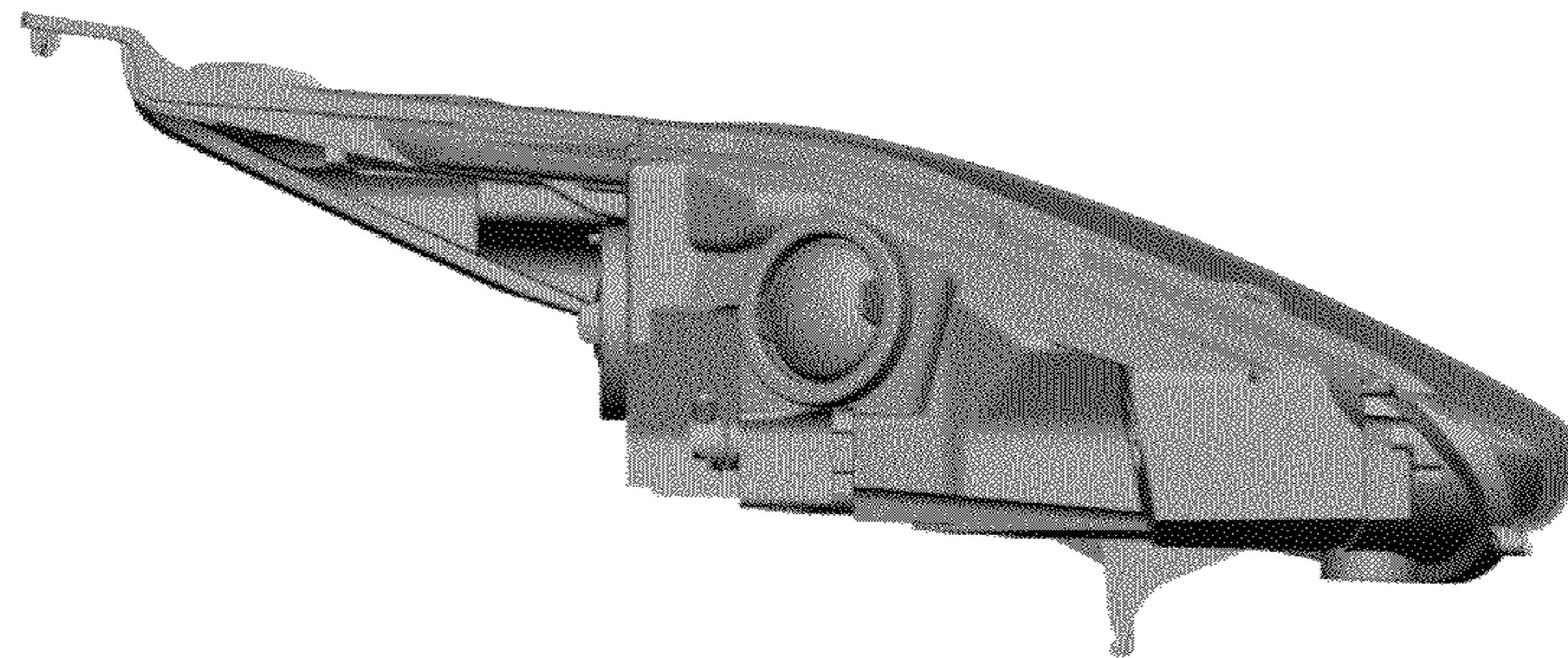

Figure 18

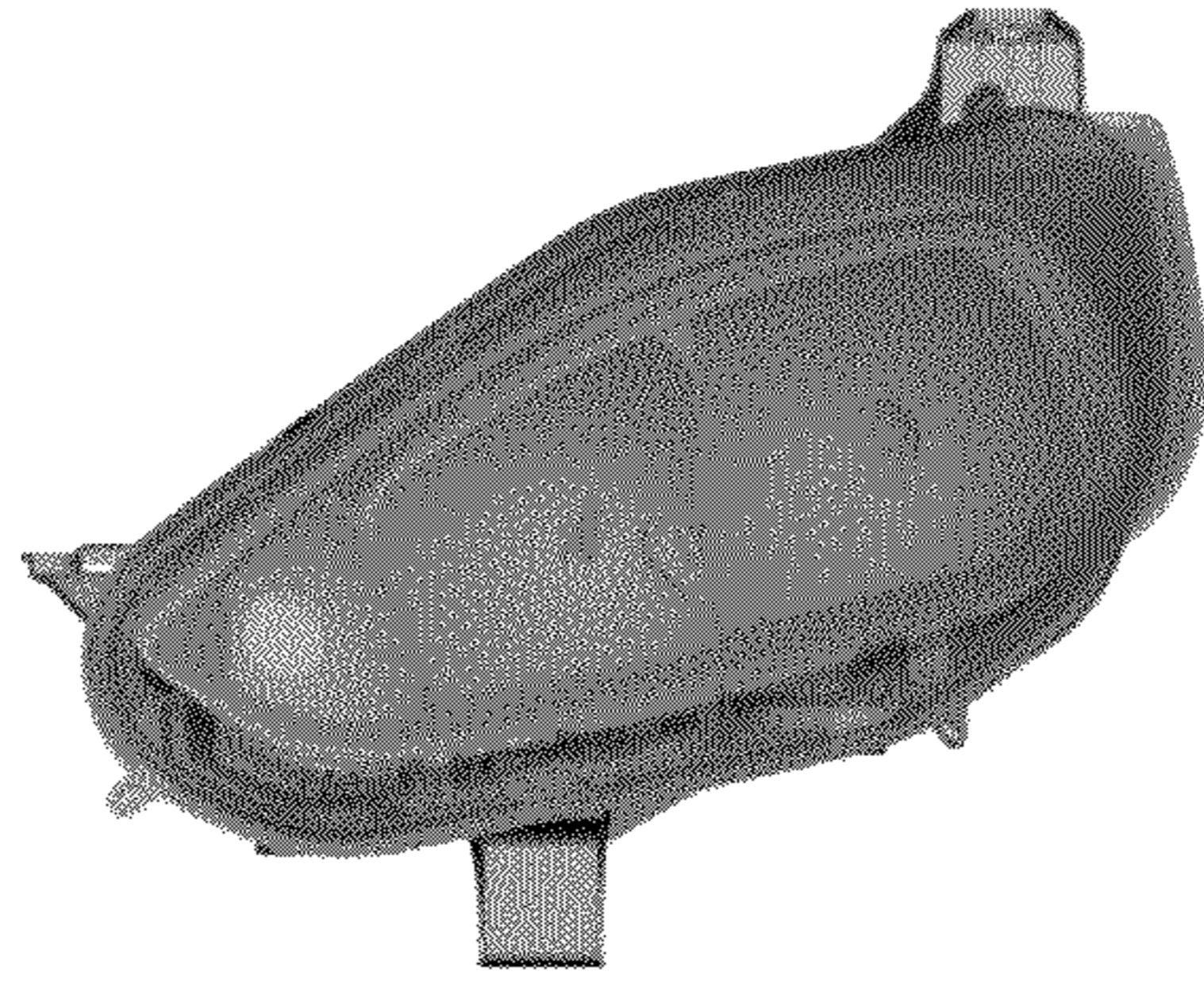

Figure 19

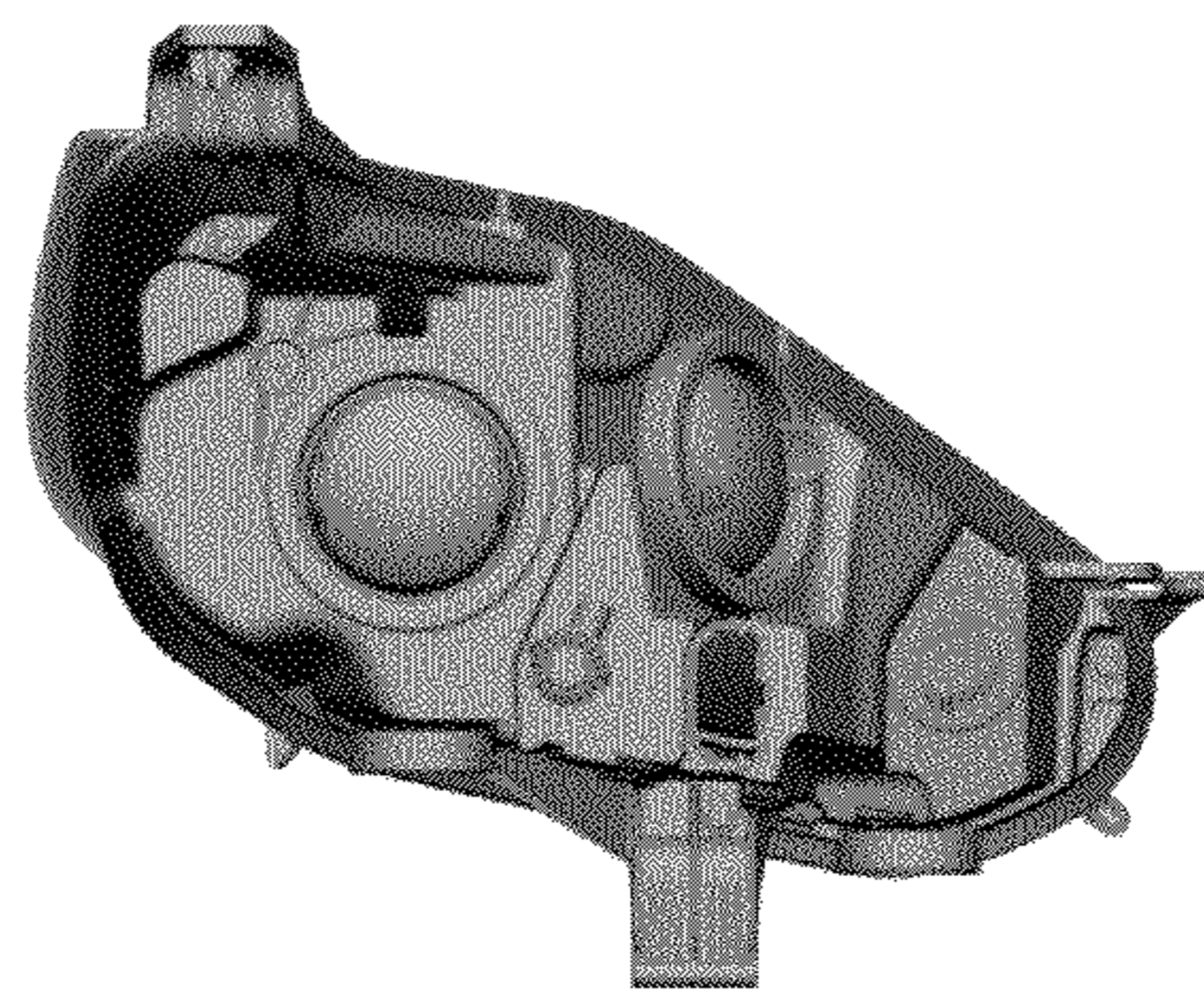

Figure 20

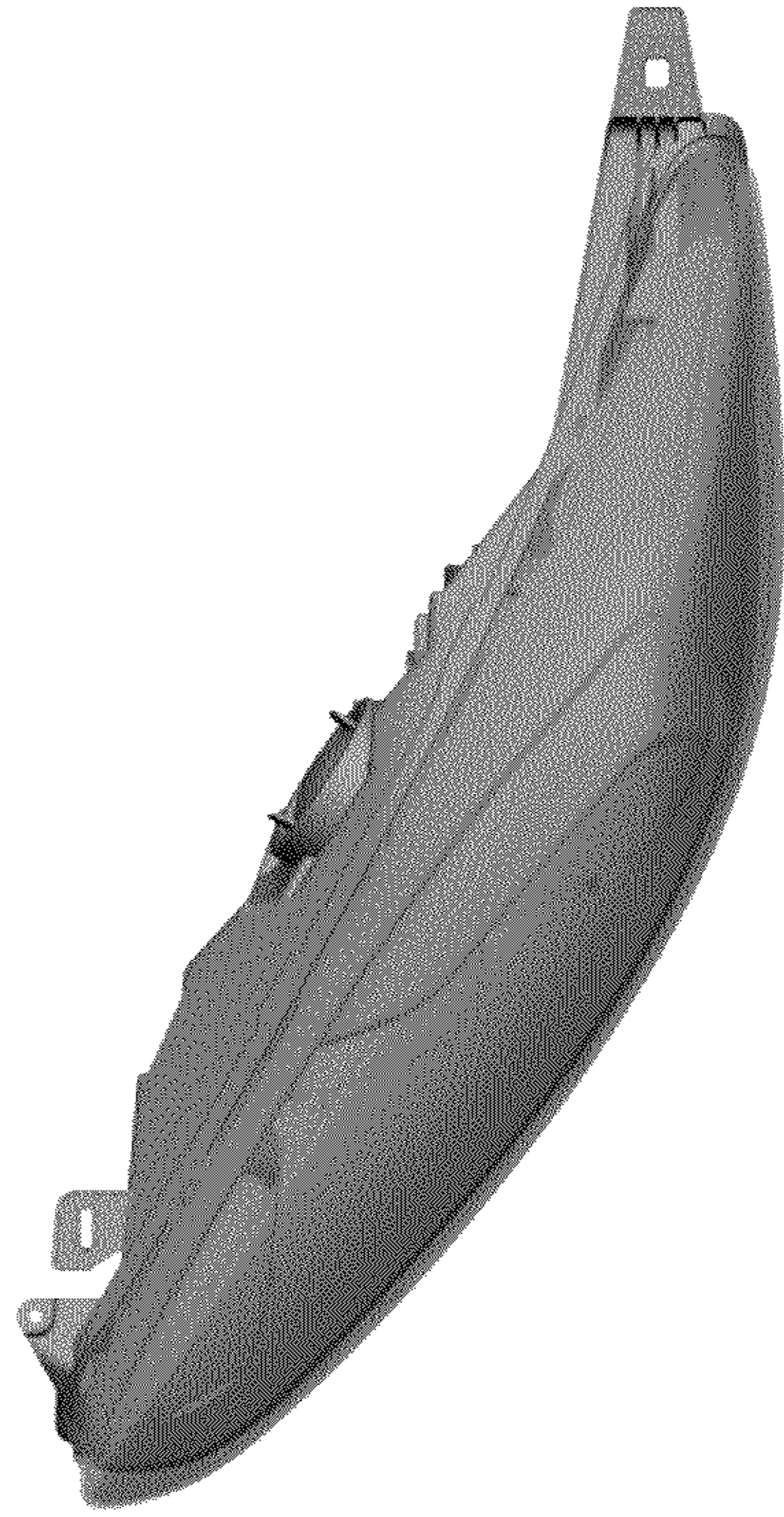

Figure 21

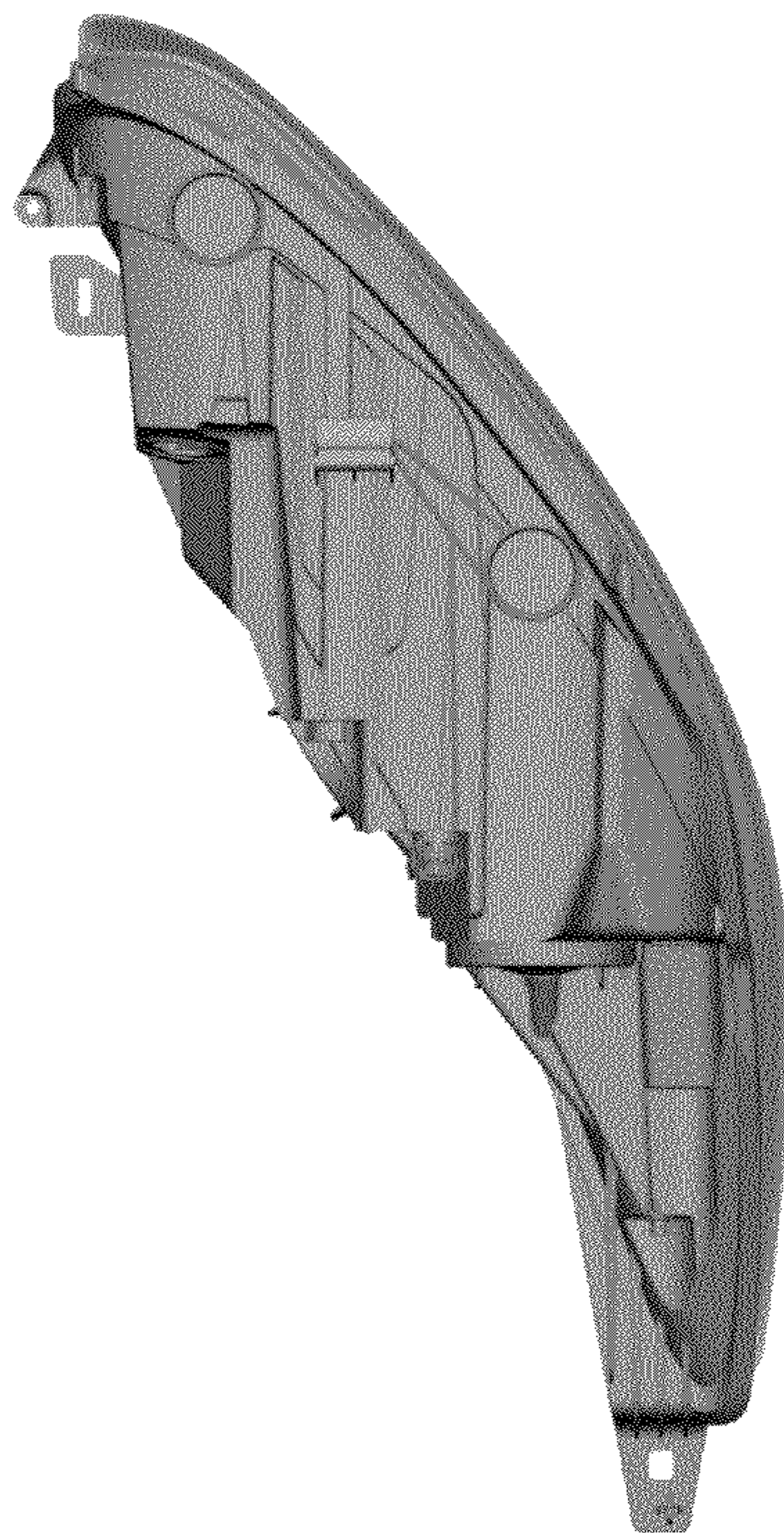

Figure 22

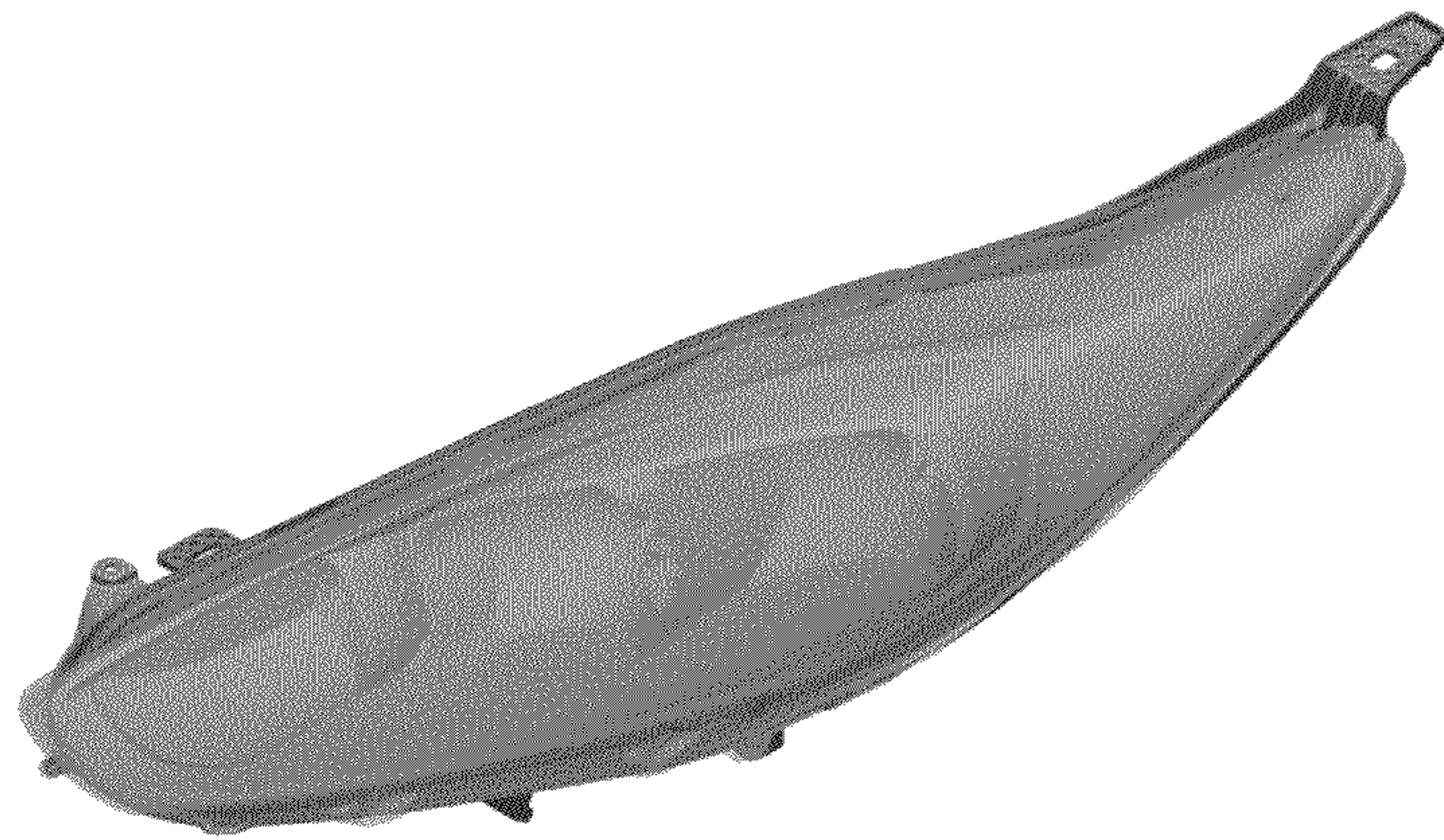

Figure 23

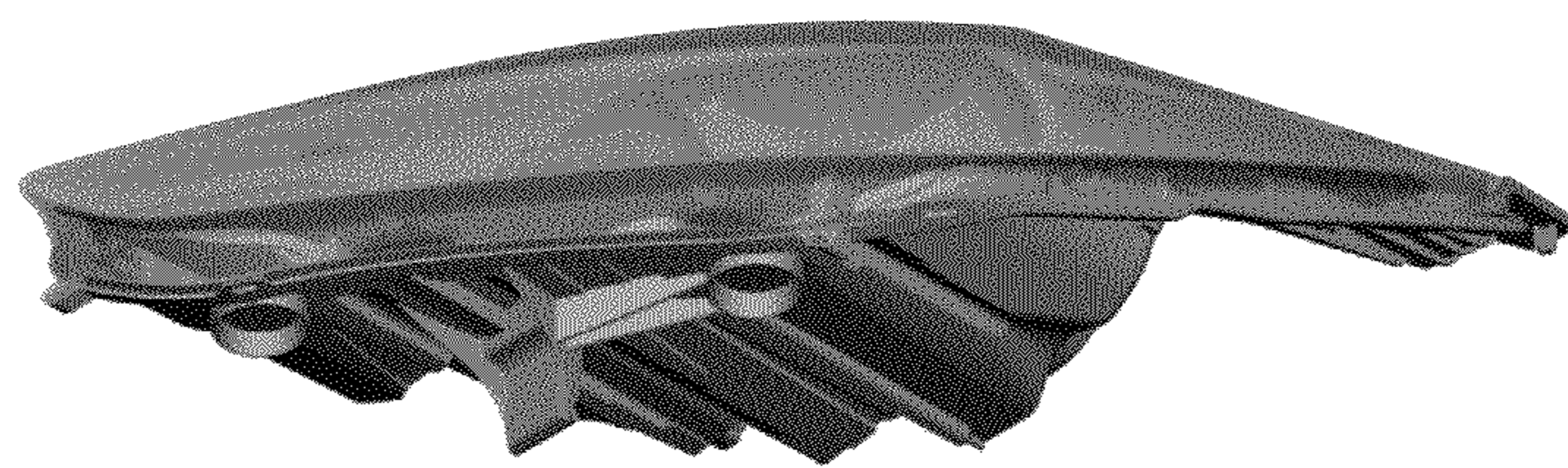

Figure 24

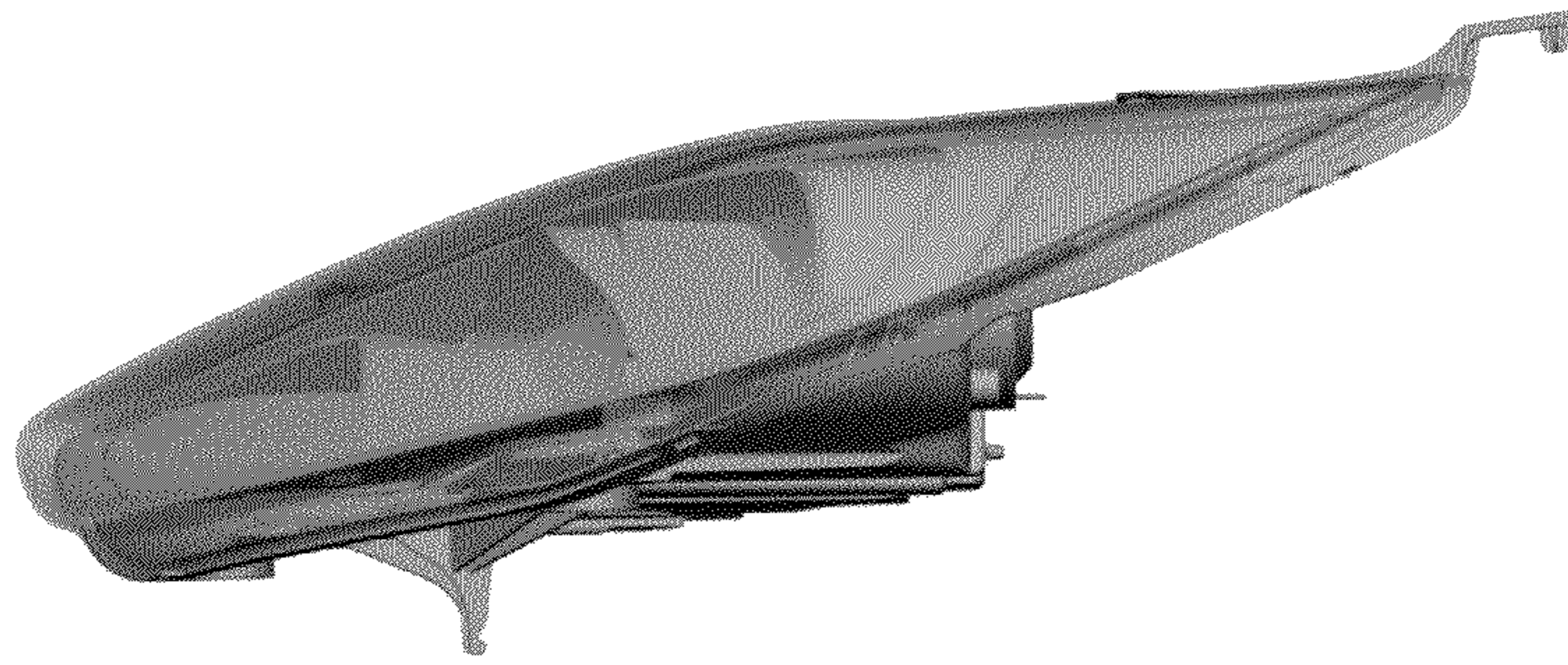

Figure 25

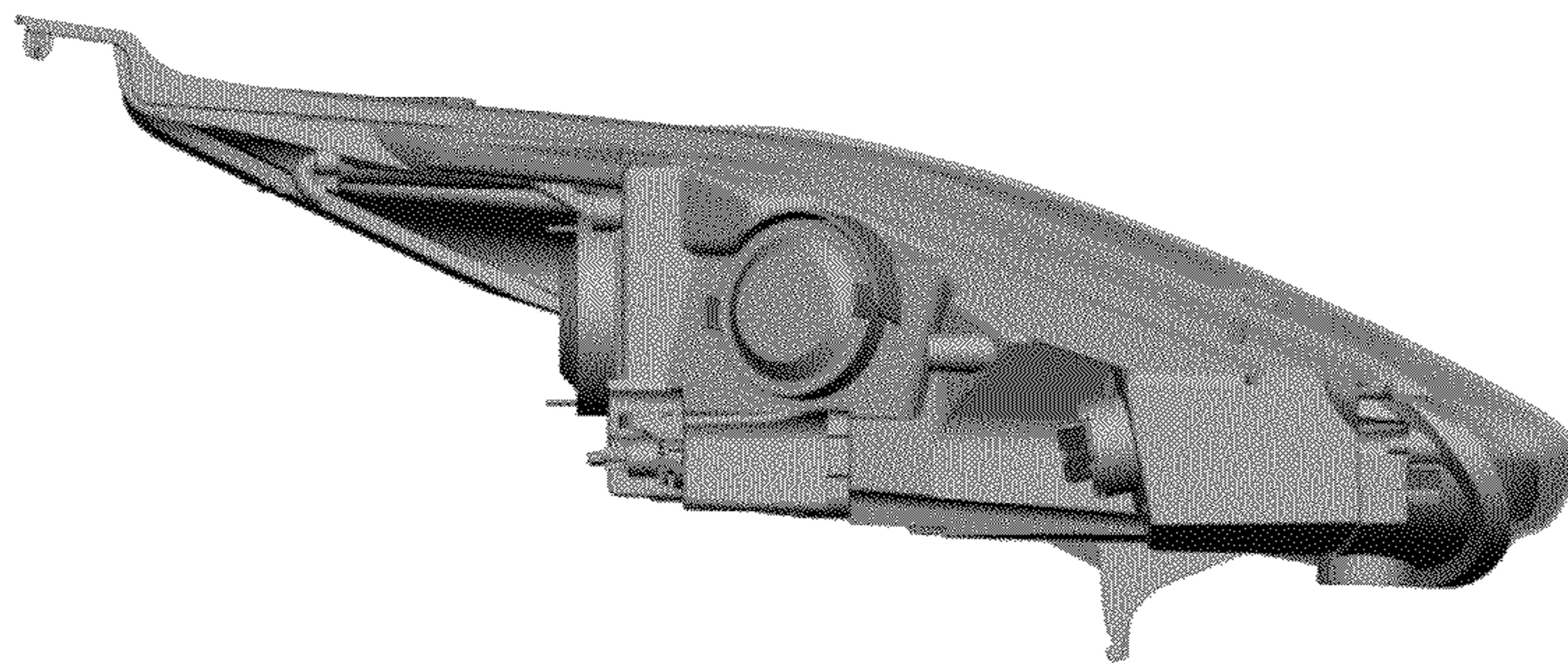

Figure 26

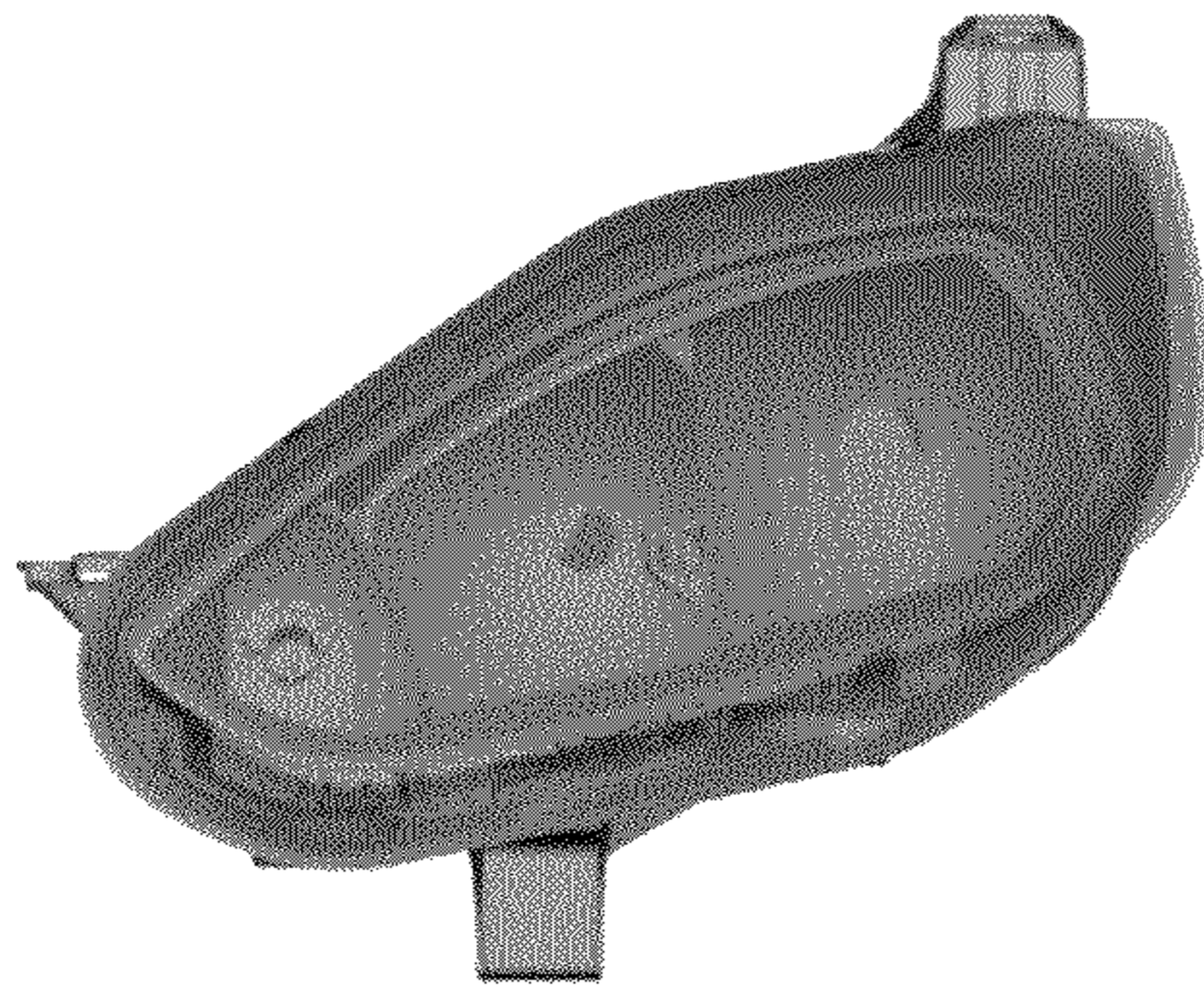

Figure 27

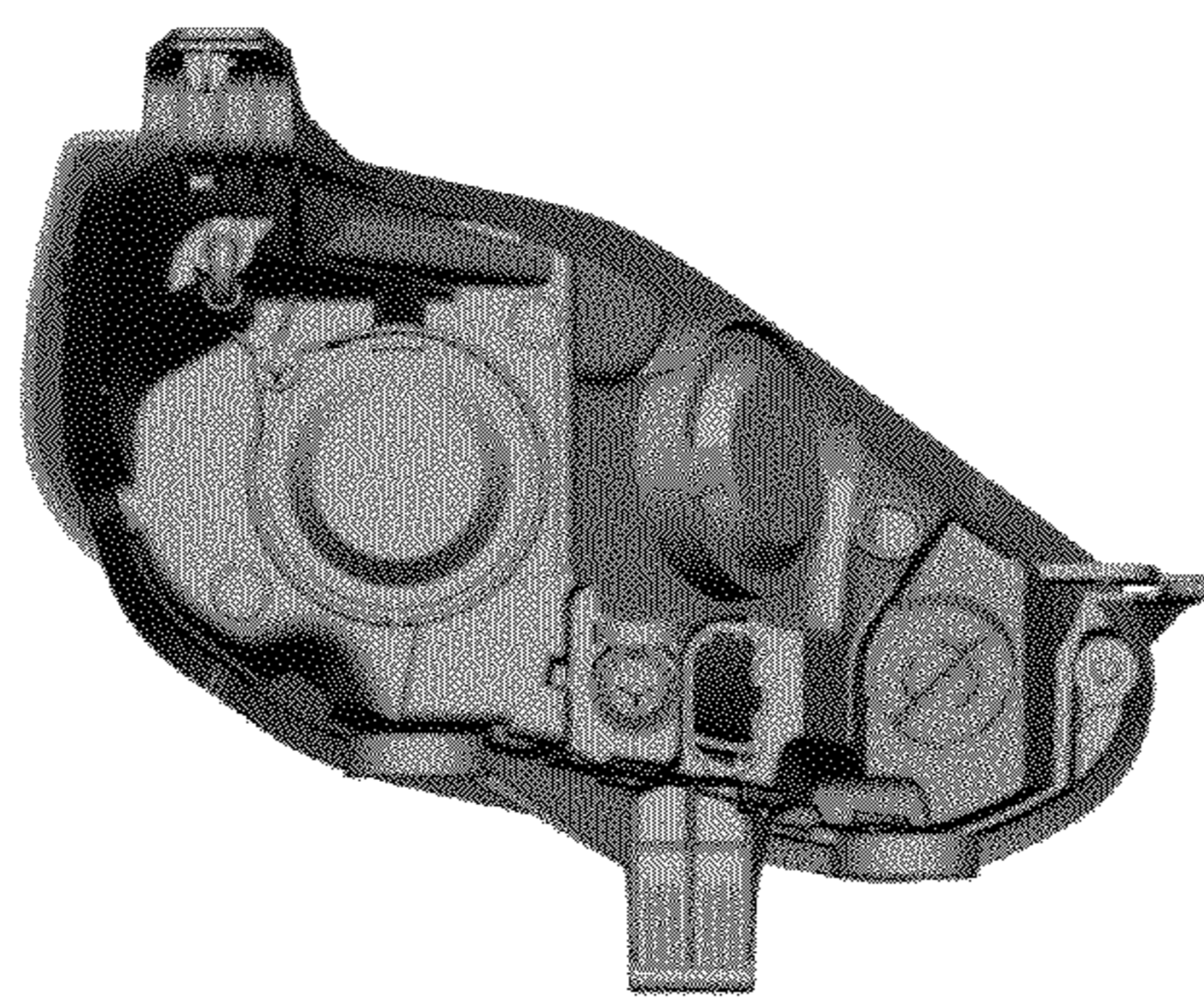

Figure 28

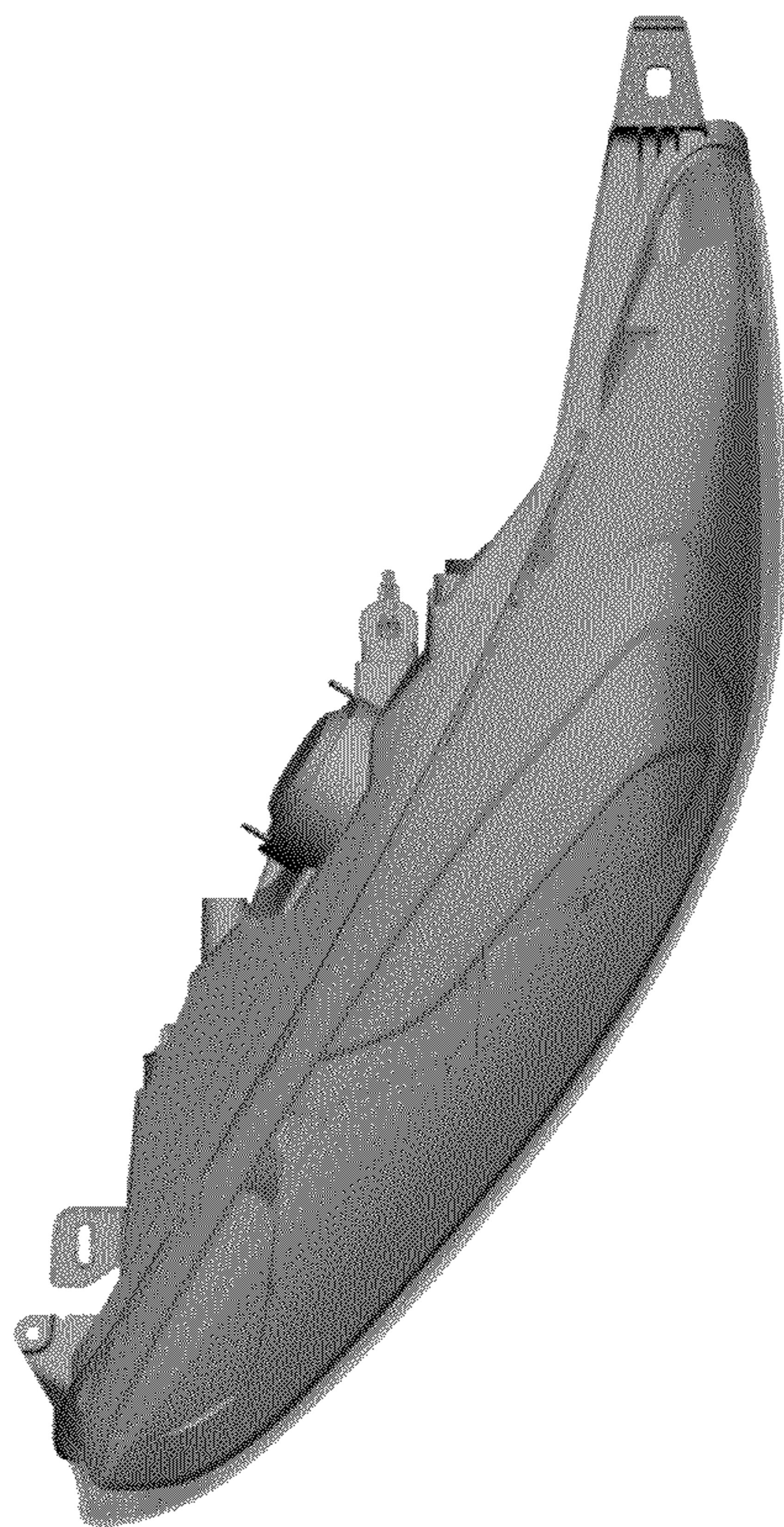

Figure 29

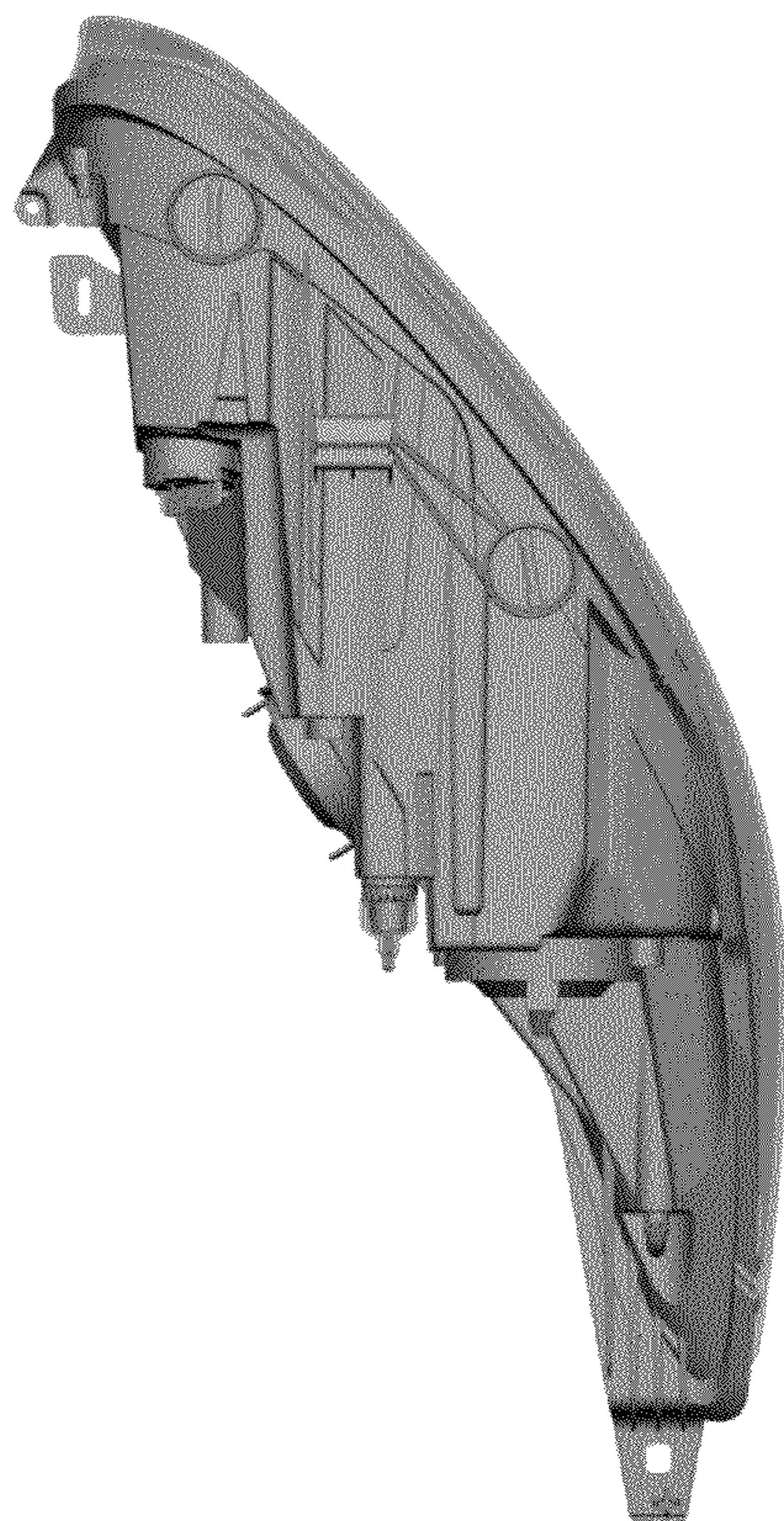

Figure 30

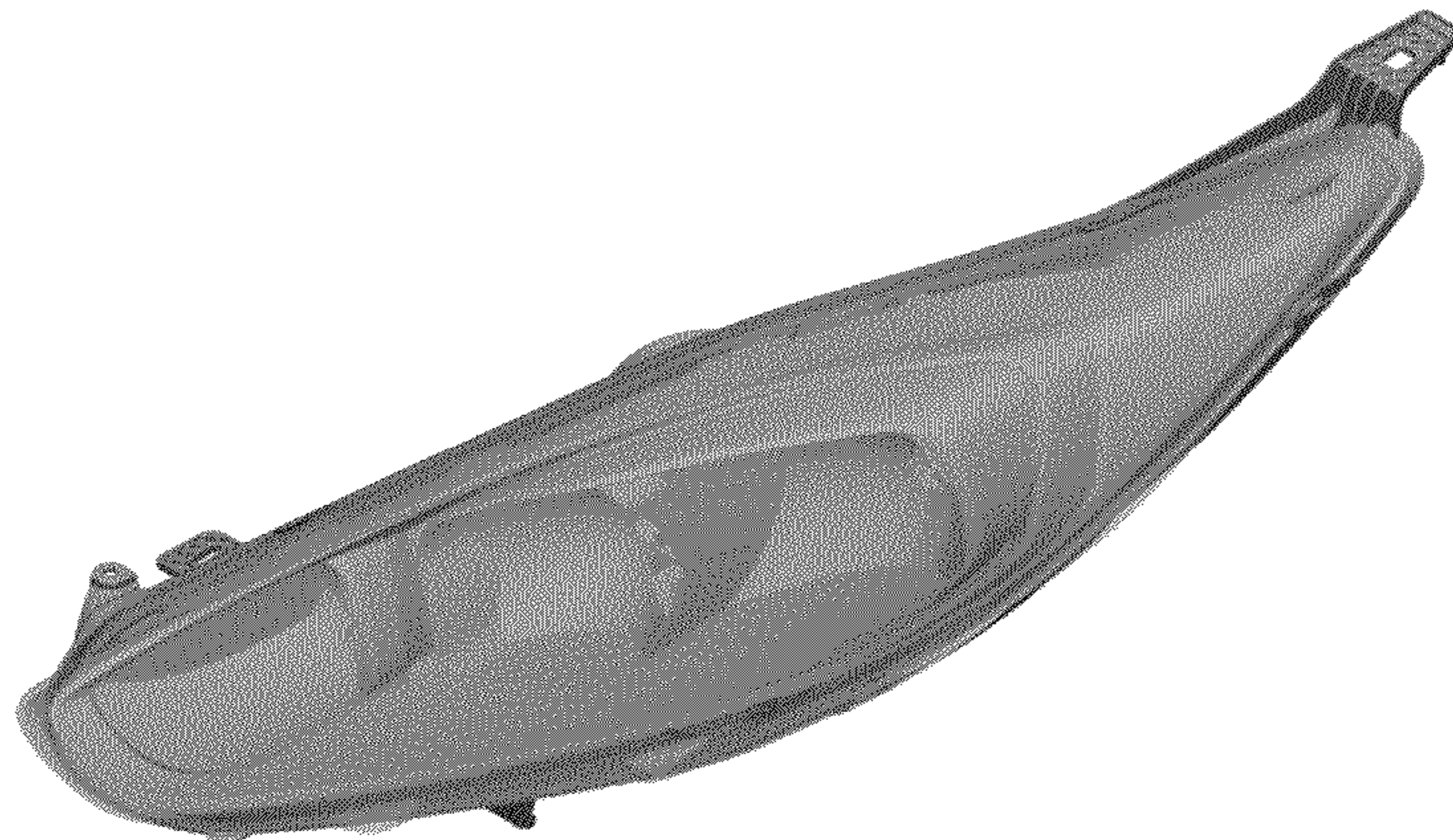

Figure 31

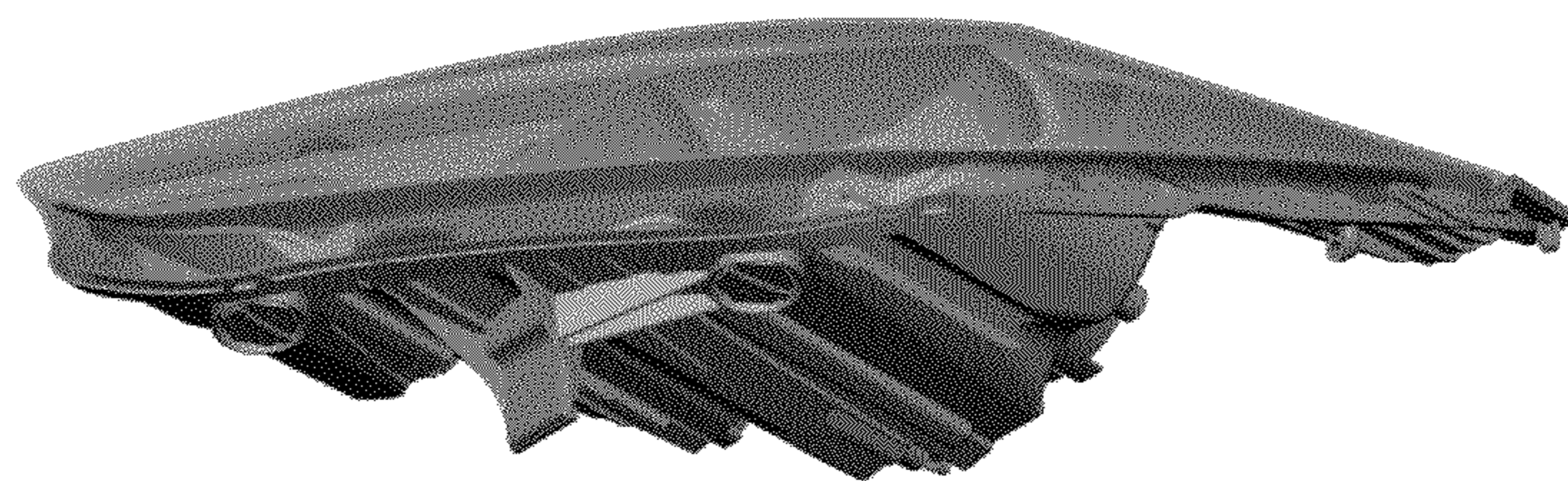

Figure 32