



US00D719553S

(12) **United States Design Patent**
Noto

(10) **Patent No.:** **US D719,553 S**
(45) **Date of Patent:** **** Dec. 16, 2014**

- (54) **PICKUP MICROPHONE**
- (71) Applicant: **Seiko Instruments Inc.**, Chiba (JP)
- (72) Inventor: **Naohiko Noto**, Chigasaki (JP)
- (73) Assignee: **Seiko Instruments Inc.** (JP)
- (**) Term: **14 Years**
- (21) Appl. No.: **29/461,876**
- (22) Filed: **Jul. 29, 2013**

- D335,078 S * 4/1993 Hampshire D8/395
- D351,391 S * 10/1994 Martin D14/225
- D355,915 S * 2/1995 Chan D14/225
- D383,758 S * 9/1997 Emerson et al. D14/228
- D416,912 S * 11/1999 Hsieh D14/225

(Continued)

- (30) **Foreign Application Priority Data**
- Jan. 30, 2013 (JP) 2013-001693
- (51) **LOC (10) Cl.** **14-01**
- (52) **U.S. Cl.**
- USPC **D14/226**; D17/99
- (58) **Field of Classification Search**
- CPC H04R 1/46; H04R 15/00; H04R 17/00;
G10H 2220/175; G10H 2220/461
- USPC D14/155, 158, 159, 137, 185, 186, 188,
D14/191, 192, 204, 210, 212, 214–219, 221,
D14/225–229, 240, 416; D13/153, 168;
381/91, 118, 122, 355, 357, 358, 163,
381/191, 153, 157, 161, 361; 379/420.04;
73/584; D17/20, 99; 84/454, 723, 726;
D8/72, 395
- See application file for complete search history.

OTHER PUBLICATIONS

Korg Clip-On Microphone—Black (Tuning Accessories). Amazon.com [online] 5 pages. Posted Jul. 24, 2013 [retrieved on Aug. 5, 2014]. Retrieved from Internet: <http://www.amazon.com/Korg-KORG-CM200BK-Clip-On-Microphone-Black/dp/B00CPG43LO/ref=pd_cp_MI_1>.*

Primary Examiner — Susan Bennett Hattan
Assistant Examiner — Marie Fast Horse
(74) *Attorney, Agent, or Firm* — Adams & Wilks

- (56) **References Cited**
- U.S. PATENT DOCUMENTS
- 2,455,567 A * 12/1948 De Armond 84/726
- 2,486,263 A * 10/1949 De Armond 84/726
- 4,495,641 A * 1/1985 Vernino 381/91
- D286,013 S * 10/1986 Adams D8/395
- 4,748,886 A * 6/1988 De Byl 84/723
- D299,921 S * 2/1989 Kikutani D14/227
- D306,876 S * 3/1990 Greenhut et al. D19/65

(57) **CLAIM**
The ornamental design for pickup microphone, as shown and described.

DESCRIPTION

FIG. 1 is a front perspective view of a pickup microphone showing my new design;
FIG. 2 is a front view thereof;
FIG. 3 is a rear view thereof;
FIG. 4 is a right side view thereof;
FIG. 5 is a top plan view thereof;
FIG. 6 is a bottom view thereof;
FIG. 7 is a front perspective view thereof in a state where a clip is open; and,
FIG. 8 is a front perspective view thereof showing a use state. The left side view is omitted as being symmetric with the right side view.
The broken lines in FIG. 3 represent the portions of the pickup microphone, while, in FIG. 8, the broken lines represent environment; all areas shown in broken line form no part of the claim.

1 Claim, 4 Drawing Sheets

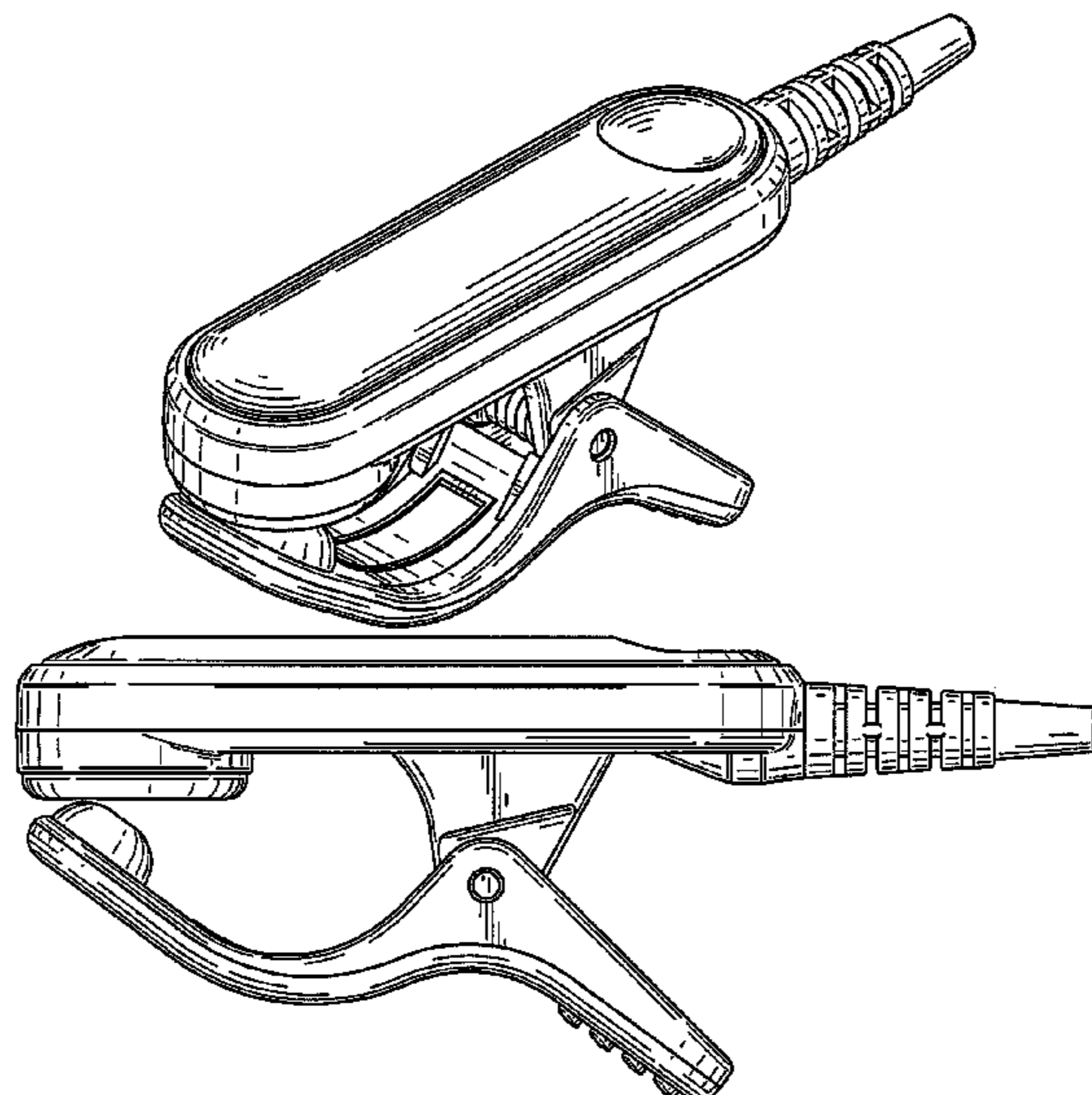

(56)

References Cited

U.S. PATENT DOCUMENTS

D453,506 S * 2/2002 Liou et al. D14/225
 6,526,142 B1 * 2/2003 Fan 379/420.04
 D477,029 S * 7/2003 Korowitz D19/78
 D492,289 S * 6/2004 Latti et al. D14/225
 7,049,502 B2 * 5/2006 Taku et al. 84/454
 D548,960 S * 8/2007 Tages et al. D3/218
 D572,205 S * 7/2008 Landerholm et al. D13/168
 D576,612 S * 9/2008 Wilson et al. D14/228
 D588,584 S * 3/2009 Park et al. D14/226
 D593,546 S * 6/2009 Tkachuk D14/223
 D593,609 S * 6/2009 Blau D19/65
 D598,278 S * 8/2009 Herman D8/395
 D608,767 S * 1/2010 Liner D14/225
 D613,273 S * 4/2010 Liner et al. D14/223

D629,837 S * 12/2010 Ishihara et al. D17/20
 D635,125 S * 3/2011 Nousiainen D14/223
 RE42,686 E * 9/2011 Shimizu D13/168
 D656,924 S * 4/2012 Mehlsen et al. D14/226
 D667,382 S * 9/2012 Cosentino et al. D13/168
 D682,256 S * 5/2013 Murchison et al. D14/223
 D684,849 S * 6/2013 Bylsma D8/395
 D688,301 S * 8/2013 Ando D17/20
 D697,779 S * 1/2014 Iwasaki D8/72
 D709,124 S * 7/2014 Ridinger et al. D17/99
 2008/0229905 A1 * 9/2008 Lau et al. 84/454
 2010/0005949 A1 * 1/2010 Calcagnini 84/454
 2010/0043624 A1 * 2/2010 Nagakura 84/454
 2011/0158452 A1 * 6/2011 Chen 381/361
 2012/0318063 A1 * 12/2012 Raguenet et al. 73/584
 2014/0069264 A1 * 3/2014 Bialkowski et al. 84/726

* cited by examiner

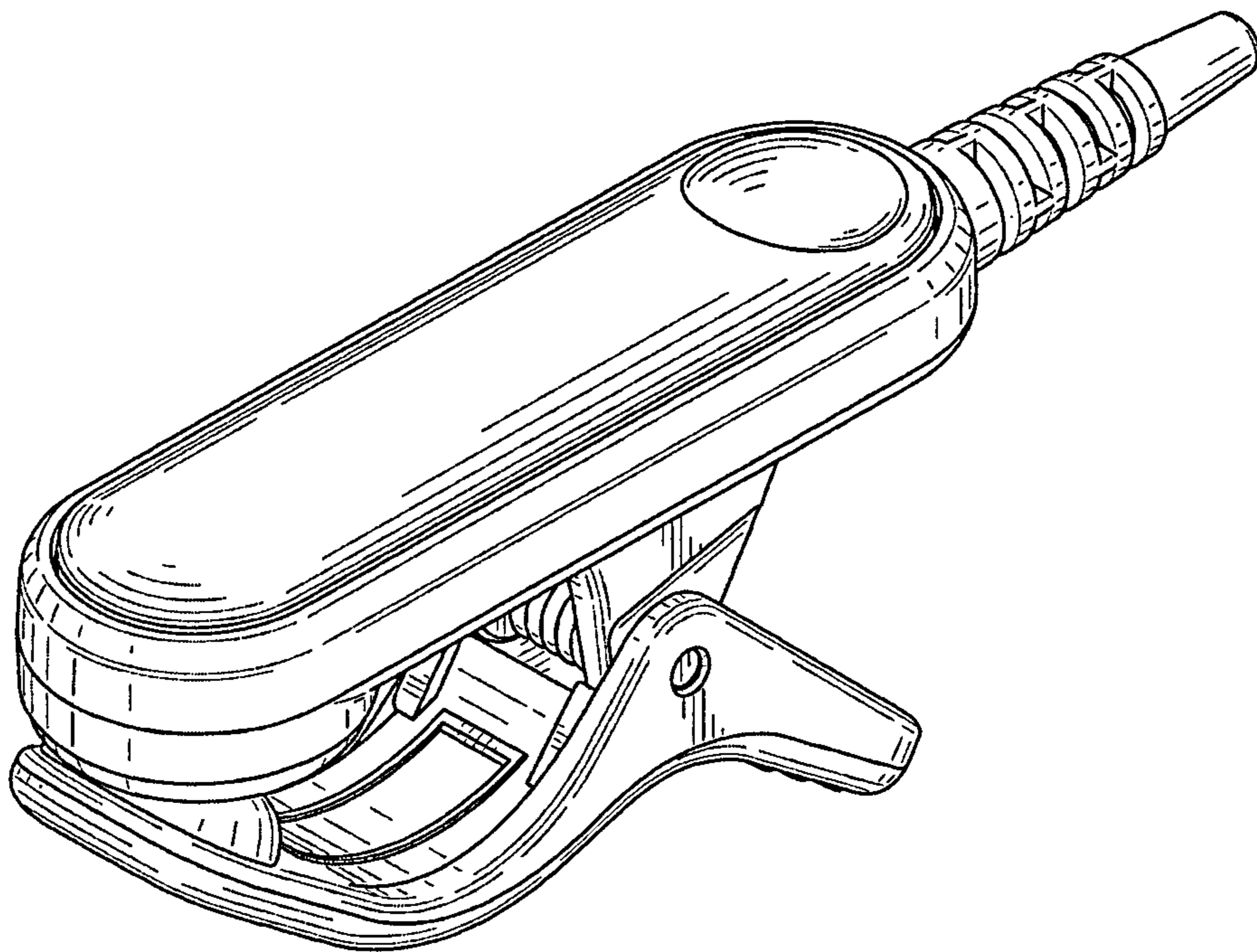

FIG. 1

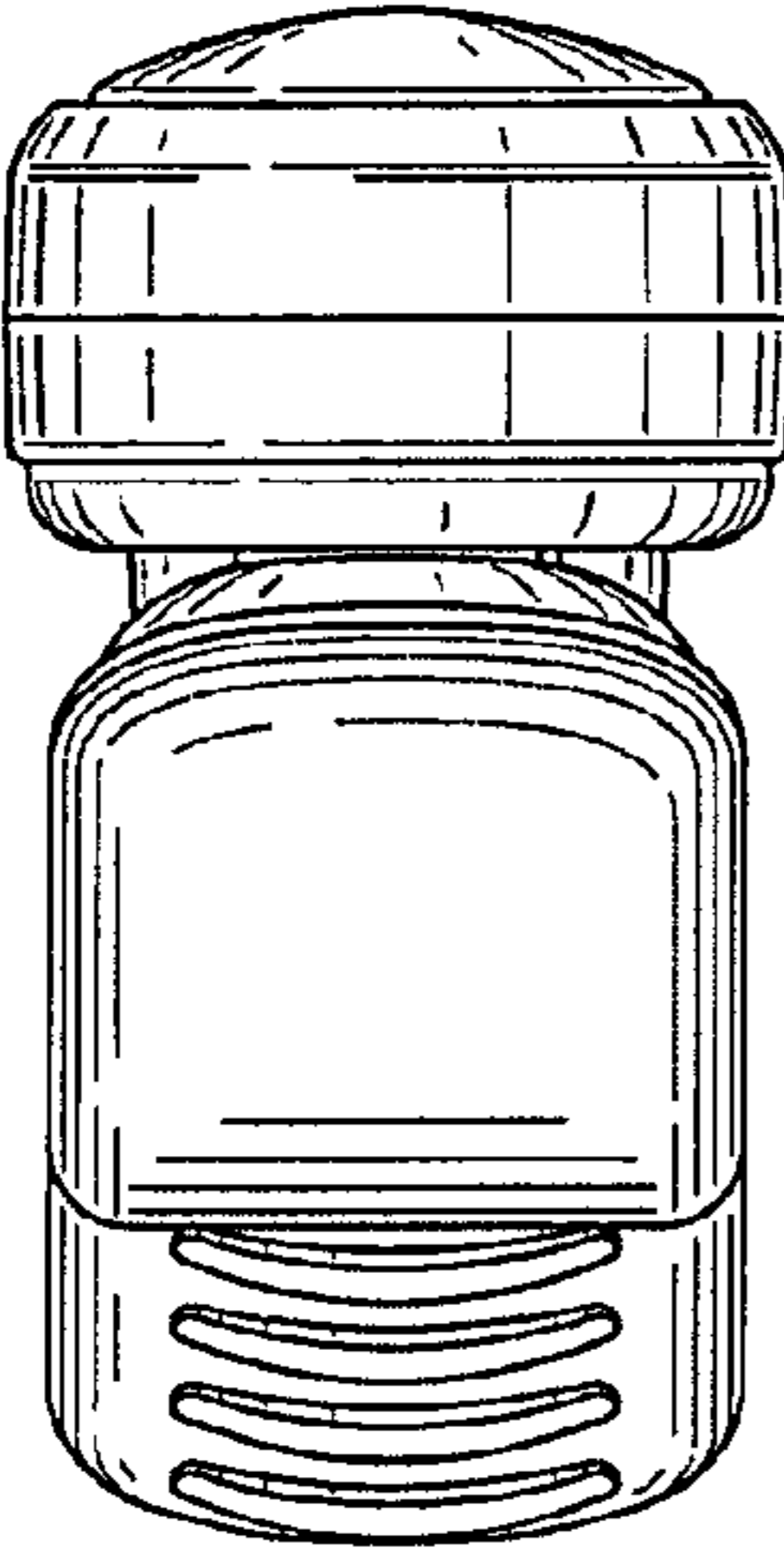

FIG. 2

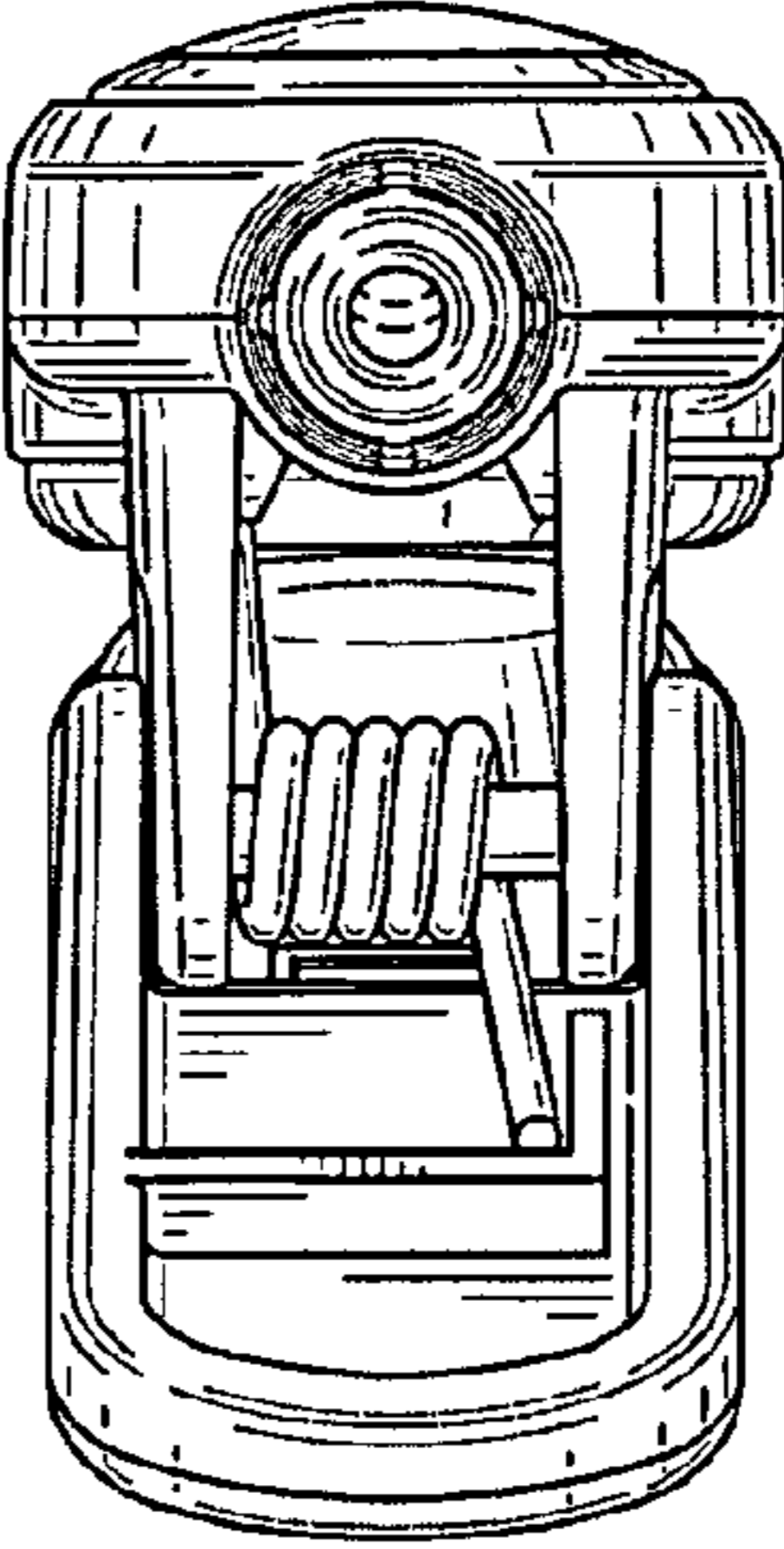

FIG. 3

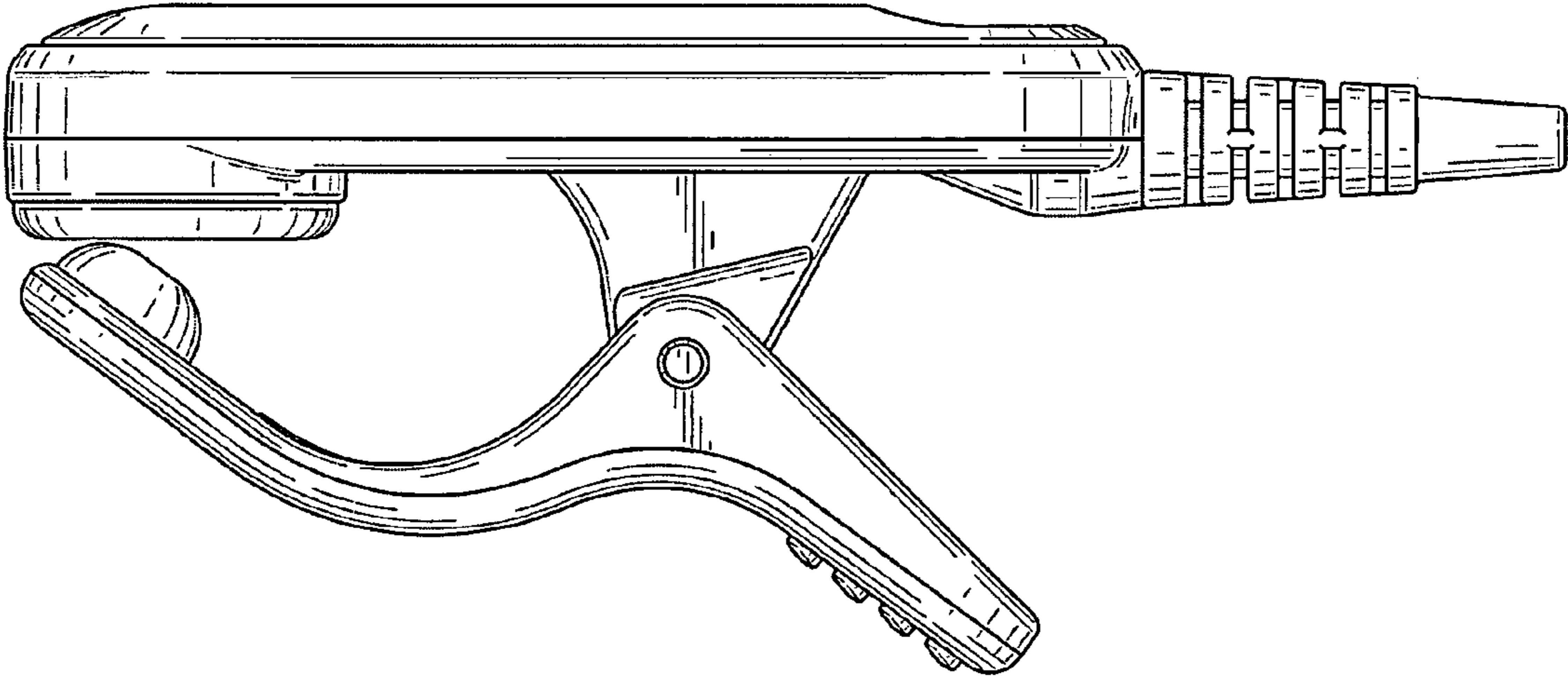

FIG. 4

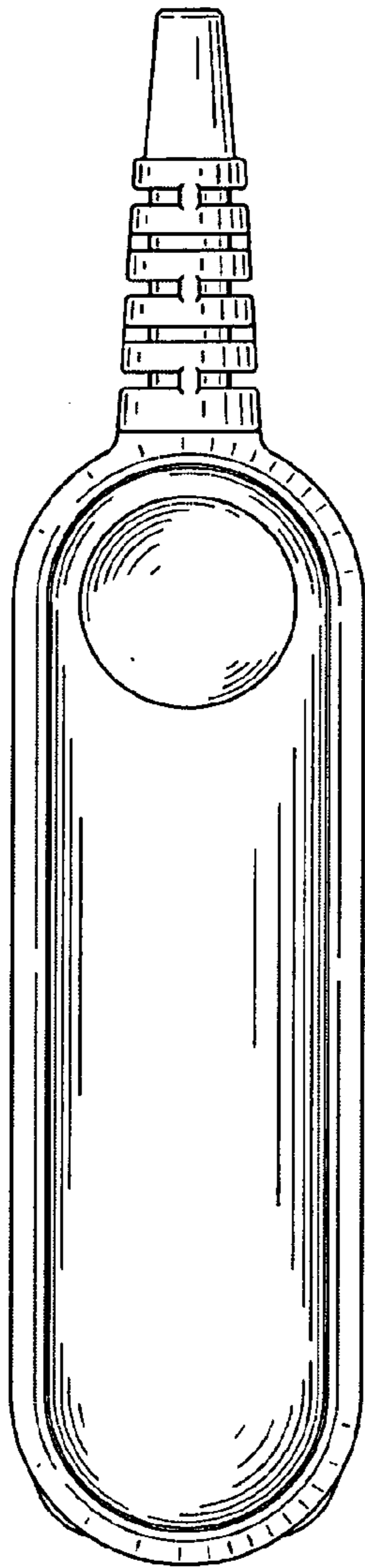

FIG. 5

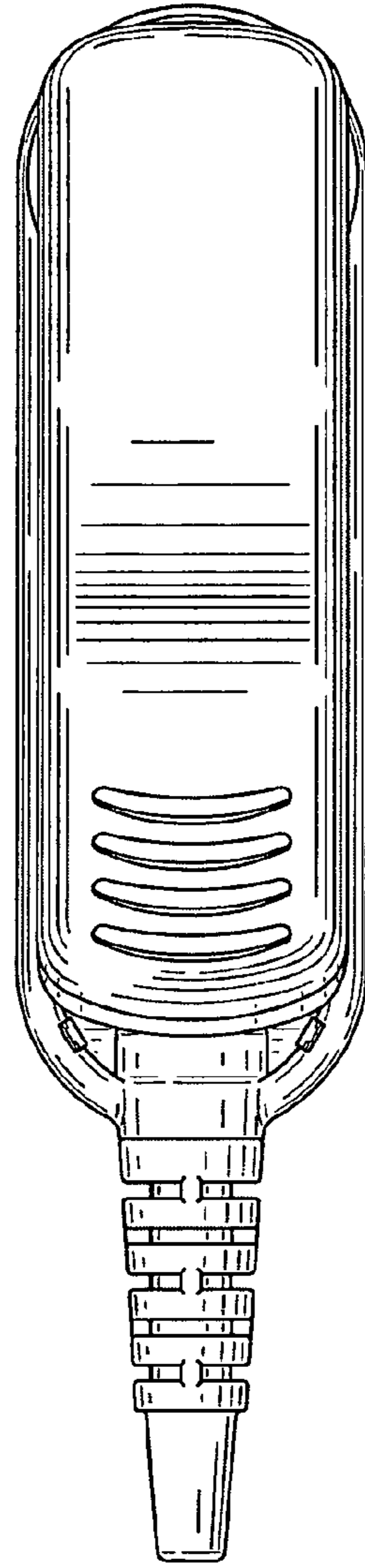

FIG. 6

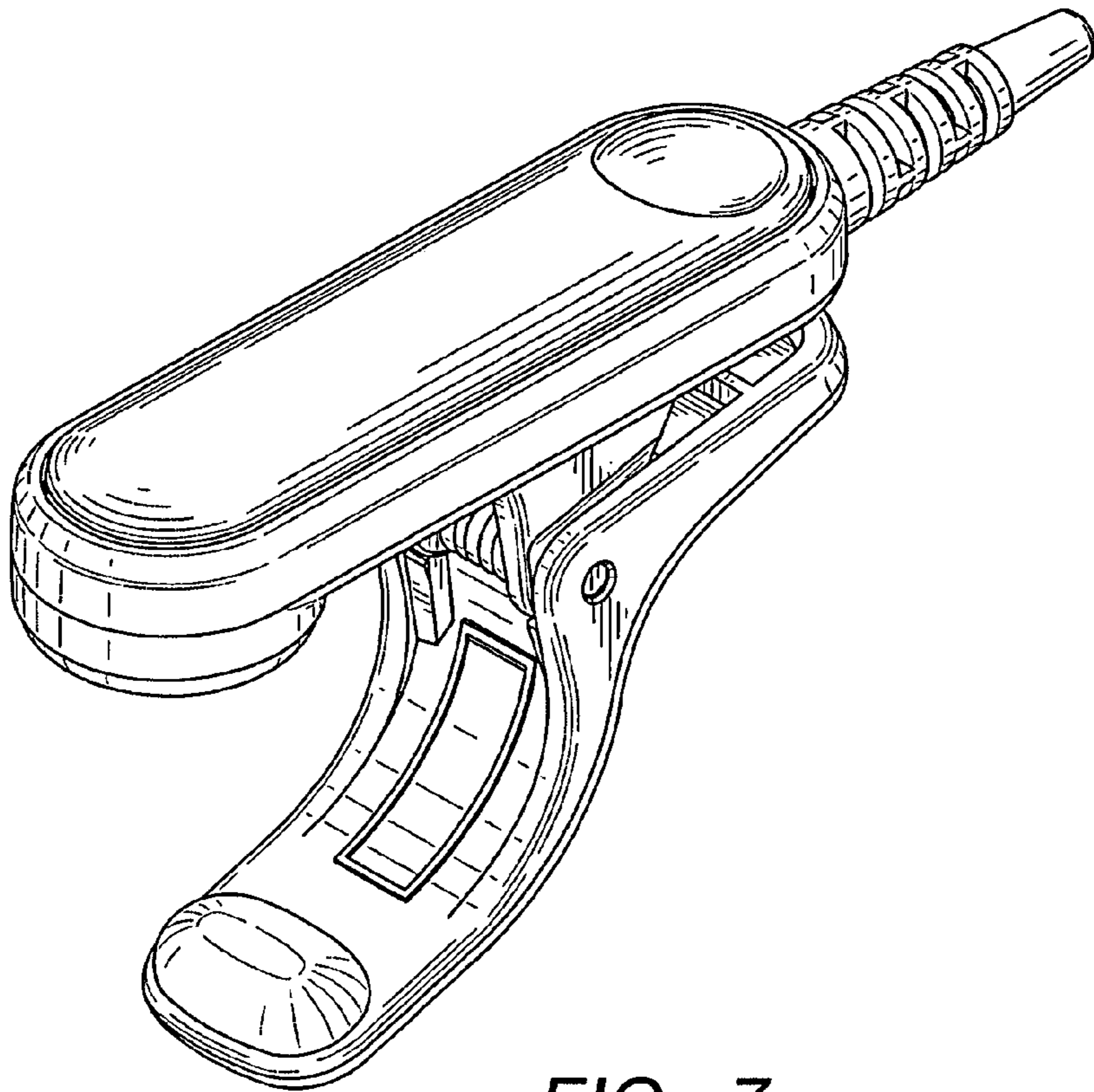

FIG. 7

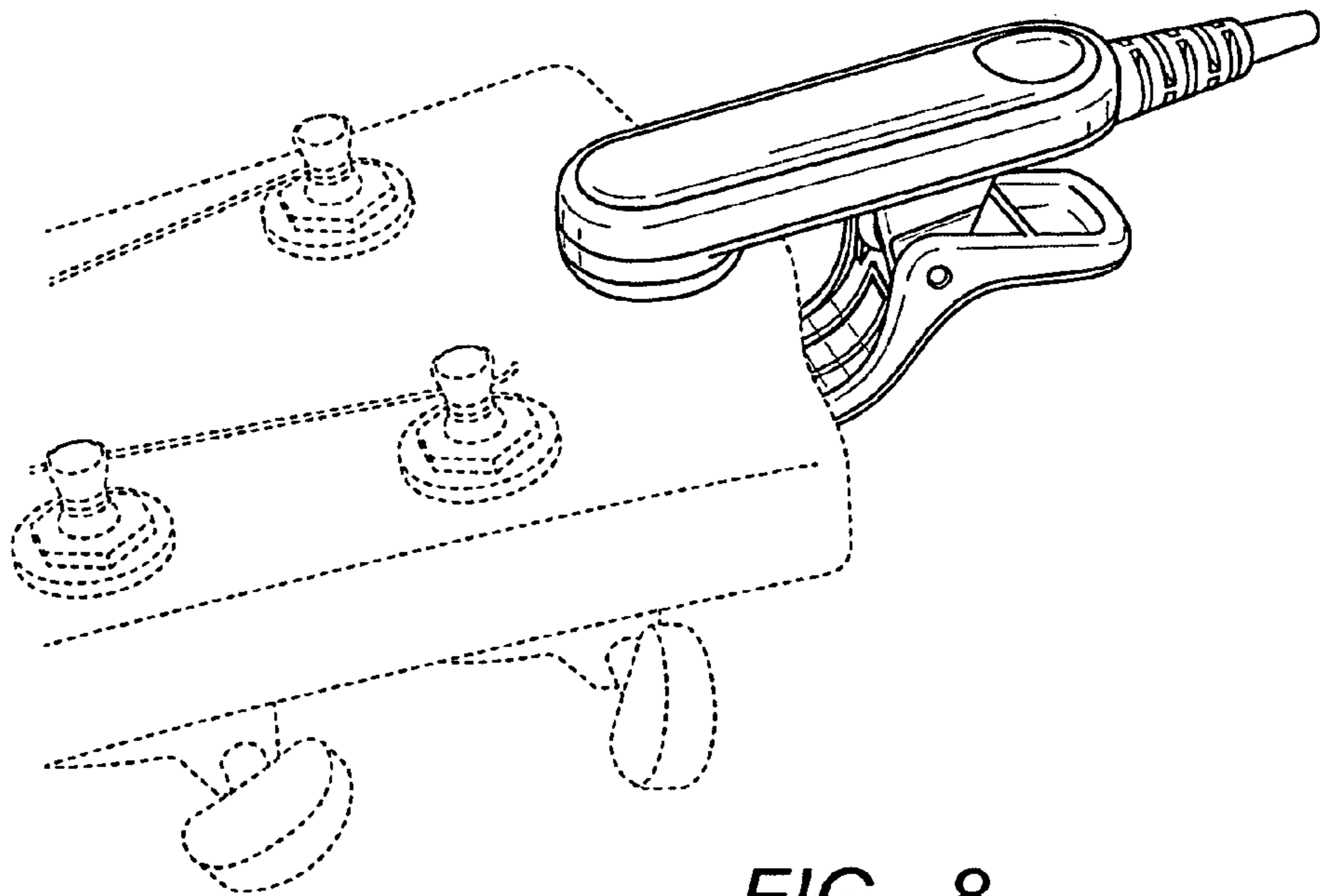

FIG. 8