



US00D719493S

(12) **United States Design Patent**  
**Mochinaga et al.**

(10) **Patent No.:** **US D719,493 S**  
(45) **Date of Patent:** **\*\* Dec. 16, 2014**

(54) **BEARING FOR A WHEEL, A PART OF A BEARING FOR A WHEEL, AND A HUB WHEEL OF A BEARING FOR A WHEEL**

8,568,036	B2 *	10/2013	Torii .....	384/544
8,585,298	B2 *	11/2013	Komori et al. ....	384/544
2013/0195389	A1 *	8/2013	Seki et al. ....	384/446
2013/0241270	A1 *	9/2013	Morita .....	301/110
2014/0010487	A1 *	1/2014	Seki et al. ....	384/446

(71) Applicant: **NTN Corporation**, Osaka (JP)

FOREIGN PATENT DOCUMENTS

(72) Inventors: **Shuji Mochinaga**, Shizuoka (JP);  
**Takayuki Norimatsu**, Shizuoka (JP)

JP	6-341494	12/1994
JP	11-82646	3/1999
JP	2006-289379	10/2006
JP	2006-327289	12/2006

(73) Assignee: **NTN Corporation**, Osaka (JP)

(\*\*) Term: **14 Years**

OTHER PUBLICATIONS

(21) Appl. No.: **29/440,776**

Japanese Office Action issued Aug. 17, 2012 in corresponding Japanese Patent Application No. 2012-015341 with English translation.

(22) Filed: **Dec. 27, 2012**

\* cited by examiner

(30) **Foreign Application Priority Data**

Jun. 28, 2012	(JP)	.....	2012-015340
Jun. 28, 2012	(JP)	.....	2012-015341
Jun. 28, 2012	(JP)	.....	2012-015342
Dec. 4, 2012	(JP)	.....	2012-029686
Dec. 4, 2012	(JP)	.....	2012-029687
Dec. 4, 2012	(JP)	.....	2012-029688

*Primary Examiner* — Michael A Pratt

(74) *Attorney, Agent, or Firm* — Wenderoth, Lind & Ponack, L.L.P.

(51) **LOC (10) Cl.** ..... **12-16**

(52) **U.S. Cl.**  
USPC ..... **D12/160**

(57) **CLAIM**

The ornamental design for a bearing for a wheel, a part of a bearing for a wheel, and a hub wheel of a bearing for a wheel, as shown and described.

(58) **Field of Classification Search**  
USPC ..... D12/160; 280/11.225, 86.752, 104, 280/124.145–124.147, 124.155, 676, 677, 280/681, 682, 687; 267/64.15, 136, 195, 267/217; 188/274, 281, 286, 297–298, 188/315–316; 464/173; 293/134  
See application file for complete search history.

**DESCRIPTION**

FIG. 1 illustrates a front view of a bearing for a wheel according to a first embodiment;  
FIG. 2 illustrates a rear view of the bearing for the wheel according to the first embodiment;  
FIG. 3 illustrates a top view of the bearing for the wheel according to the first embodiment;  
FIG. 4 illustrates a bottom view of the bearing for the wheel according to the first embodiment;  
FIG. 5 illustrates a right side view of the bearing for the wheel according to the first embodiment;  
FIG. 6 illustrates a reference front view of the bearing for the wheel according to the first embodiment;  
FIG. 7 illustrates a combined sectional view taken along line A-B-C in FIG. 6 of the bearing for the wheel according to the first embodiment;

(56) **References Cited**

U.S. PATENT DOCUMENTS

4,878,683	A *	11/1989	Dever .....	180/253
6,398,240	B1 *	6/2002	Taylor .....	280/93.512
D462,256	S *	9/2002	Jaynes .....	D8/382
8,511,903	B2 *	8/2013	Masuda et al. ....	384/544
8,534,924	B2 *	9/2013	Zwarts et al. ....	384/544
8,556,737	B2 *	10/2013	Yamauchi et al. ....	464/178

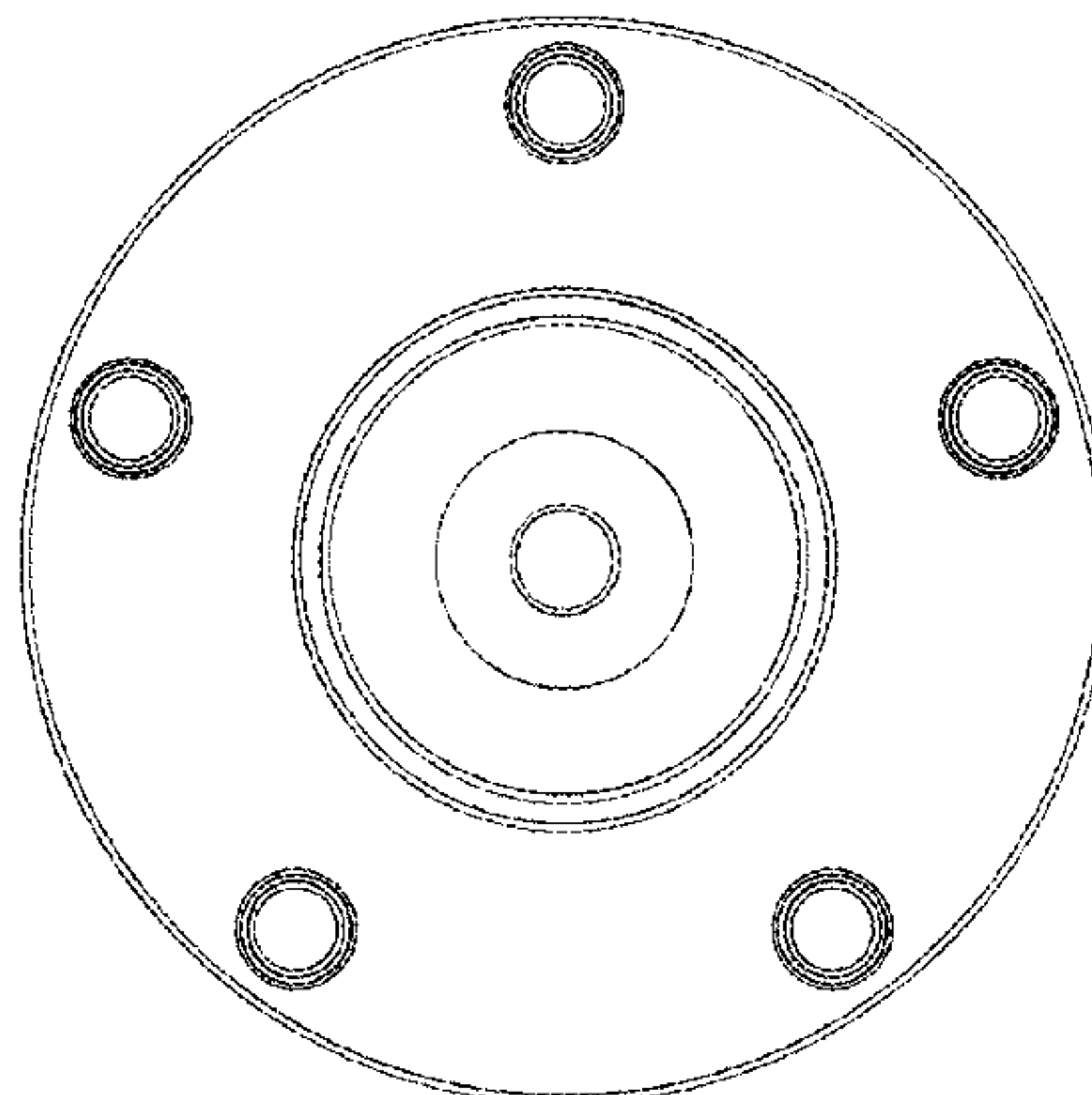



FIG. 8 illustrates an enlarged view of portions D, E in FIG. 7 of the bearing for the wheel according to the first embodiment;

FIG. 9 illustrates a sectional view taken along line F-G in FIG. 8 of the bearing for the wheel according to the first embodiment;

FIG. 10 illustrates a sectional view taken along line H-I in FIG. 8 of the bearing for the wheel according to the first embodiment;

FIG. 11 illustrates a prospective view of the bearing for the wheel according to the first embodiment;

FIG. 12 illustrates a reference sectional view showing an assembled state in an automobile of the bearing for the wheel according to the first embodiment;

FIG. 13 illustrates a reference enlarged perspective view of the female teeth portion of the bearing for the wheel according to the first embodiment;

FIG. 14 illustrates a front view of a hub wheel of a bearing for a wheel according to a second embodiment;

FIG. 15 illustrates a rear view of the hub wheel of the bearing for the wheel according to the second embodiment;

FIG. 16 illustrates a top view of the hub wheel of the bearing for the wheel according to the second embodiment;

FIG. 17 illustrates a bottom view of the hub wheel of the bearing for the wheel according to the second embodiment;

FIG. 18 illustrates a right side view of the hub wheel of the bearing for the wheel according to the second embodiment;

FIG. 19 illustrates a sectional view taken along line A-A in FIG. 14 of the hub wheel of the bearing for the wheel according to the second embodiment;

FIG. 20 illustrates an enlarged view of portions B, B in FIG. 19 of the hub wheel of the bearing for the wheel according to the second embodiment;

FIG. 21 illustrates a sectional view taken along line C-D in FIG. 20 of the hub wheel of the bearing for the wheel according to the second embodiment;

FIG. 22 illustrates a sectional view taken along line E-F in FIG. 20 of the hub wheel of the bearing for the wheel according to the second embodiment;

FIG. 23 illustrates a prospective view of the hub wheel of the bearing for the wheel according to the second embodiment;

FIG. 24 illustrates a reference sectional view showing an assembled state in an automobile of the hub wheel of the bearing for the wheel according to the second embodiment;

FIG. 25 illustrates a reference enlarged perspective view of the female teeth portion of the hub wheel of the bearing for the wheel according to the second embodiment;

FIG. 26 illustrates a front view of a bearing for a wheel according to a third embodiment;

FIG. 27 illustrates a rear view of the bearing for the wheel according to the third embodiment;

FIG. 28 illustrates a top view of the bearing for the wheel according to the third embodiment;

FIG. 29 illustrates a bottom view of the bearing for the wheel according to the third embodiment;

FIG. 30 illustrates a right side view of the bearing for the wheel according to the third embodiment;

FIG. 31 illustrates a reference front view of the bearing for the wheel according to the third embodiment;

FIG. 32 illustrates a combined sectional view taken along line A-B-C in FIG. 31 of the bearing for the wheel according to the third embodiment;

FIG. 33 illustrates an enlarged view of portions D, E in FIG. 32 of the bearing for the wheel according to the third embodiment;

FIG. 34 illustrates a sectional view taken along line F-G in FIG. 33 of the bearing for the wheel according to the third embodiment;

FIG. 35 illustrates a sectional view taken along line H-I in FIG. 33 of the bearing for the wheel according to the third embodiment;

FIG. 36 illustrates a prospective view of the bearing for the wheel according to the third embodiment;

FIG. 37 illustrates a reference sectional view showing an assembled state in an automobile of the bearing for the wheel according to the third embodiment;

FIG. 38 illustrates a reference enlarged perspective view of the female teeth portion of the bearing for the wheel according to the third embodiment;

FIG. 39 illustrates a front view of a bearing for a wheel according to a fourth embodiment;

FIG. 40 illustrates a rear view of the bearing for the wheel according to the fourth embodiment;

FIG. 41 illustrates a top view of the bearing for the wheel according to the fourth embodiment;

FIG. 42 illustrates a bottom view of the bearing for the wheel according to the fourth embodiment;

FIG. 43 illustrates a right side view of the bearing for the wheel according to the fourth embodiment;

FIG. 44 illustrates a reference front view of the bearing for the wheel according to the fourth embodiment;

FIG. 45 illustrates a combined sectional view taken along line A-B-C in FIG. 44 of the bearing for the wheel according to the fourth embodiment;

FIG. 46 illustrates an enlarged view of portions D, E in FIG. 45 of the bearing for the wheel according to the fourth embodiment;

FIG. 47 illustrates a sectional view taken along line F-G in FIG. 46 of the bearing for the wheel according to the fourth embodiment;

FIG. 48 illustrates a sectional view taken along line H-I in FIG. 46 of the bearing for the wheel according to the fourth embodiment;

FIG. 49 illustrates a prospective view of the bearing for the wheel according to the fourth embodiment;

FIG. 50 illustrates a reference sectional view showing an assembled state in an automobile of the bearing for the wheel according to the fourth embodiment;

FIG. 51 illustrates a reference enlarged perspective view of the female teeth portion of the bearing for the wheel according to the fourth embodiment;

FIG. 52 illustrates a front view of a bearing for a wheel according to a fifth embodiment;

FIG. 53 illustrates a rear view of the bearing for the wheel according to the fifth embodiment;

FIG. 54 illustrates a top view of the bearing for the wheel according to the fifth embodiment;

FIG. 55 illustrates a bottom view of the bearing for the wheel according to the fifth embodiment;

FIG. 56 illustrates a right side view of the bearing for the wheel according to the fifth embodiment;

FIG. 57 illustrates a reference front view of the bearing for the wheel according to the fifth embodiment;

FIG. 58 illustrates a combined sectional view taken along line A-B-C in FIG. 57 of the bearing for the wheel according to the fifth embodiment;

FIG. 59 illustrates an enlarged view of portions D, E in FIG. 58 of the bearing for the wheel according to the fifth embodiment;

FIG. 60 illustrates a sectional view taken along line F-G in FIG. 59 of the bearing for the wheel according to the fifth embodiment;

FIG. 61 illustrates a sectional view taken along line H-I in FIG. 59 of the bearing for the wheel according to the fifth embodiment;

FIG. 62 illustrates a prospective view of the bearing for the wheel according to the fifth embodiment;

FIG. 63 illustrates a reference sectional view showing an assembled state in an automobile of the bearing for the wheel according to the fifth embodiment; and,

FIG. 64 illustrates a reference enlarged perspective view of the female teeth portion of the bearing for the wheel according to the fifth embodiment.

In the drawings, the portions indicated by solid lines are the portions for which a patent as a partial design is sought. The portions of the drawings illustrated with broken lines are not part of the claimed design.

In the drawings, the left side view is omitted because it is symmetrically shown in the right side view.

A bearing for a wheel supports a wheel of an automobile in a rotatable manner, and transmits a driving force of an engine or a motor to the wheel. A shaft portion of an outer joint member that configures a constant velocity universal joint is press-fitted into an inner circumference of a hub wheel. The inner circumference of the hub wheel has a female spline-shaped female teeth portion formed thereon, and after press-fitting the shaft portion of the outer joint member, a torque transmission between the shaft portion and the hub wheel is performed by a male spline-shaped male teeth portion formed on an outer circumferential surface of the shaft portion meshing with the female teeth portion. The female teeth portion of the hub wheel is composed of a fitting portion on an axially front side and a guide portion on an axially back side. Recess portions of the female teeth portion that extend in an axial direction have greater width and depth at the guide portion than at the fitting portion. A module  $M$ , defined by  $M = \text{PCD} [\text{mm}] / Z$ , of the female teeth portion is set to be smaller than 1.0. In the formula, "Z" represents number of teeth.

**1 Claim, 64 Drawing Sheets**



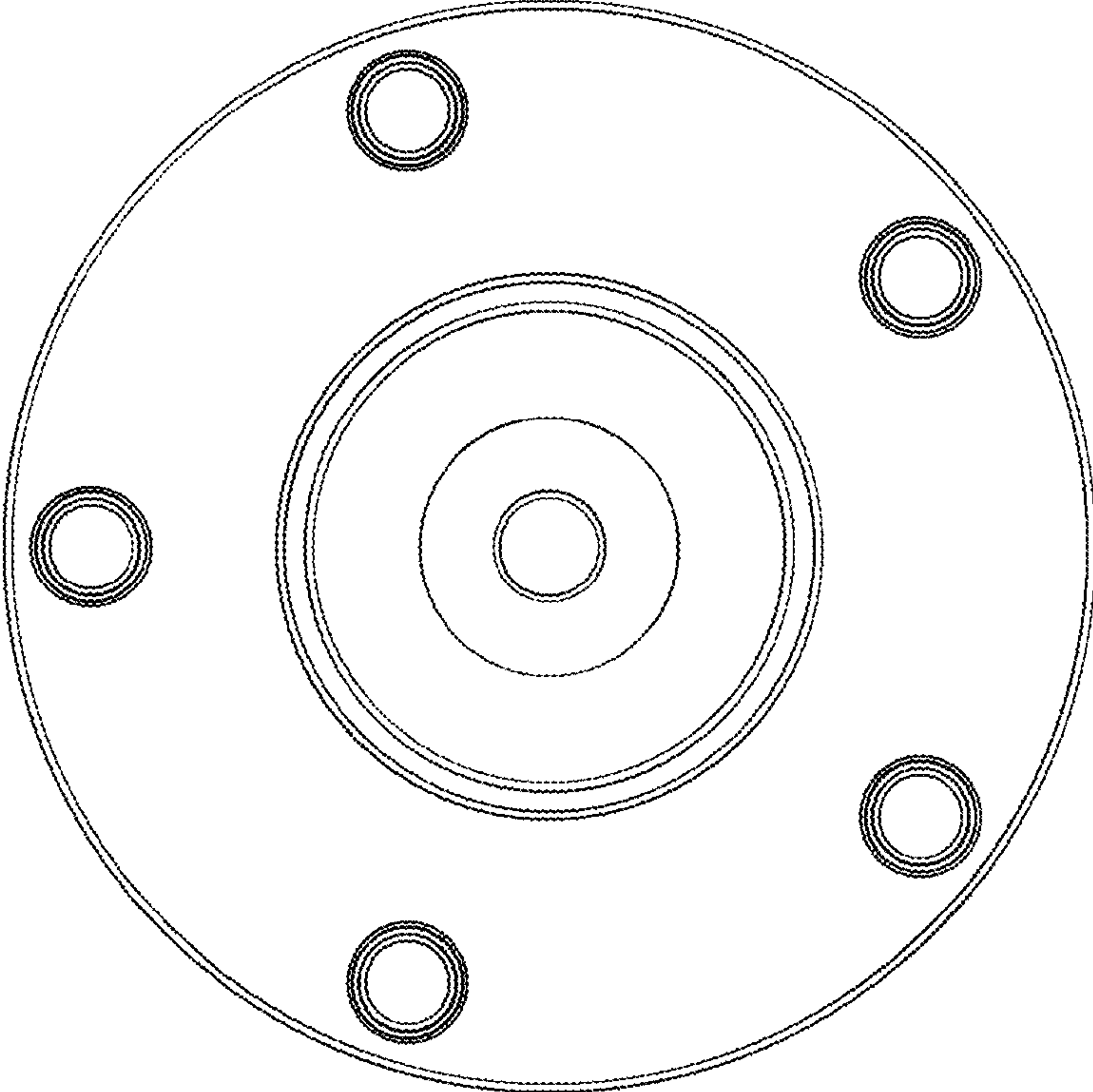

FIG. 1

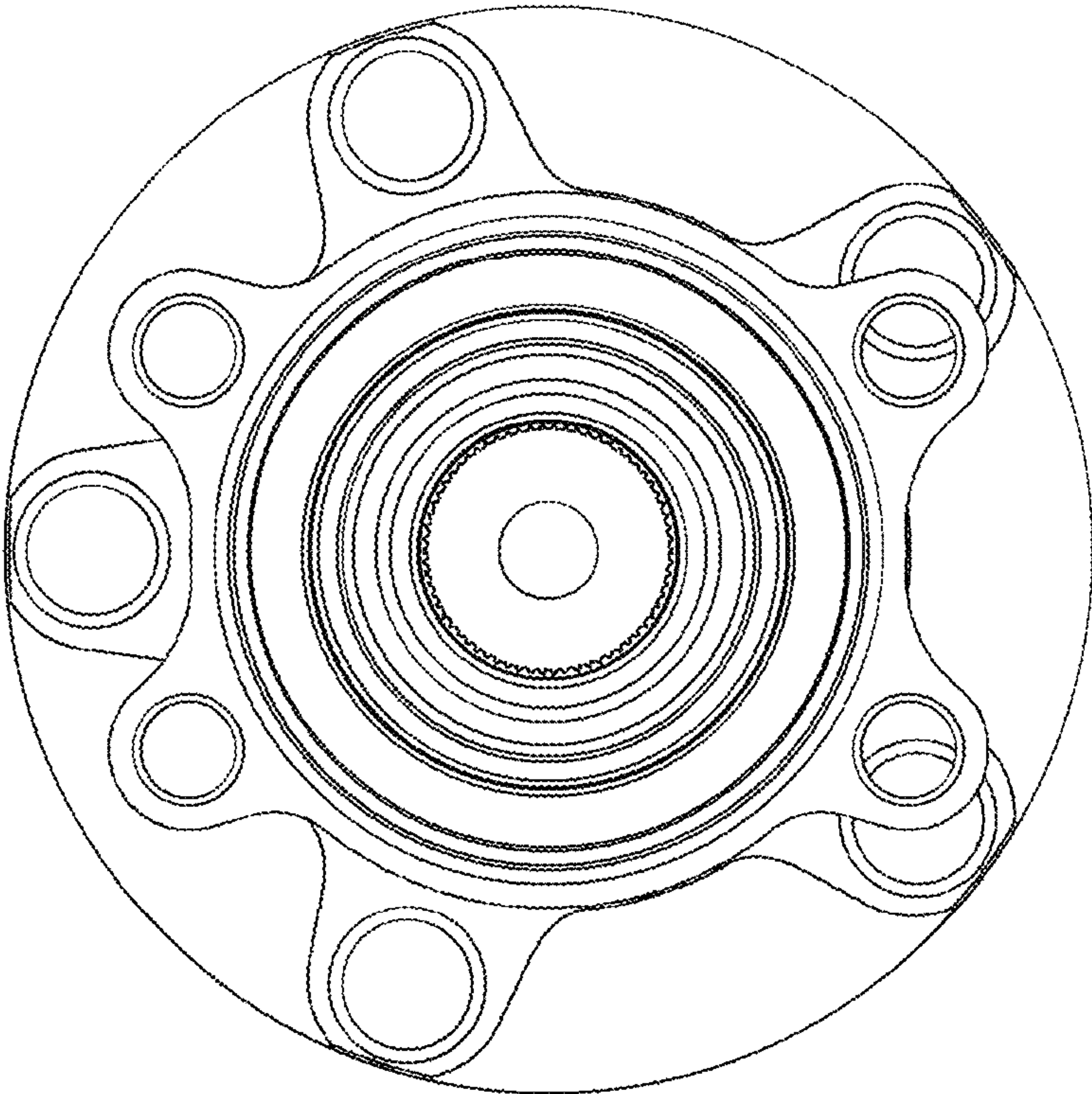

FIG. 2

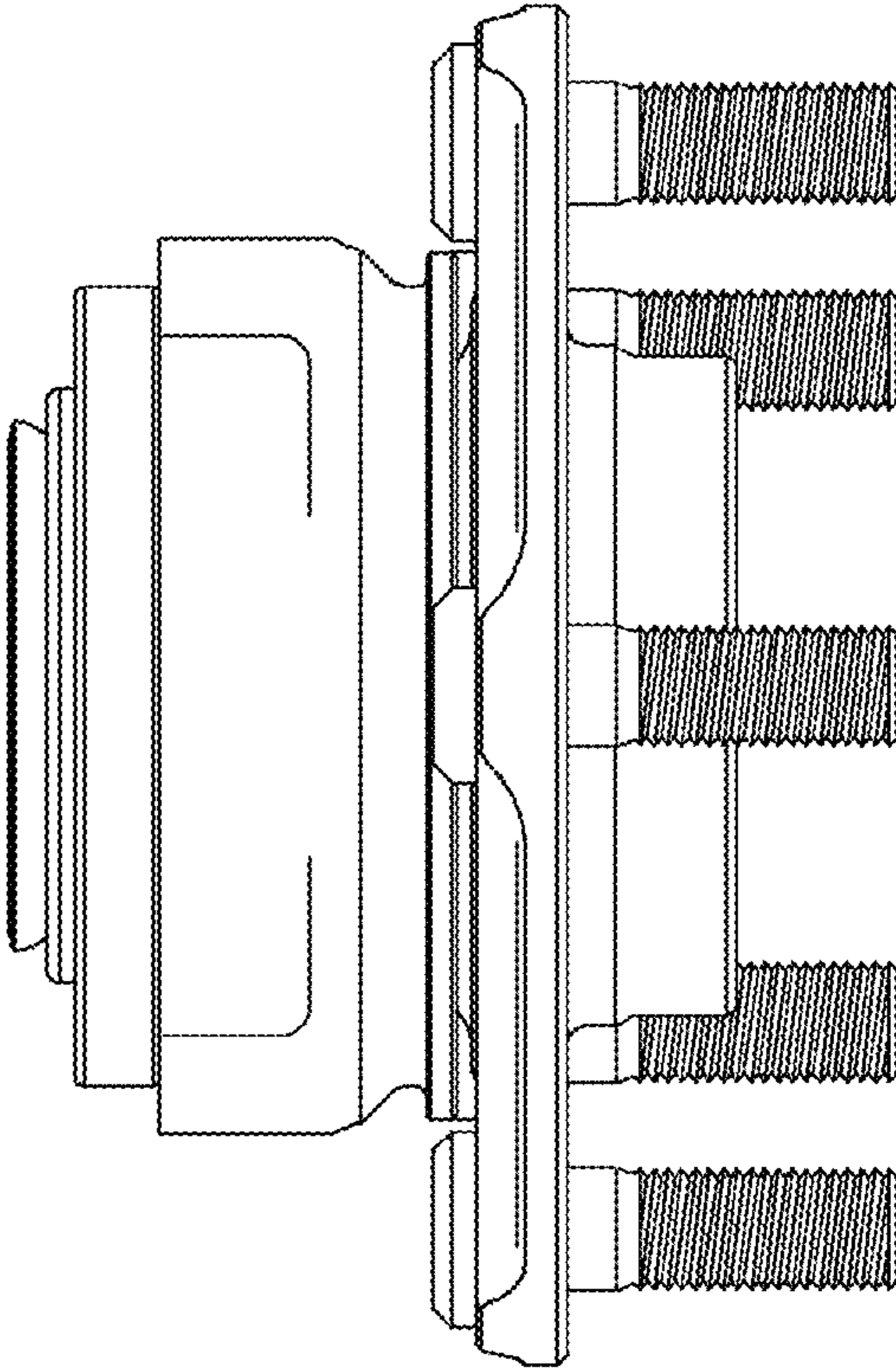

FIG. 3

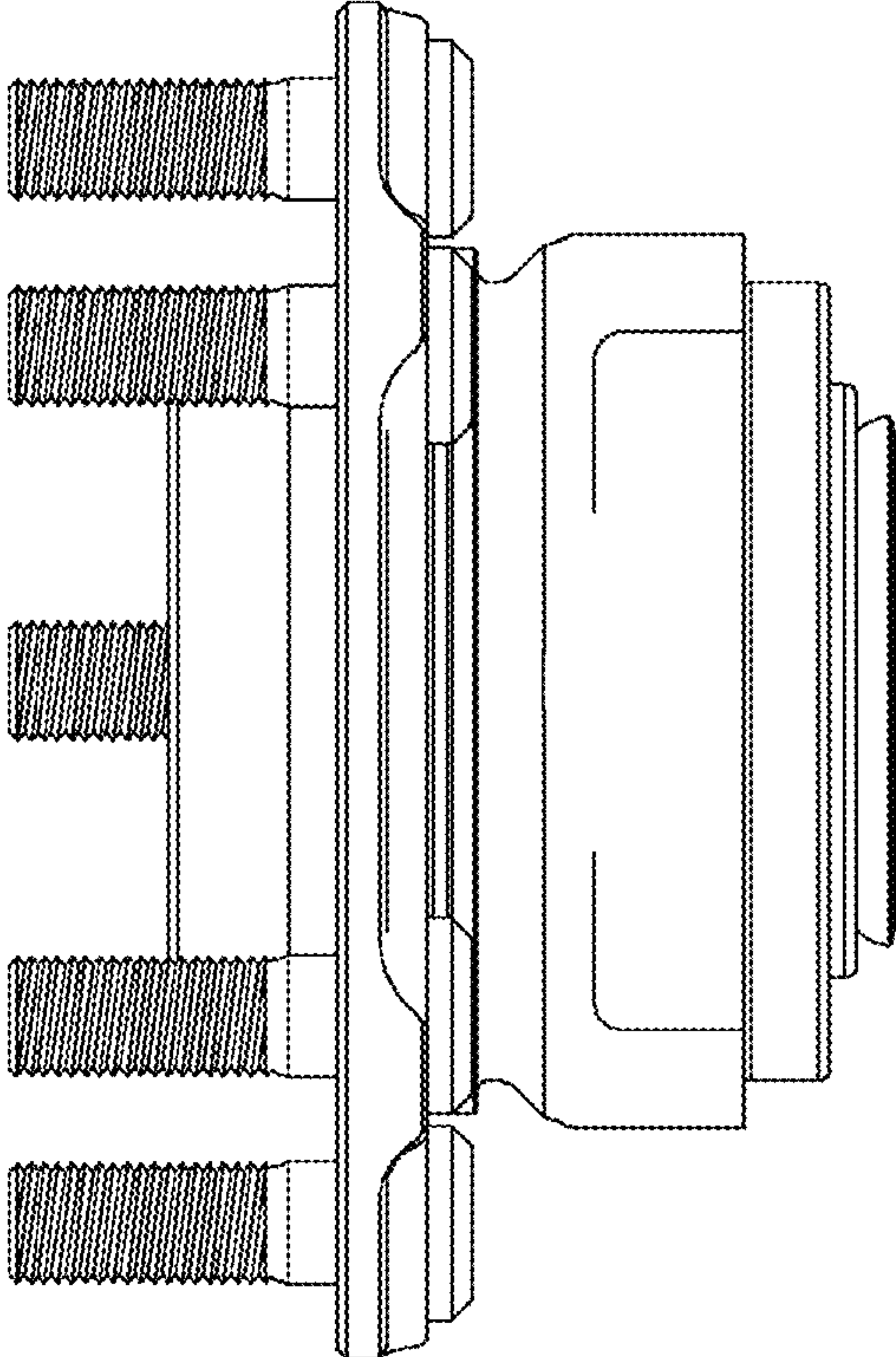
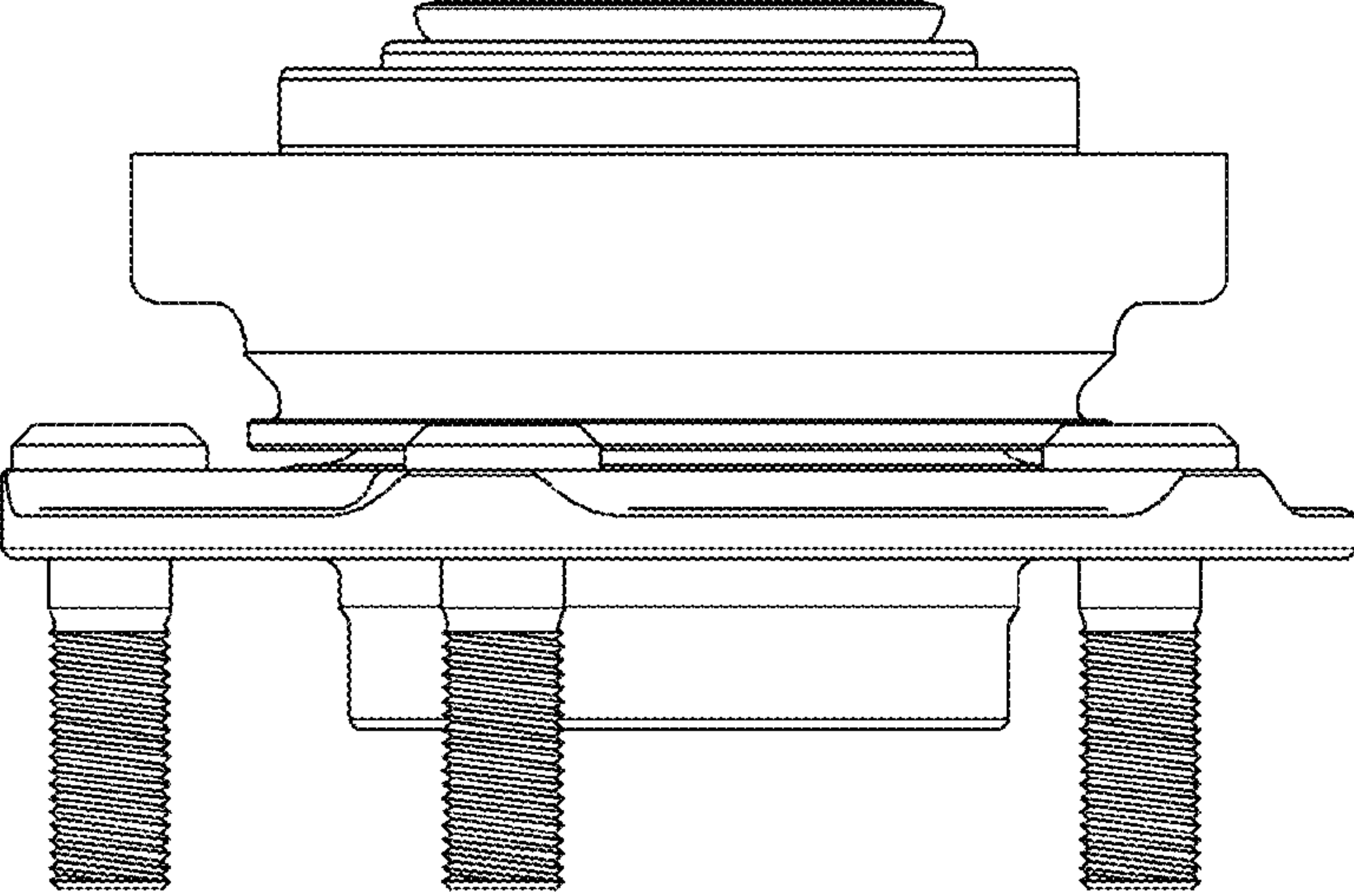

FIG. 4

FIG. 5





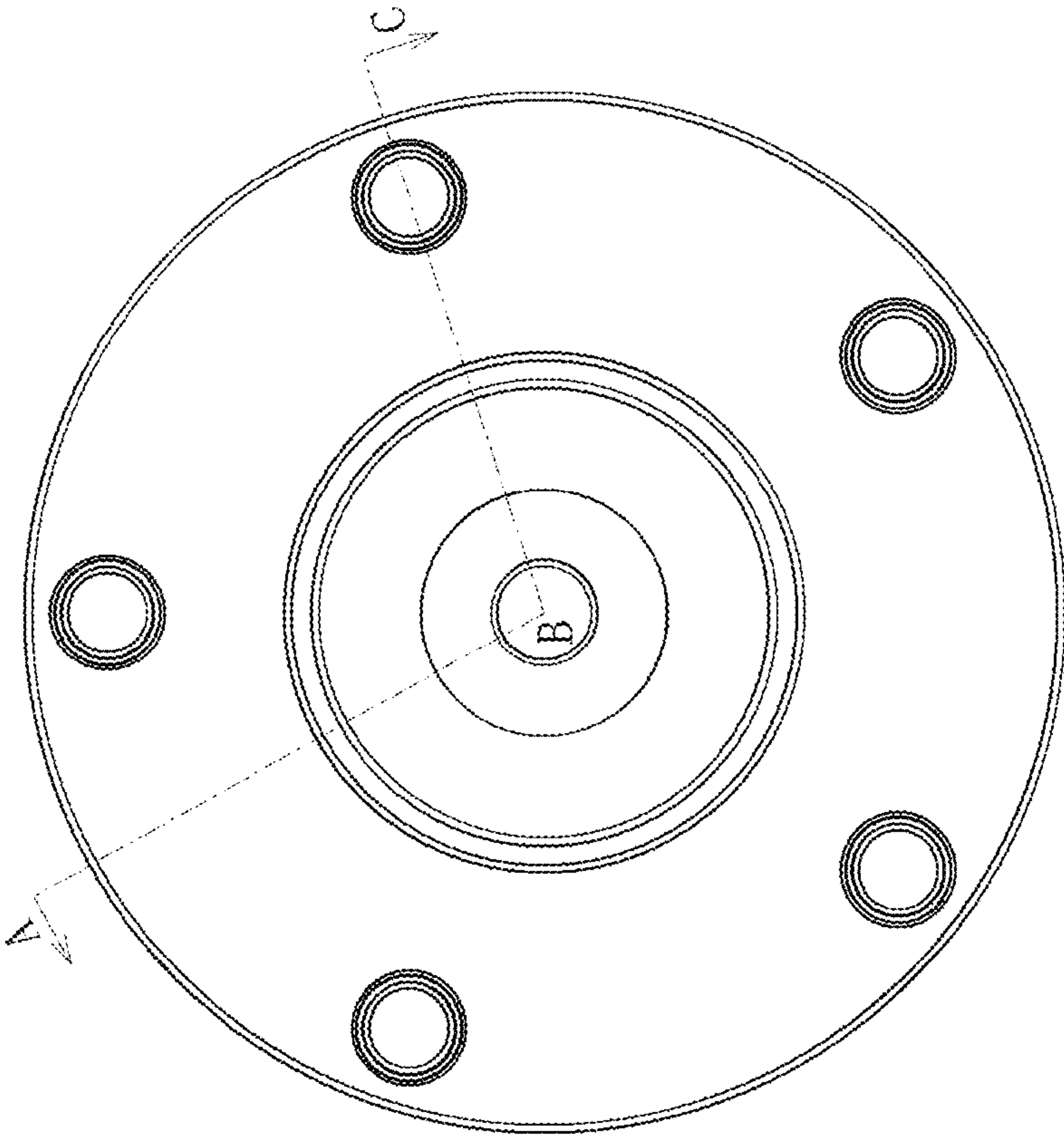

FIG. 6

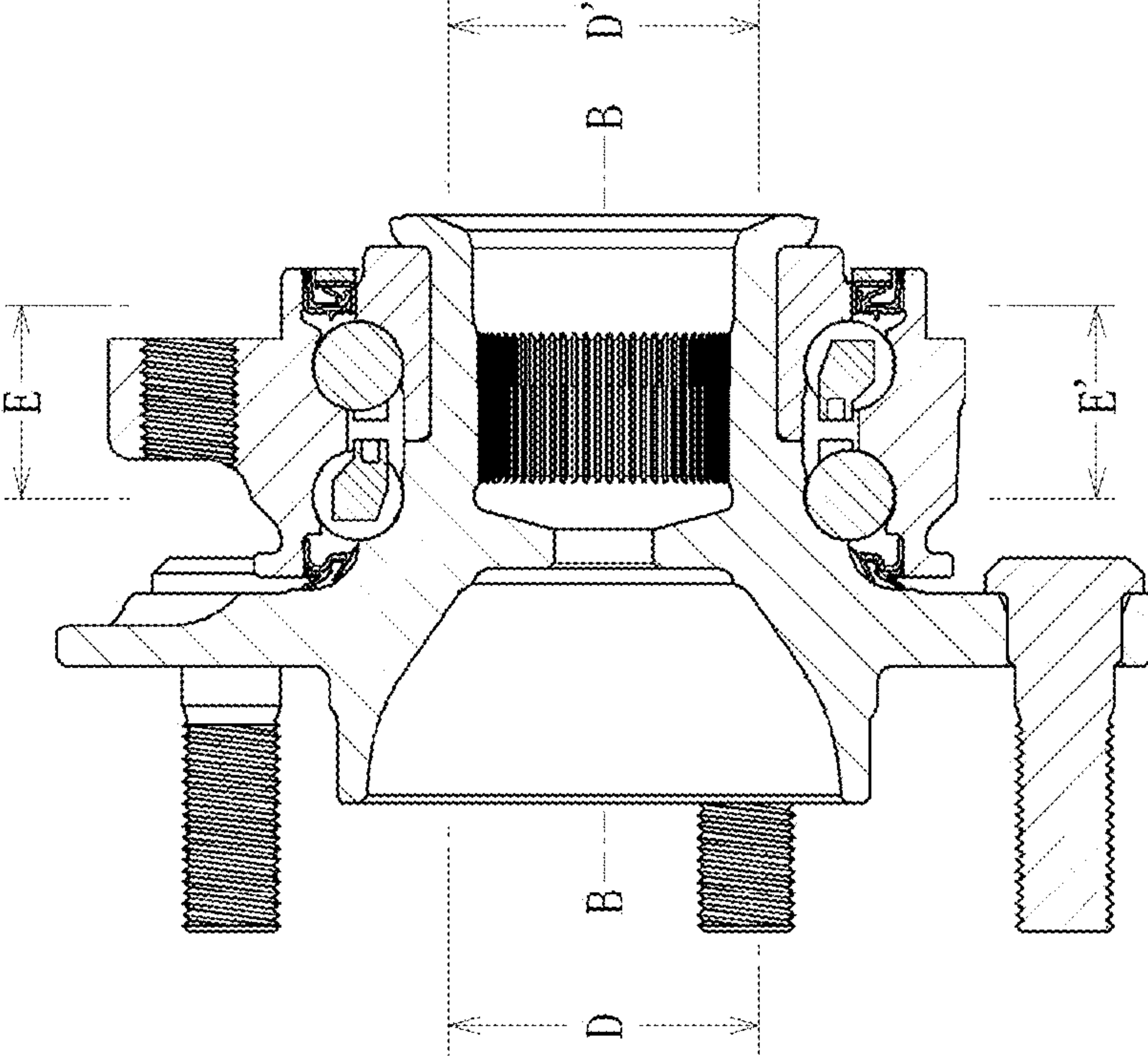

FIG. 7

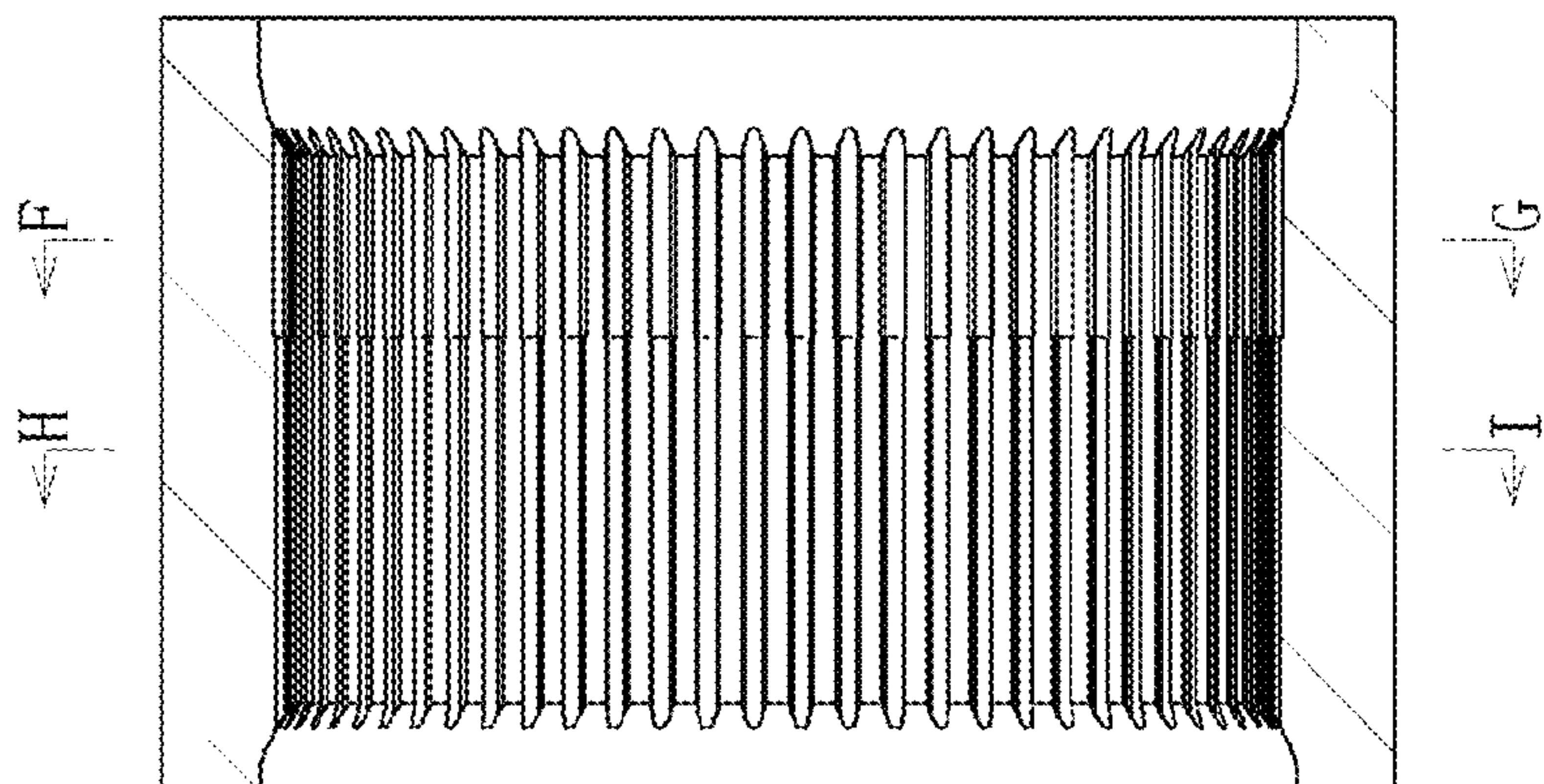

FIG. 8



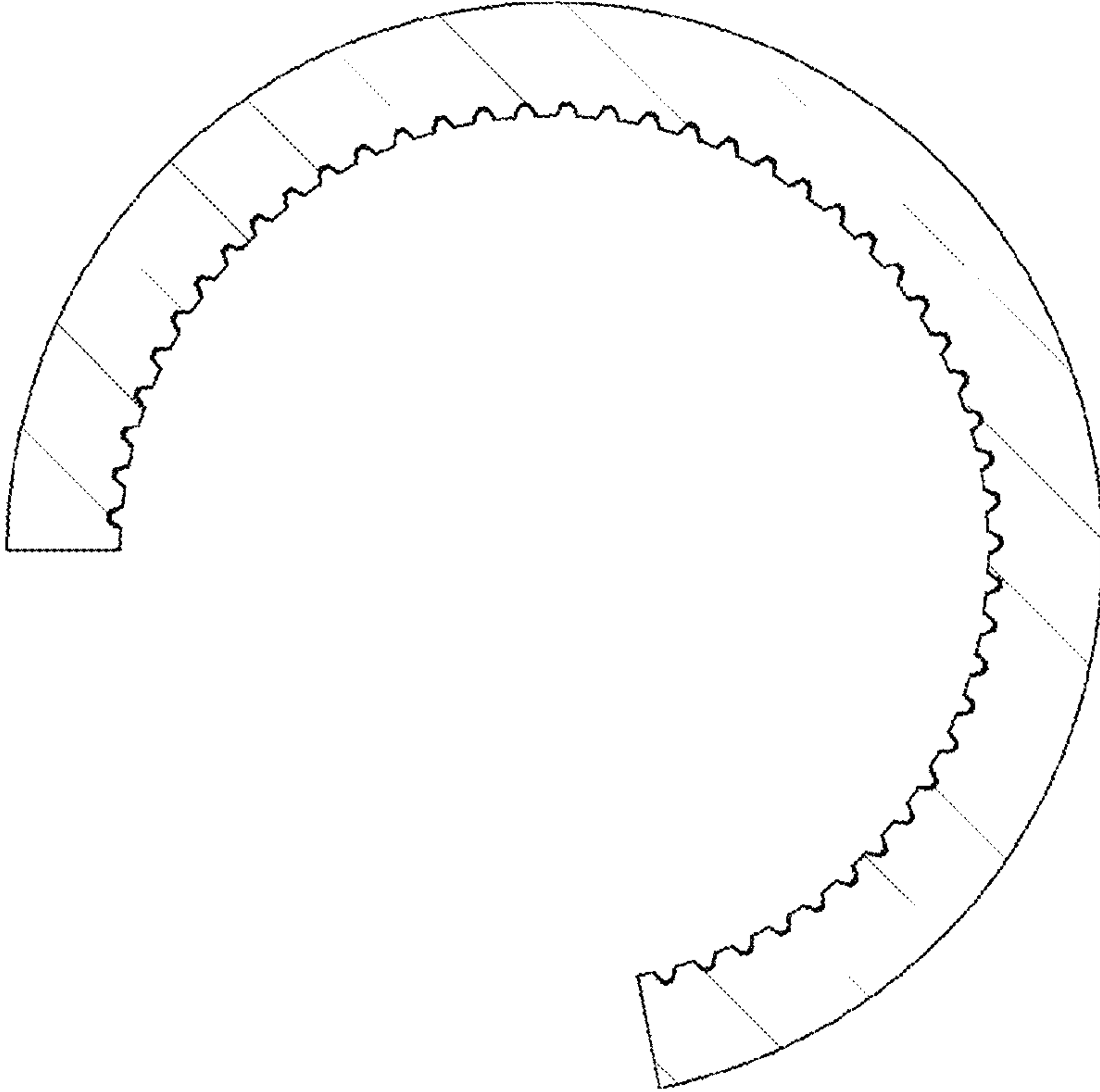

FIG. 9

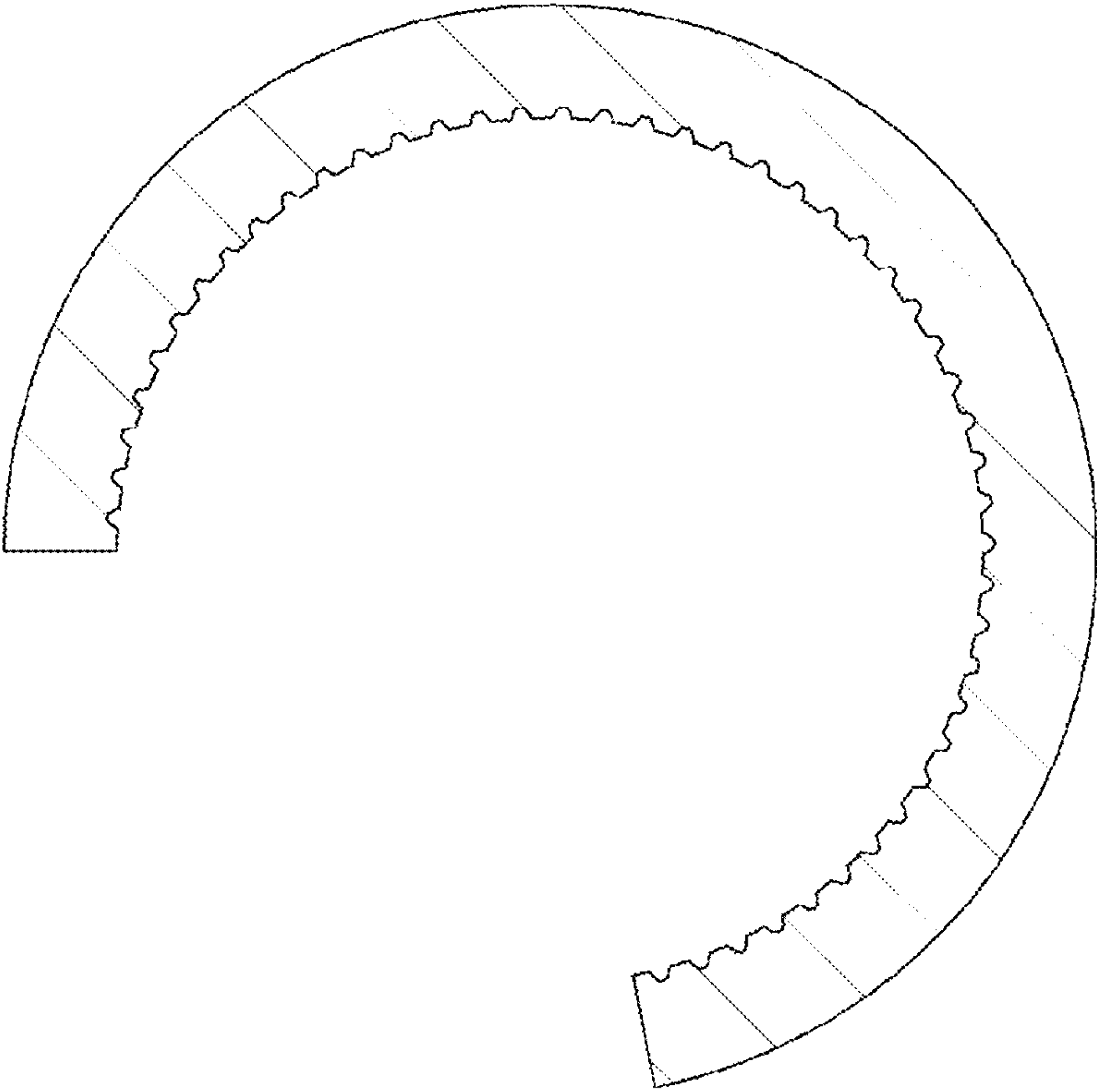

FIG. 10

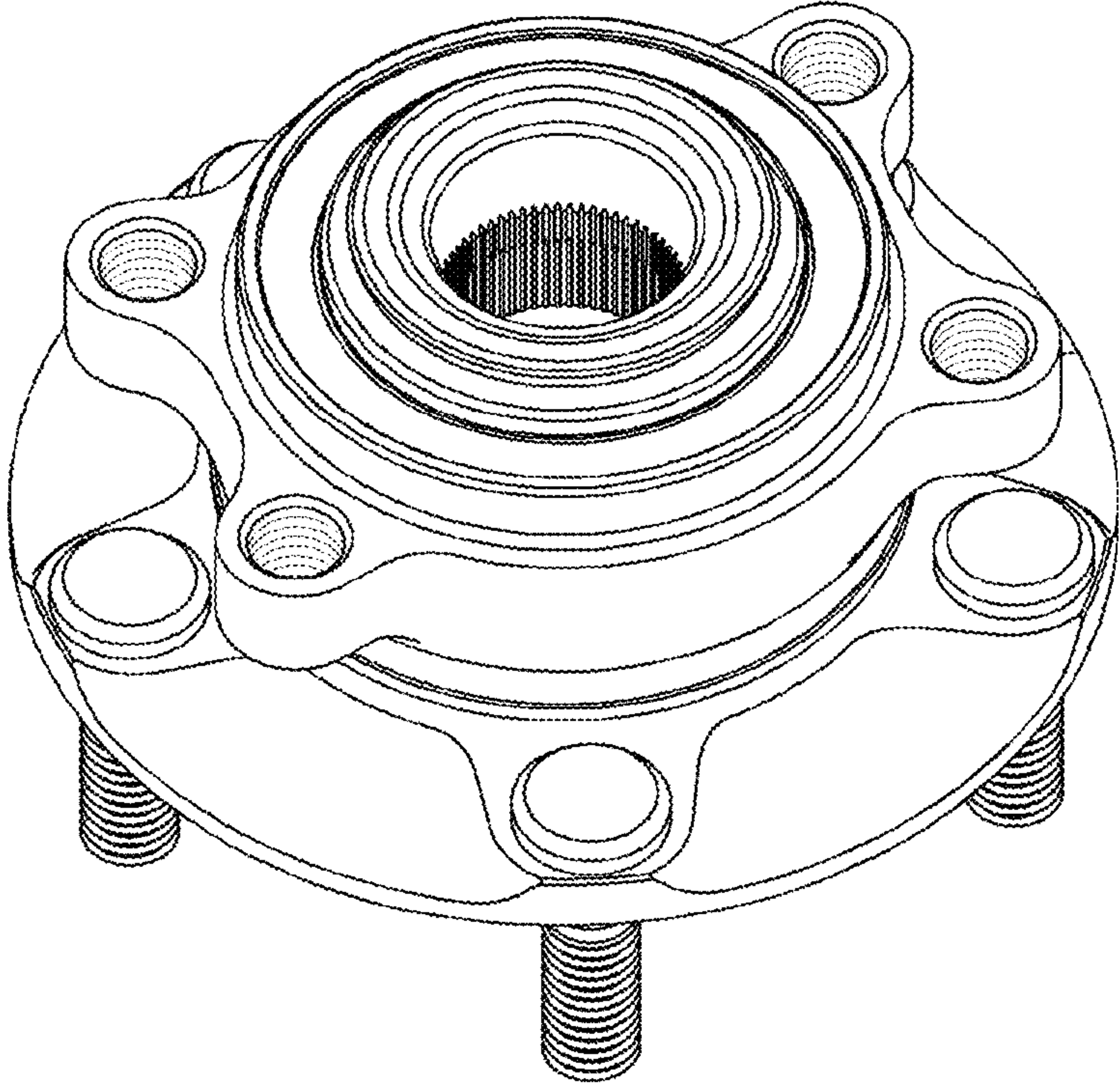

FIG. 11



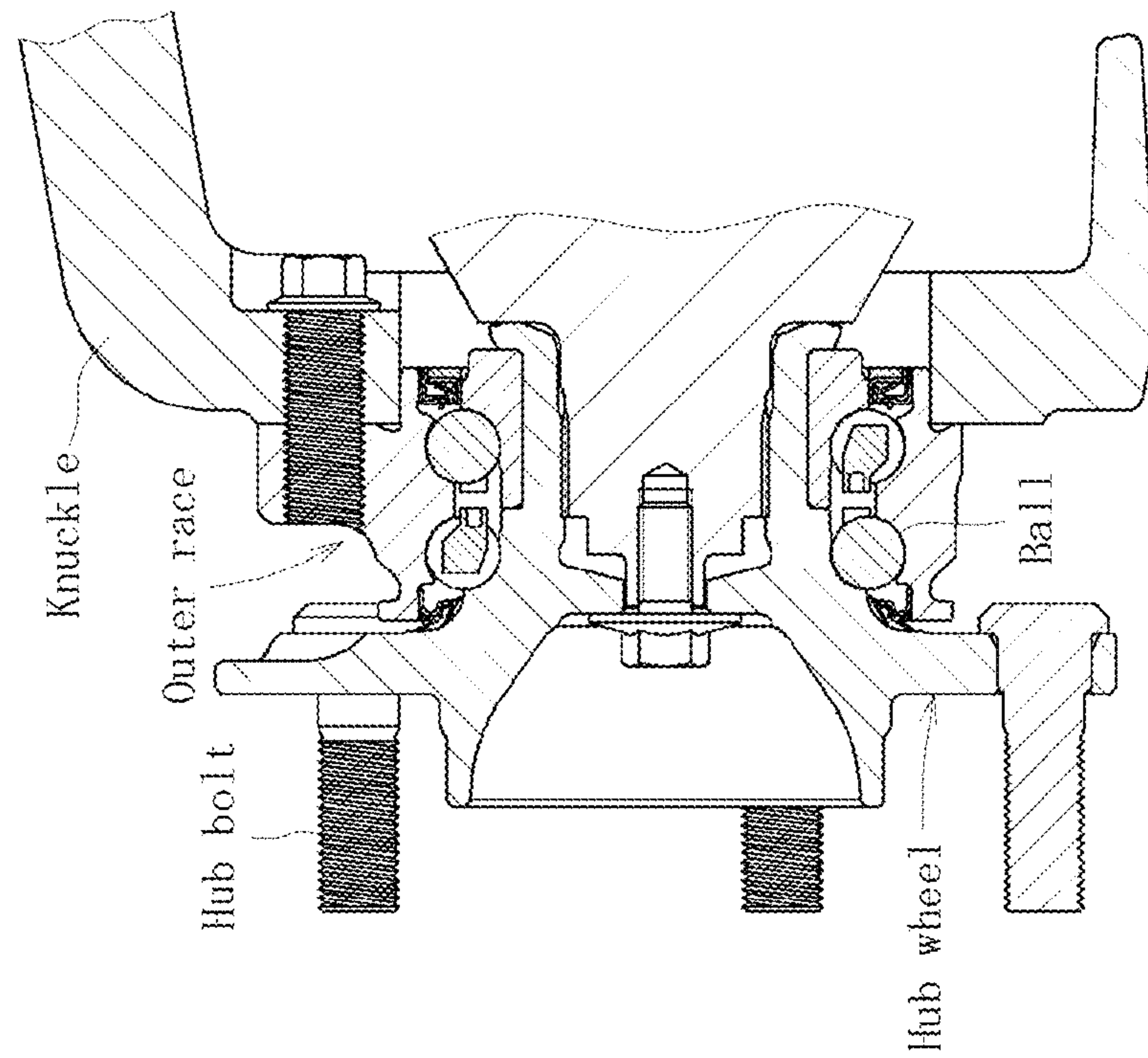

FIG. 12

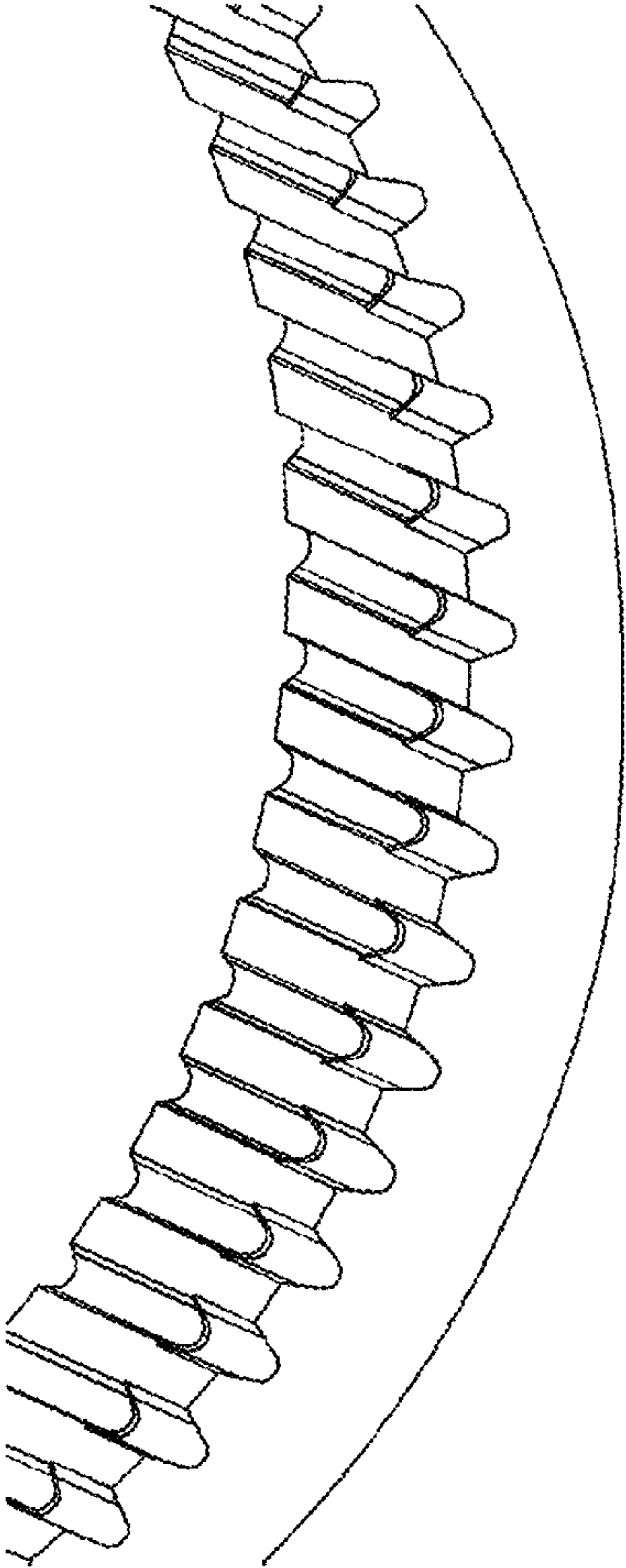

FIG. 13

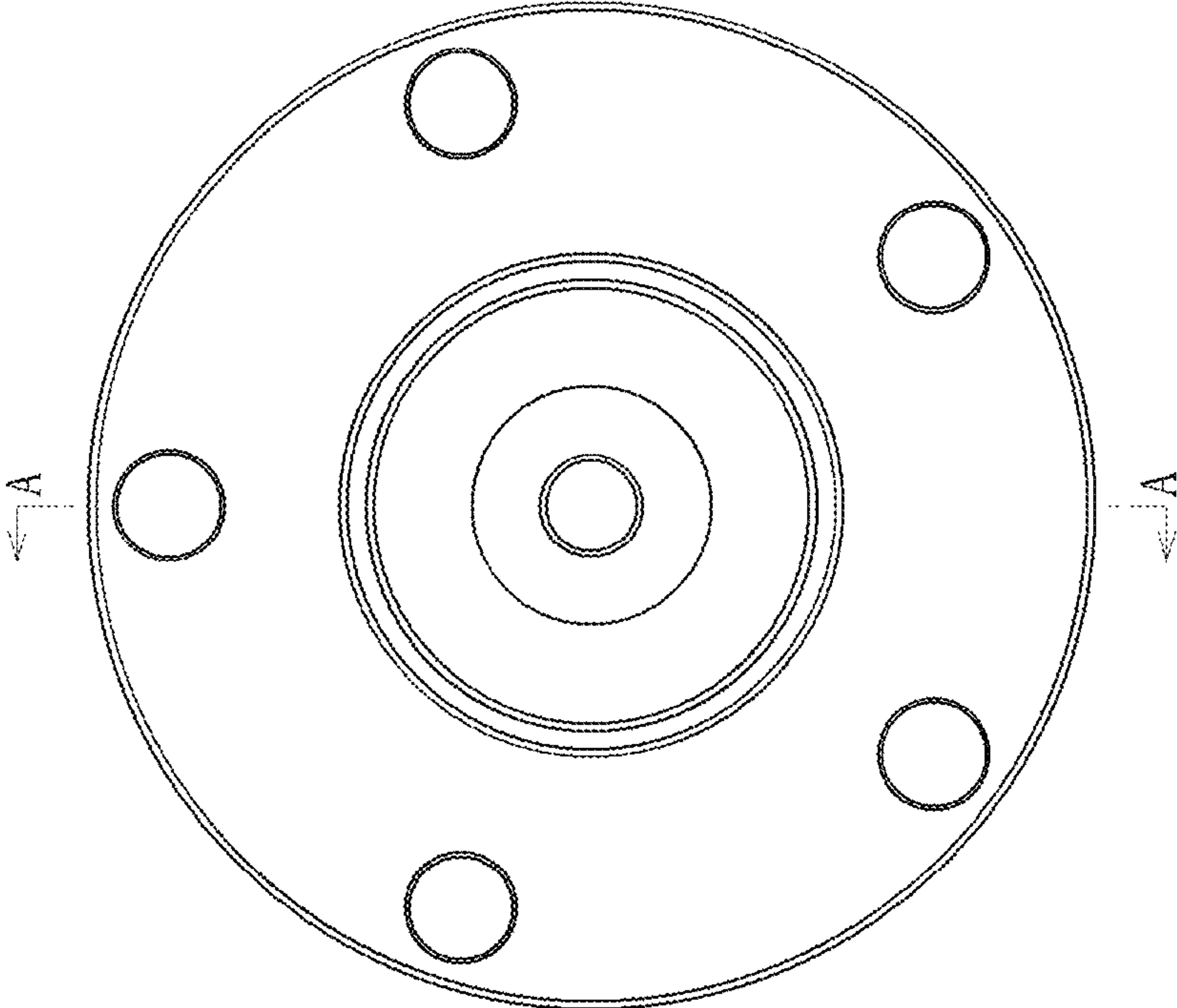

FIG. 14



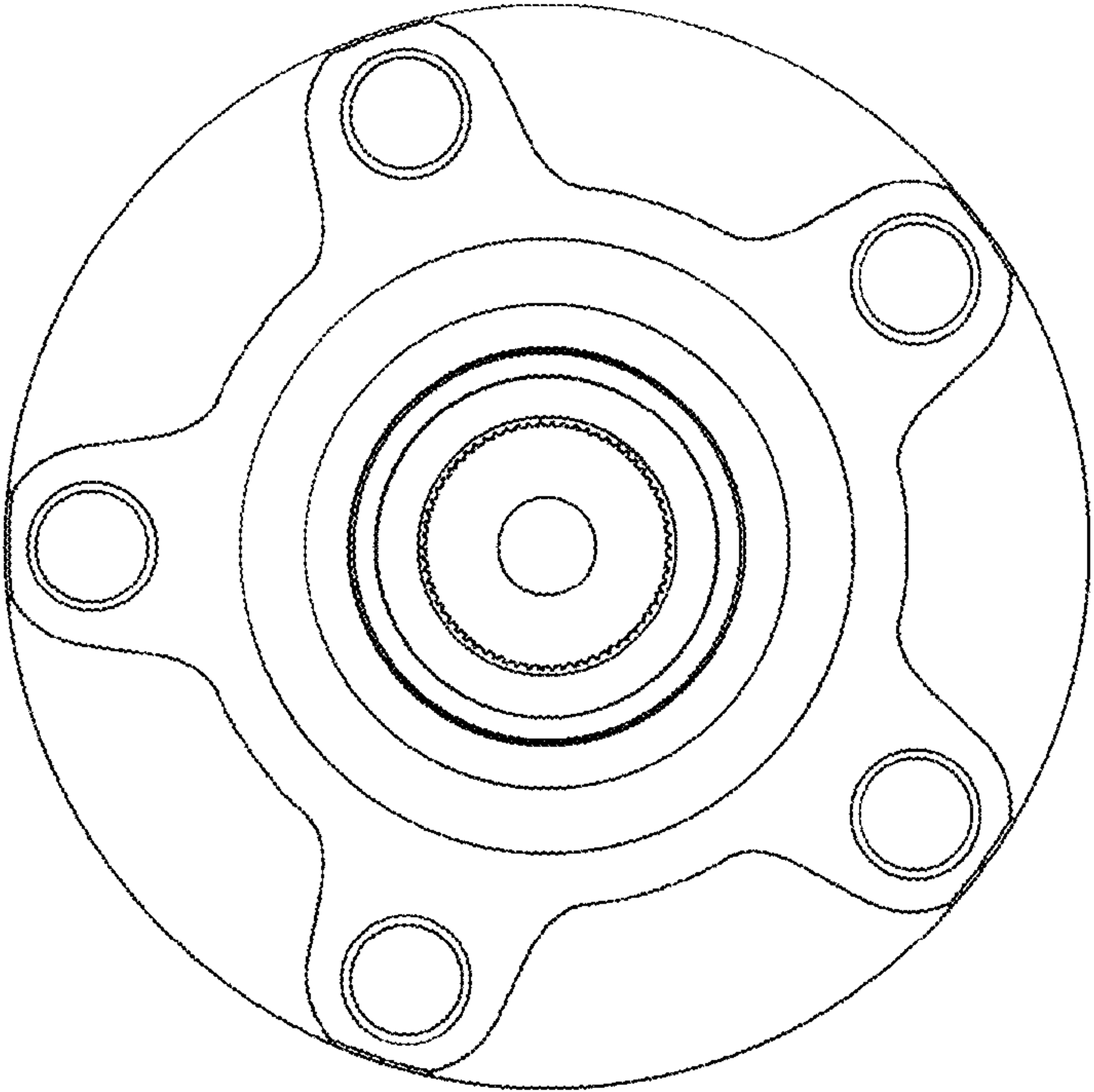
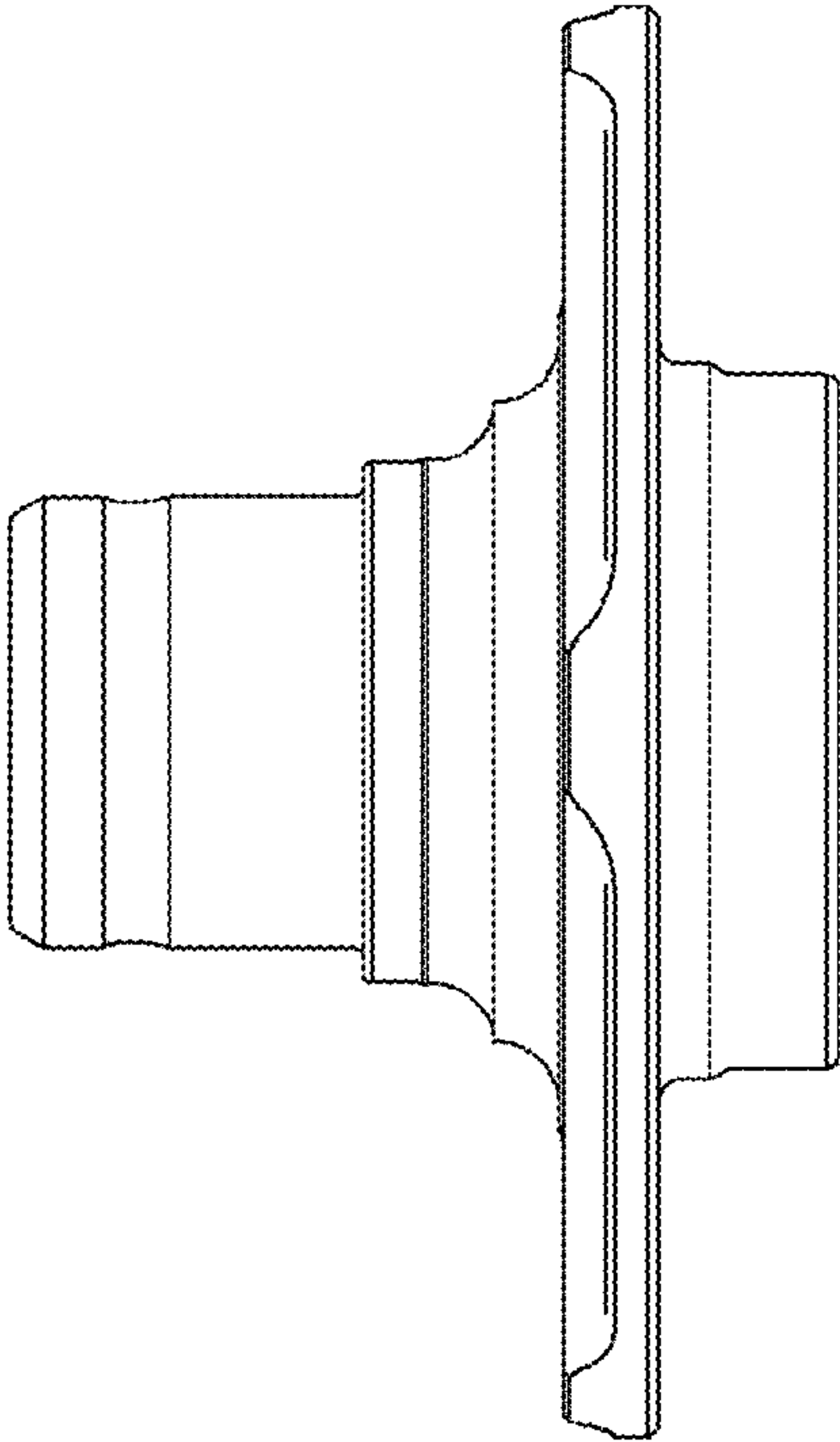

FIG. 15

FIG. 16



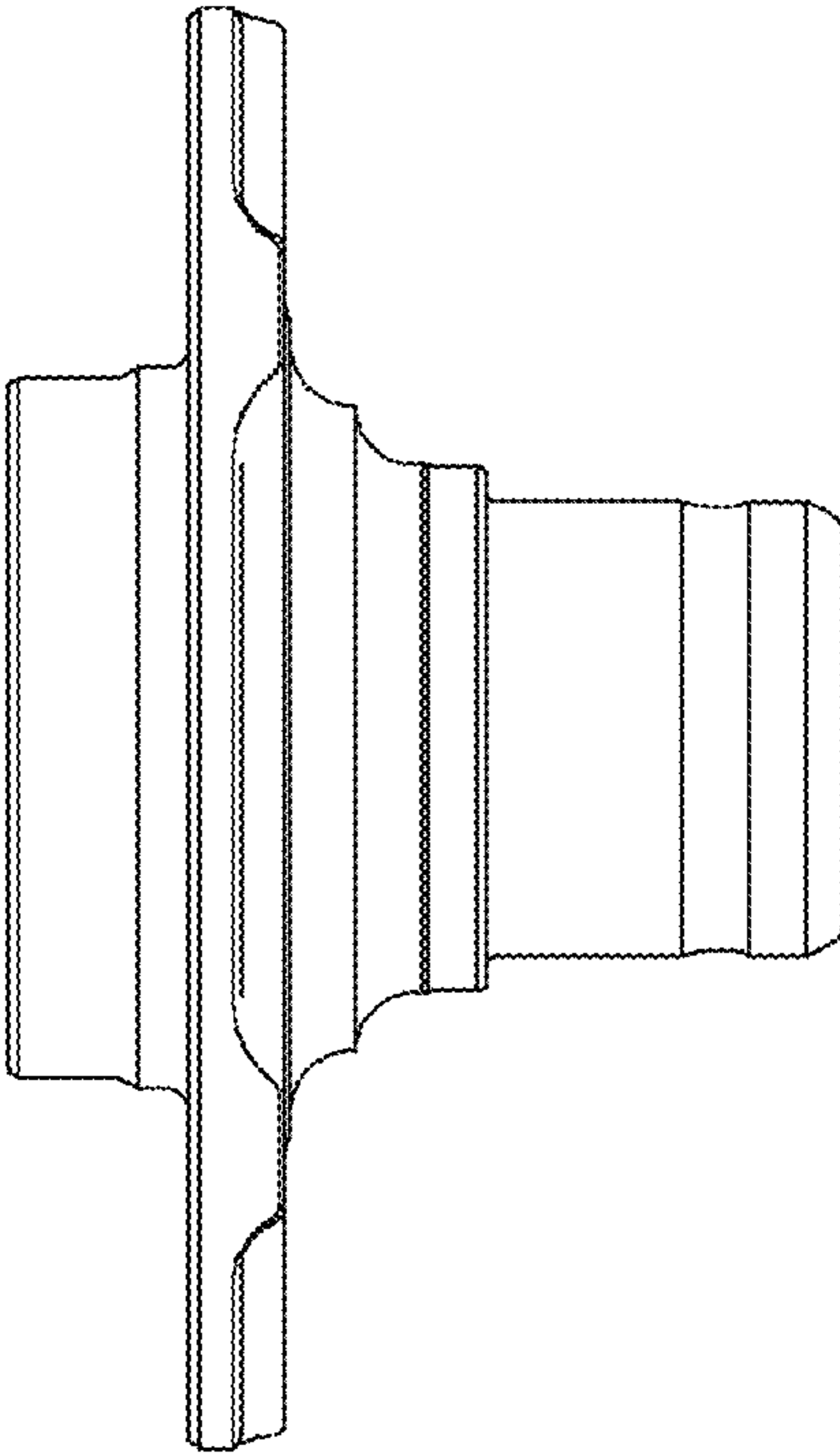

FIG. 17



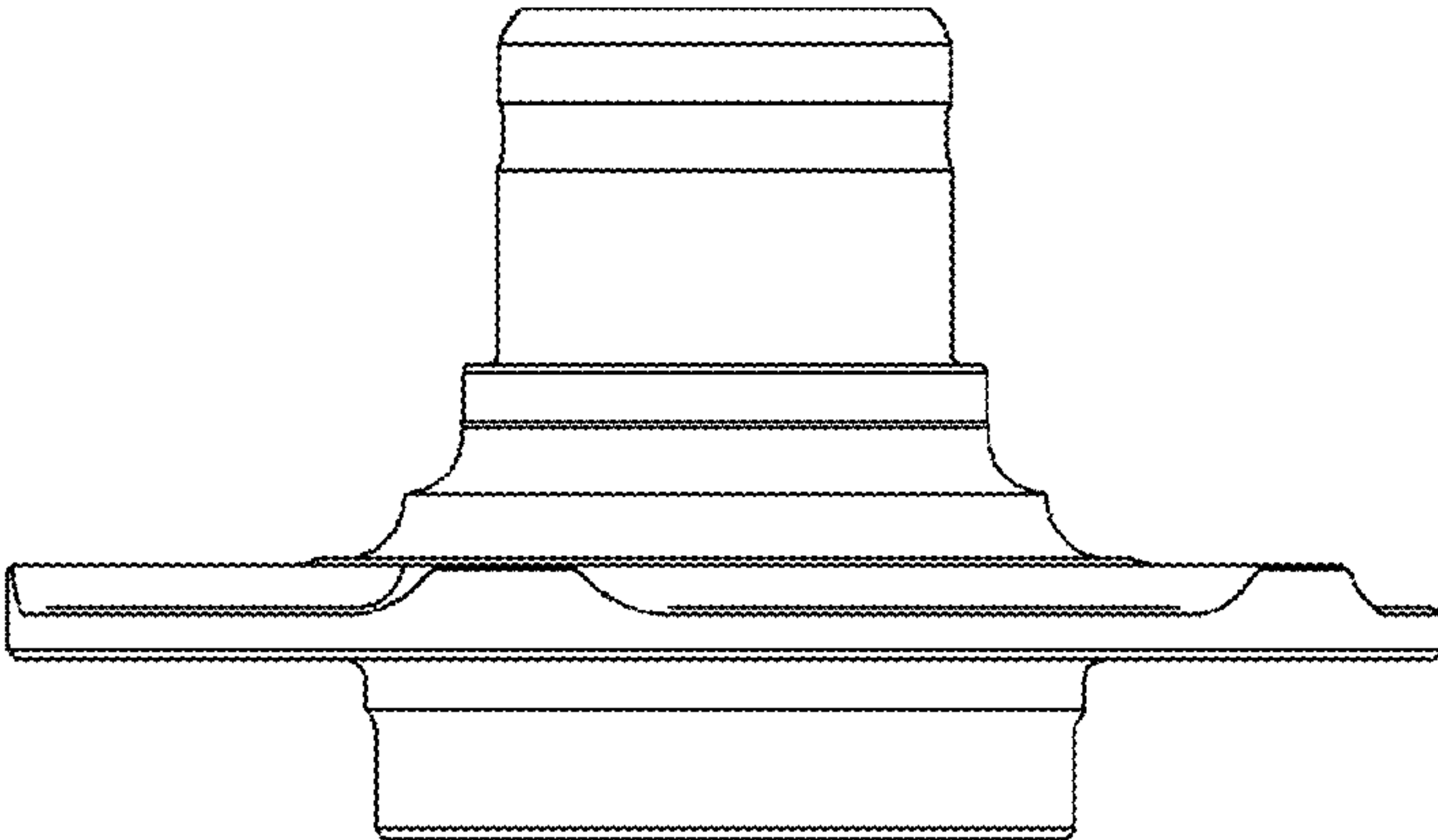

FIG. 18

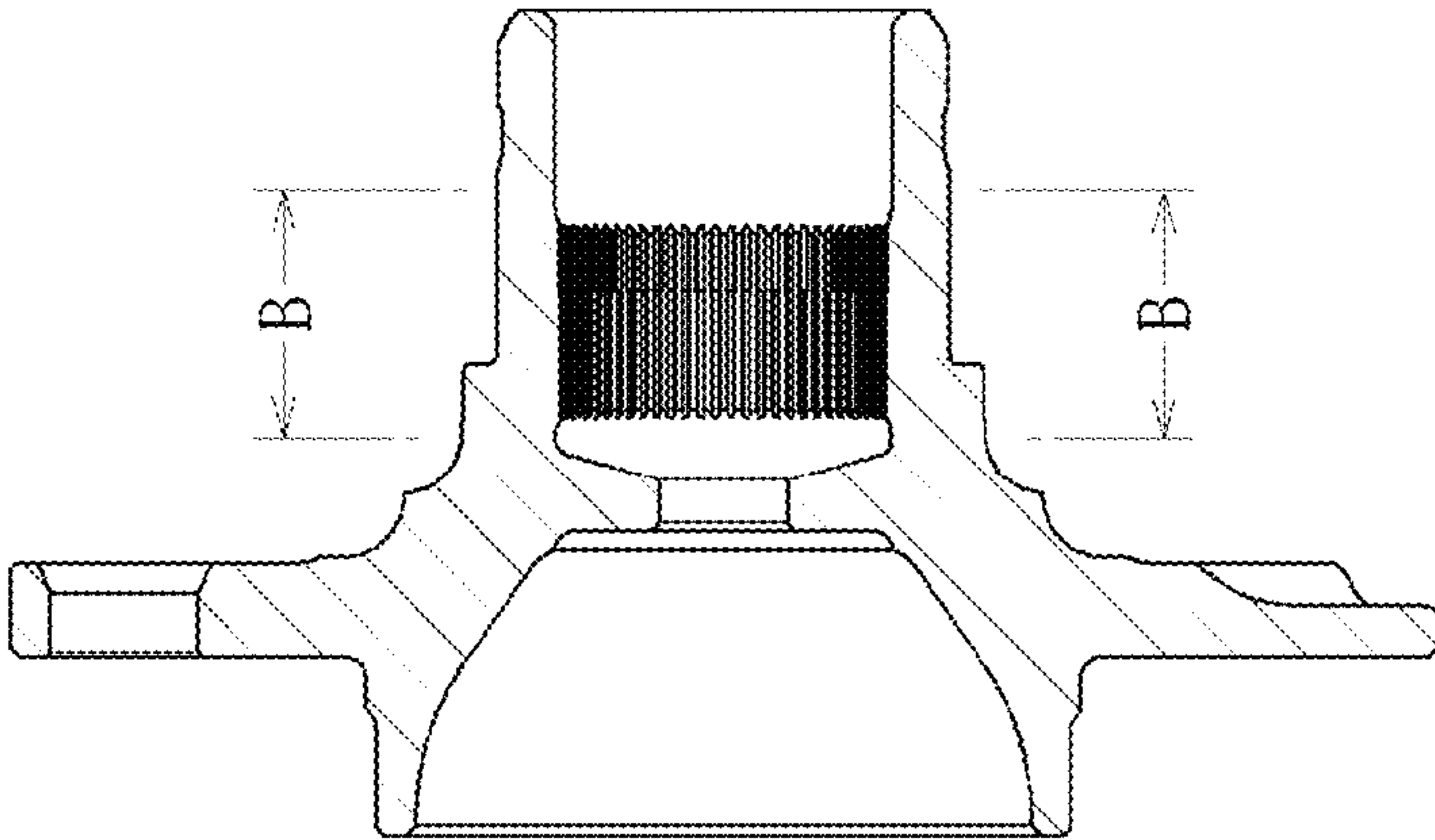

FIG. 19

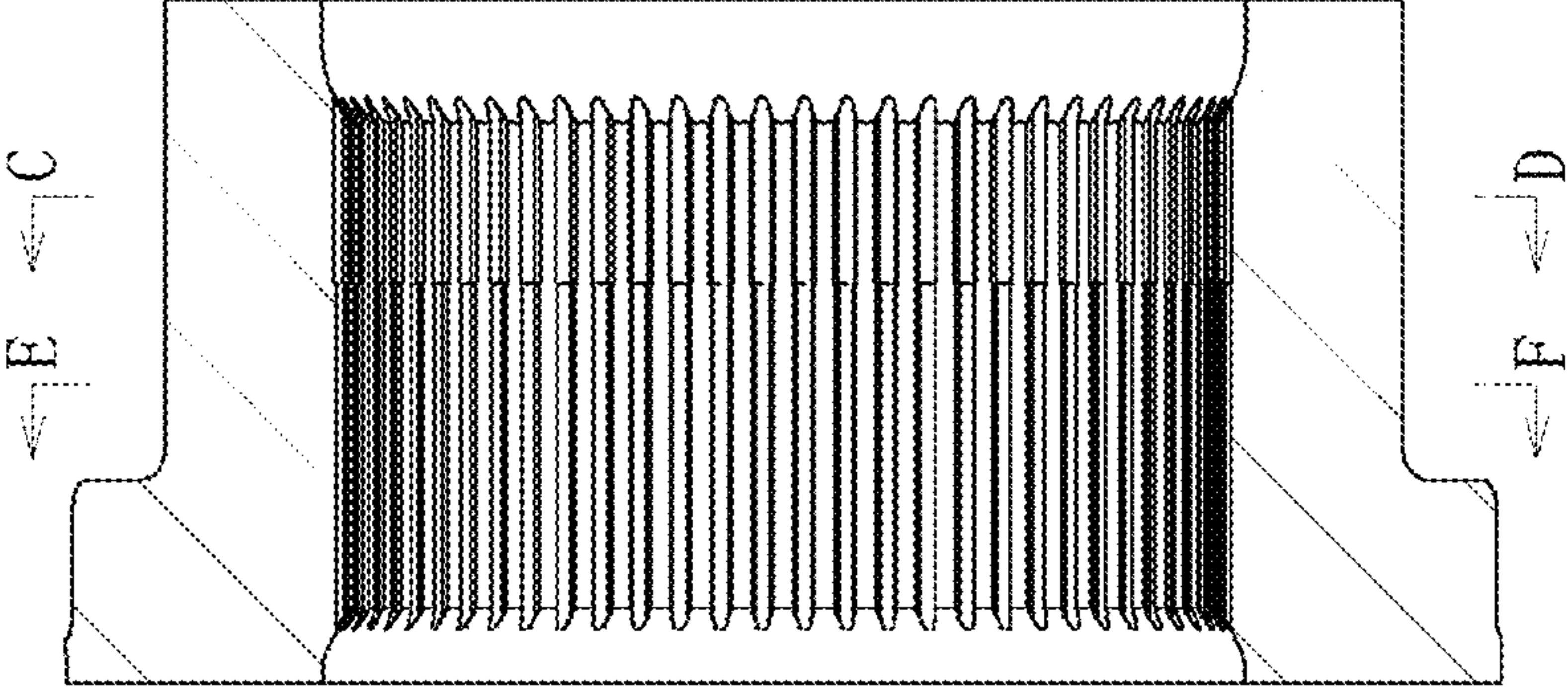

FIG. 20

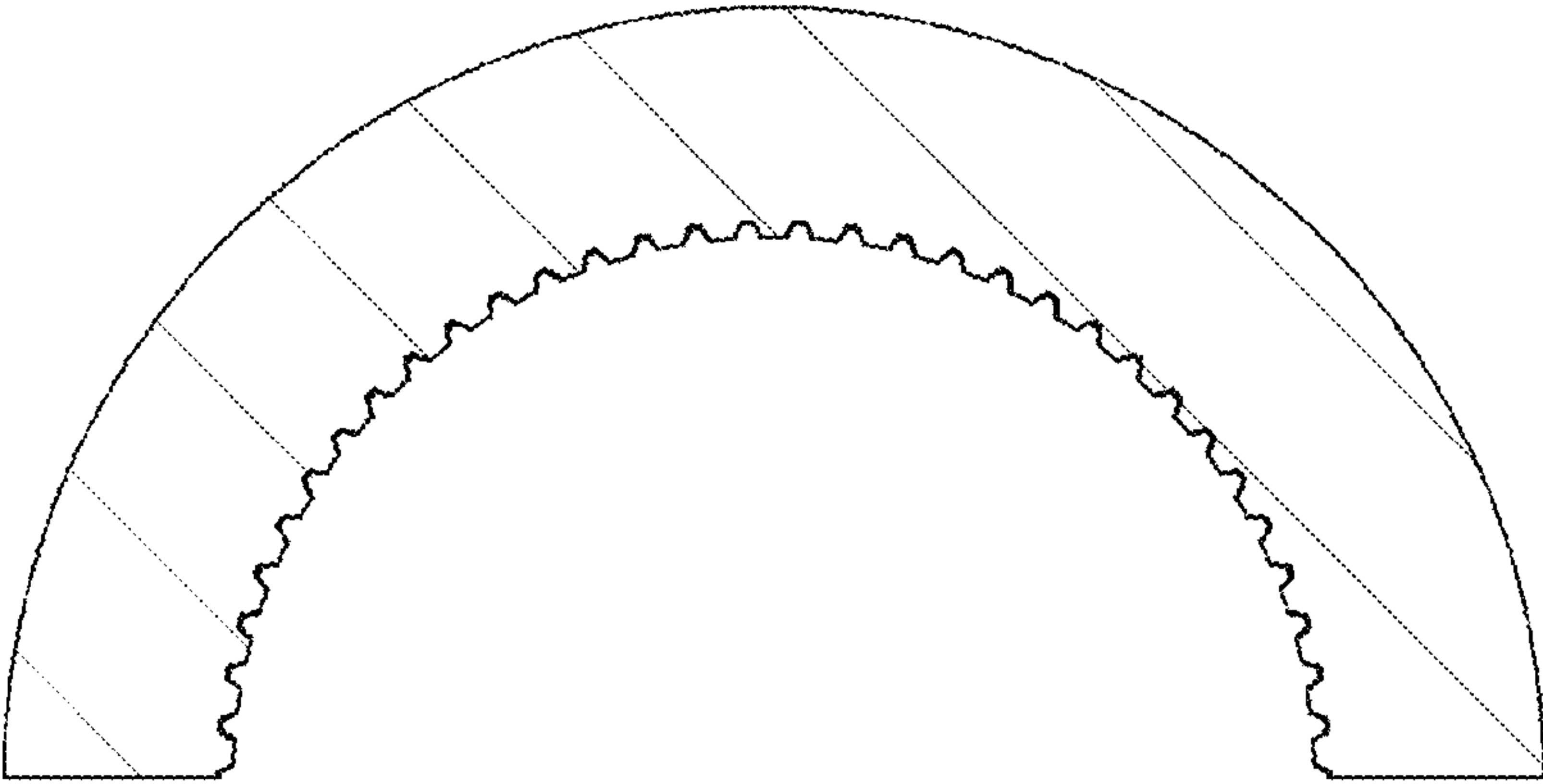

FIG. 21



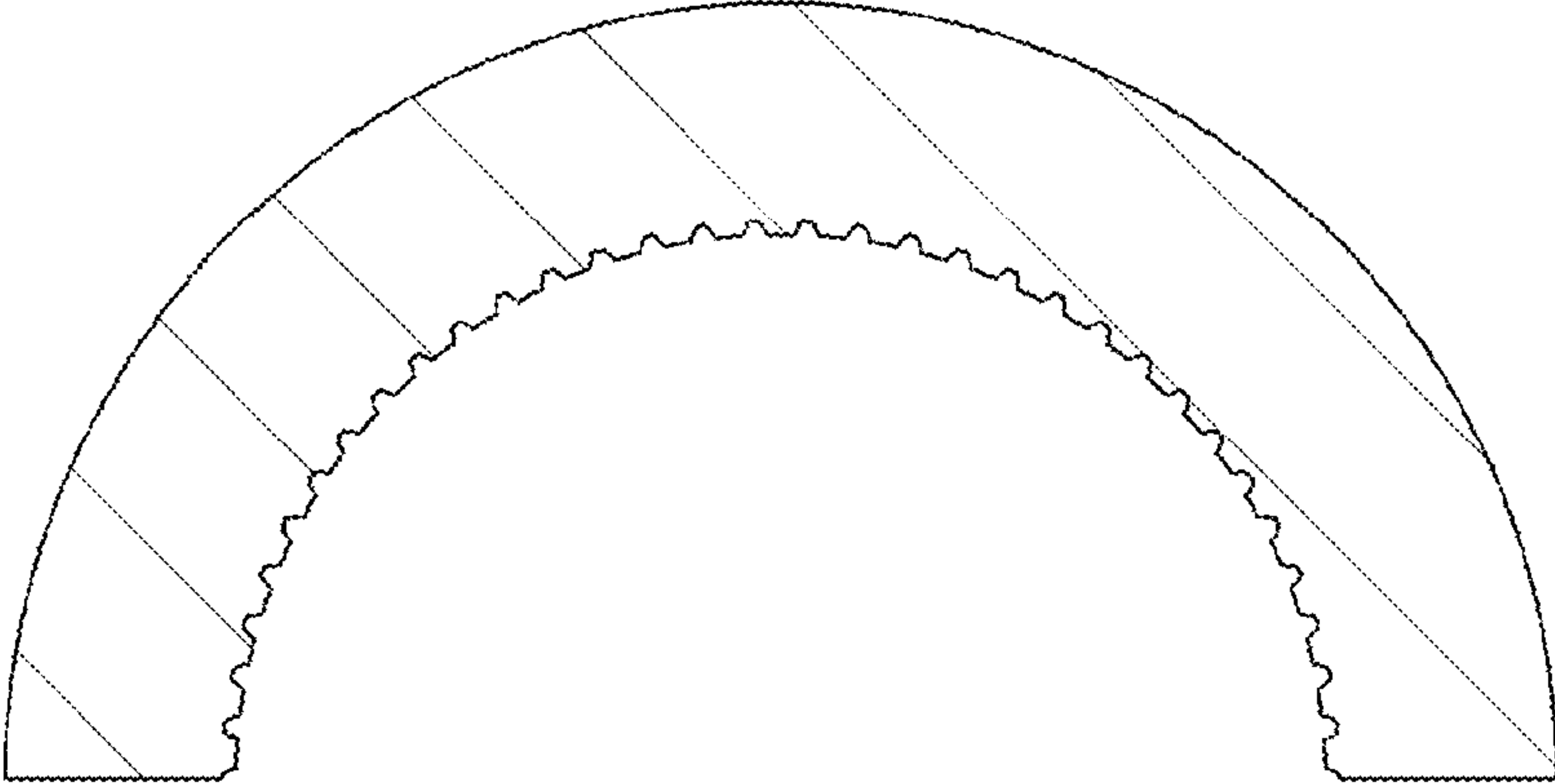

FIG. 22

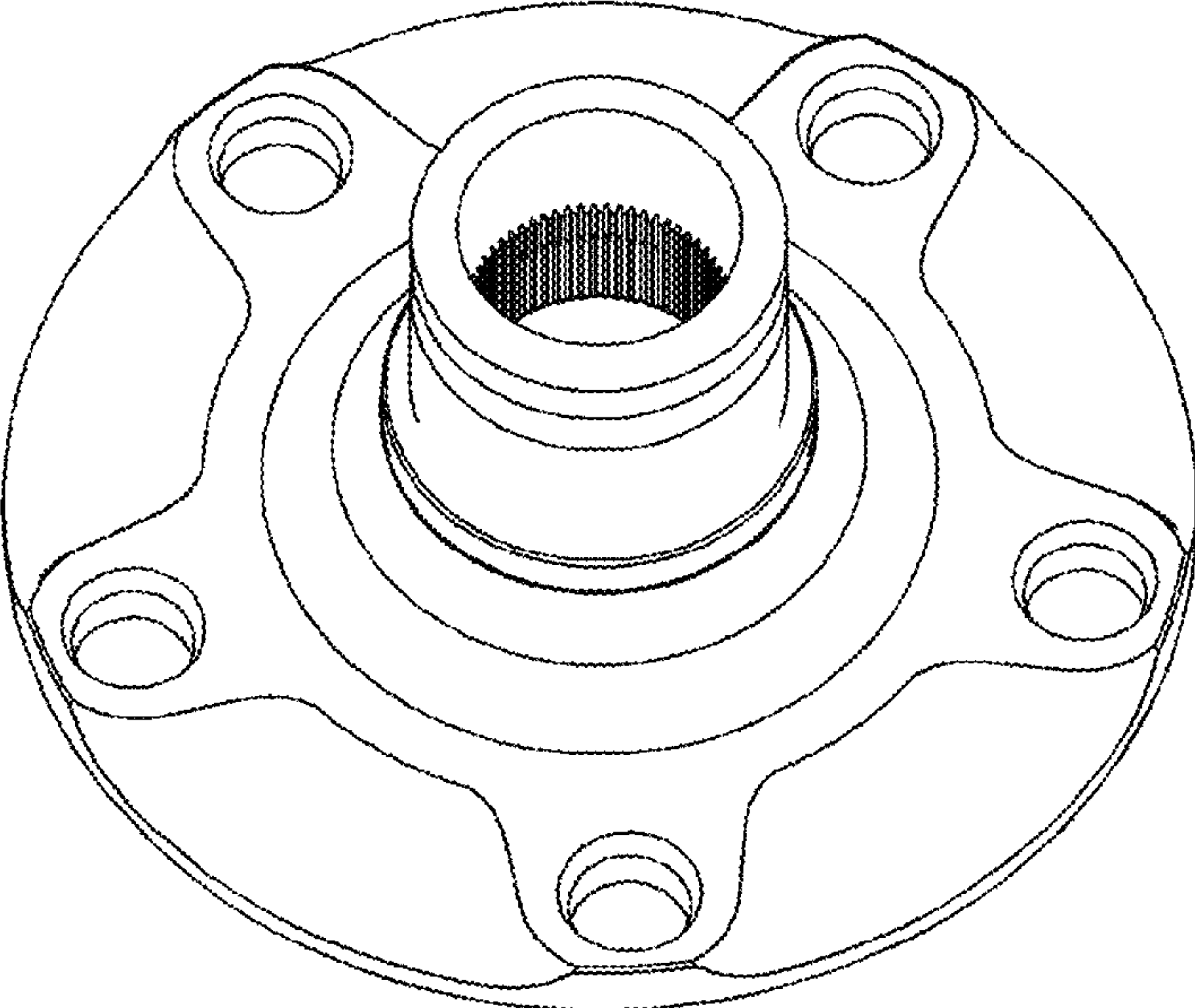

FIG. 23

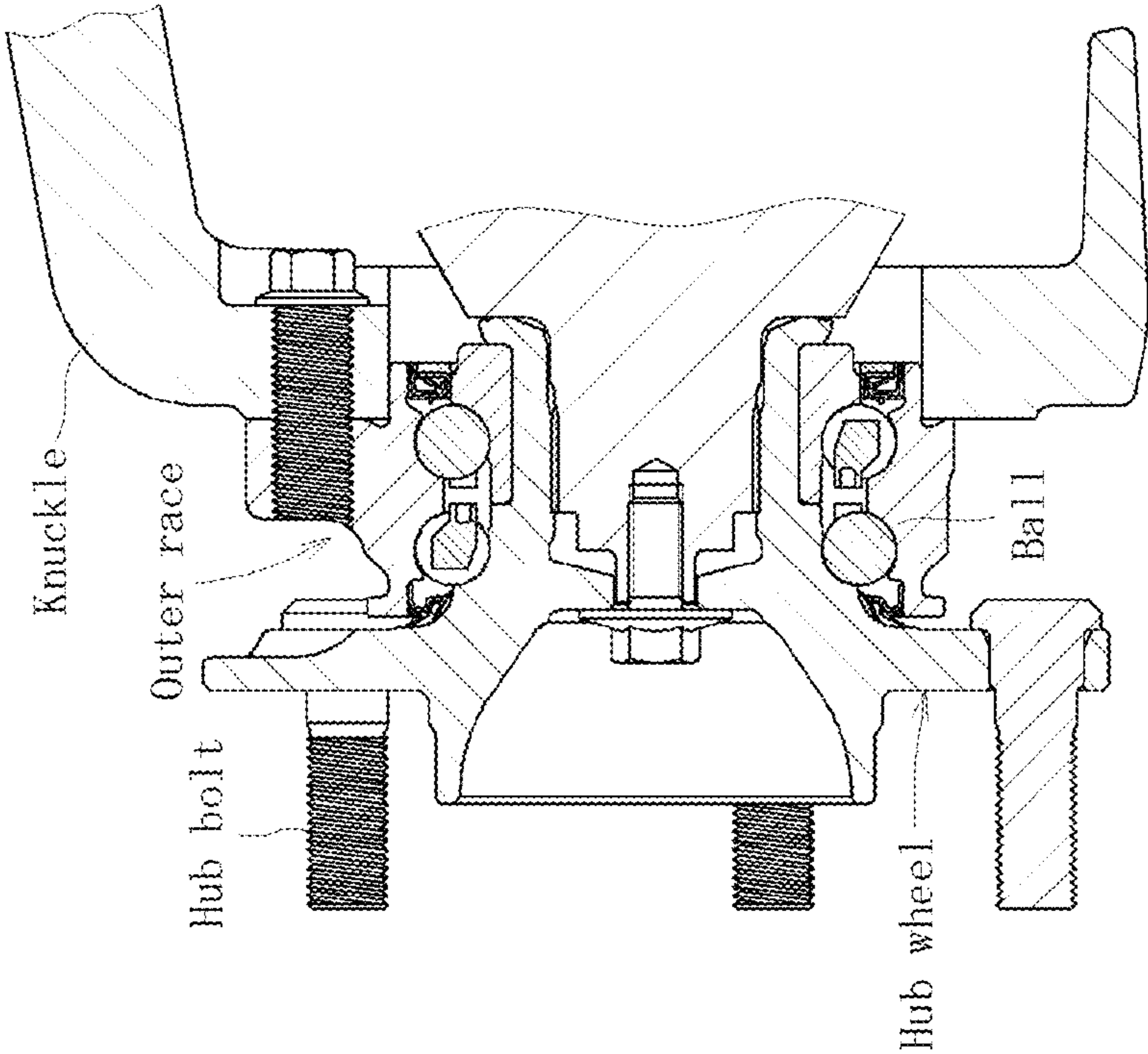

FIG. 24

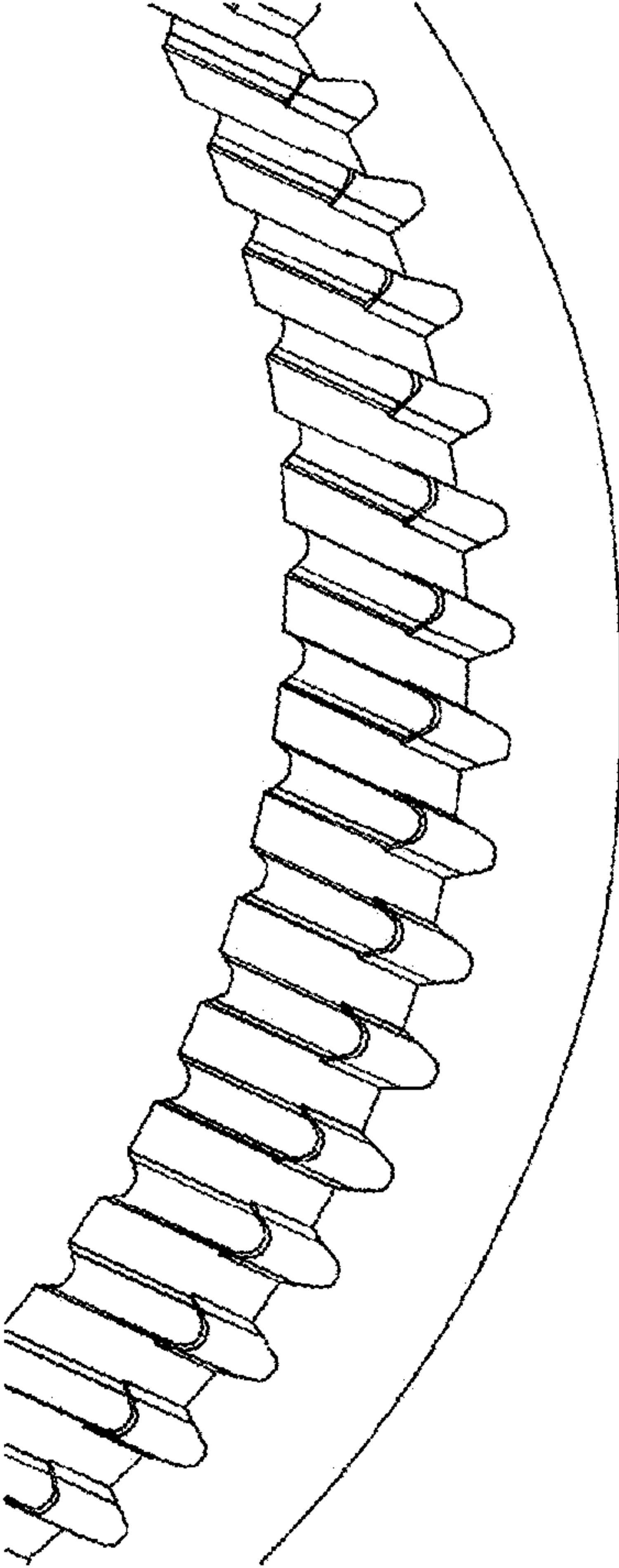

FIG. 25



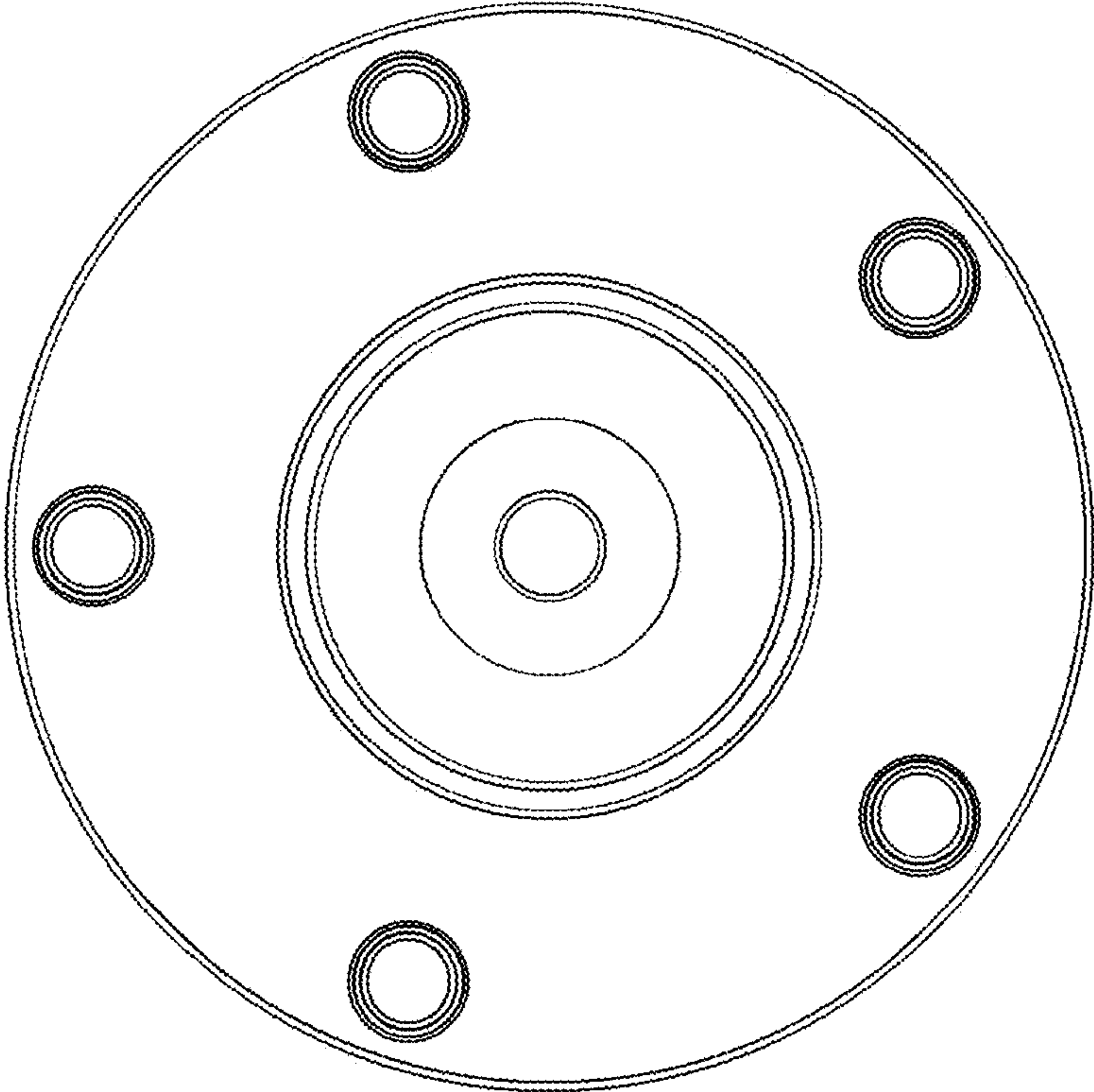

FIG. 26

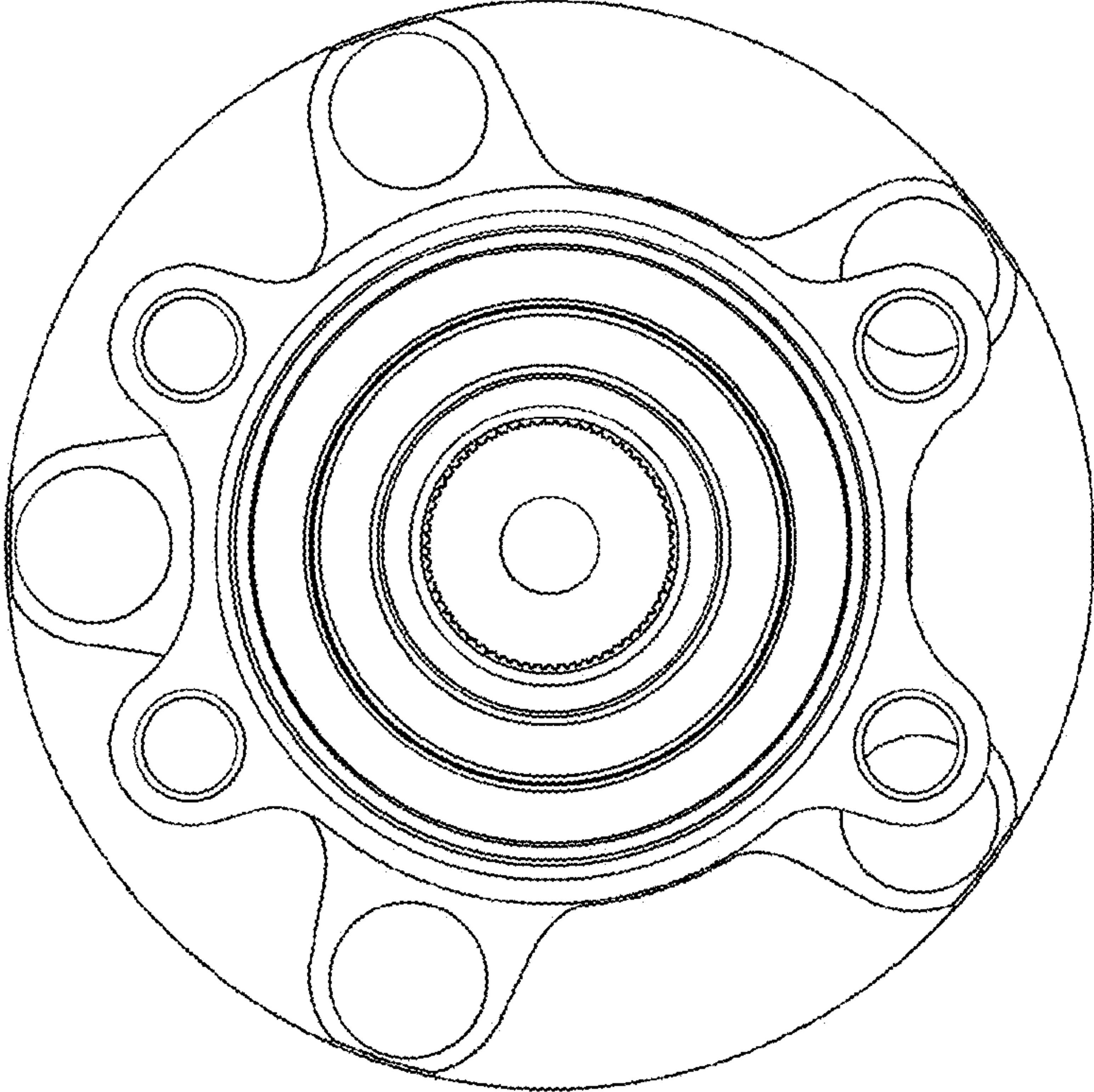

FIG. 27

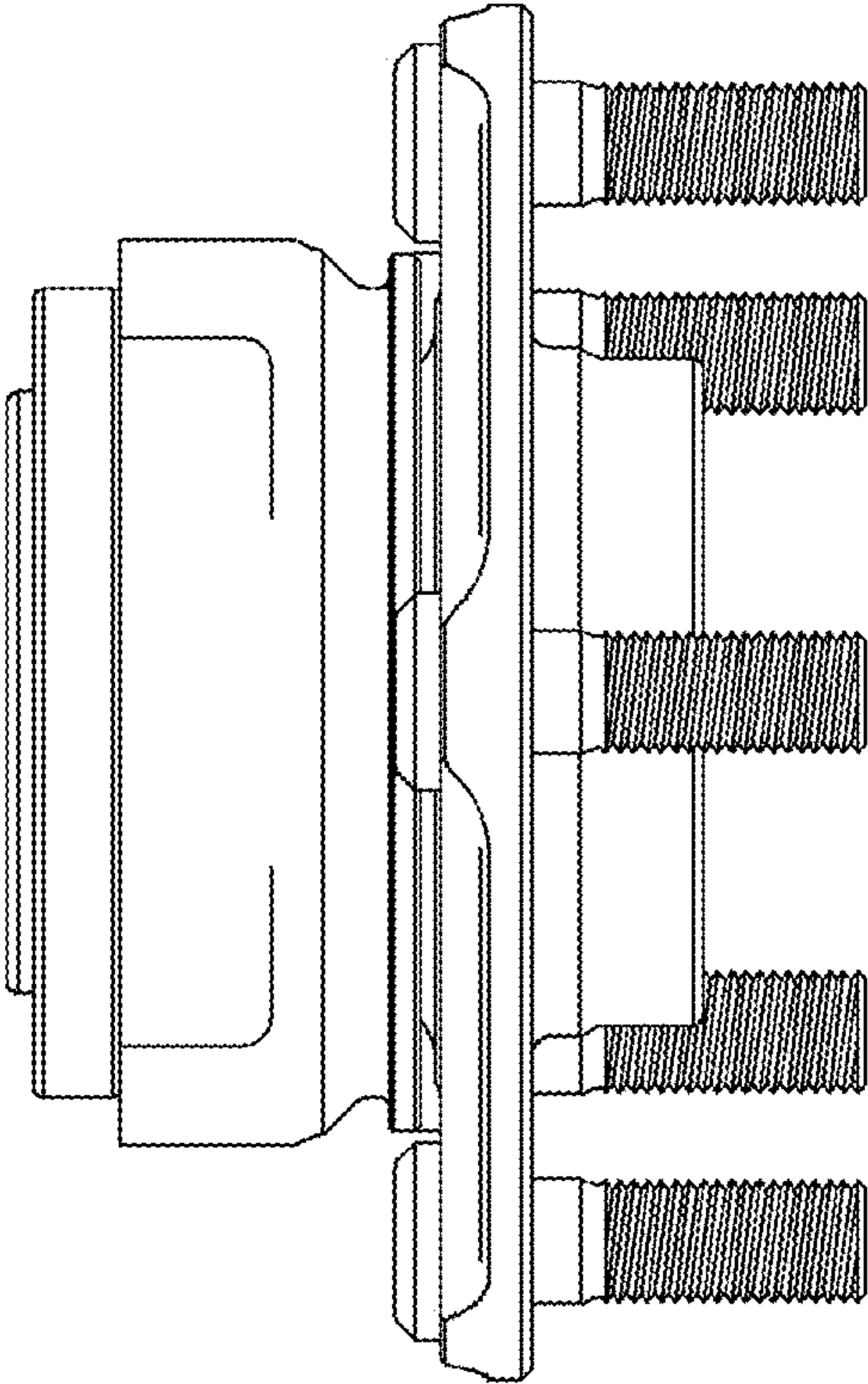
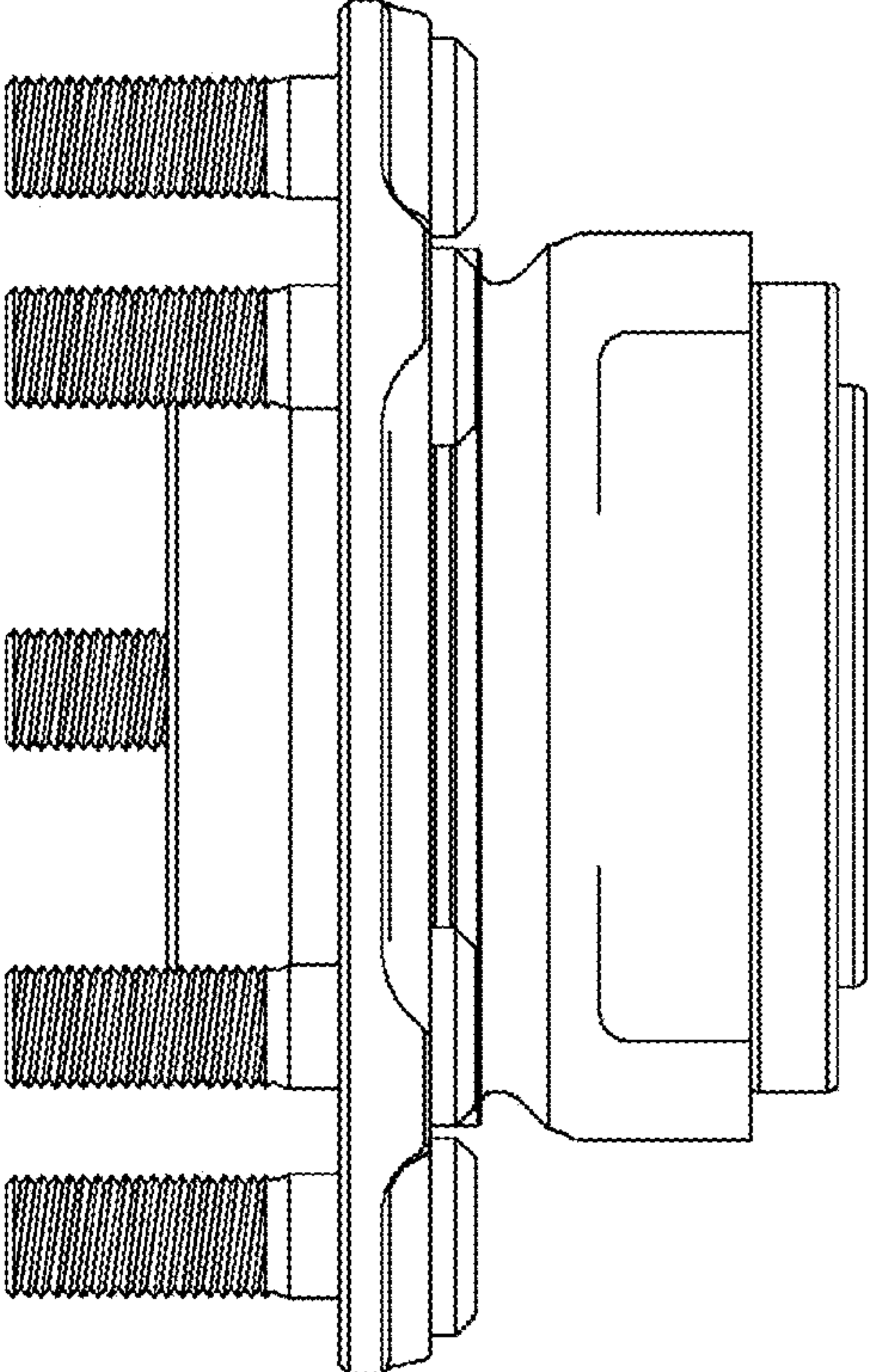

FIG. 28

FIG. 29





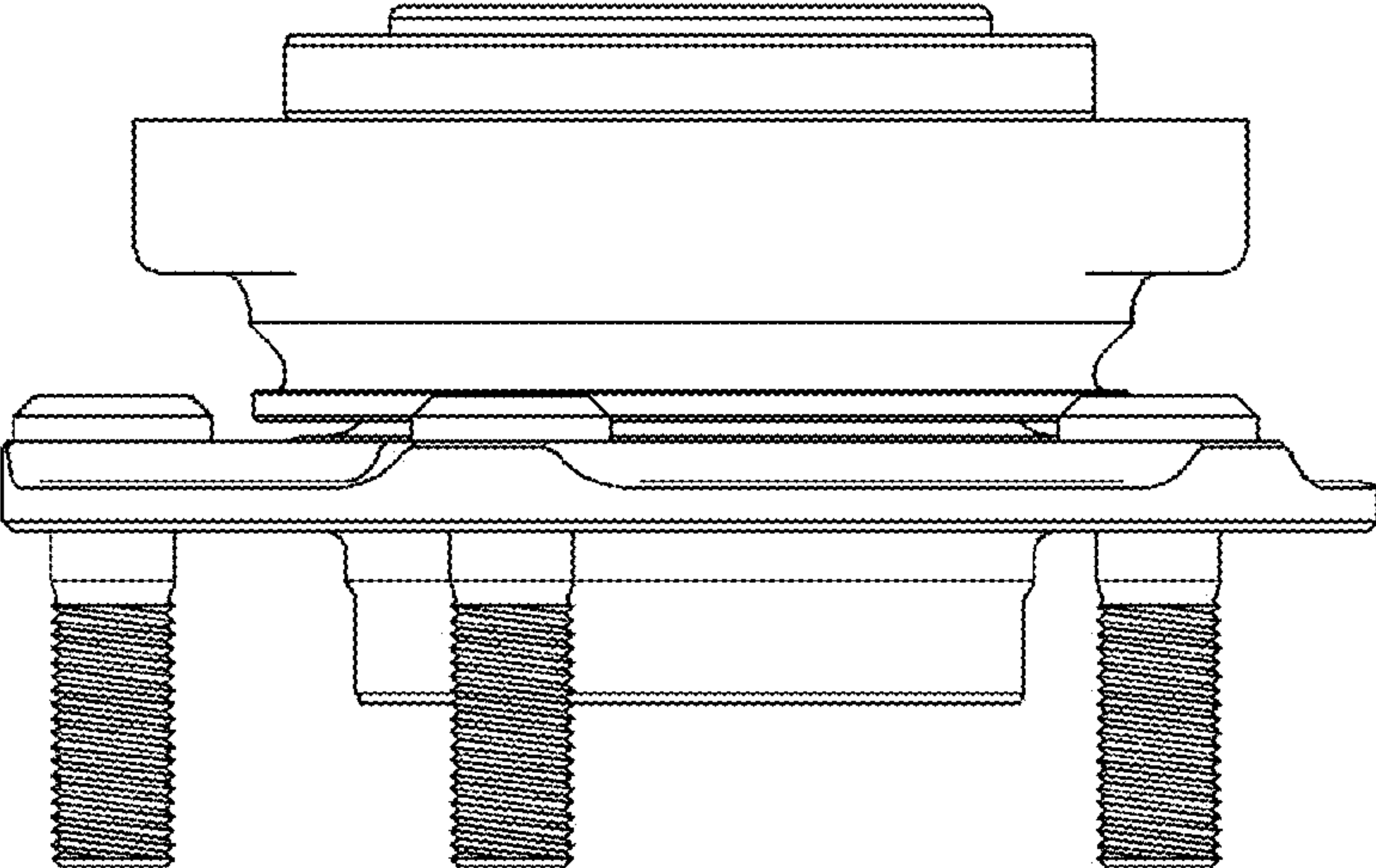

FIG. 30

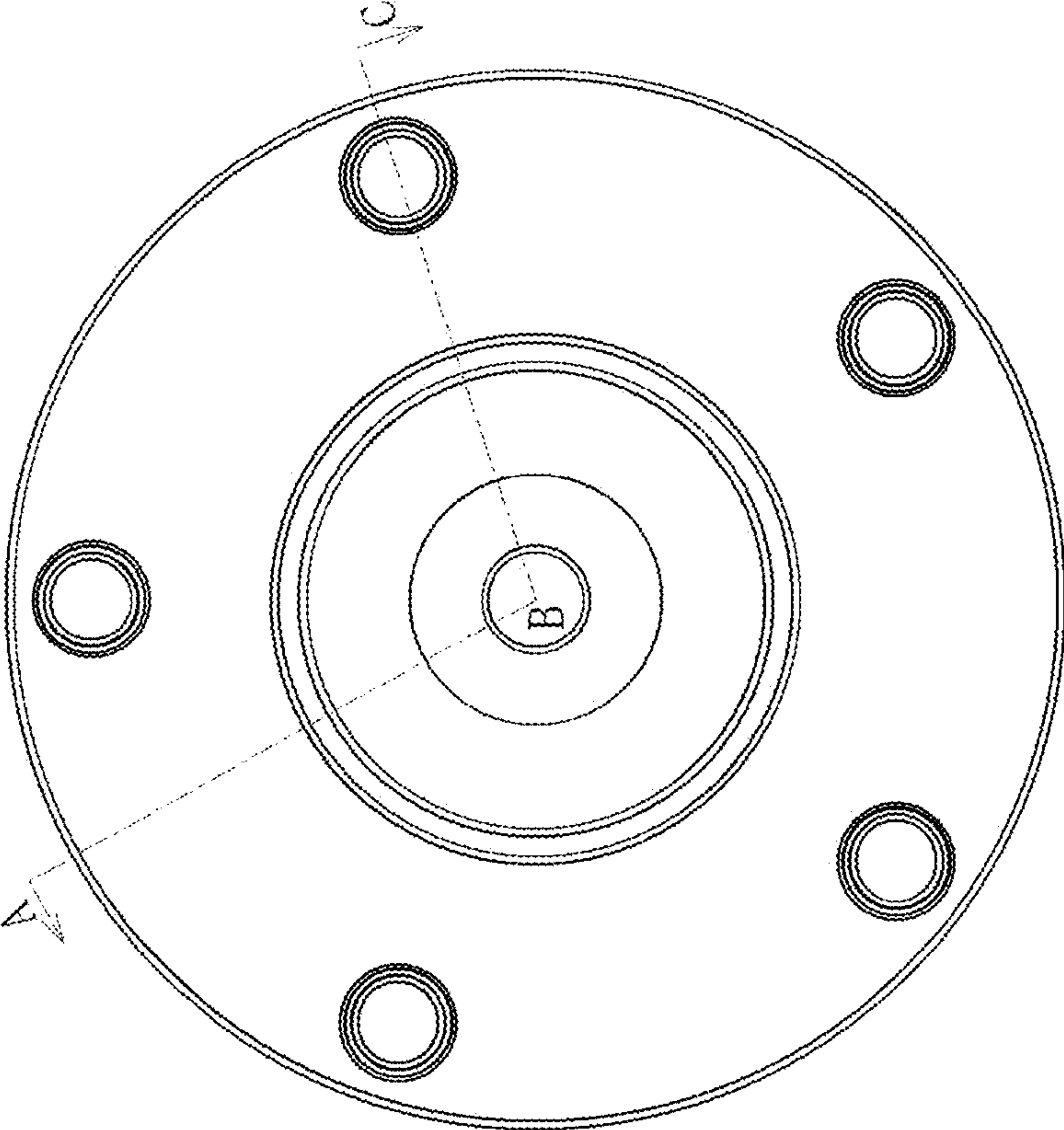

FIG. 31

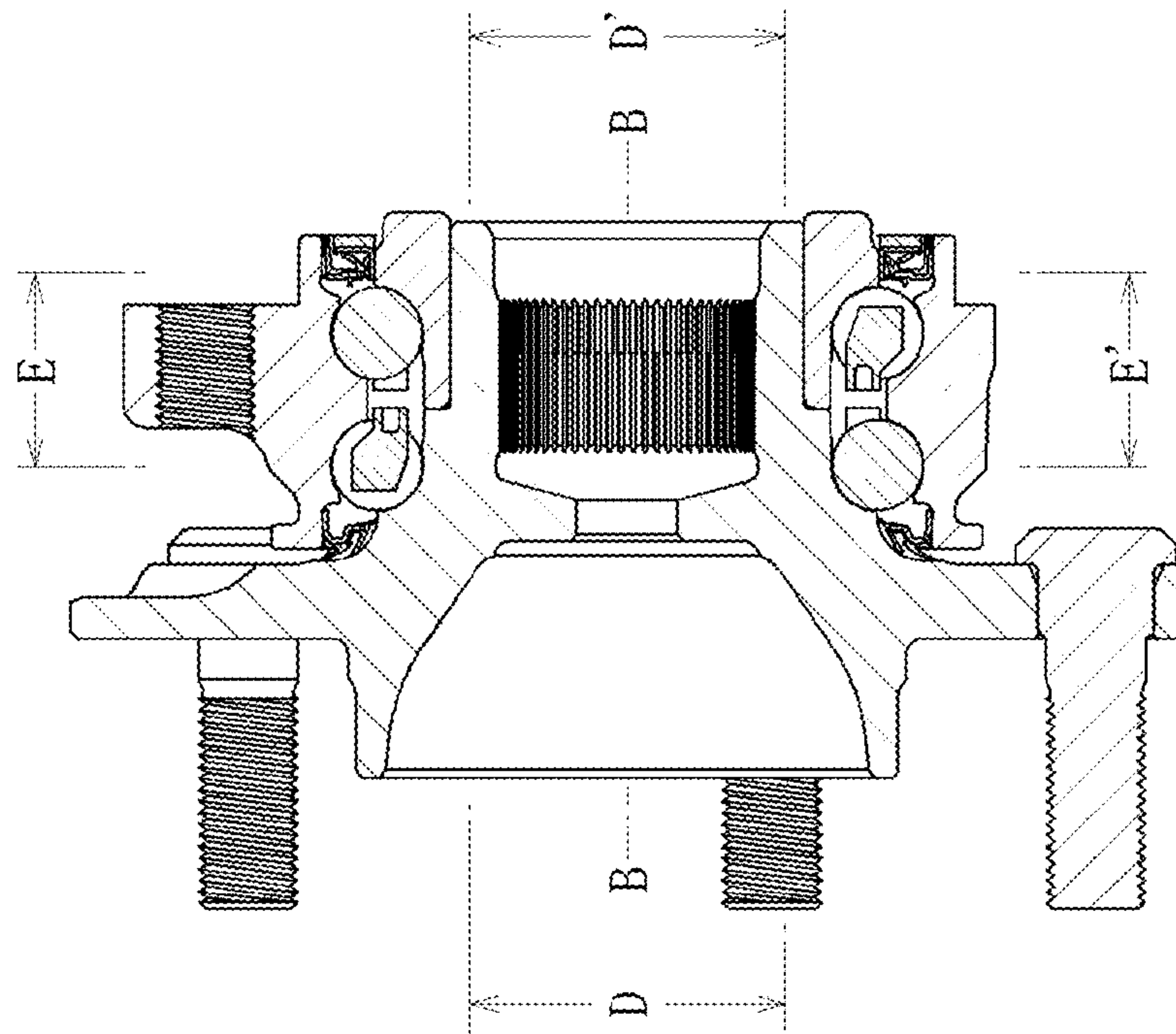
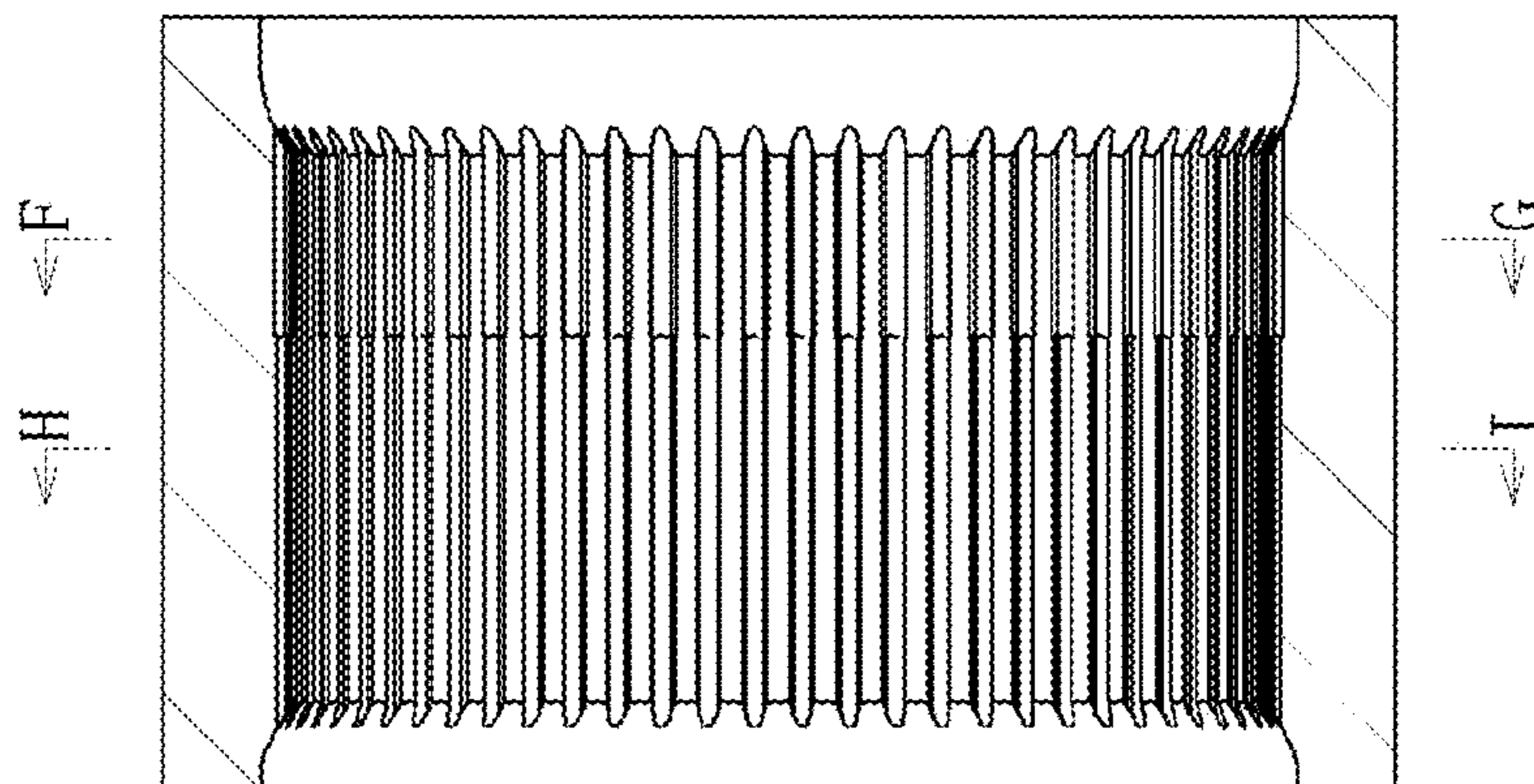

FIG. 32

FIG. 33



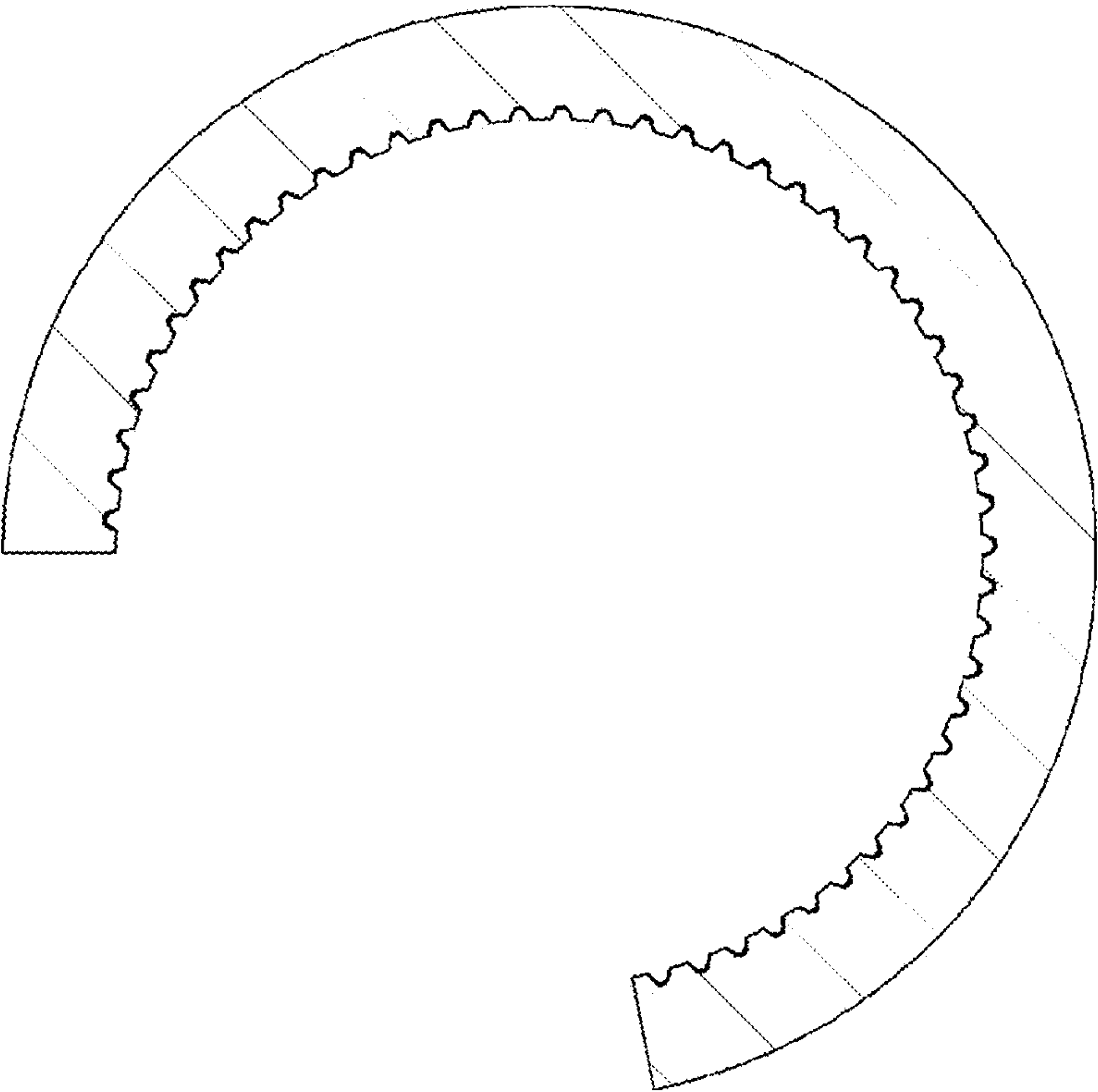

FIG. 34



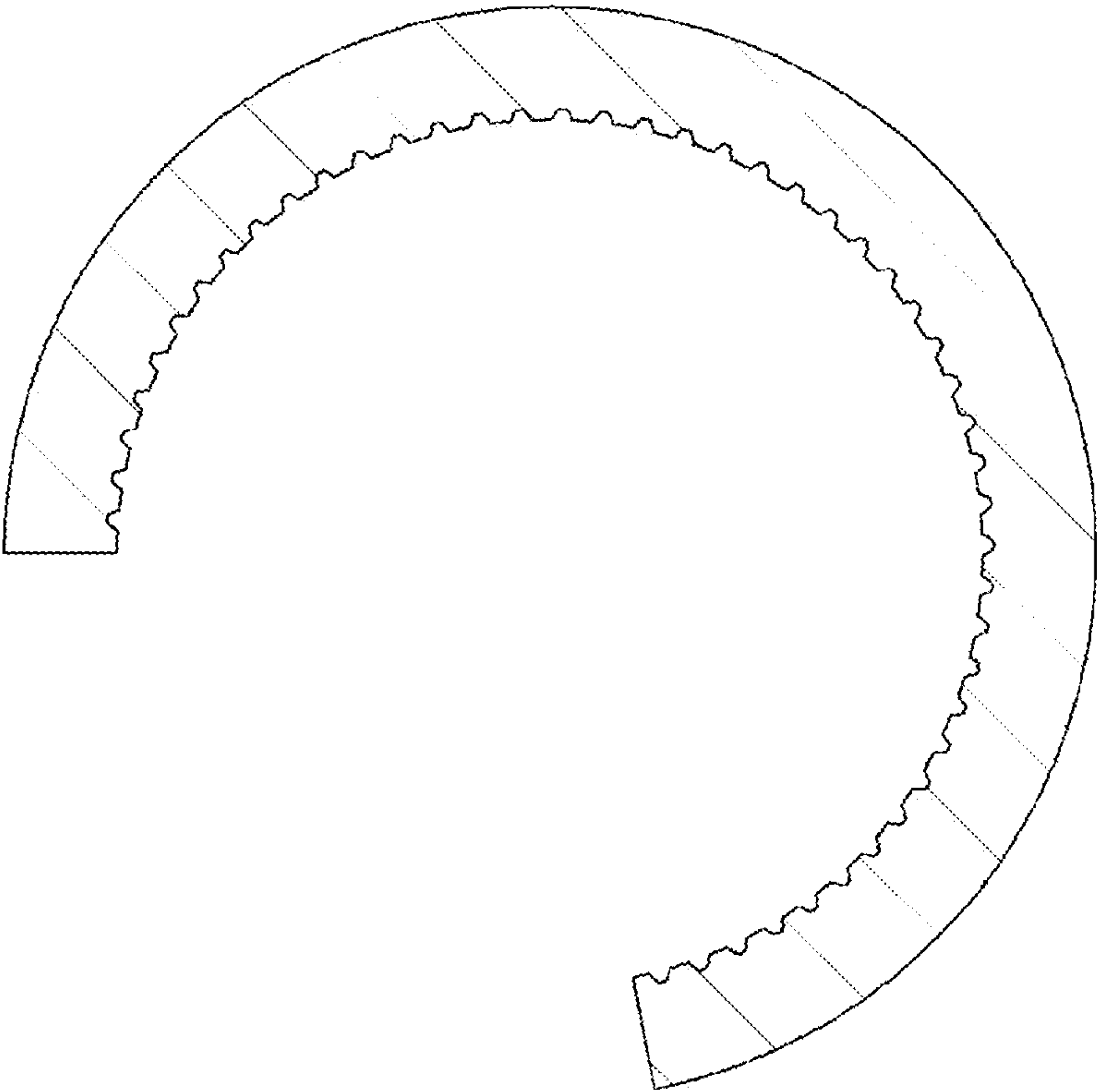

FIG. 35

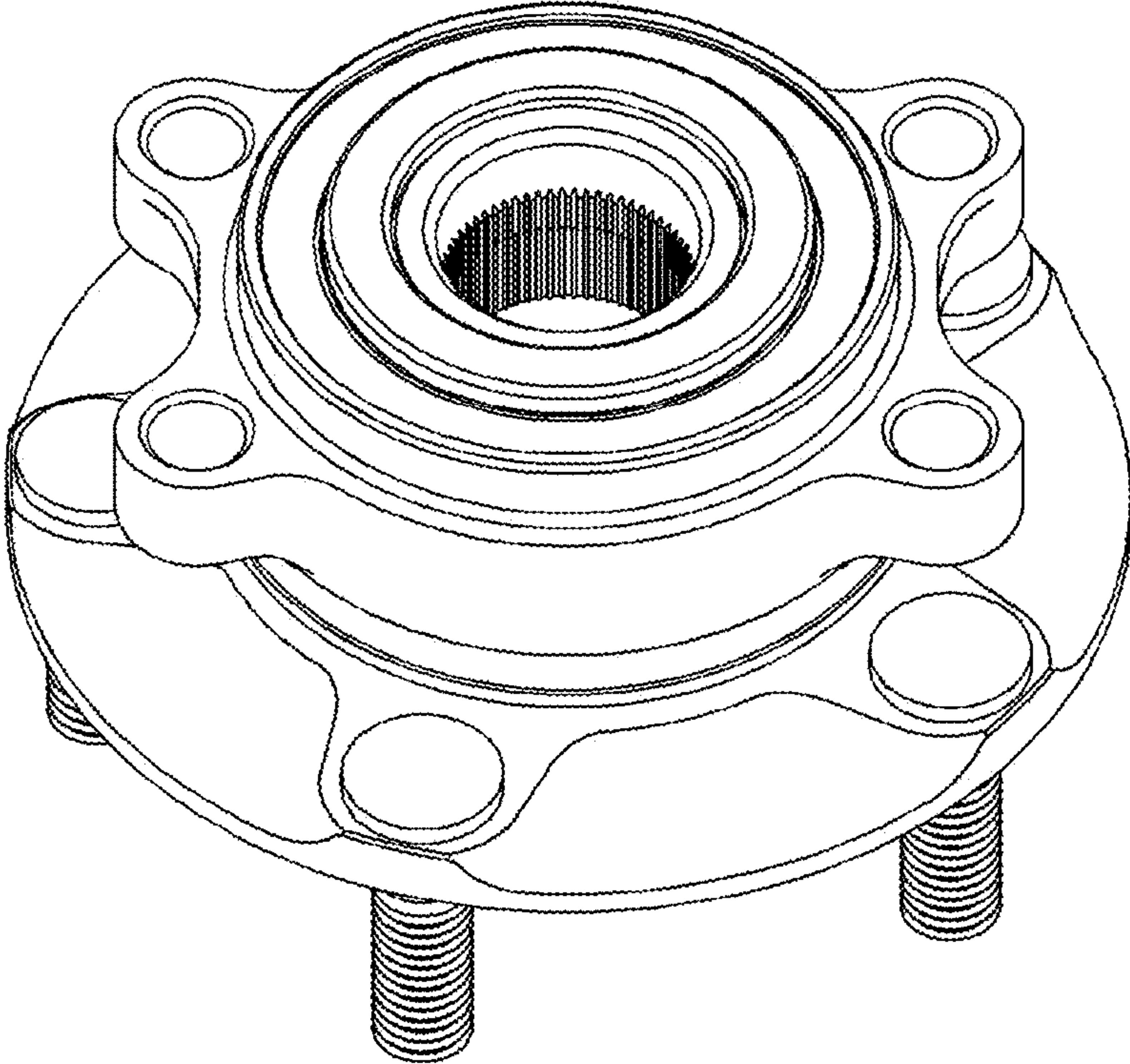

FIG. 36

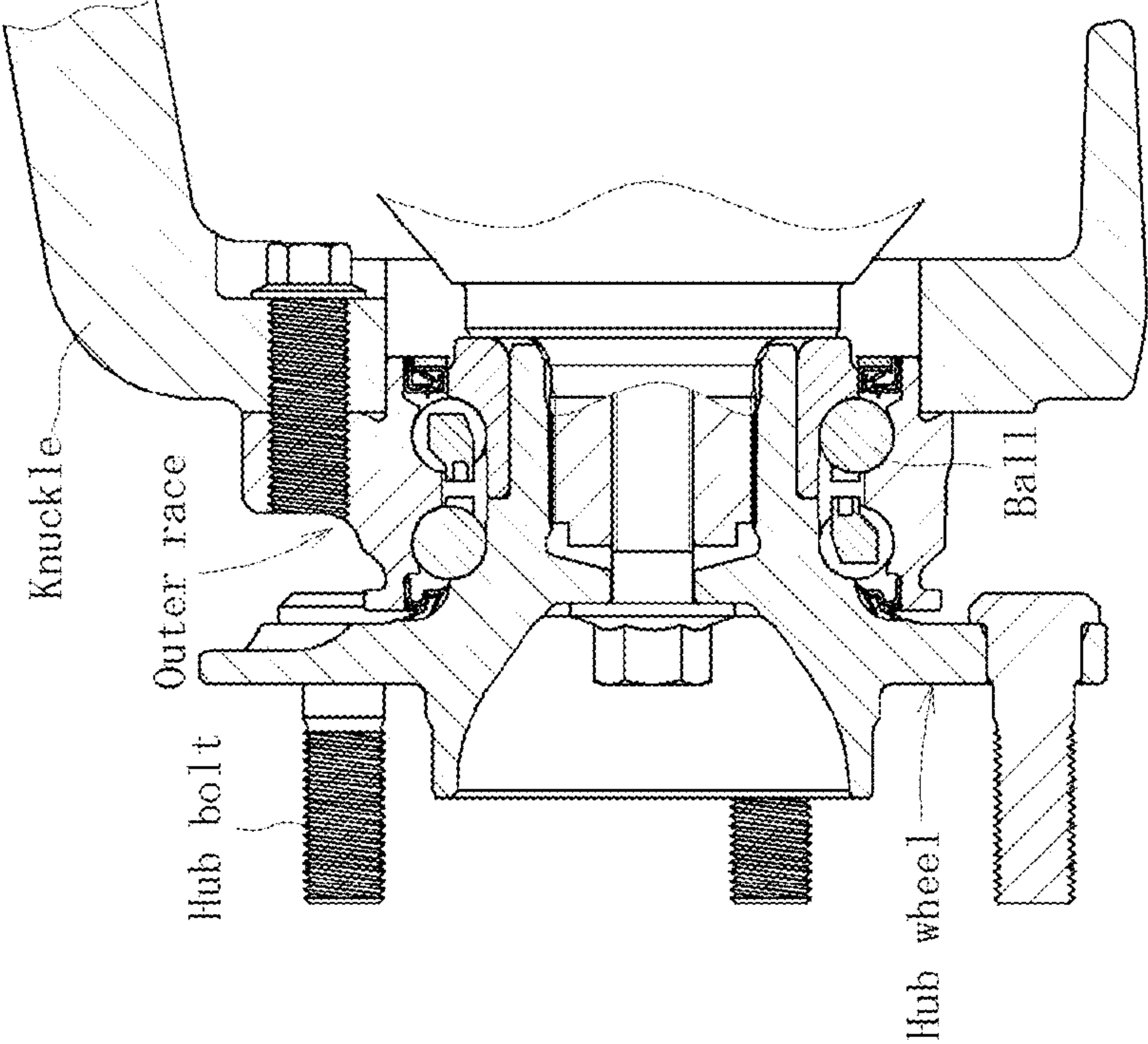

FIG. 37

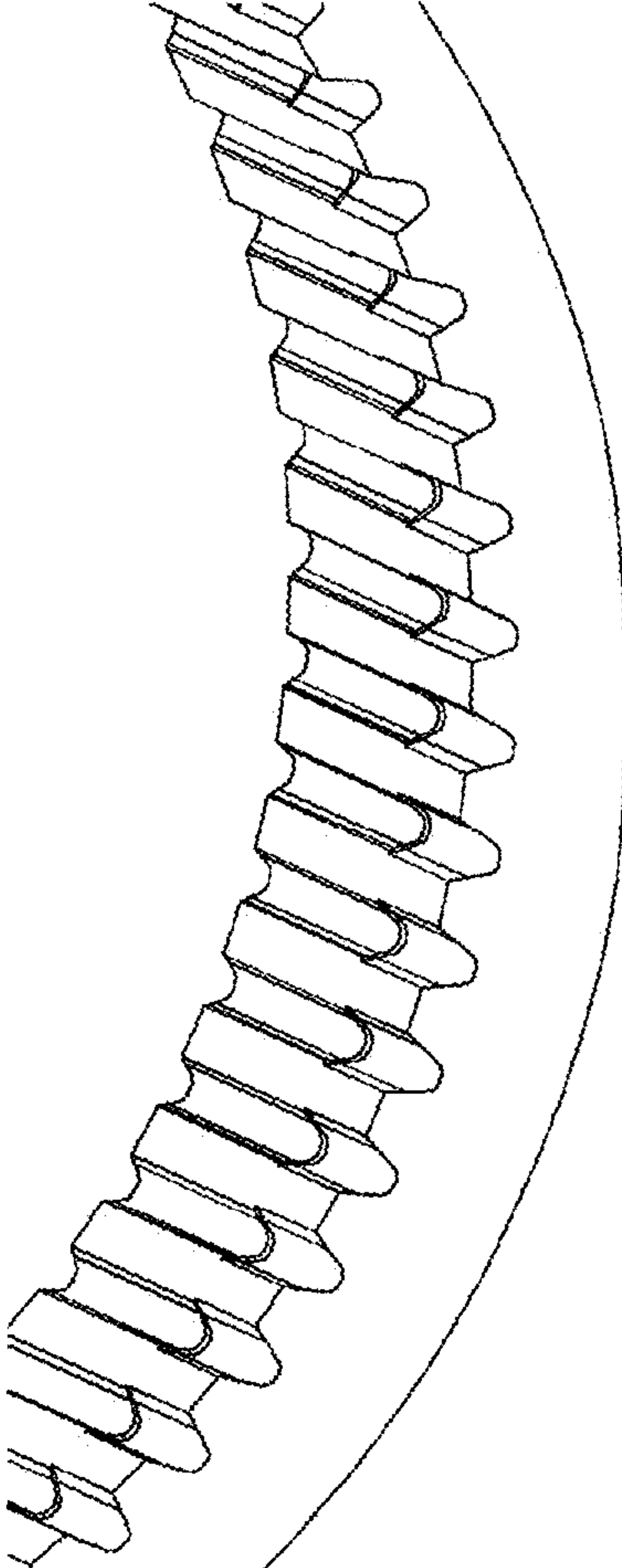

FIG. 38

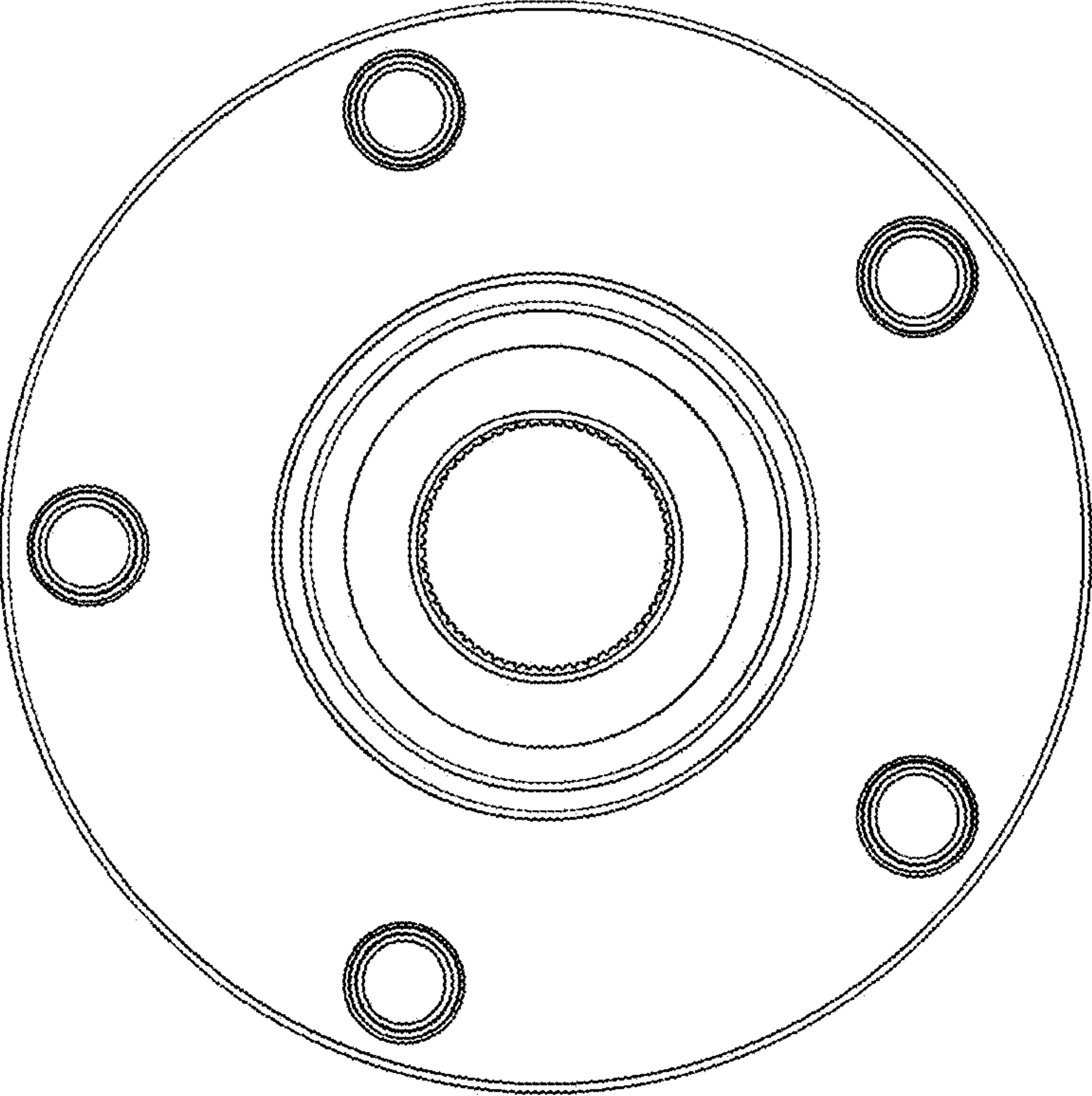

FIG. 39



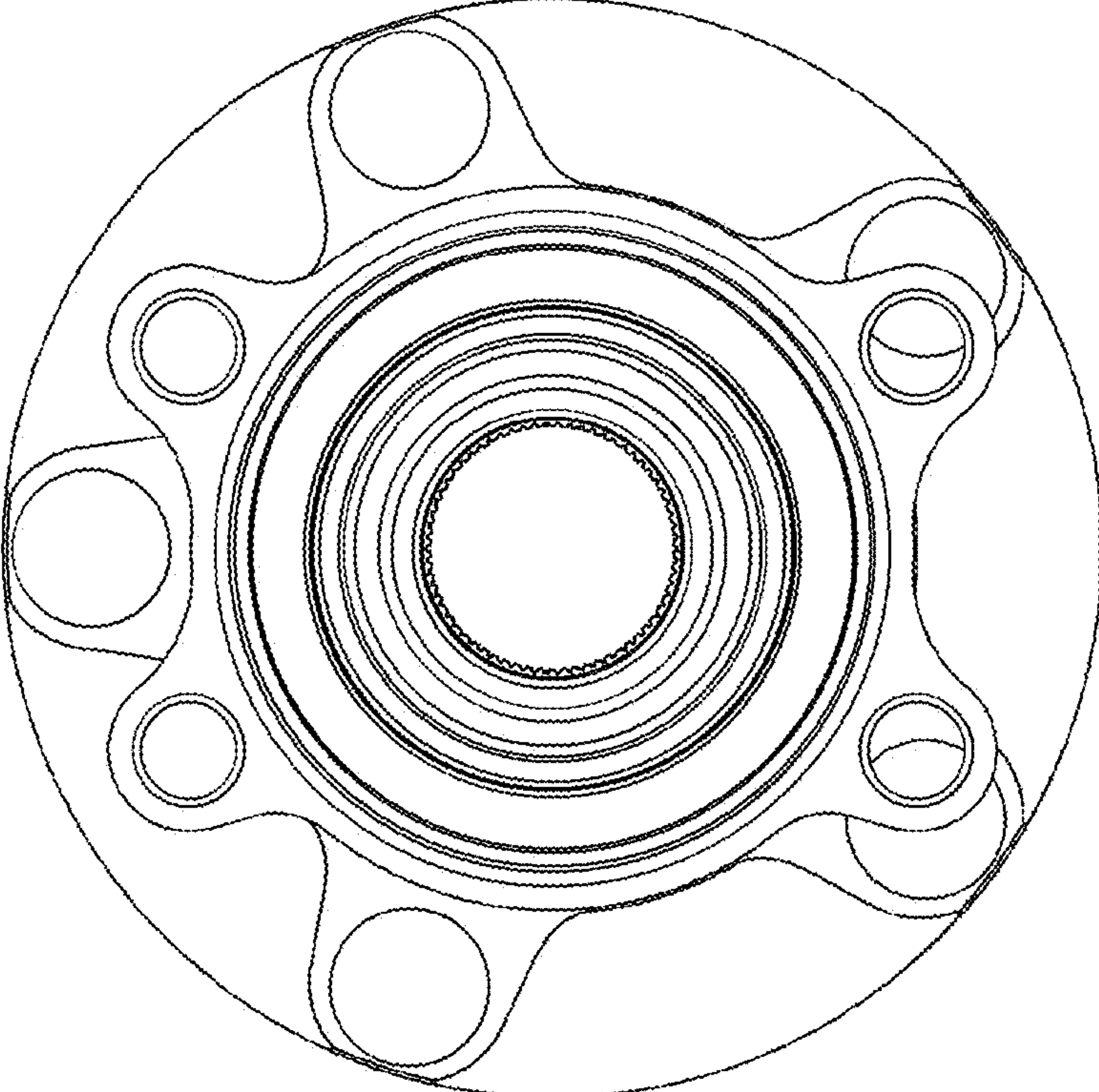

FIG. 40

FIG. 41

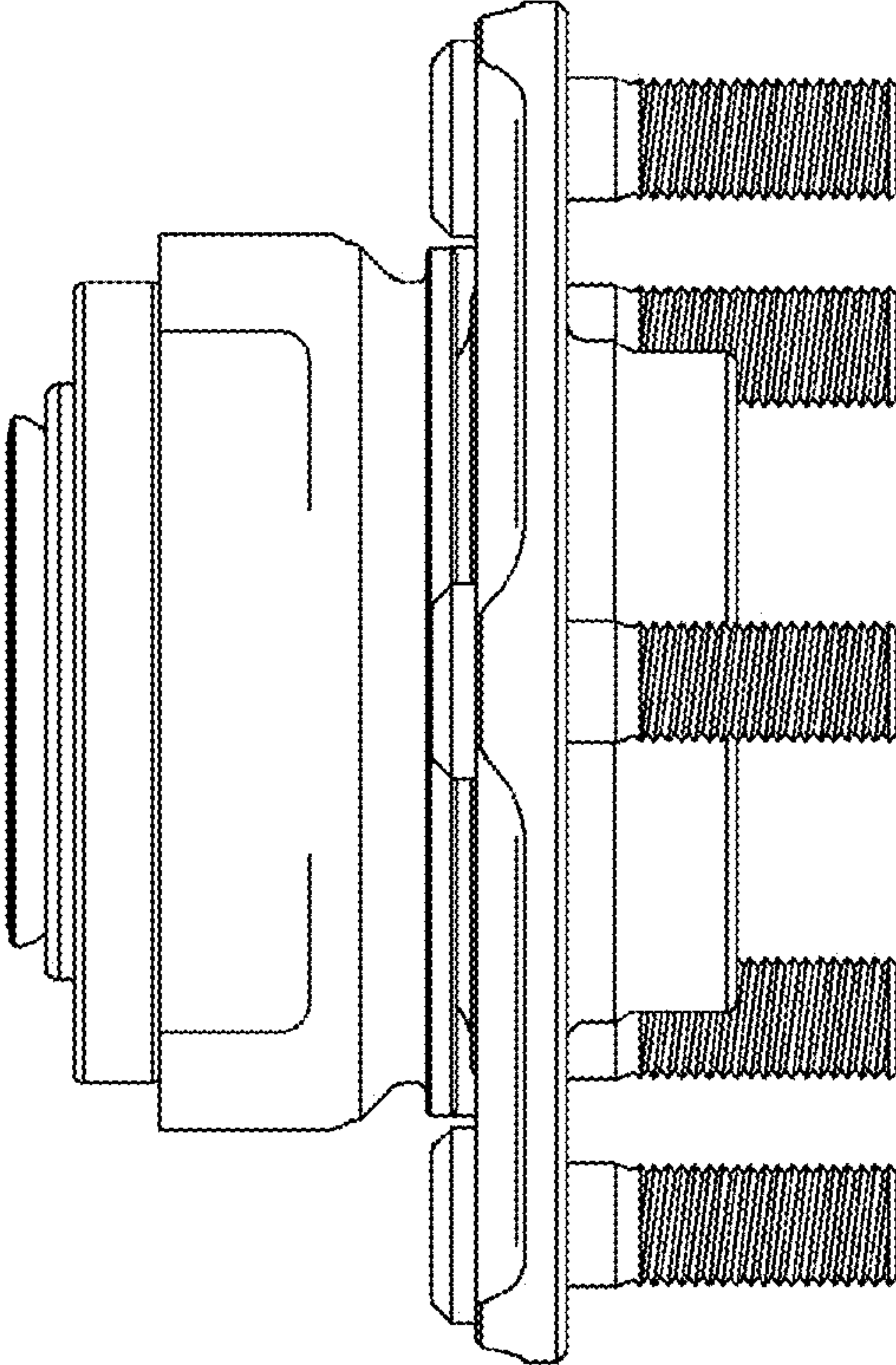
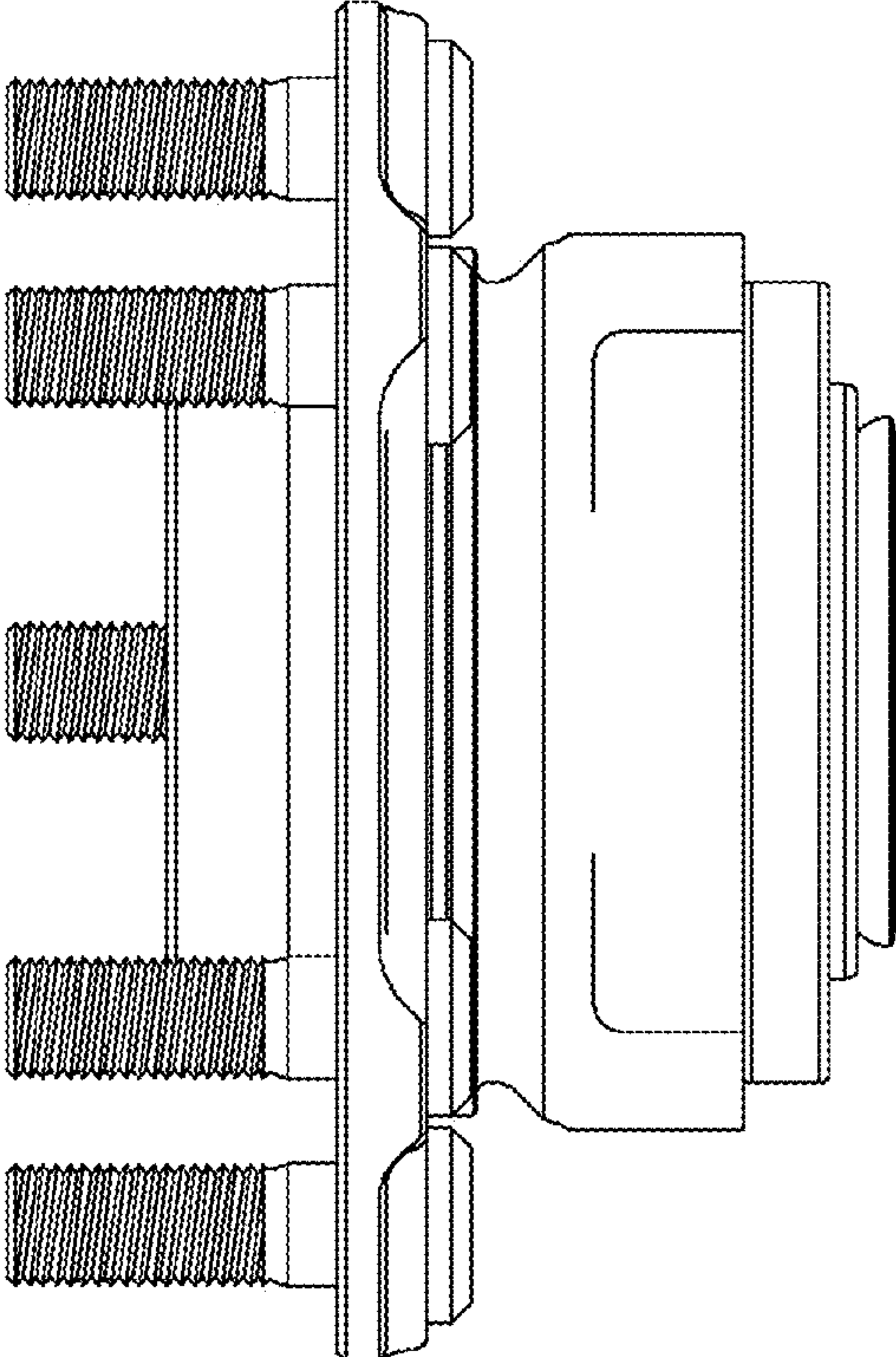

FIG. 42



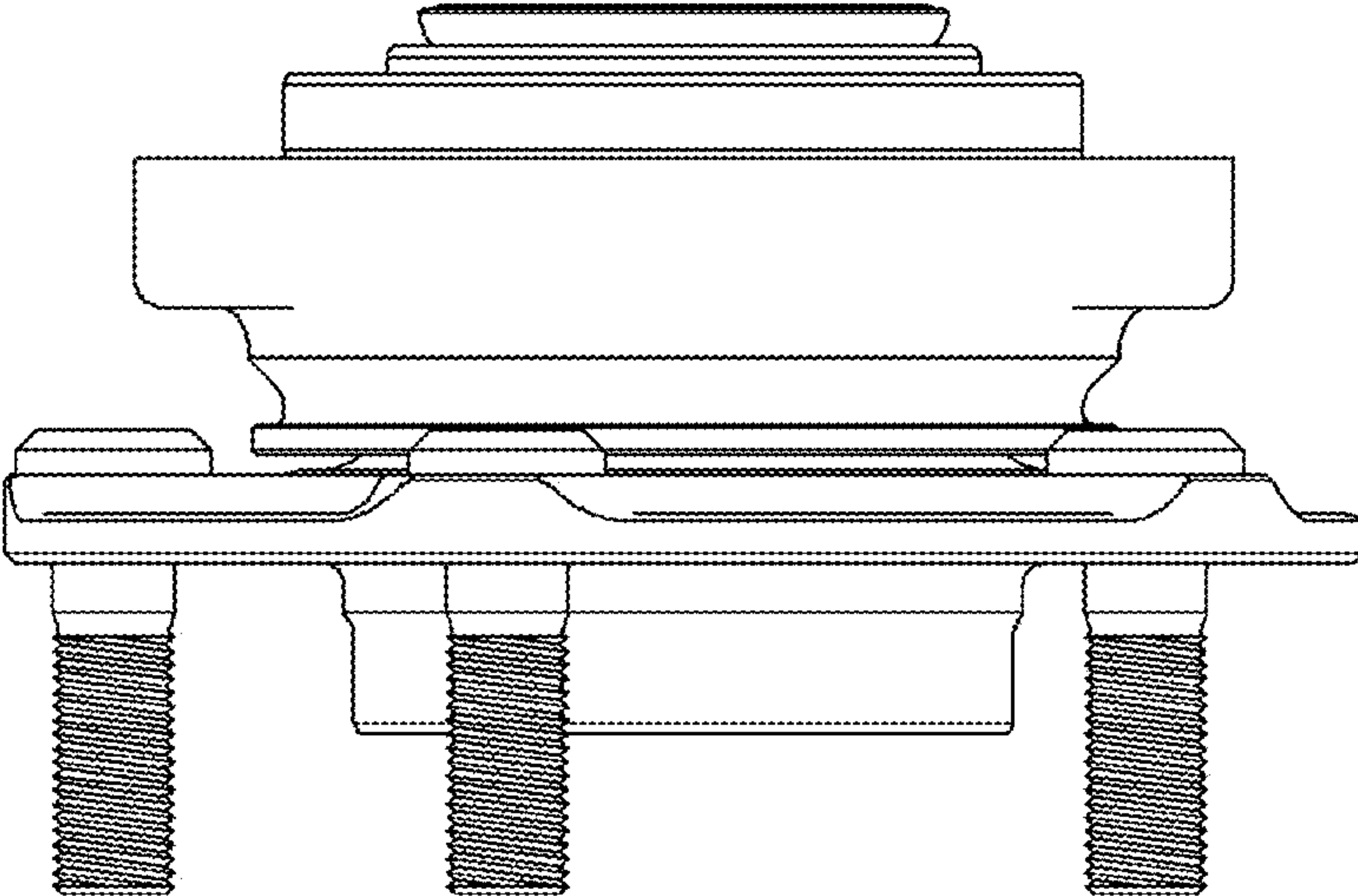

FIG. 43

FIG. 44

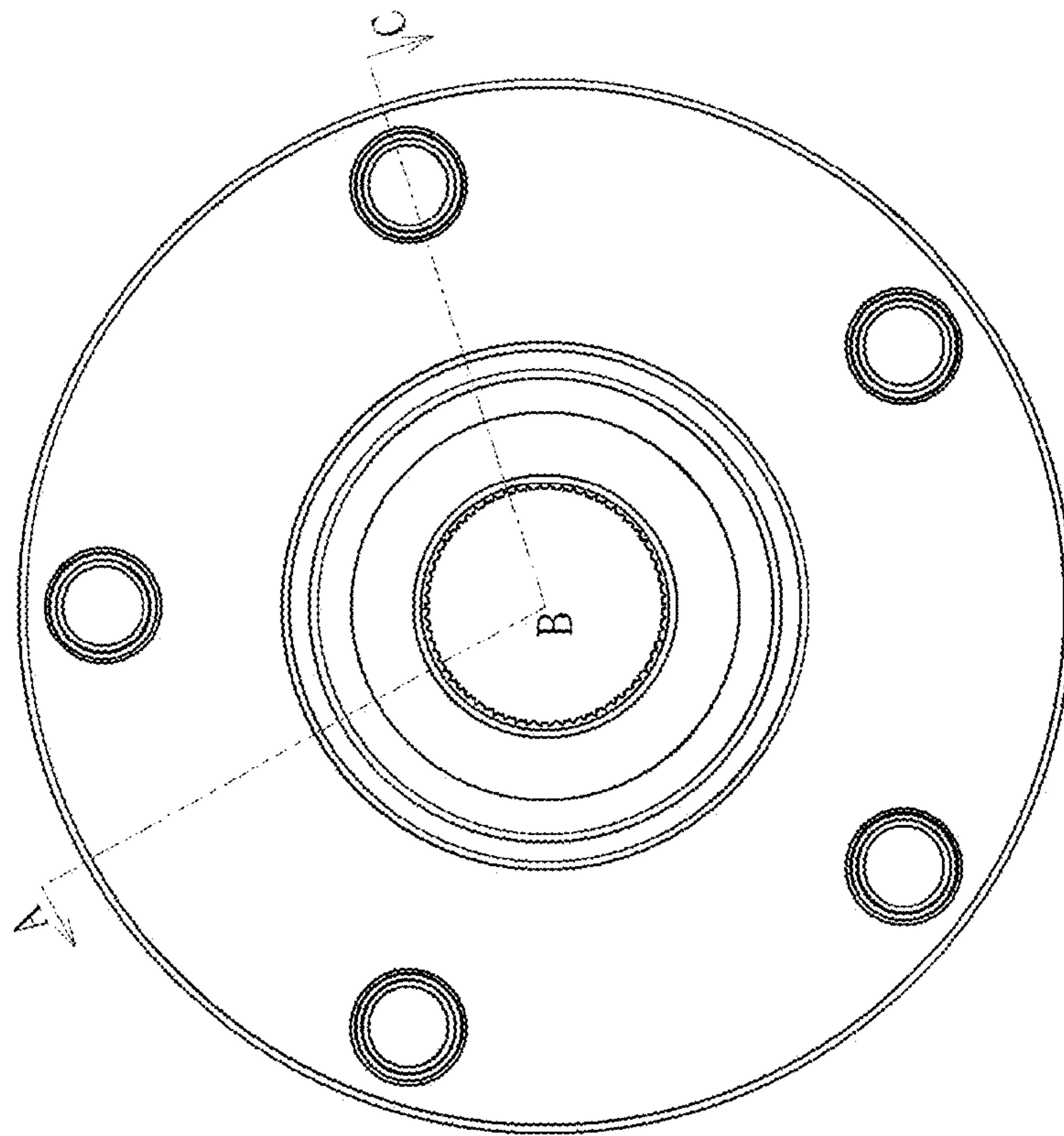

FIG. 45

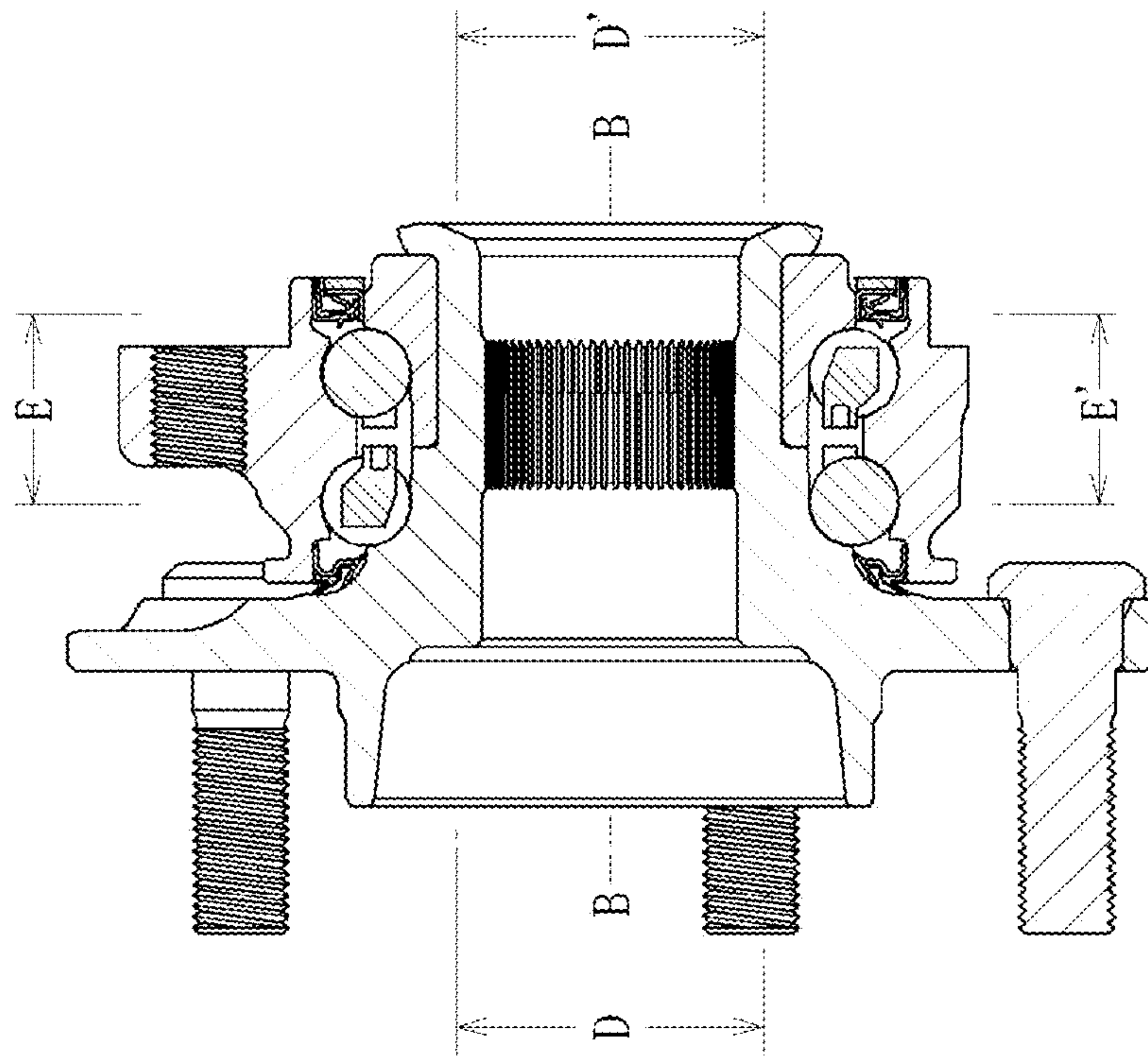
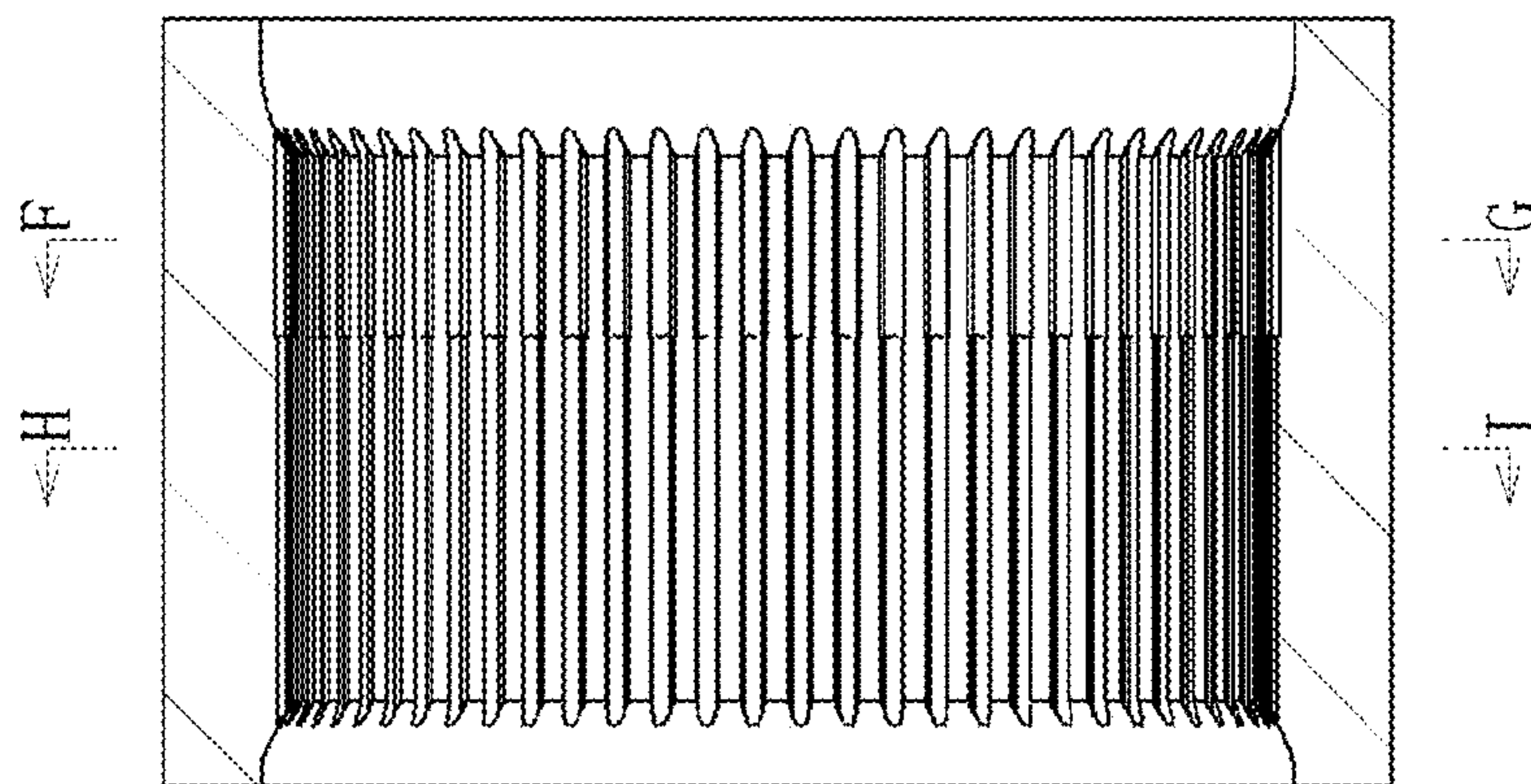



FIG. 46



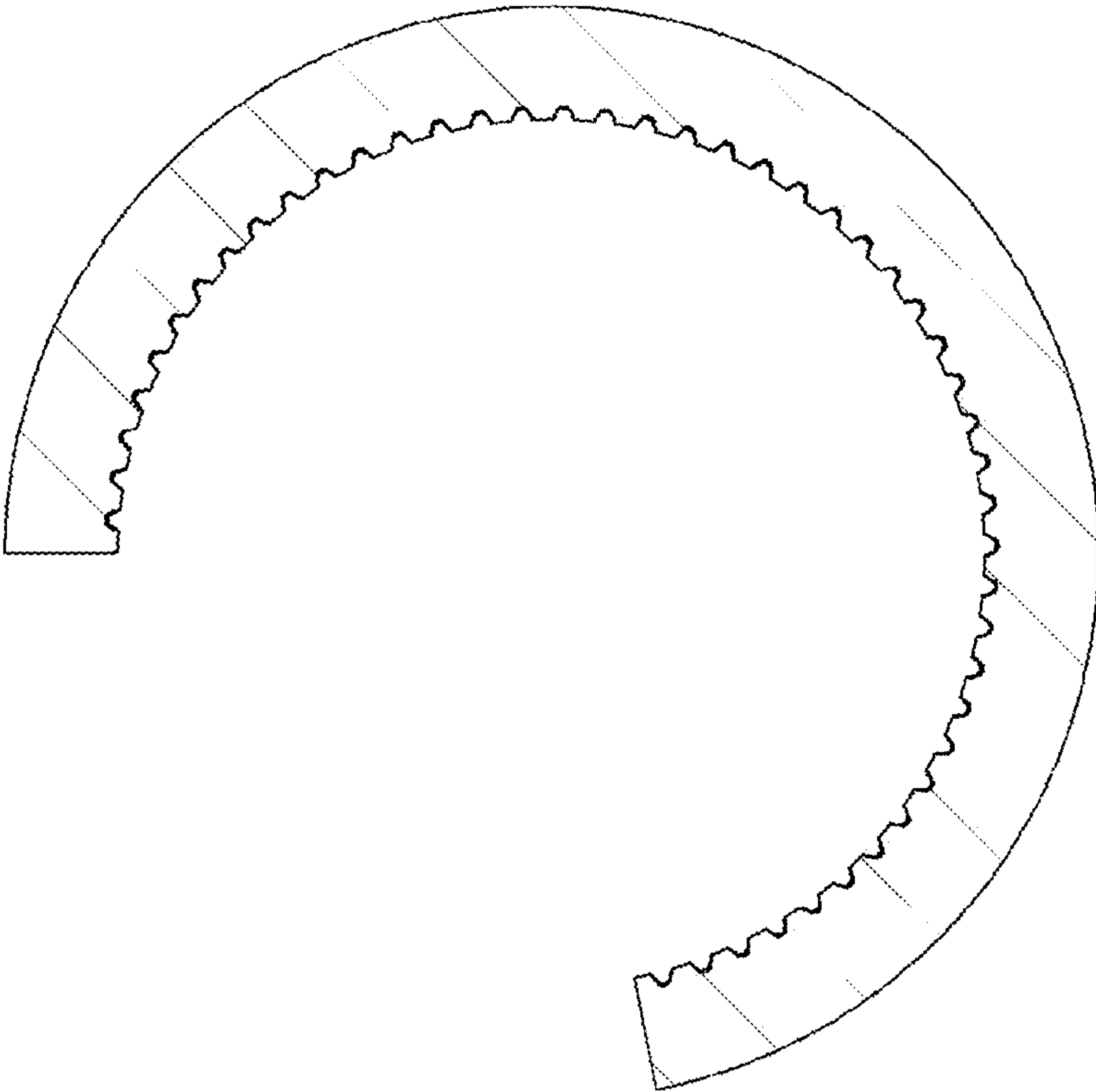

FIG. 47

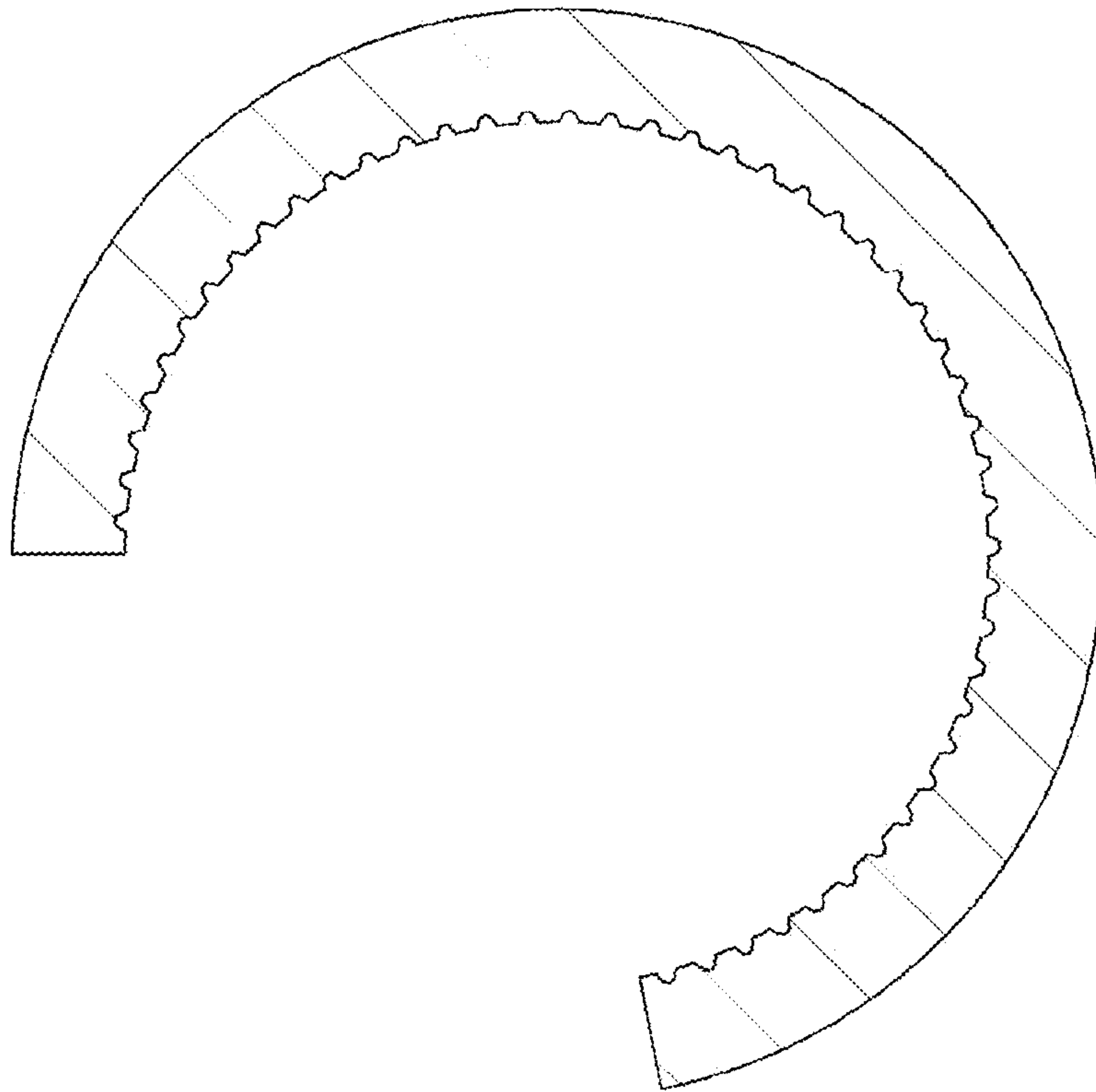

FIG. 48

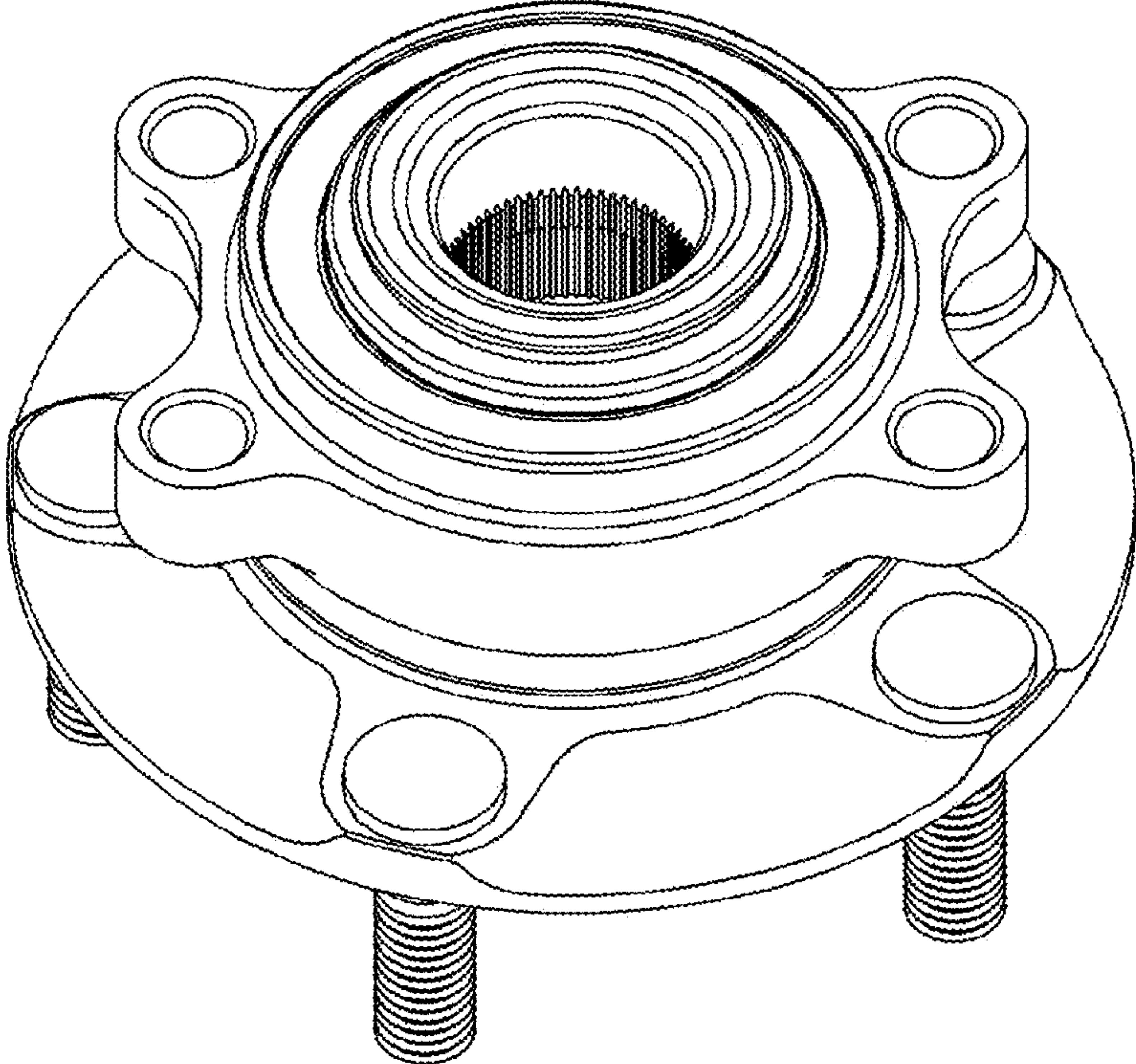

FIG. 49

FIG. 50

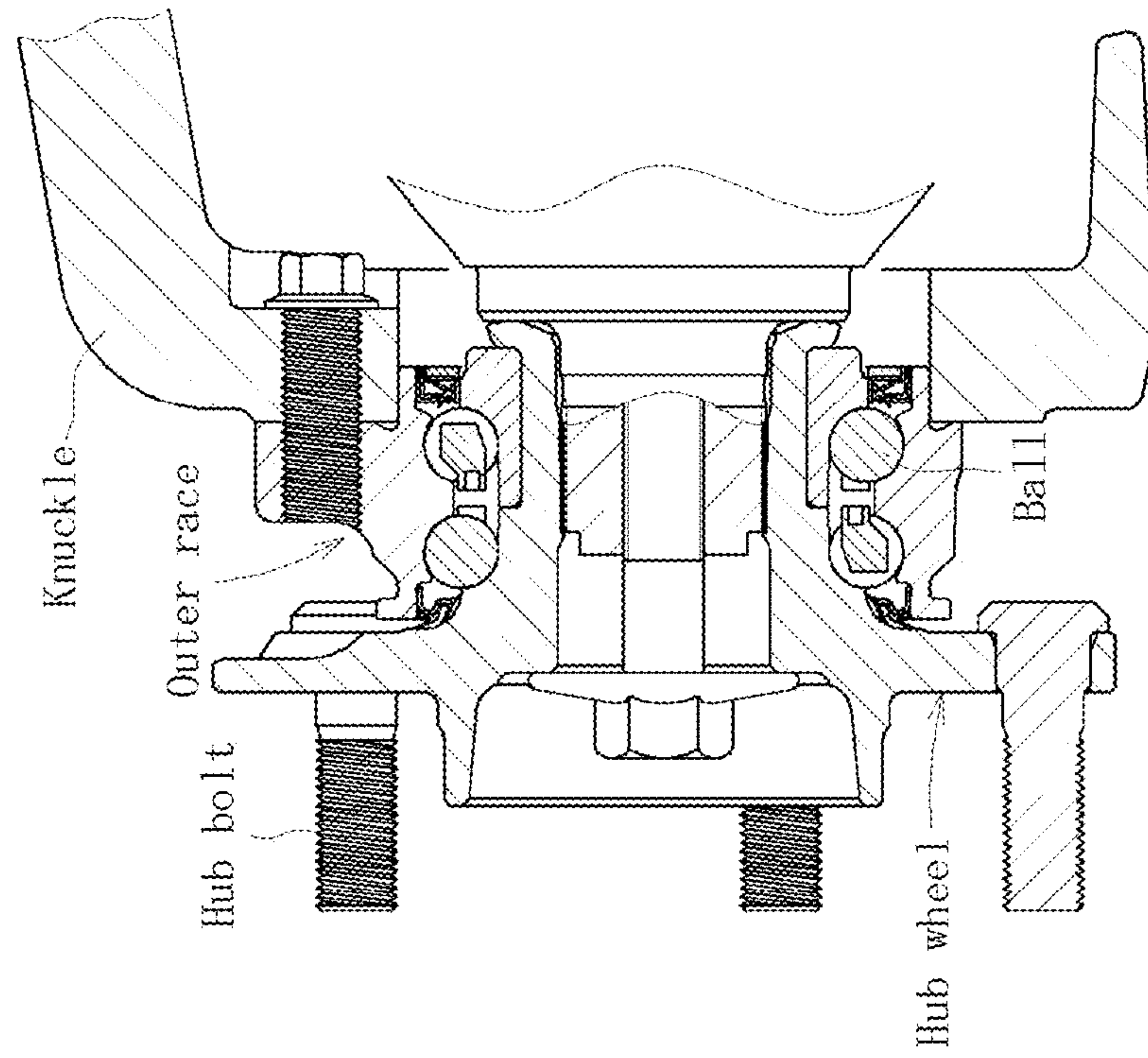
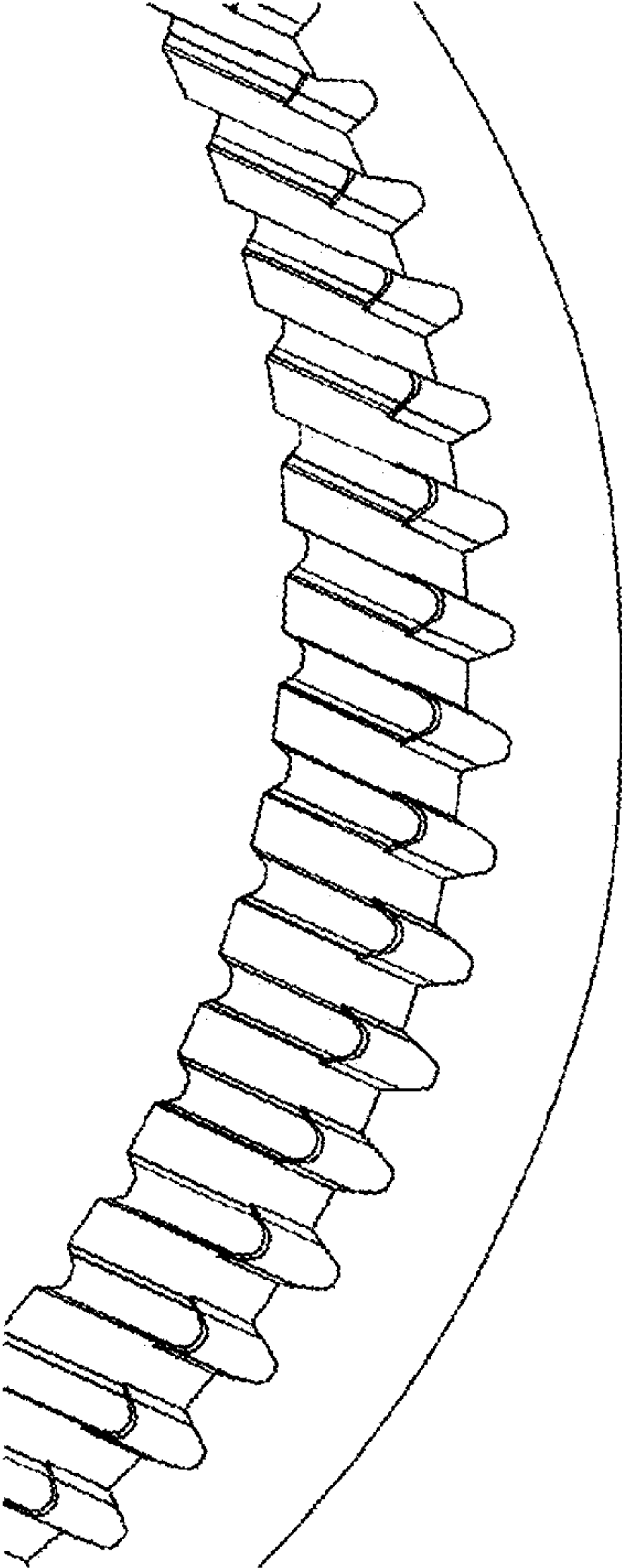

FIG. 51





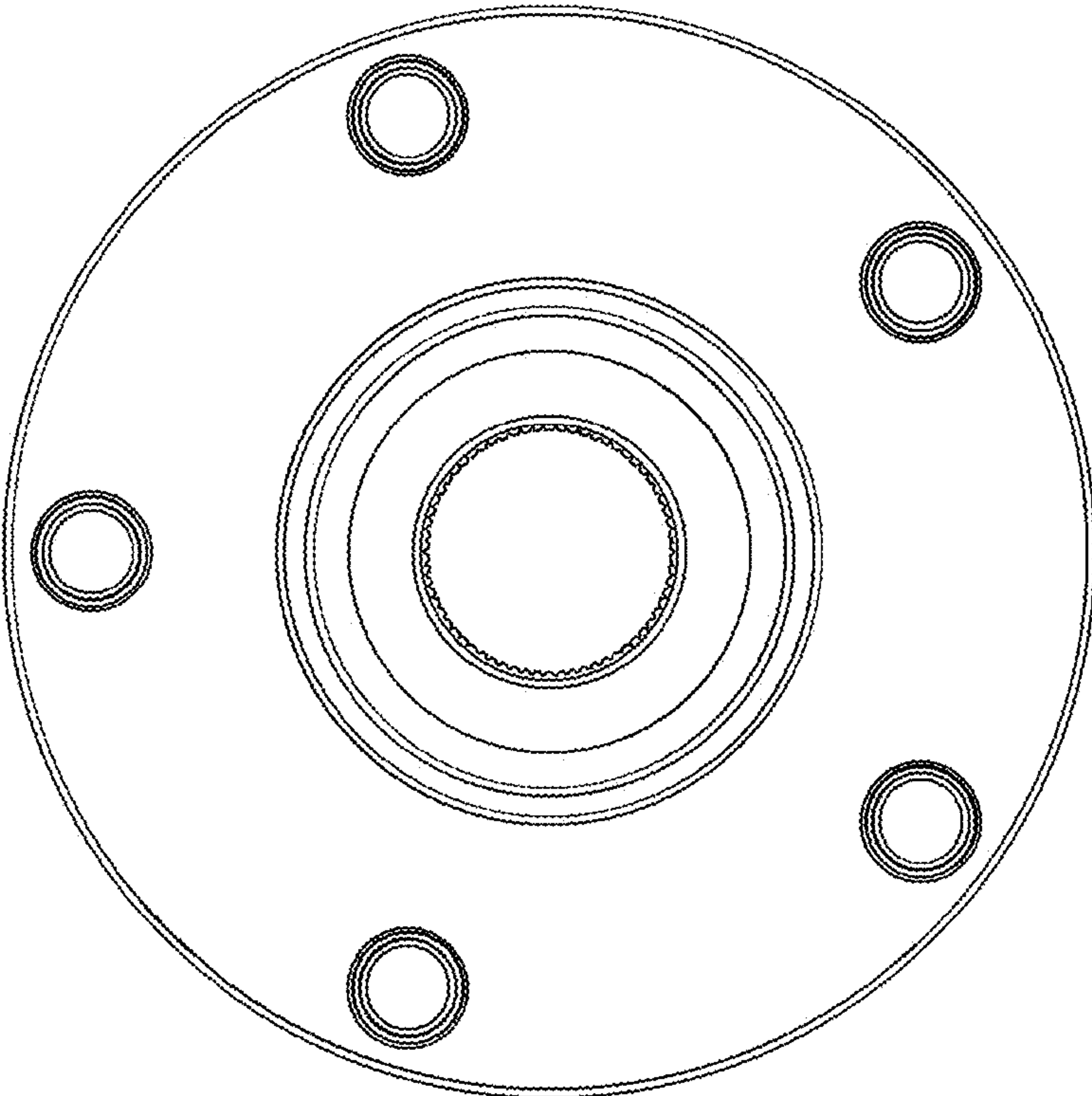

FIG. 52

FIG. 53

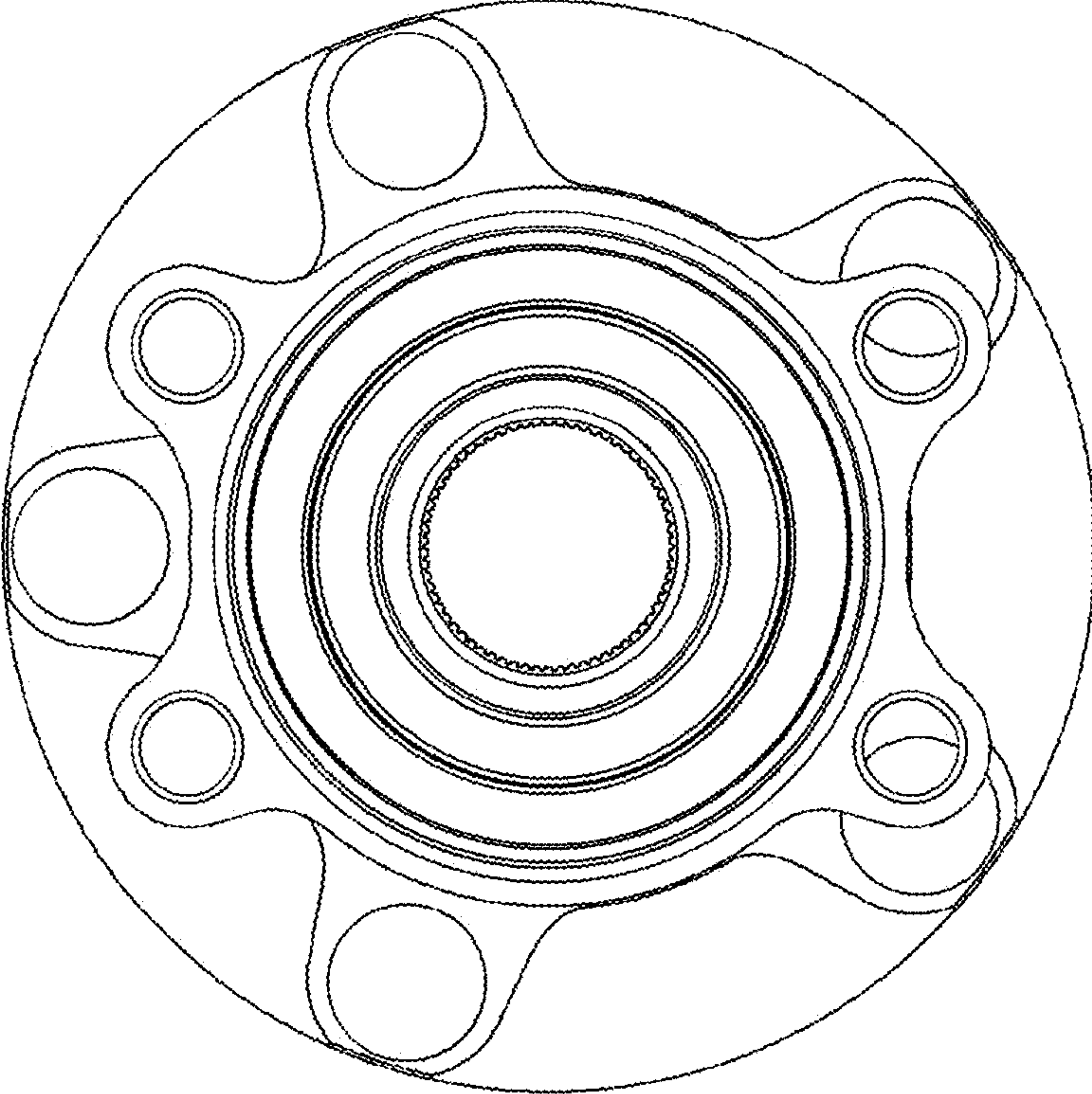

FIG. 54

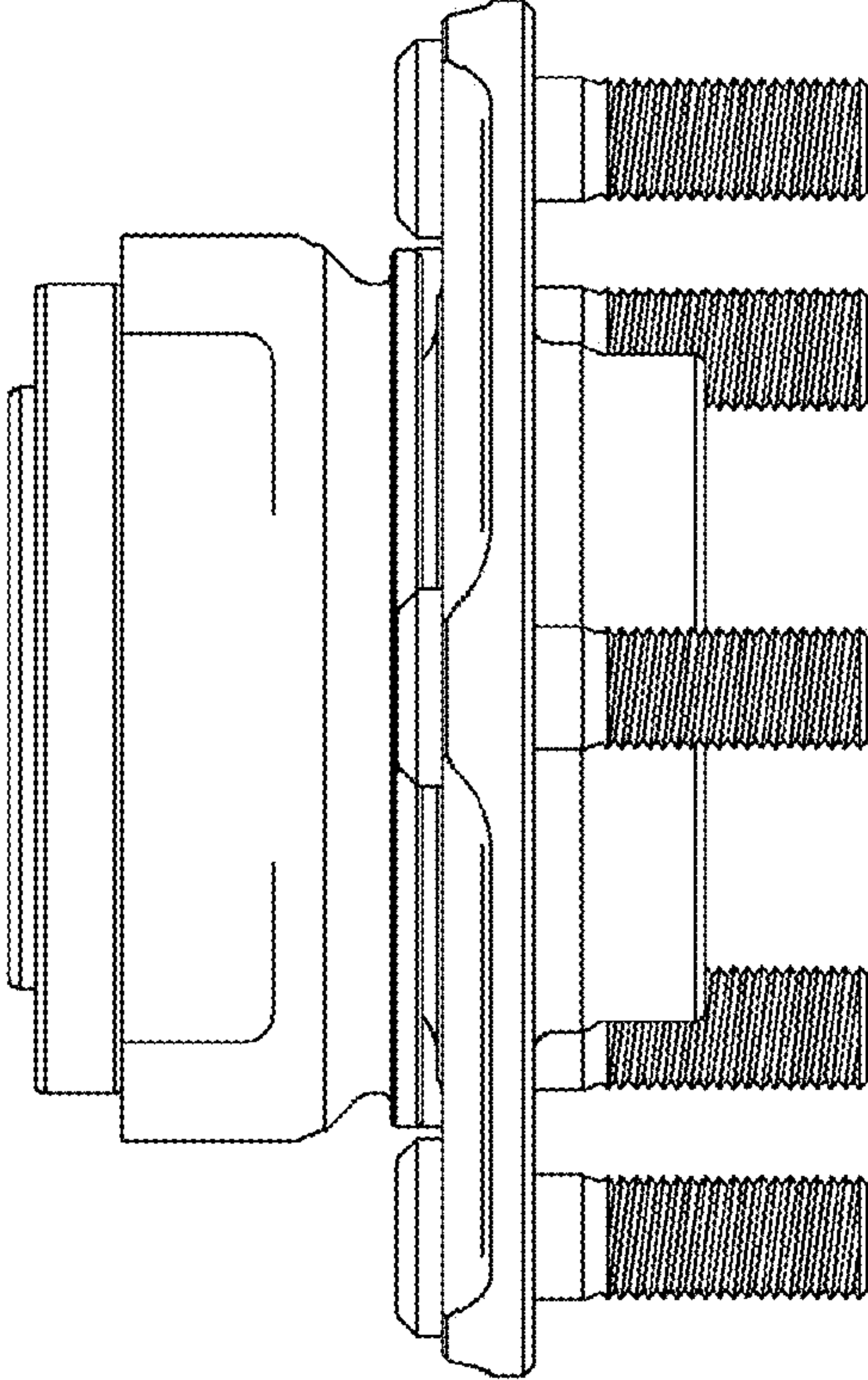

FIG. 55

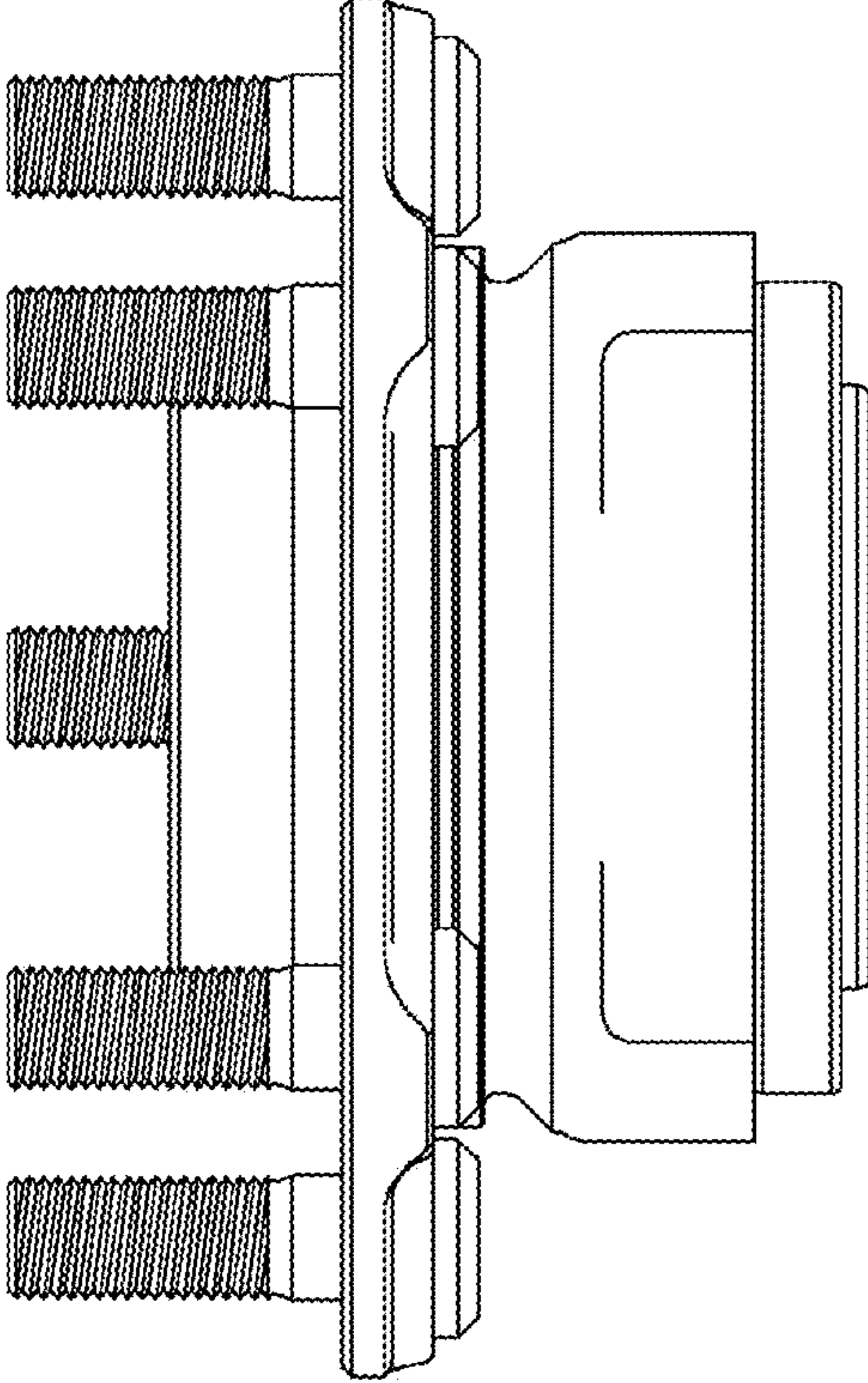

FIG. 56

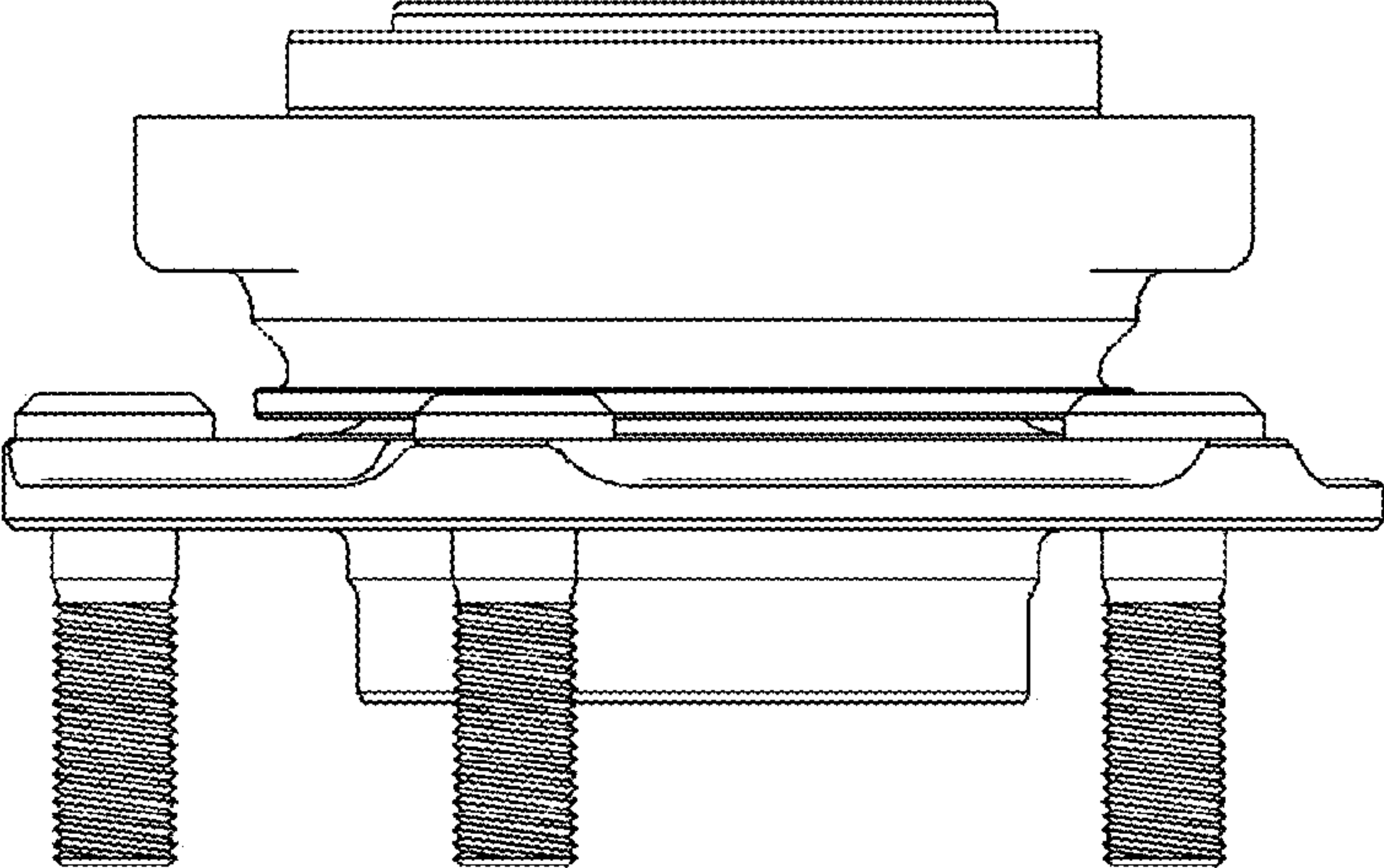

FIG. 57

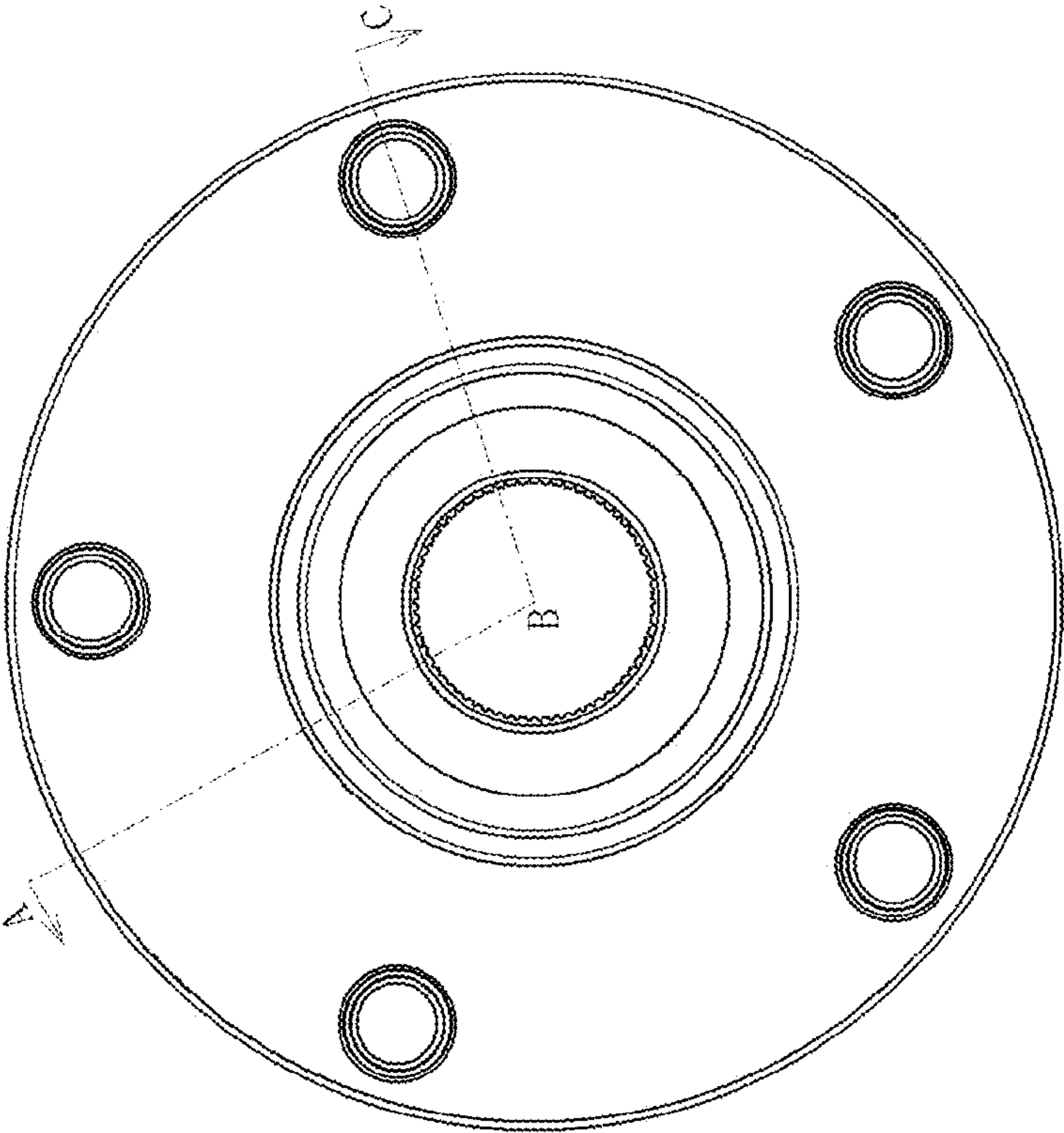



FIG. 58

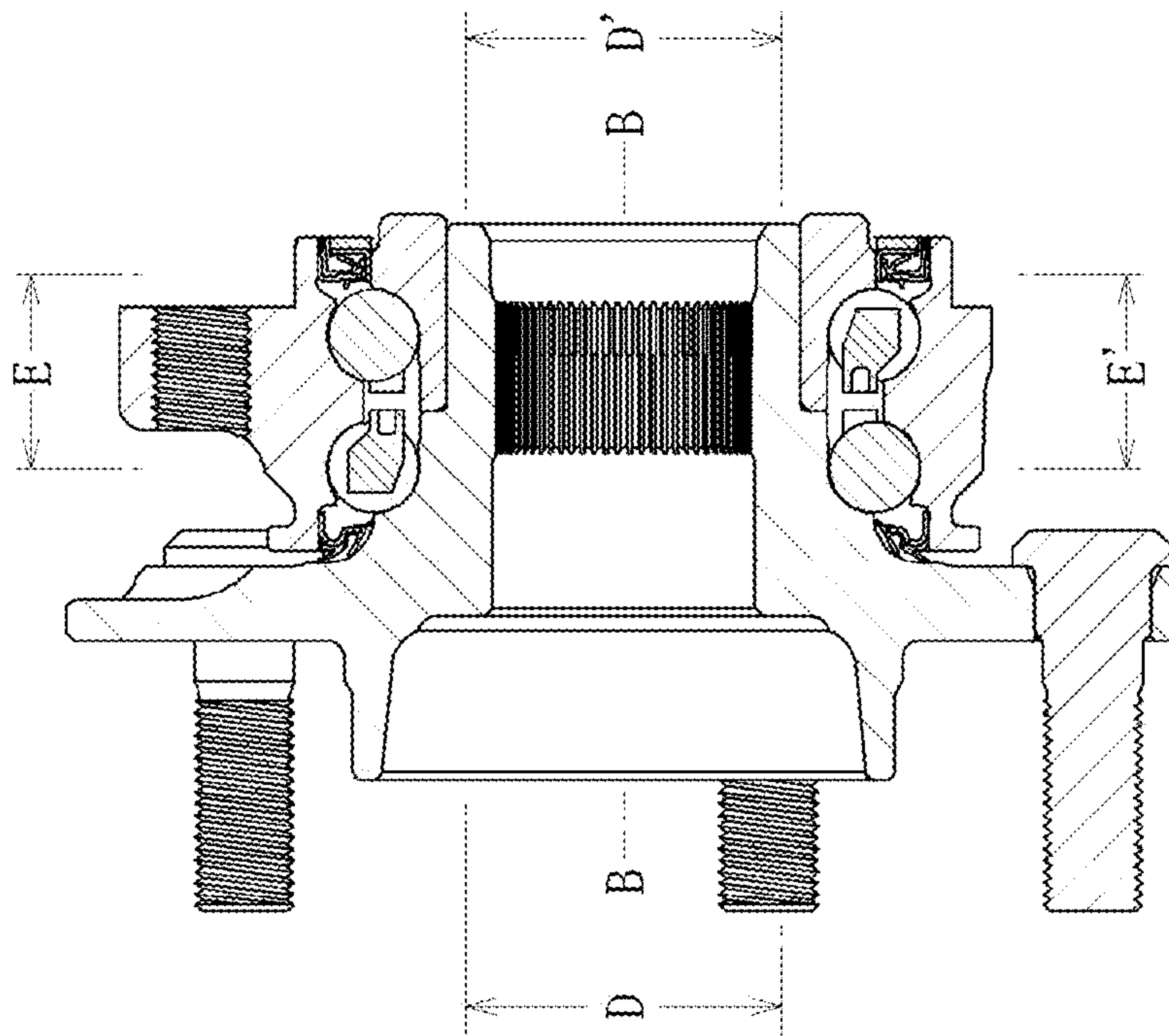
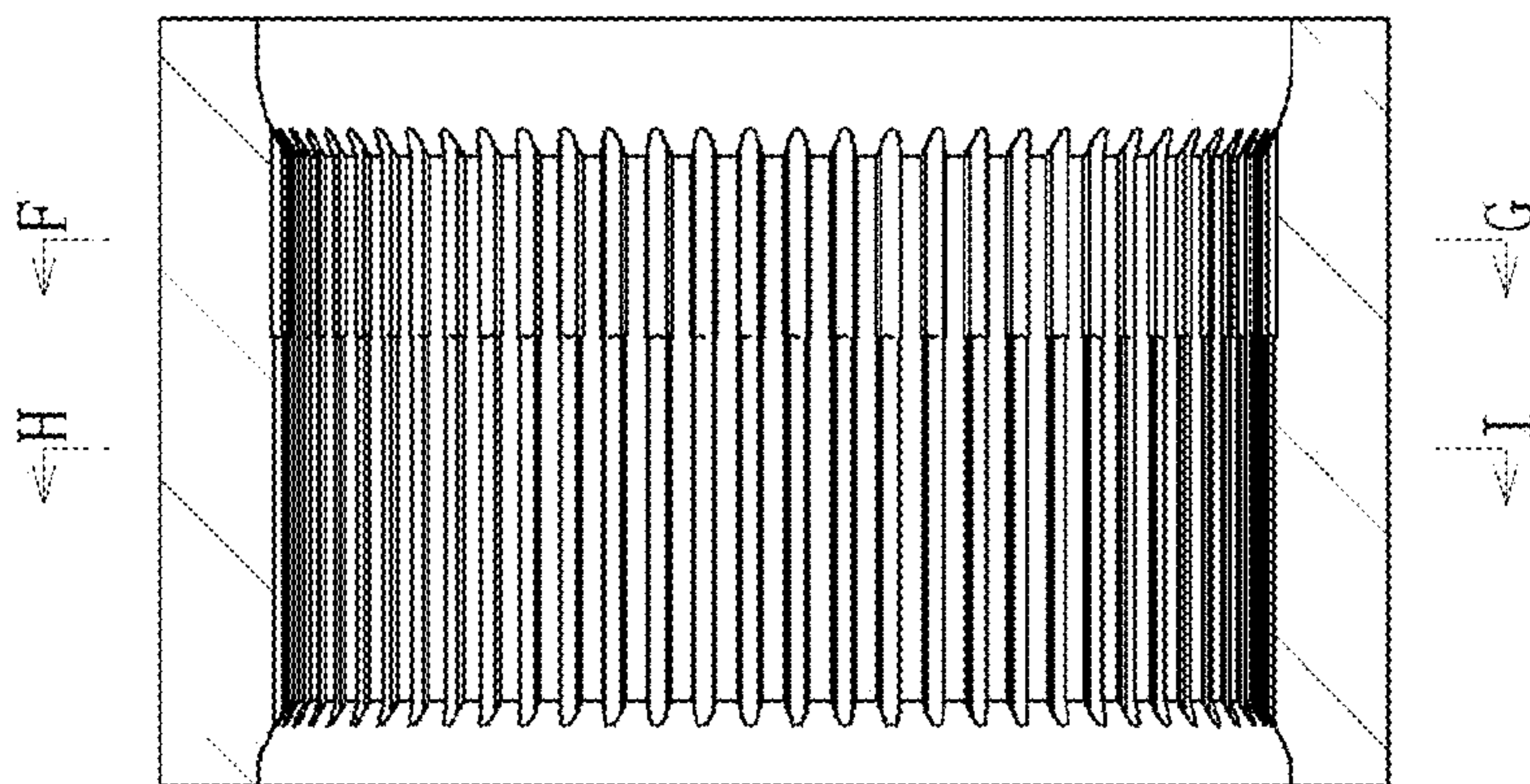

FIG. 59



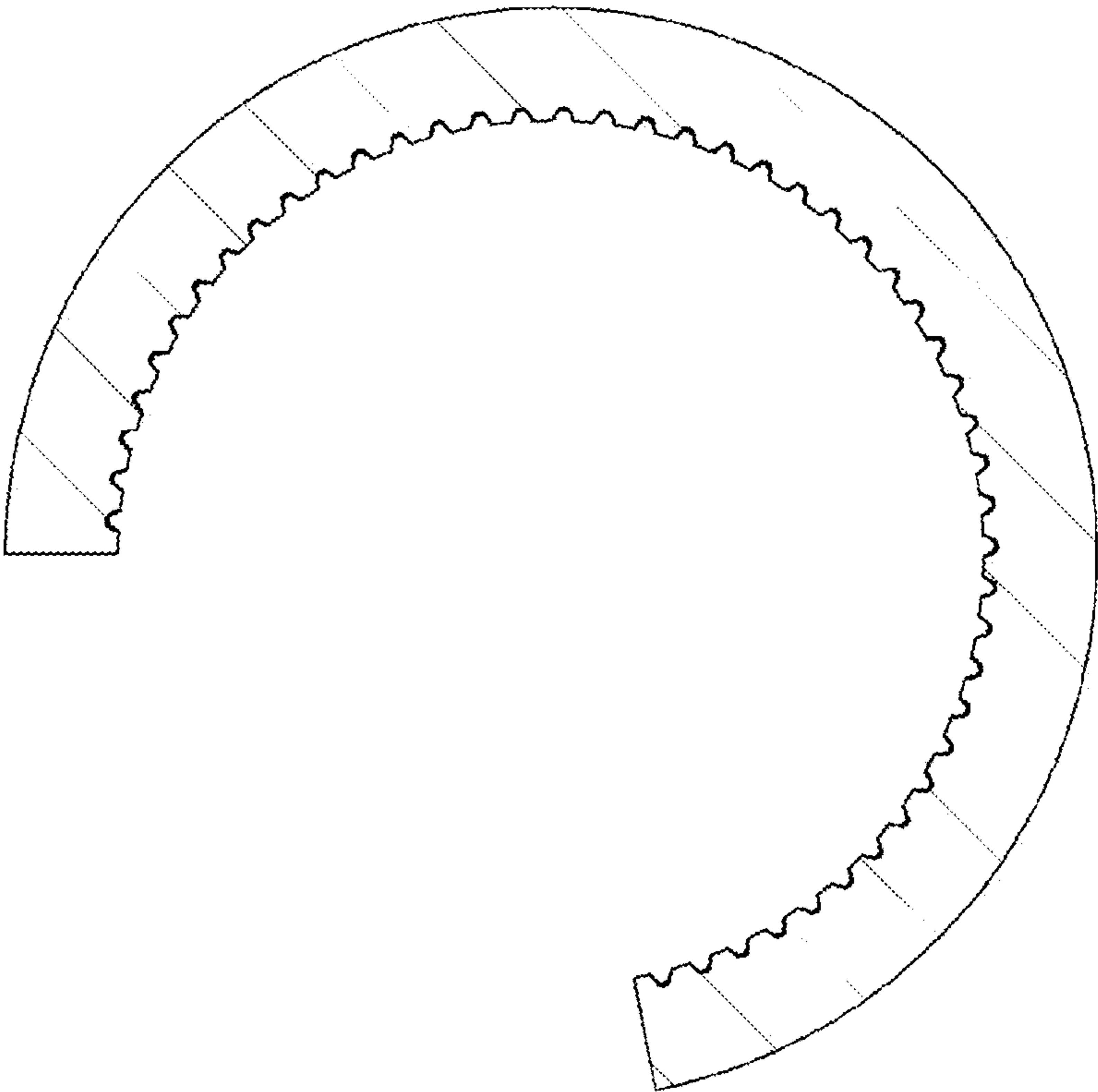

FIG. 60

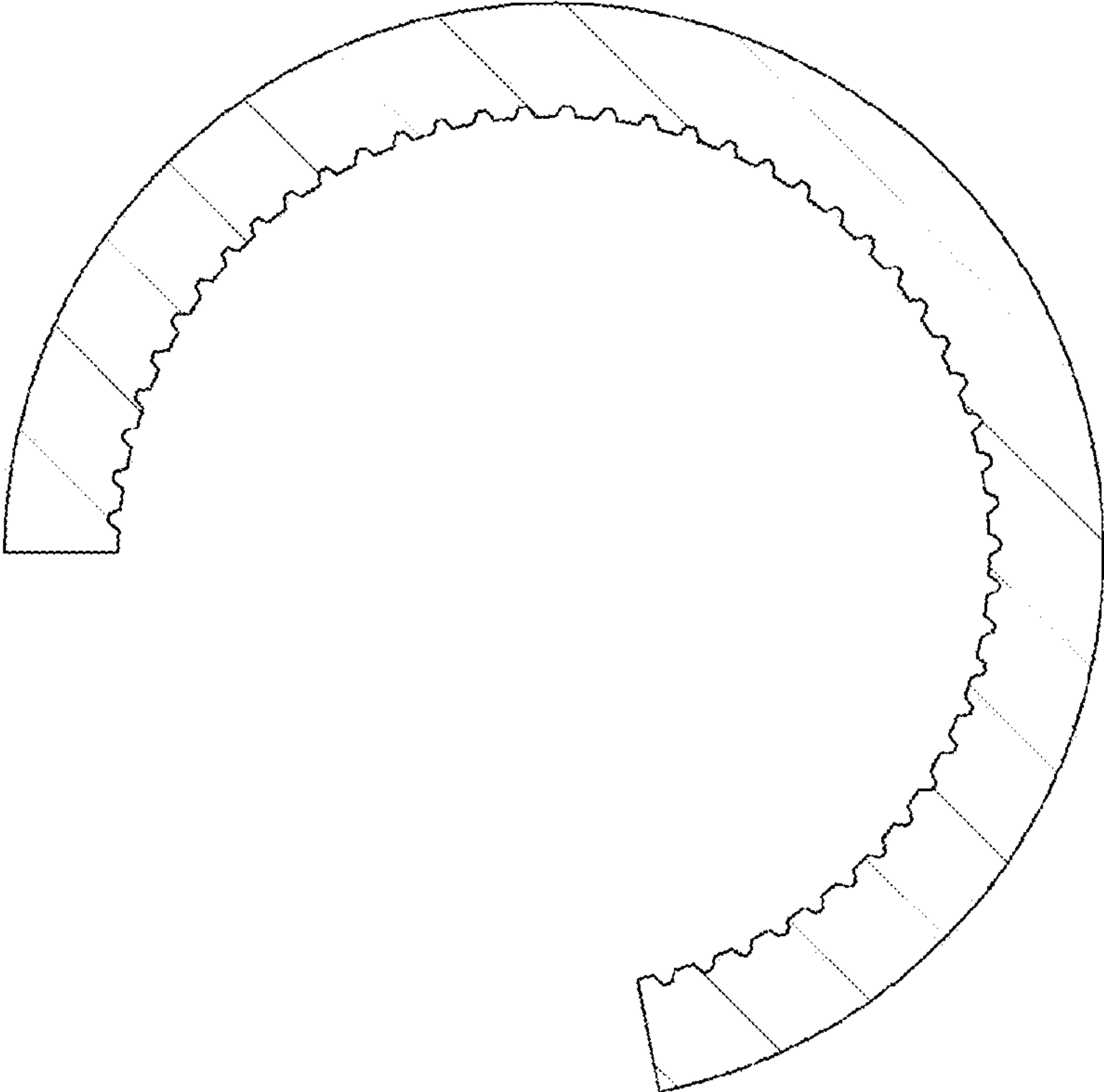

FIG. 61

FIG. 62

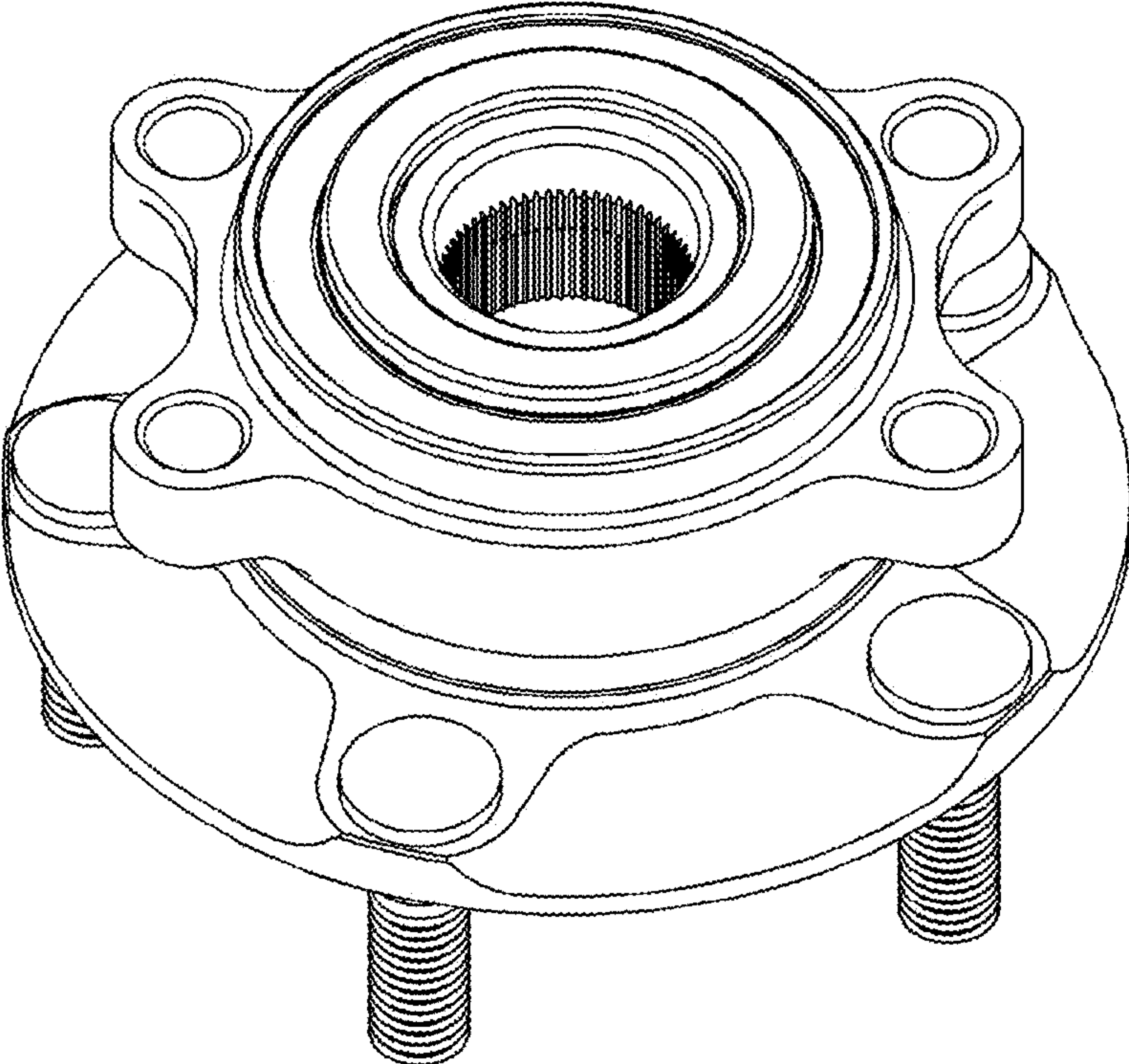

FIG. 63

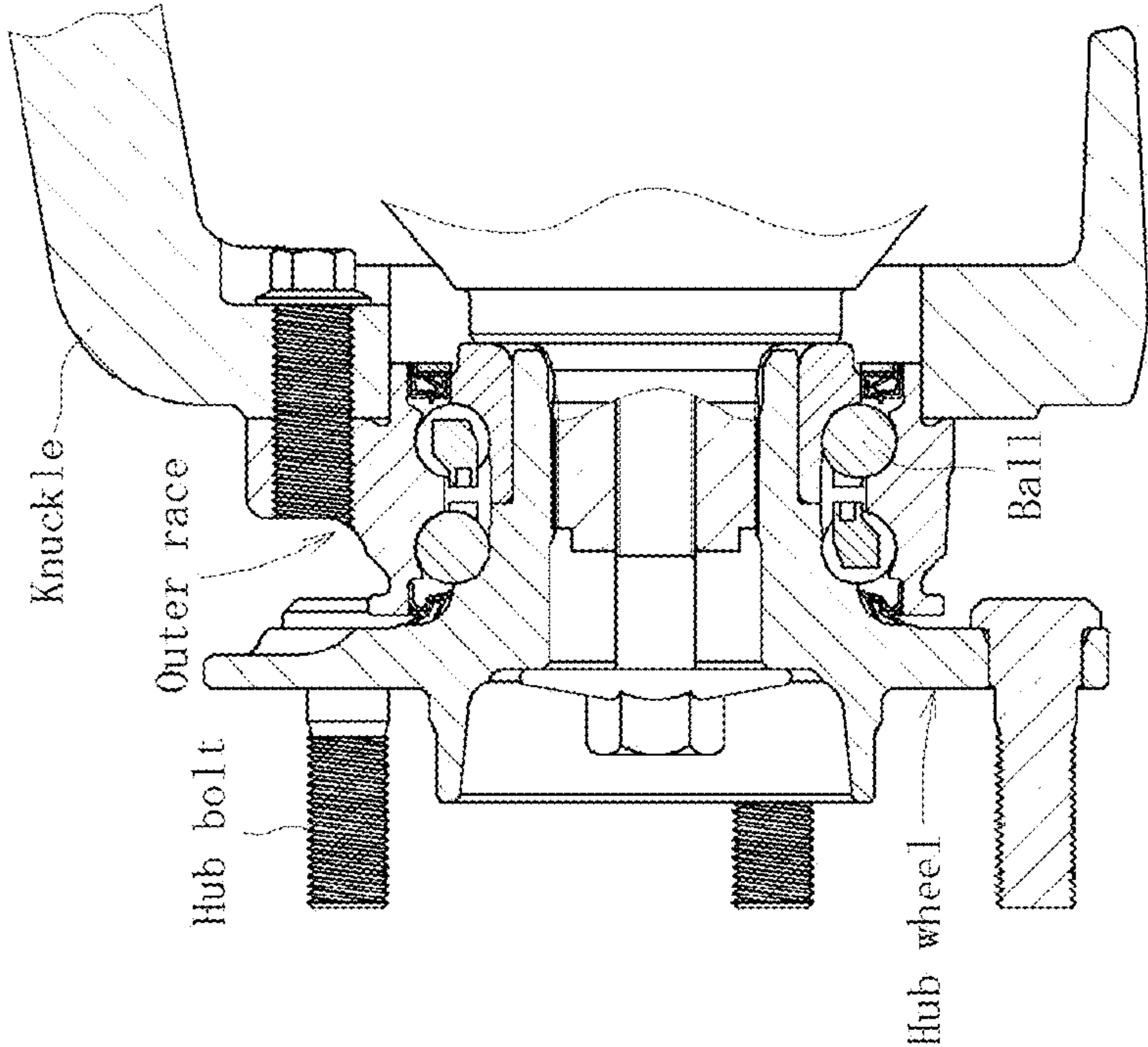



FIG. 64

