



US00D719435S

(12) **United States Design Patent**  
**Paulino et al.**

(10) **Patent No.:** **US D719,435 S**

(45) **Date of Patent:** **\*\* Dec. 16, 2014**

(54) **LATCH**

(71) Applicant: **Embraer S.A.**, São José dos Campos (BR)

(72) Inventors: **Amauri Paulino**, São José dos Campos (BR); **Sergio Luiz Abdalla Gomide**, São José dos Campos (BR); **Gustavo Selofite De Arruda**, São José dos Campos (BR); **Nilmar César Ferreira**, São José dos Campos (BR); **Luciano Dos Santos Ribeiro**, São José dos Campos (BR); **Demétrio Andrade De Campos**, São José dos Campos (BR); **Sergio Augusto Meireles Filho**, São José dos Campos (BR); **Frederico Lara De Oliveira**, São José dos Campos (BR); **Douglas Gonçalves De Albuquerque**, São José dos Campos (BR); **Helio Albino**, São José dos Campos (BR); **André Duarte Stein**, São José dos Campos (BR); **Paul Priestman**, London (GB); **Daniel MacInnes**, London (GB)

(73) Assignee: **Embraer S.A.**, São José dos Campos, SP (BR)

(\*\*) Term: **14 Years**

(21) Appl. No.: **29/469,014**

(22) Filed: **Oct. 4, 2013**

(51) **LOC (10) Cl.** ..... **08-07**

(52) **U.S. Cl.**  
USPC ..... **D8/331**

(58) **Field of Classification Search**  
CPC ..... E05B 55/00; E05B 3/00; E05B 63/0017;  
E05C 17/48; E05C 19/028; B62D 33/037;  
B62D 55/02; B65F 1/615

USPC ..... D8/330, 331, 335, 339, 302, 343;  
70/141, 208, 448, 206, 210; 292/336.3,  
292/169, 358, 359, 170, 175, 165, 224,  
292/140-145, 240-242, DIG. 14, DIG. 30,  
292/DIG. 31, DIG. 4, 173, DIG. 51, 337  
See application file for complete search history.

(56) **References Cited**

U.S. PATENT DOCUMENTS

4,832,384 A \* 5/1989 Venable ..... 292/87  
D458,110 S \* 6/2002 Landeros ..... D8/338

(Continued)

*Primary Examiner* — Prabhakar Deshmukh

(74) *Attorney, Agent, or Firm* — Nixon & Vanderhye P.C.

(57) **CLAIM**

The ornamental design for a “latch,” as shown and described.

**DESCRIPTION**

FIG. 1 is a front and left side perspective view of a latch showing our new design;

FIG. 2 is an enlarged front and left side perspective view thereof;

FIG. 3 is an enlarged front and right side perspective view thereof;

FIG. 4 is an enlarged front elevation view thereof; and,

FIG. 5 is an enlarged sectional view thereof, taken along line 5-5 of FIG. 4.

The broken lines indicate environment and form no part of the claimed design. The dot-dash lines represent boundary cuts and form no part of the claimed design.

**1 Claim, 3 Drawing Sheets**

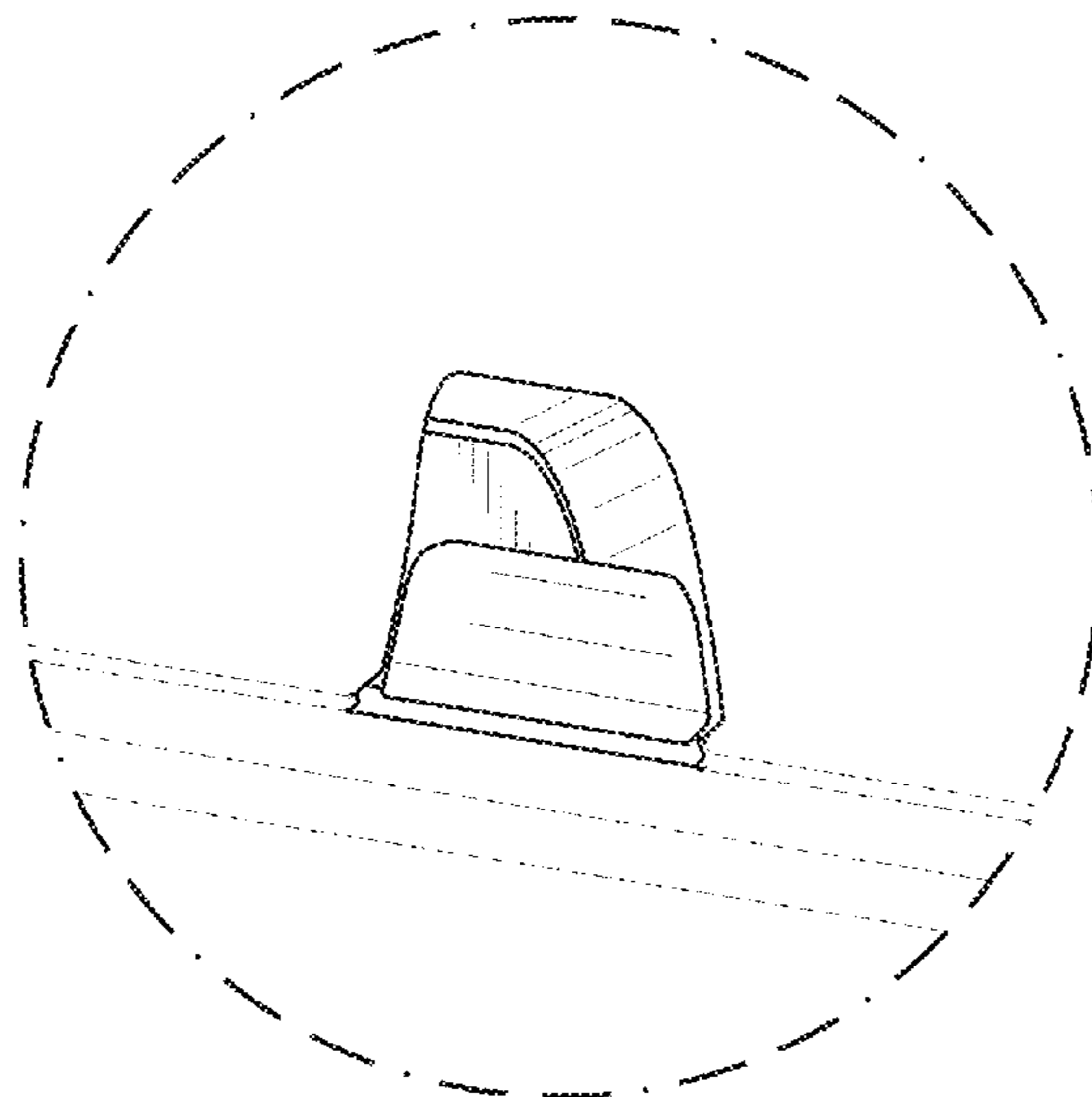

(56)

**References Cited**

U.S. PATENT DOCUMENTS

D483,649 S \* 12/2003 Linford et al. .... D8/339  
D494,447 S \* 8/2004 Linares ..... D8/330  
D519,824 S \* 5/2006 Collings et al. .... D8/331  
D529,785 S \* 10/2006 Xu ..... D8/337

7,261,342 B2 \* 8/2007 Smith ..... 292/332  
7,676,990 B2 \* 3/2010 Bestler et al. .... 49/449  
D635,436 S \* 4/2011 Barton ..... D8/331  
D638,276 S \* 5/2011 Tonizzo et al. .... D8/331  
D644,500 S \* 9/2011 Baldwin ..... D8/331  
D701,742 S \* 4/2014 Rechberg et al. .... D8/331

\* cited by examiner

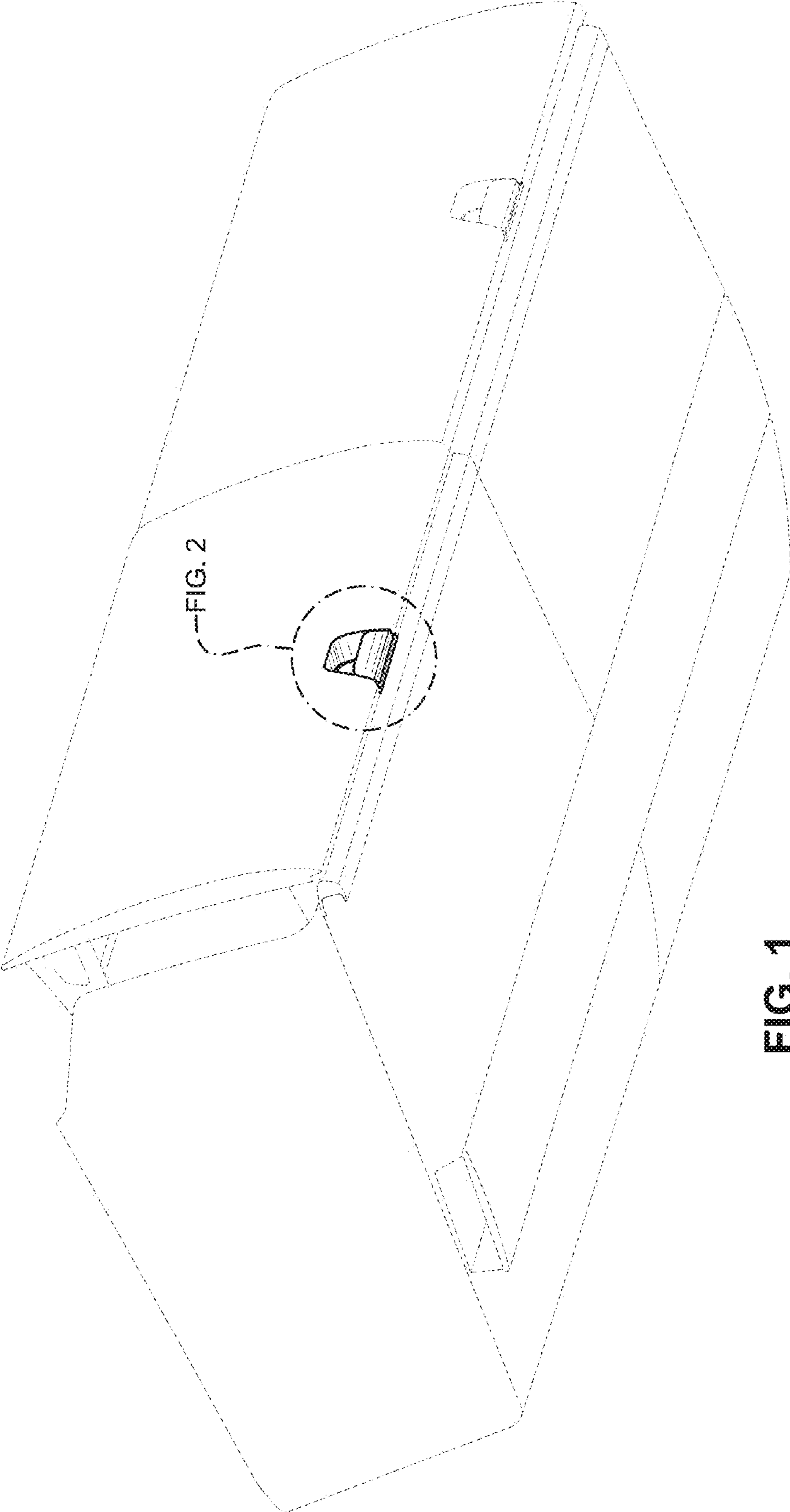

FIG. 1

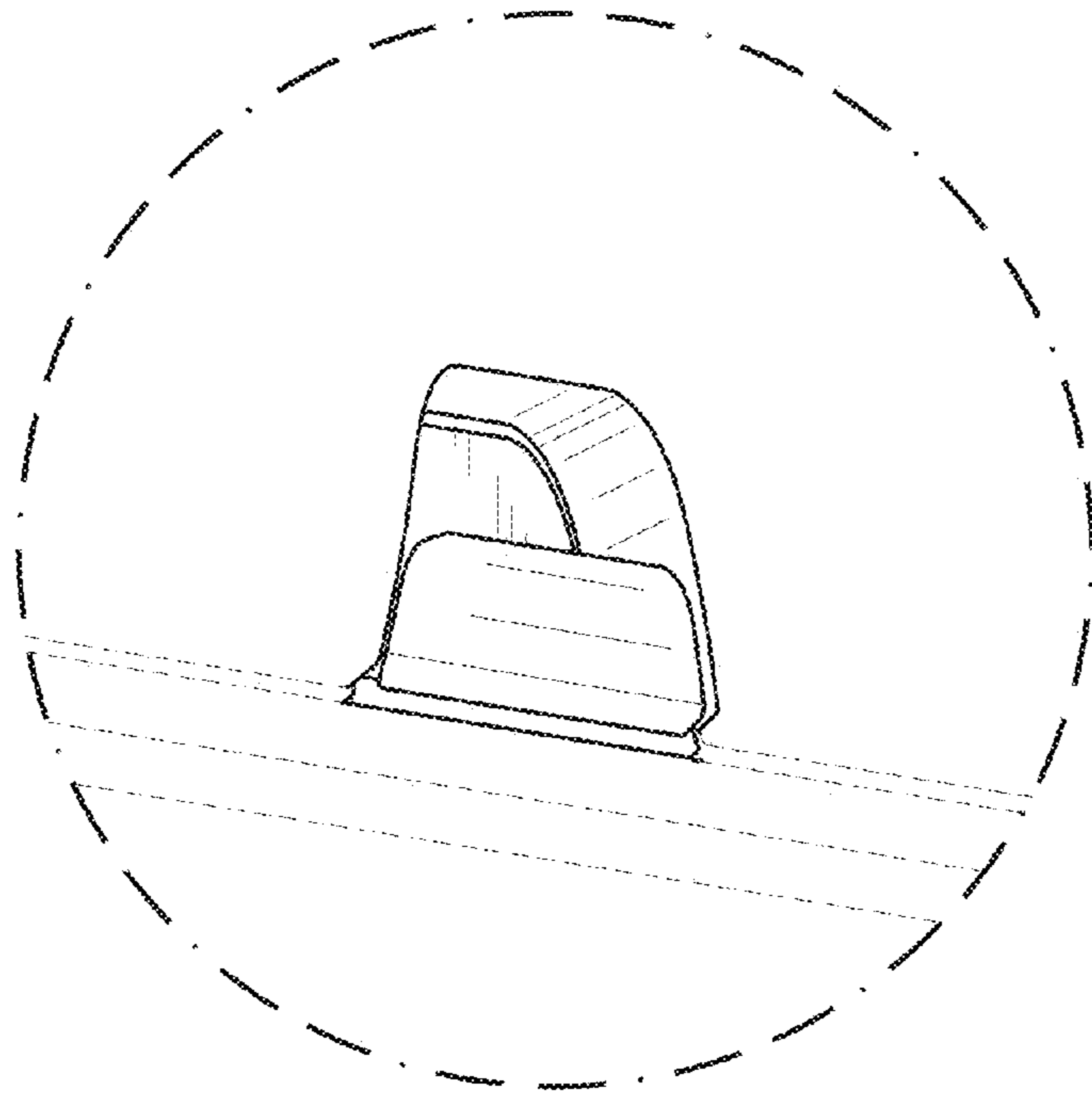

FIG. 2

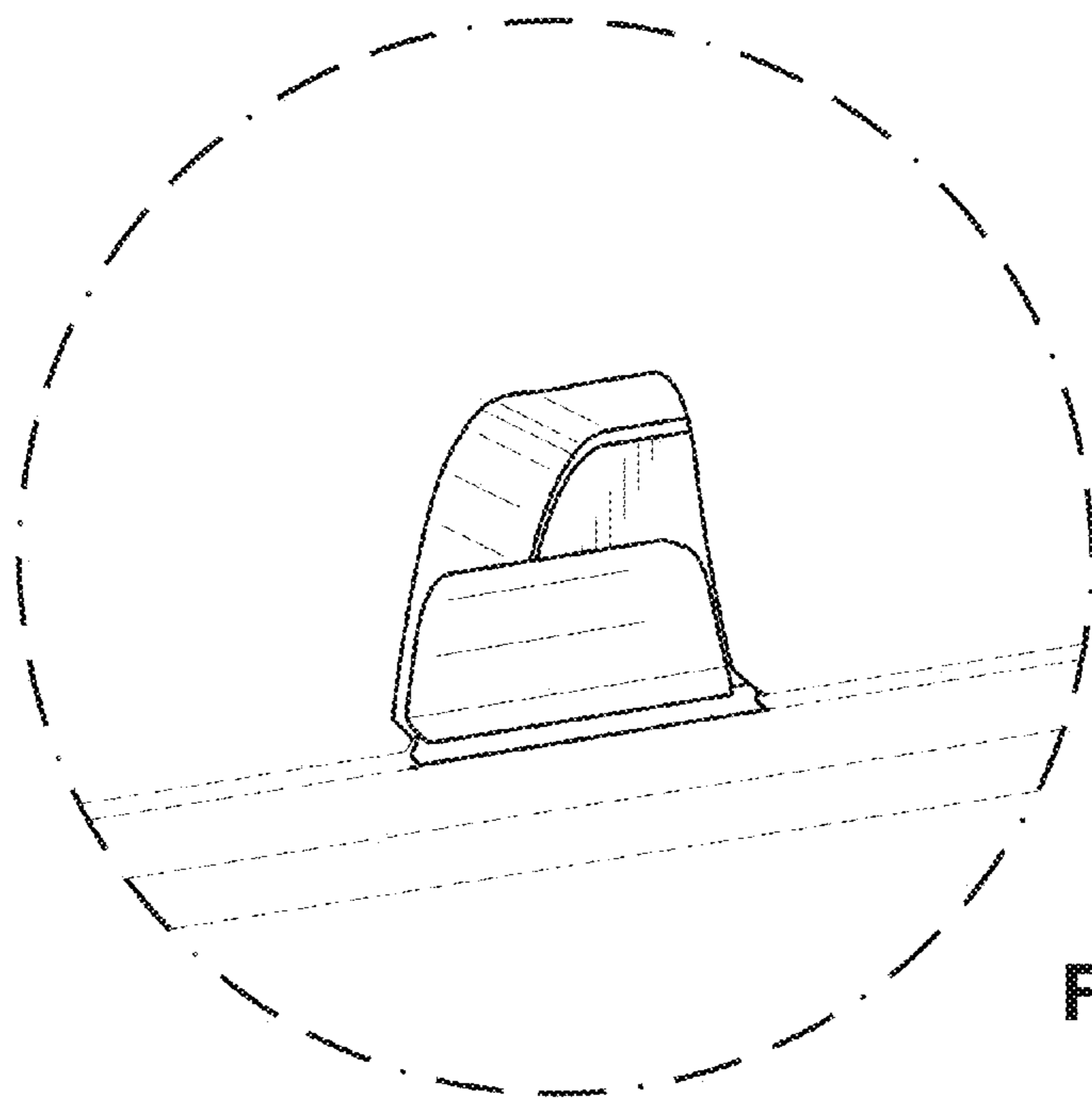

FIG. 3

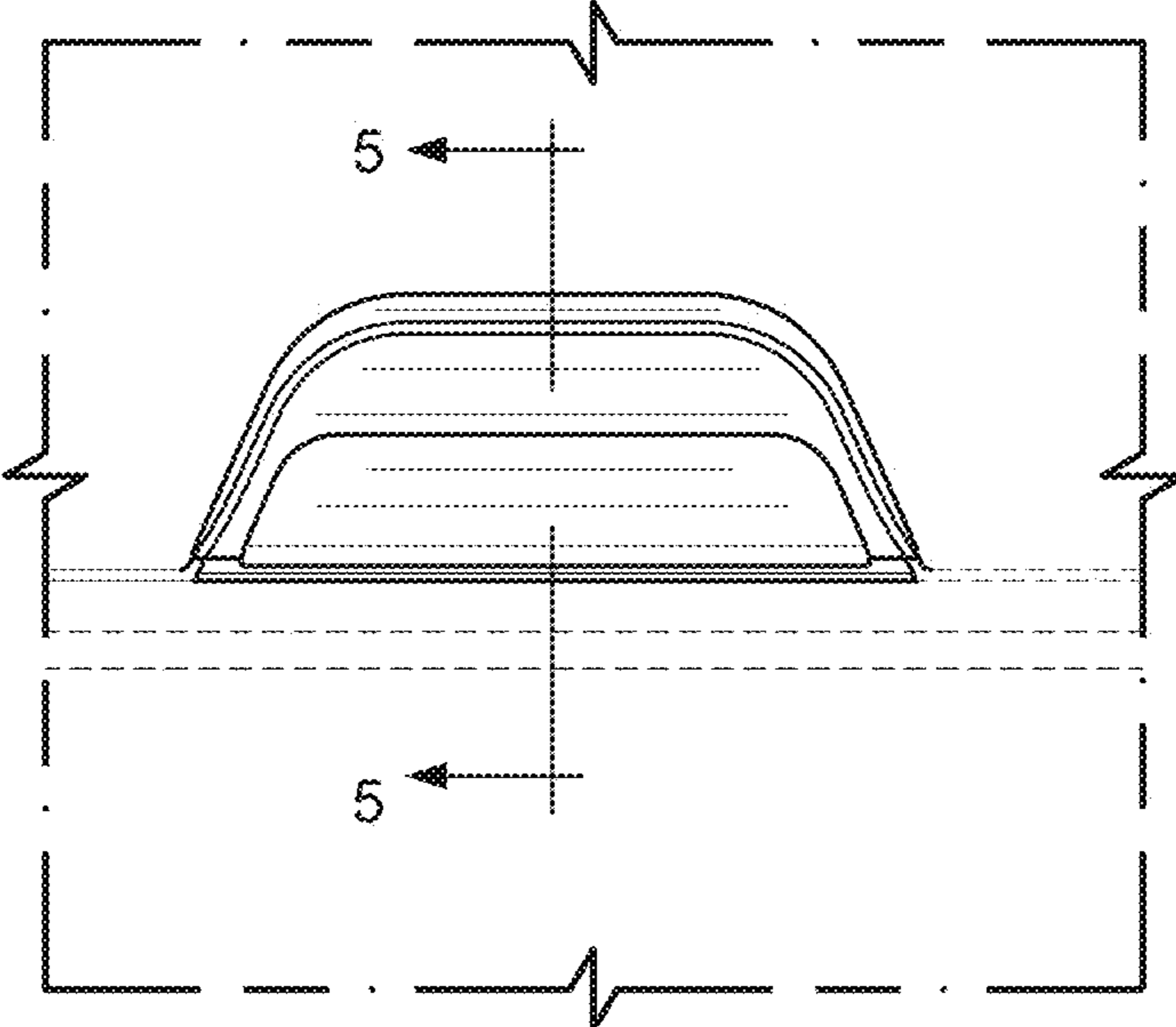

FIG. 4

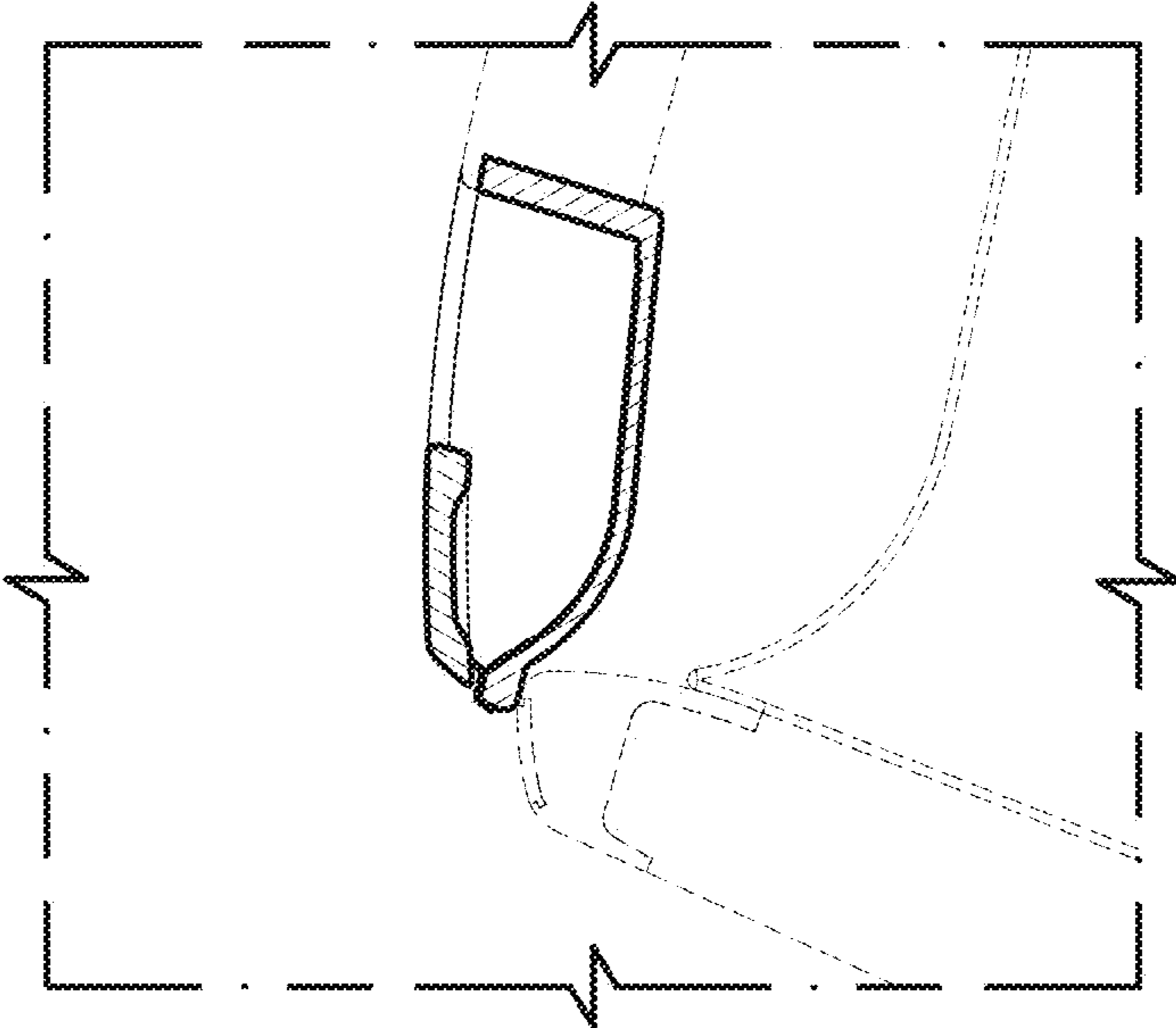

FIG. 5