



US00D718675S

(12) **United States Design Patent**
Sperling et al.

(10) **Patent No.:** **US D718,675 S**
(45) **Date of Patent:** **** Dec. 2, 2014**

(54) **REAR PORTION OF A MOTOR VEHICLE**

(71) Applicants: **Matthew Niven Sperling**, Huntington Beach, CA (US); **Chung Lee**, Ann Arbor, MI (US)

(72) Inventors: **Matthew Niven Sperling**, Huntington Beach, CA (US); **Chung Lee**, Ann Arbor, MI (US)

(73) Assignee: **Toyota Jidosha Kabushiki Kaisha**, Toyota-shi, Aichi-ken (JP)

(**) Term: **14 Years**

(21) Appl. No.: **29/458,682**

(22) Filed: **Jun. 21, 2013**

(30) **Foreign Application Priority Data**

Dec. 26, 2012 (JP) 2012-031512

(51) **LOC (10) Cl.** **12-16**

(52) **U.S. Cl.**
USPC **D12/164**

(58) **Field of Classification Search**
CPC B62D 33/00
USPC D12/86, 90-92, 98, 164; D21/533;
296/181.1, 181.5, 183.1, 37.6
See application file for complete search history.

(56) **References Cited**

U.S. PATENT DOCUMENTS

D600,601 S * 9/2009 Jung et al. D12/164
D607,783 S * 1/2010 Roller et al. D12/98
D646,206 S * 10/2011 Sato et al. D12/98
D703,586 S * 4/2014 Platto et al. D12/98

OTHER PUBLICATIONS

Netcarshow.com; URL: <http://www.netcarshow.com>; Mfg.: Ford; Model: Ford F-150; available on at least Jun. 13, 2012.

Netcarshow.com; URL: http://www.netcarshow.com/dodge/2009-ram_1500/; Mfg.: Dodge; Model: Dodge Ram 1500 (2009); available on at least Jun. 13, 2012.

* cited by examiner

Primary Examiner — Melody N Brown

(74) *Attorney, Agent, or Firm* — Finnegan, Henderson, Farabow, Garrett & Dunner, LLP

(57) **CLAIM**

The ornamental design for a rear portion of a motor vehicle, as shown and described.

DESCRIPTION

FIG. 1 is a right front perspective view of a rear portion of a motor vehicle showing our new design; FIG. 2 is a right rear perspective view thereof; FIG. 3 is a right side view thereof, the left side being a mirror image thereof; FIG. 4 is a front view thereof; FIG. 5 is a rear view thereof; and, FIG. 6 is a top plan view thereof. The bottom view of the motor vehicle forms no part of the claimed design. The bottom view of the motor vehicle forms no part of the claimed design. The deemphasized and halftone portions shown in the drawings illustrate environmental structure for the rear portion of a motor vehicle that forms no part of the claimed design.

1 Claim, 3 Drawing Sheets

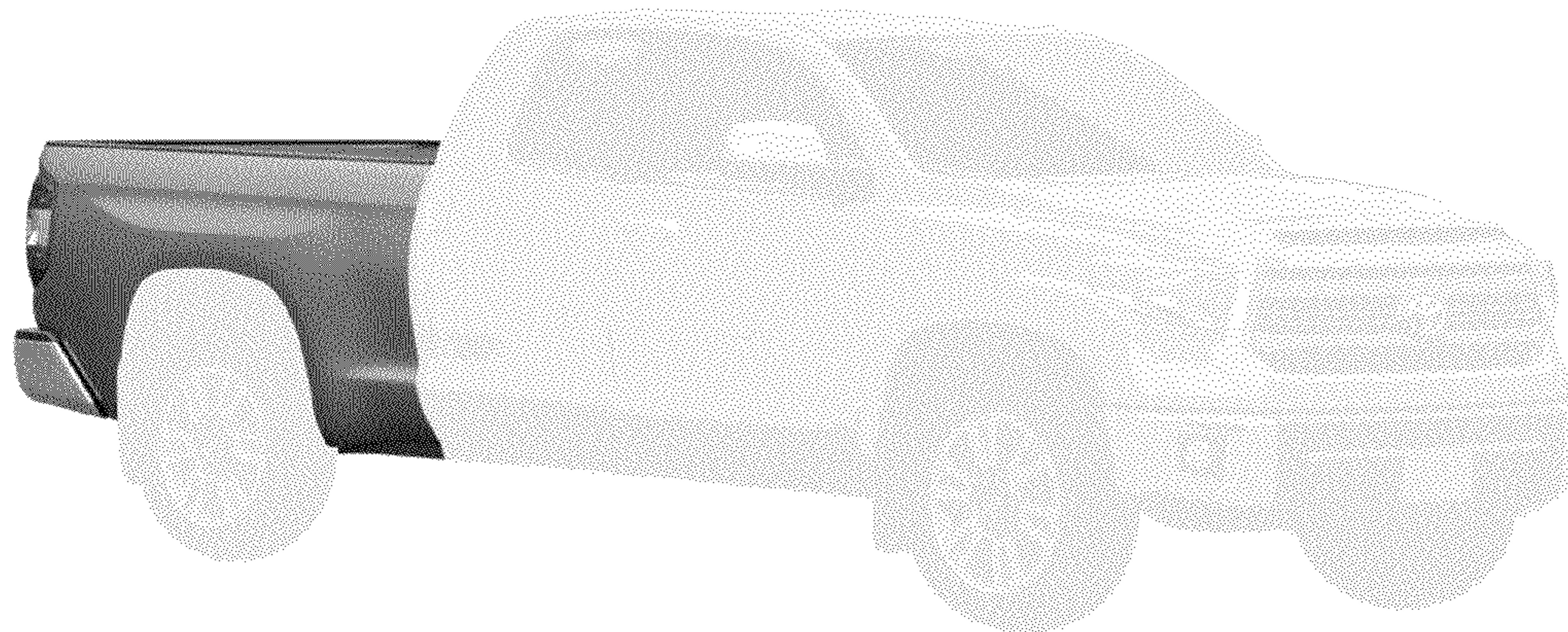

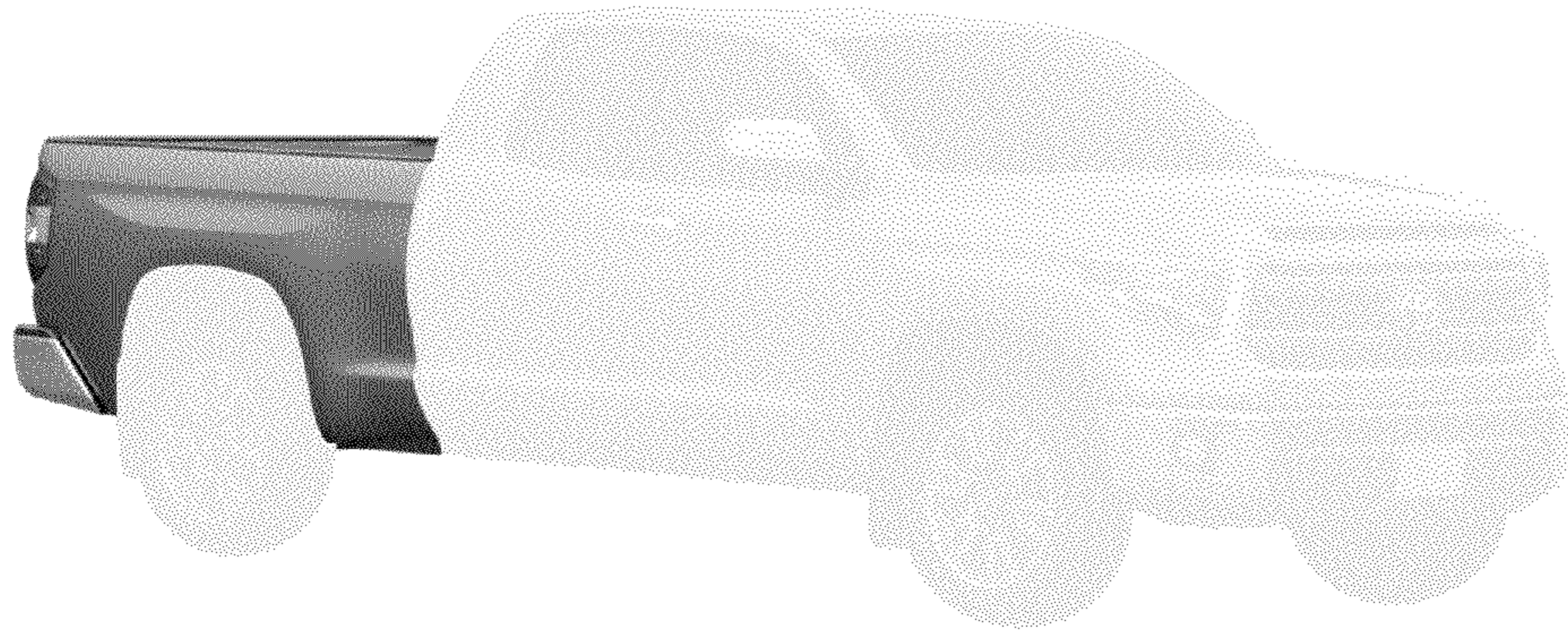

FIG. 1

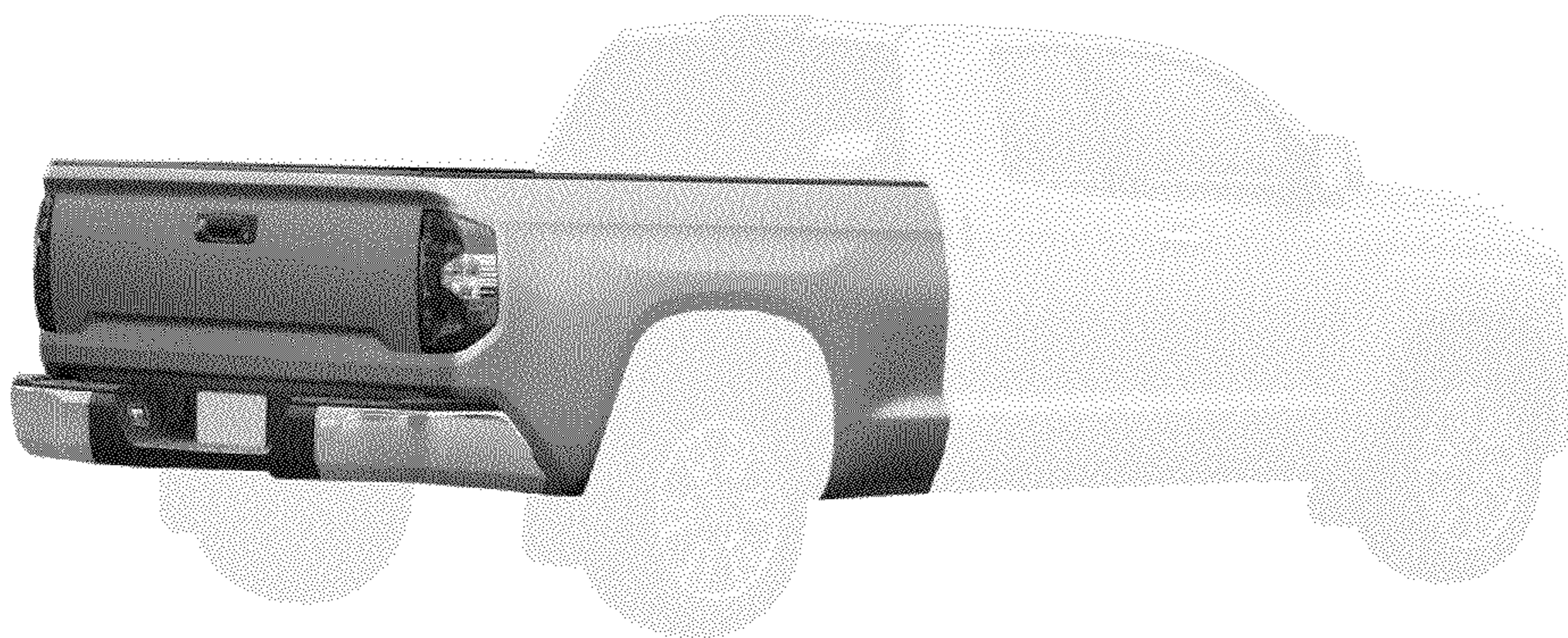

FIG. 2

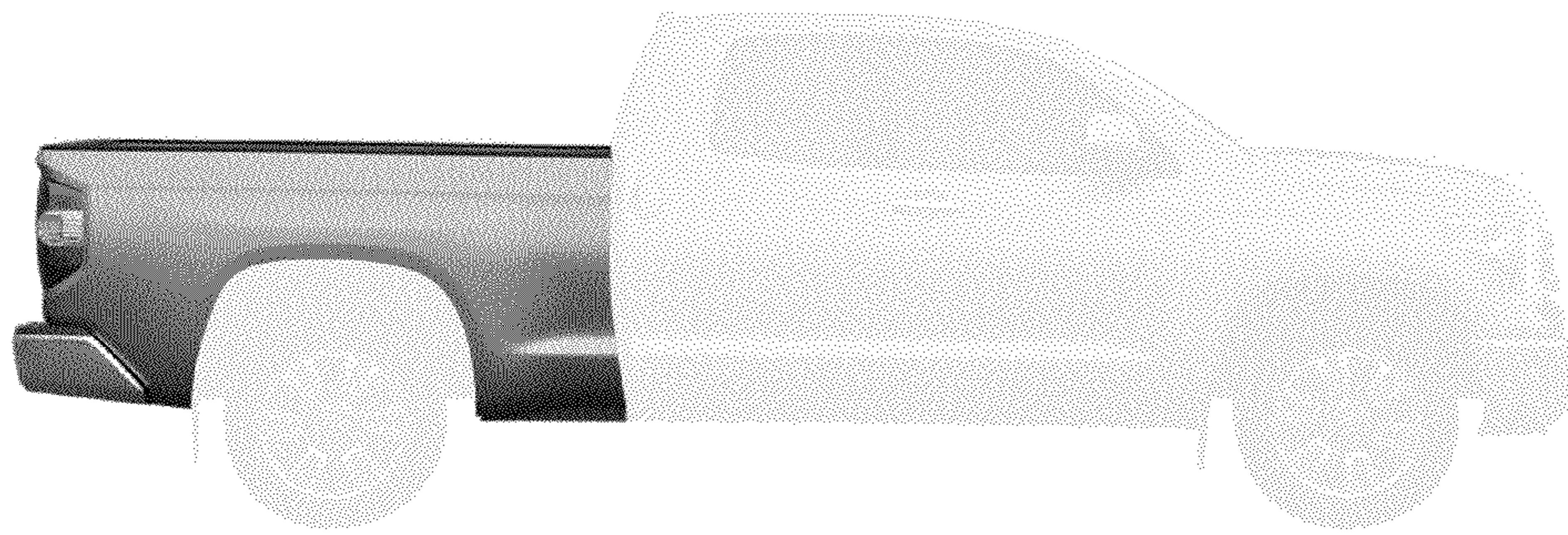

FIG. 3



FIG. 4

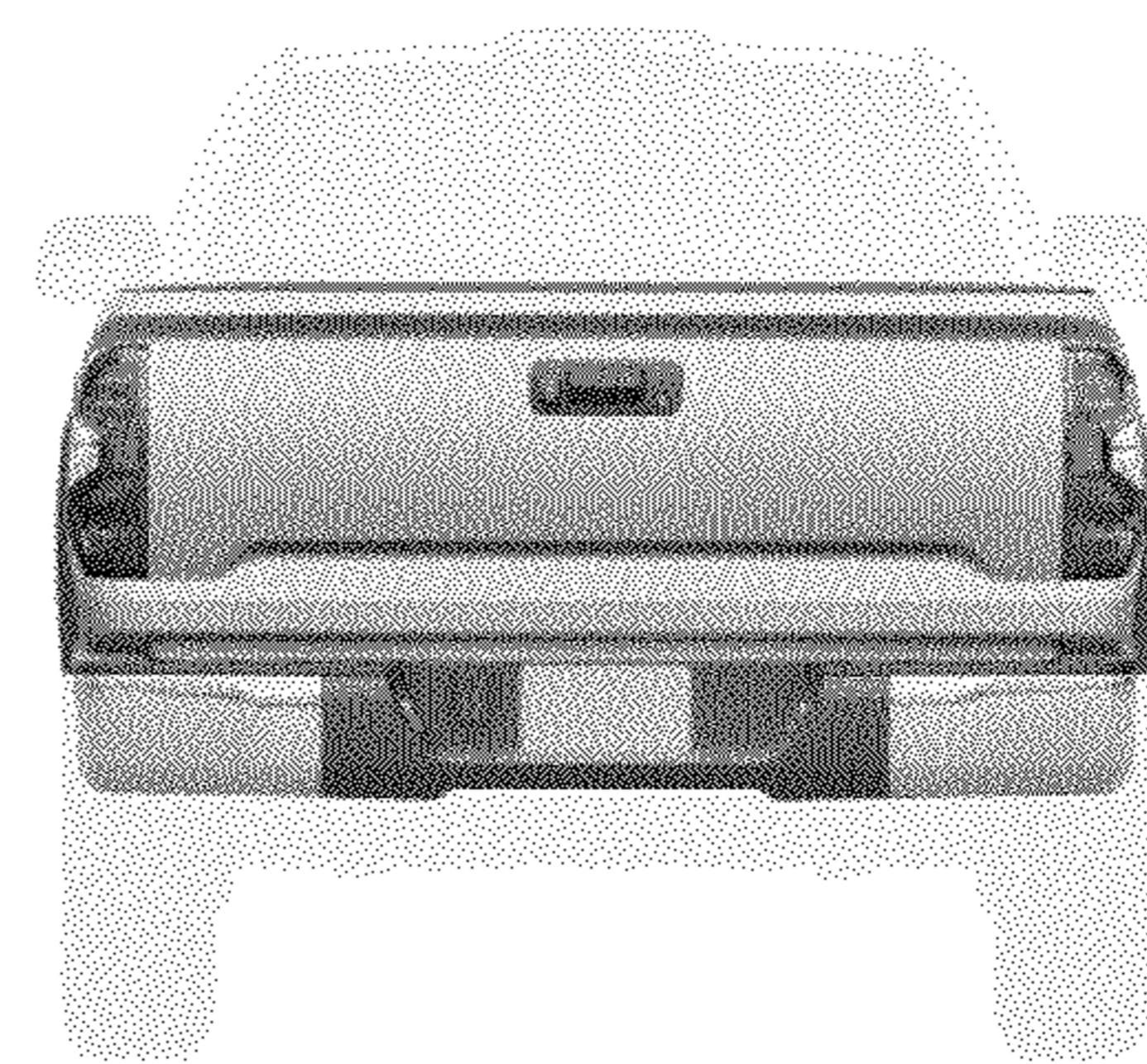

FIG. 5

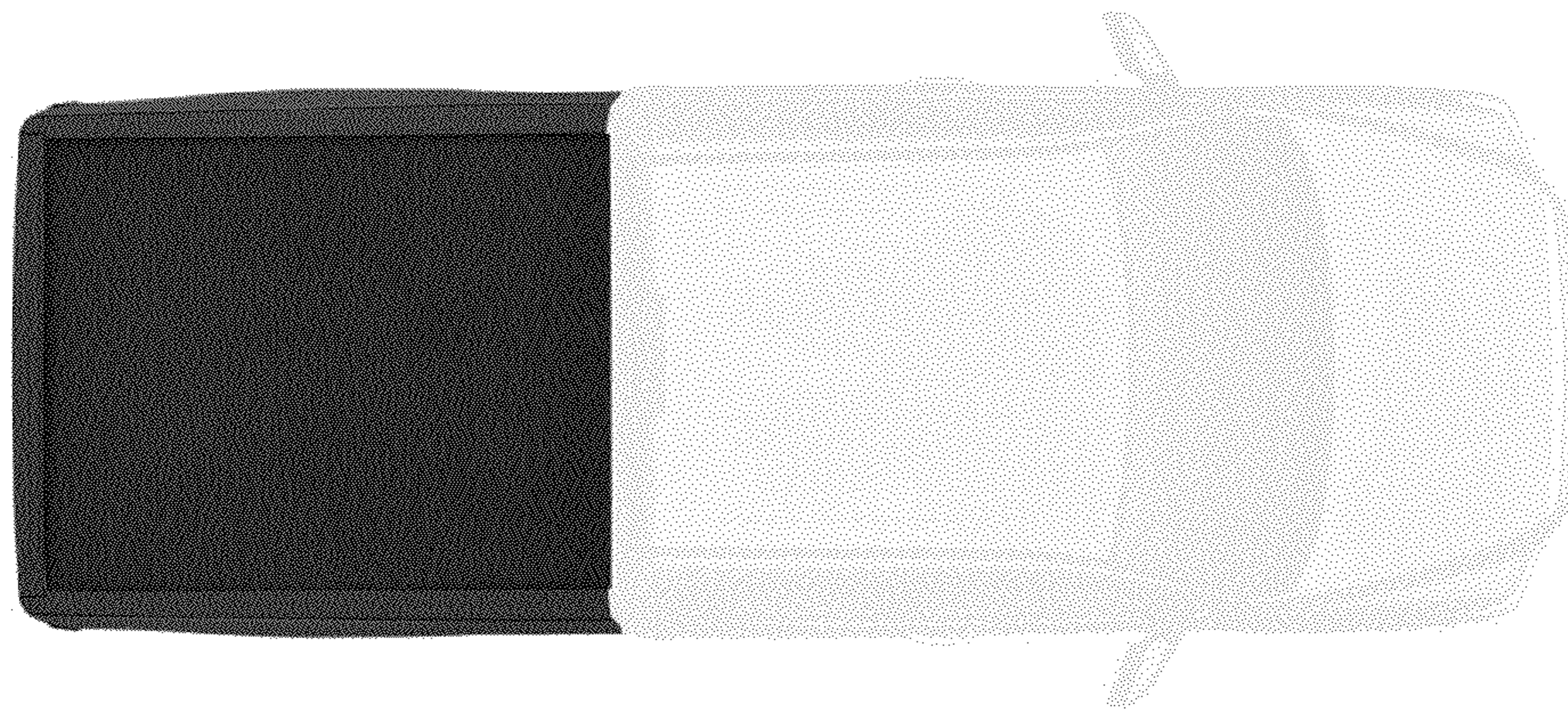

FIG. 6

UNITED STATES PATENT AND TRADEMARK OFFICE
CERTIFICATE OF CORRECTION

PATENT NO. : D718,675 S
APPLICATION NO. : 29/458682
DATED : December 2, 2014
INVENTOR(S) : Matthew Niven Sperling et al.

Page 1 of 1

It is certified that error appears in the above-identified patent and that said Letters Patent is hereby corrected as shown below:

On the Title Page

Please correct item (57) under DESCRIPTION, last paragraph, of the above-identified patent, as follows:

The bottom view of the motor vehicle forms no part of the claimed design. The de-emphasized and halftone portions shown in the drawings illustrate environmental structure for the rear portion of a motor vehicle that forms no part of the claimed design.

Signed and Sealed this
Seventh Day of April, 2015



Michelle K. Lee
Director of the United States Patent and Trademark Office