



US00D718669S

(12) **United States Design Patent**
Kiska

(10) **Patent No.:** **US D718,669 S**
(45) **Date of Patent:** **** Dec. 2, 2014**

(54) **MOTORCYCLE**

- (71) Applicant: **KTM-Sportmotorcycle AG**,
Anif-Salzburg (AT)
- (72) Inventor: **Gerald Kiska**, Salzburg (AT)
- (73) Assignee: **KTM-Sportmotorcycle AG** (AT)
- (**) Term: **14 Years**
- (21) Appl. No.: **29/480,577**
- (22) Filed: **Jan. 28, 2014**

(30) **Foreign Application Priority Data**

Aug. 19, 2013 (AT) MU 554-2013

(51) **LOC (10) Cl.** **12-11**

(52) **U.S. Cl.**
USPC **D12/110**

(58) **Field of Classification Search**

CPC B62D 37/00; B62D 57/00; B62K 9/00;
B62K 11/04; B62K 17/00; B62K 19/48;
B62M 7/12; F02B 61/02; A63H 17/21;
B62J 17/00; B62J 17/04; B62J 29/00

USPC D12/109, 110, 111, 114, 117, 126, 184,
D12/186; D21/432, 458, 538; 180/210–217,
180/219, 220, 225, 229, 908; 280/103, 124,
280/152.1–152.3, 288.2, 288.4, 304.3, 770,
280/827, 828, 847, 848; 296/77.1, 78.1,
296/181.1, 187.01, 187.12, 192, 193.01,
296/193.04, 193.05, 193.09; 446/440

See application file for complete search history.

(56) **References Cited**

U.S. PATENT DOCUMENTS

D504,844 S * 5/2005 Sasanami D12/110
6,998,970 B2 * 2/2006 Conte 340/432
D551,129 S * 9/2007 Takeda D12/110
D567,717 S * 4/2008 Hishiki D12/110

(Continued)

OTHER PUBLICATIONS

Allen, Jeff. "Characters: KTM 1290 Super Duke R—A velociraptor in wolf's clothing." Cycle World., Apr. 30, 2014 [online], [retrieved on Jun. 10, 2014]. Retrieved from the Internet <URL: <http://www.cycleworld.com/2014/04/30/motorcycles-with-character-ktm-1290-super-duke-r-naked-bike/>>.*

(Continued)

Primary Examiner — Philip S Hyder

Assistant Examiner — Darlington Ly

(74) *Attorney, Agent, or Firm* — Renner, Otto, Boisselle & Sklar, LLP

(57) **CLAIM**

The ornamental design for a motorcycle, as shown and described.

DESCRIPTION

The patent or application file contains at least one drawing executed in color. Copies of this patent or patent application publication with color drawing(s) will be provided by the Office upon request and payment of the necessary fee.

FIG. 1 is a front view of a motorcycle showing my new design;

FIG. 2 is a rear view thereof;

FIG. 3 is a top view thereof;

FIG. 4 is a right side view thereof;

FIG. 5 is a left side view thereof;

FIG. 6 is a front right perspective view thereof;

FIG. 7 is a front left perspective view thereof;

FIG. 8 is a rear right perspective view thereof; and,

FIG. 9 is a rear left perspective view thereof.

The broken lines enclosing the white surfaces illustrate portions of the motorcycle that form no part of the claimed design.

The bottom of the motorcycle forms no part of the claimed design.

1 Claim, 5 Drawing Sheets
(5 of 5 Drawing Sheet(s) Filed in Color)

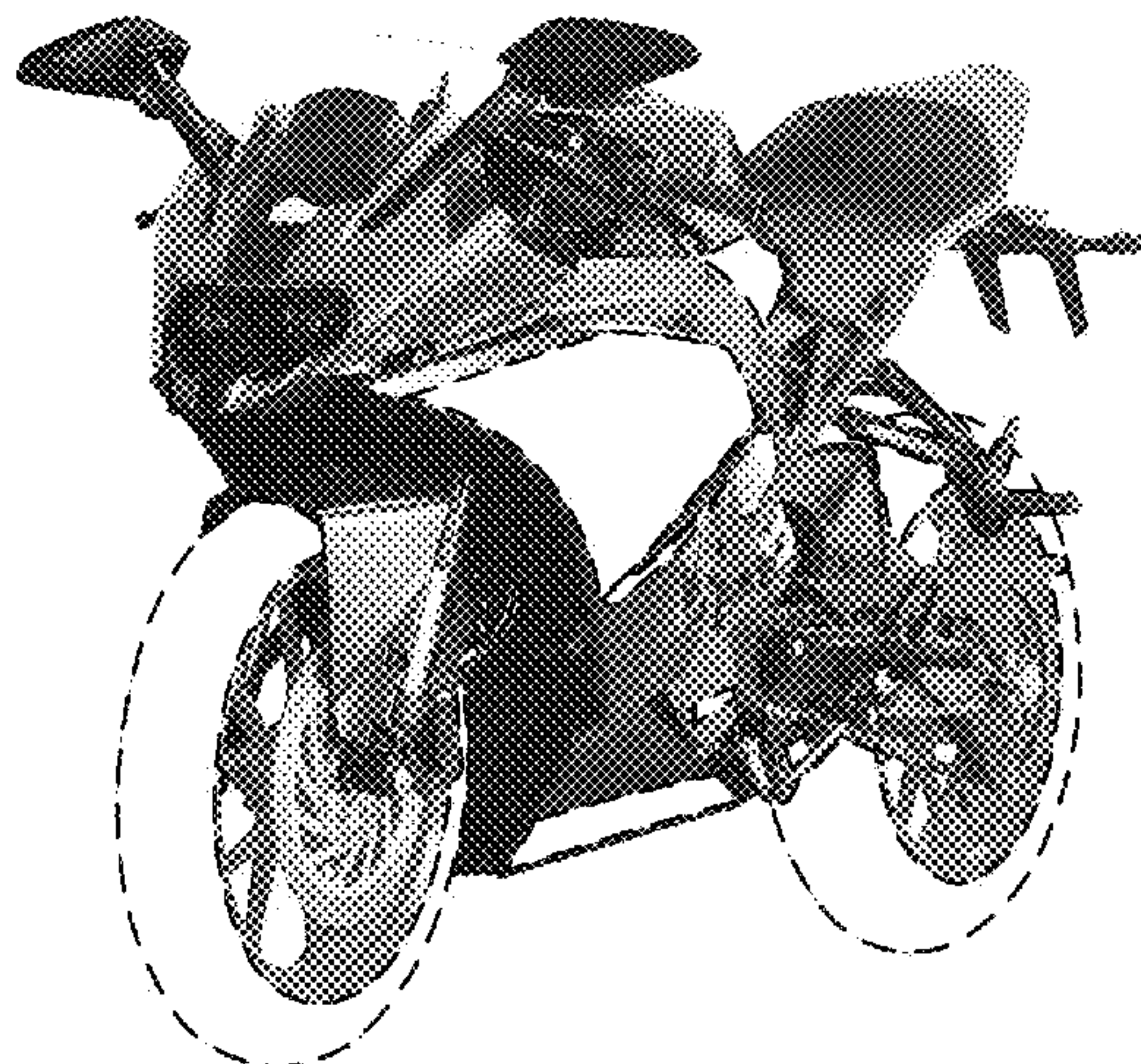

(56)

References Cited

OTHER PUBLICATIONS

U.S. PATENT DOCUMENTS

D588,961 S * 3/2009 Tanaka et al. D12/110
D597,449 S * 8/2009 Nagao D12/110
D598,815 S * 8/2009 Nagao D12/110
D601,458 S * 10/2009 Nagao D12/110
D605,089 S * 12/2009 Tanaka et al. D12/110
D638,756 S * 5/2011 Kouchi et al. D12/110
D669,397 S * 10/2012 Isokari D12/110
2008/0169134 A1 * 7/2008 Tomolillo et al. 180/6.24
2010/0025140 A1 * 2/2010 Takenaka et al. 180/219

“2012 BMW HP2 Sport Review.” Motorcycles Specification., Feb.
14, 2012 [online], [retrieved on Jun. 10, 2014]. Retrieved from the
Internet <URL: [http://motorcyclespecification.blogspot.com/2012/
03/2012-bmw-hp2-sport-review.html](http://motorcyclespecification.blogspot.com/2012/03/2012-bmw-hp2-sport-review.html)>.*

* cited by examiner

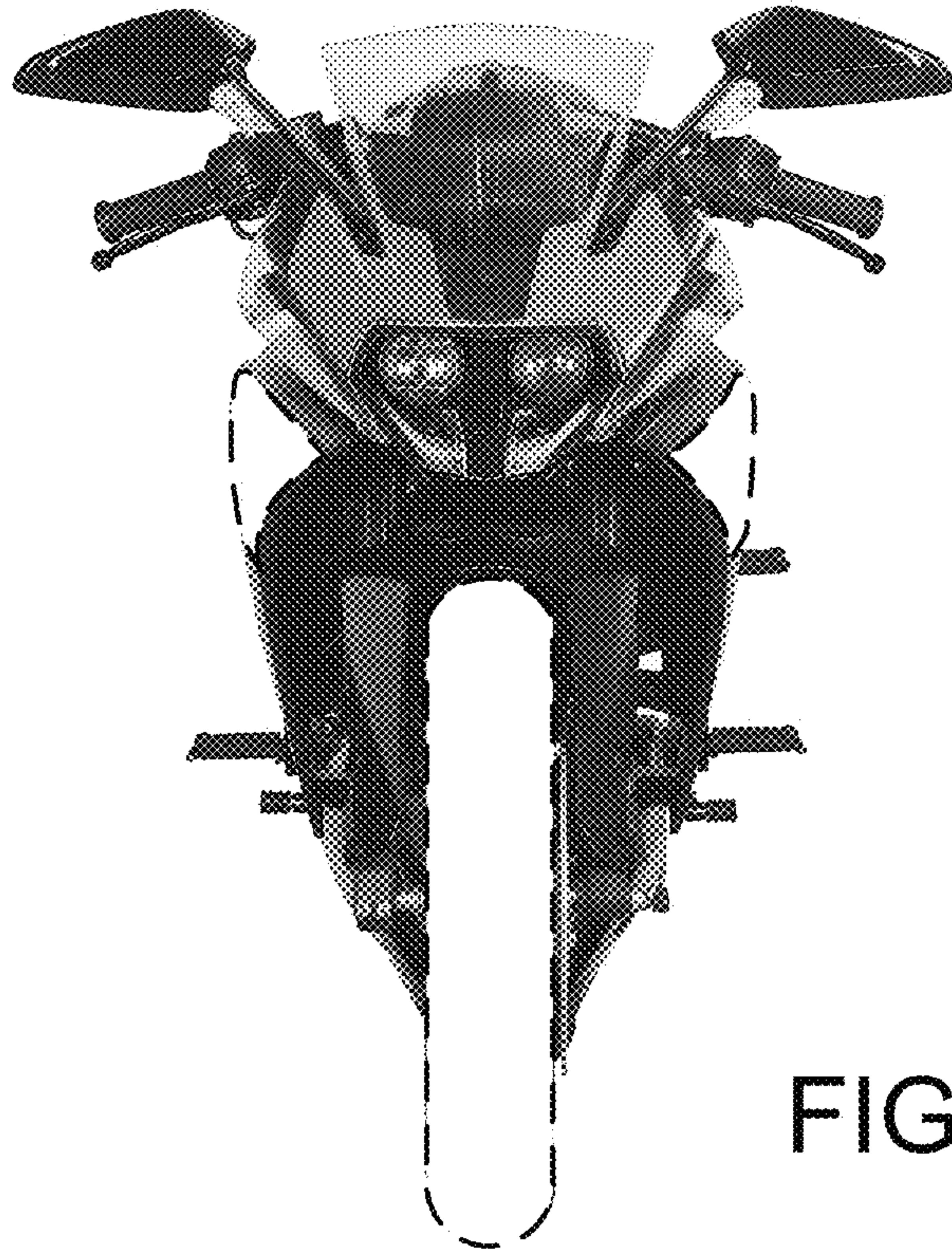

FIG. 1

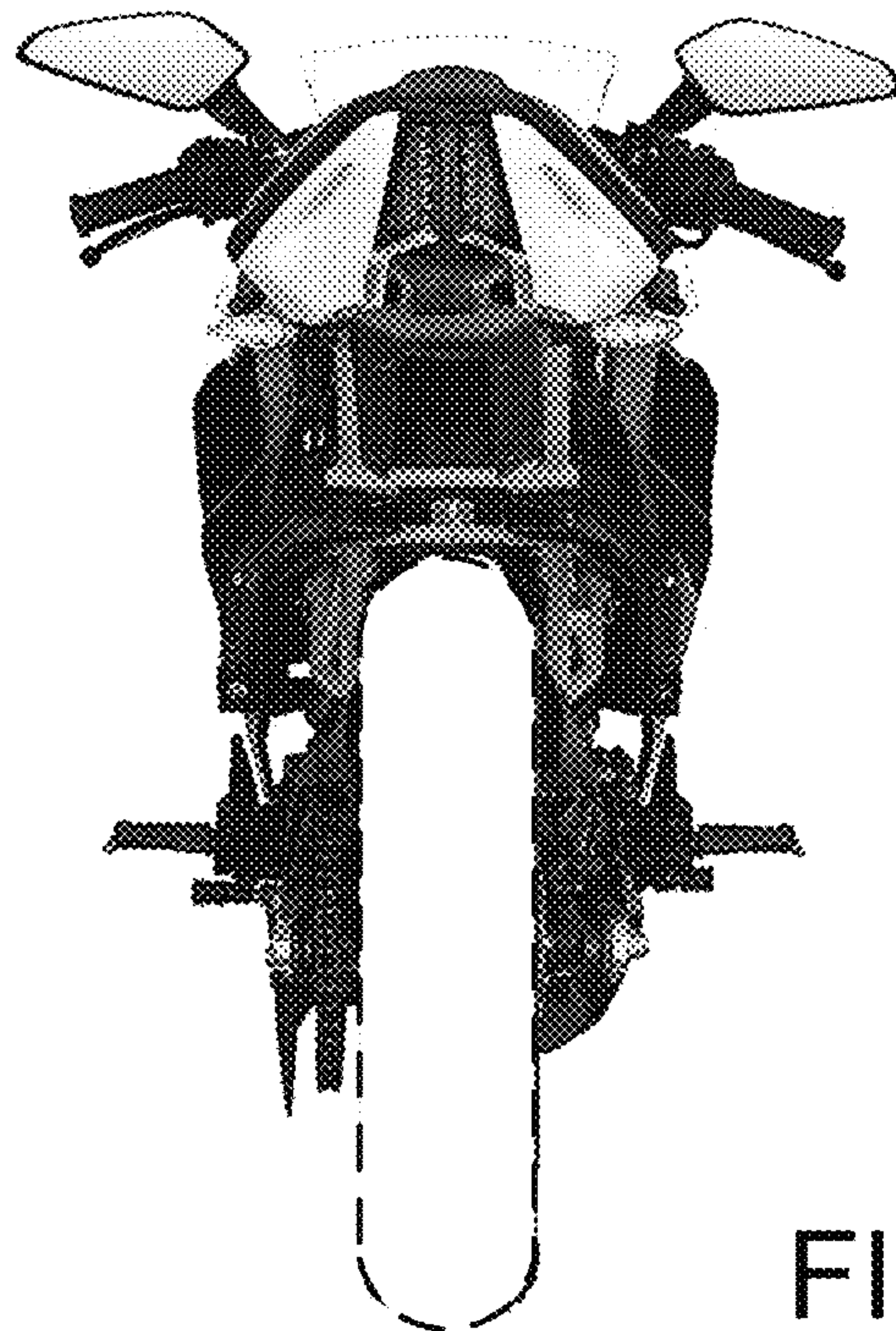

FIG. 2

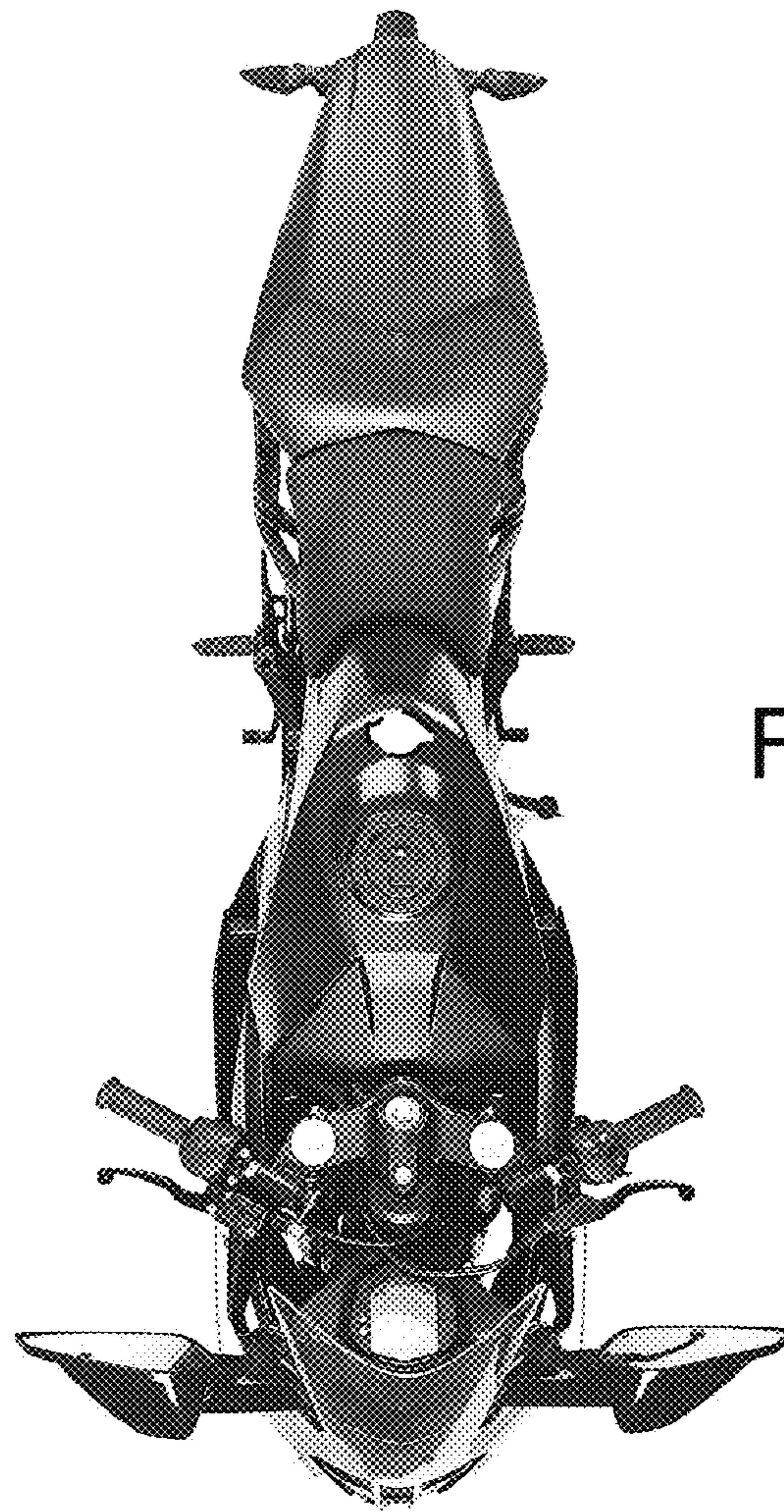

FIG. 3

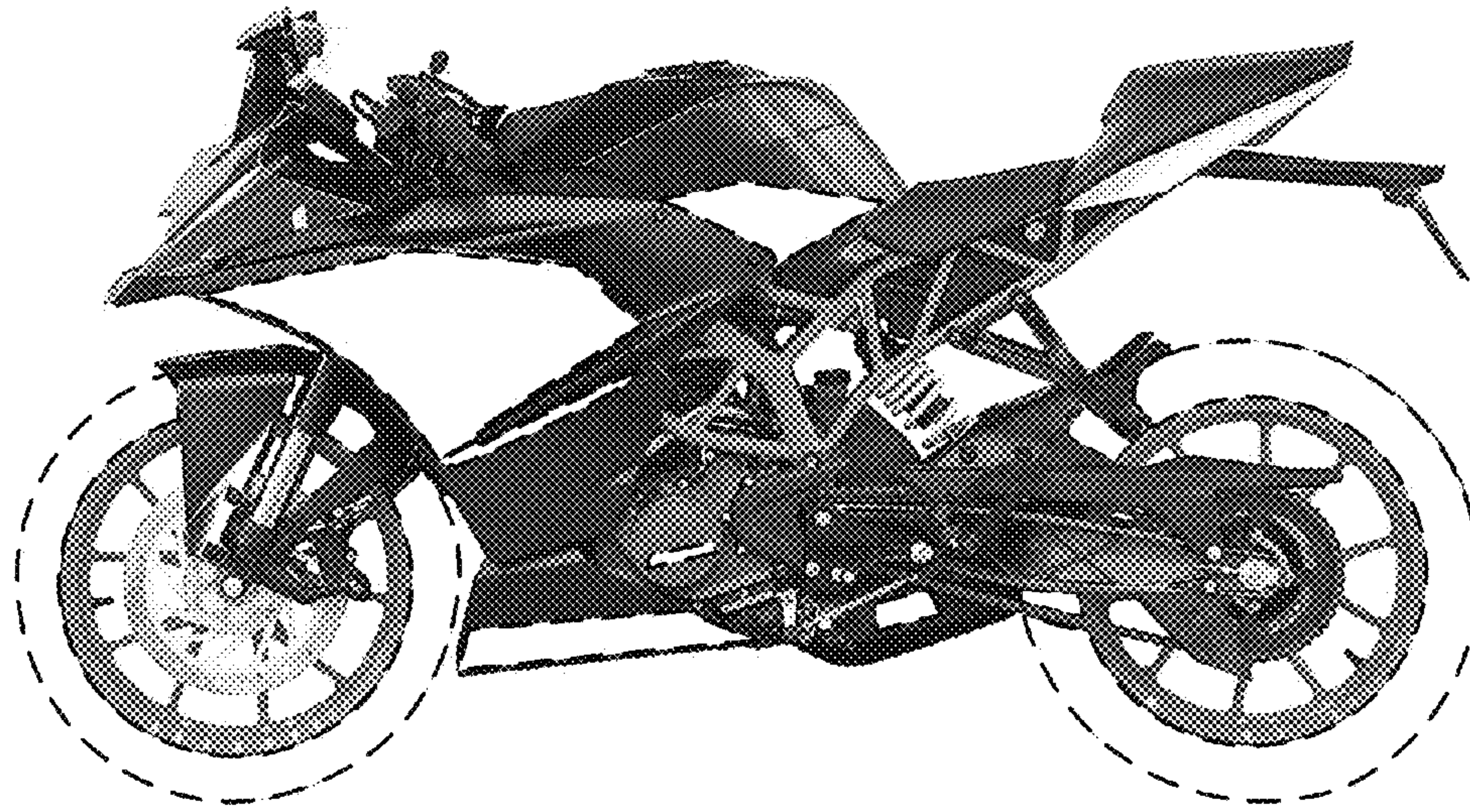

FIG. 4

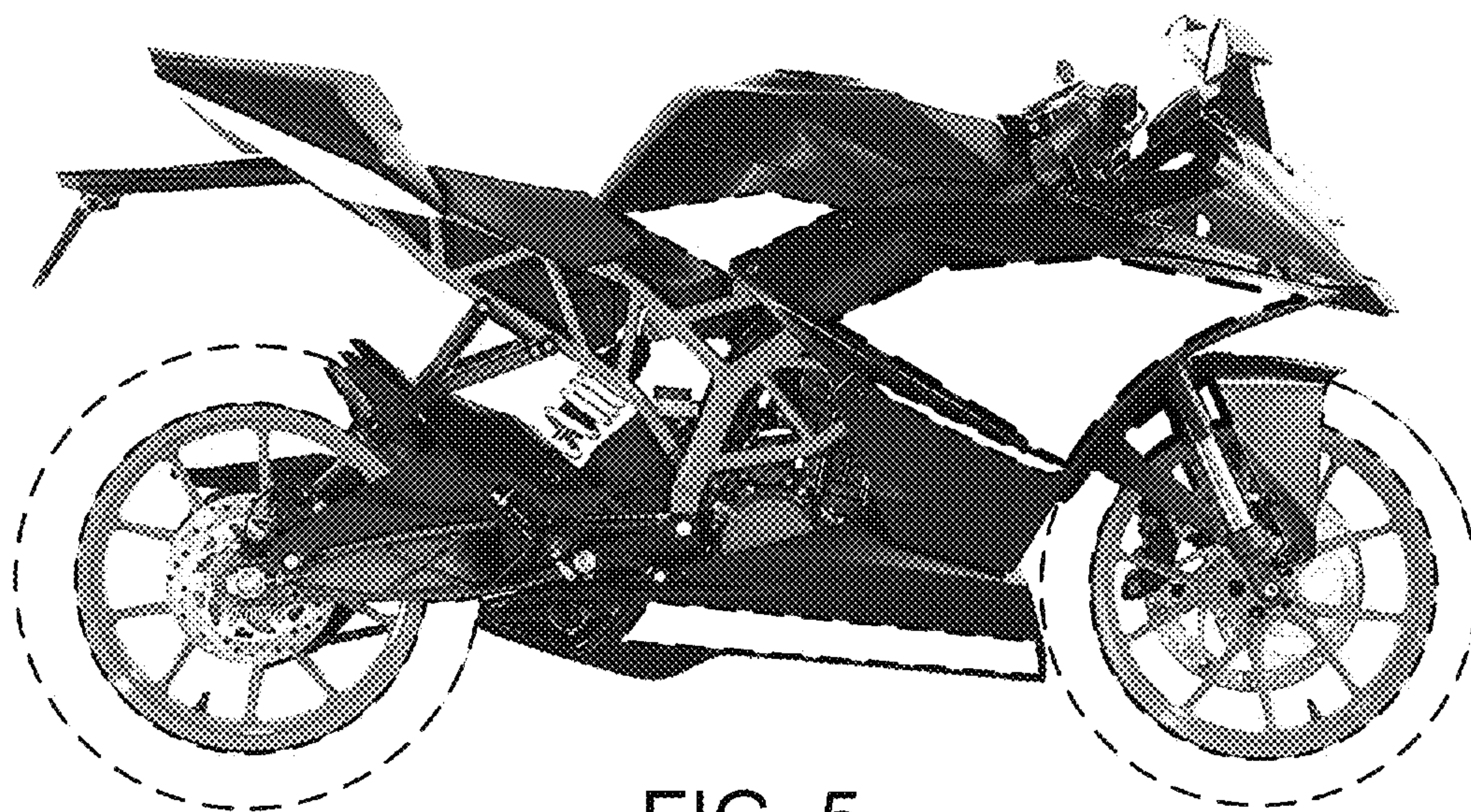

FIG. 5

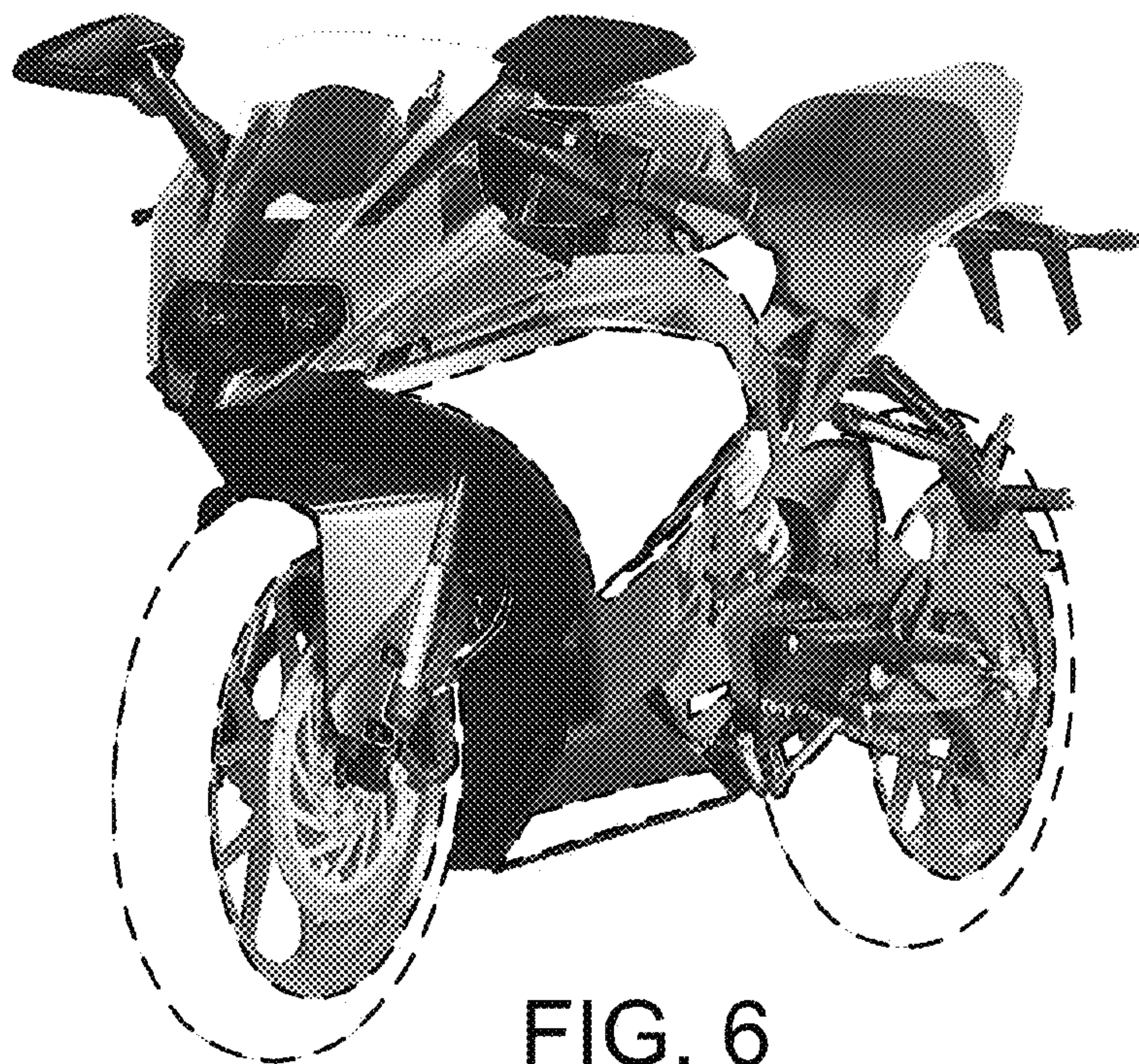

FIG. 6

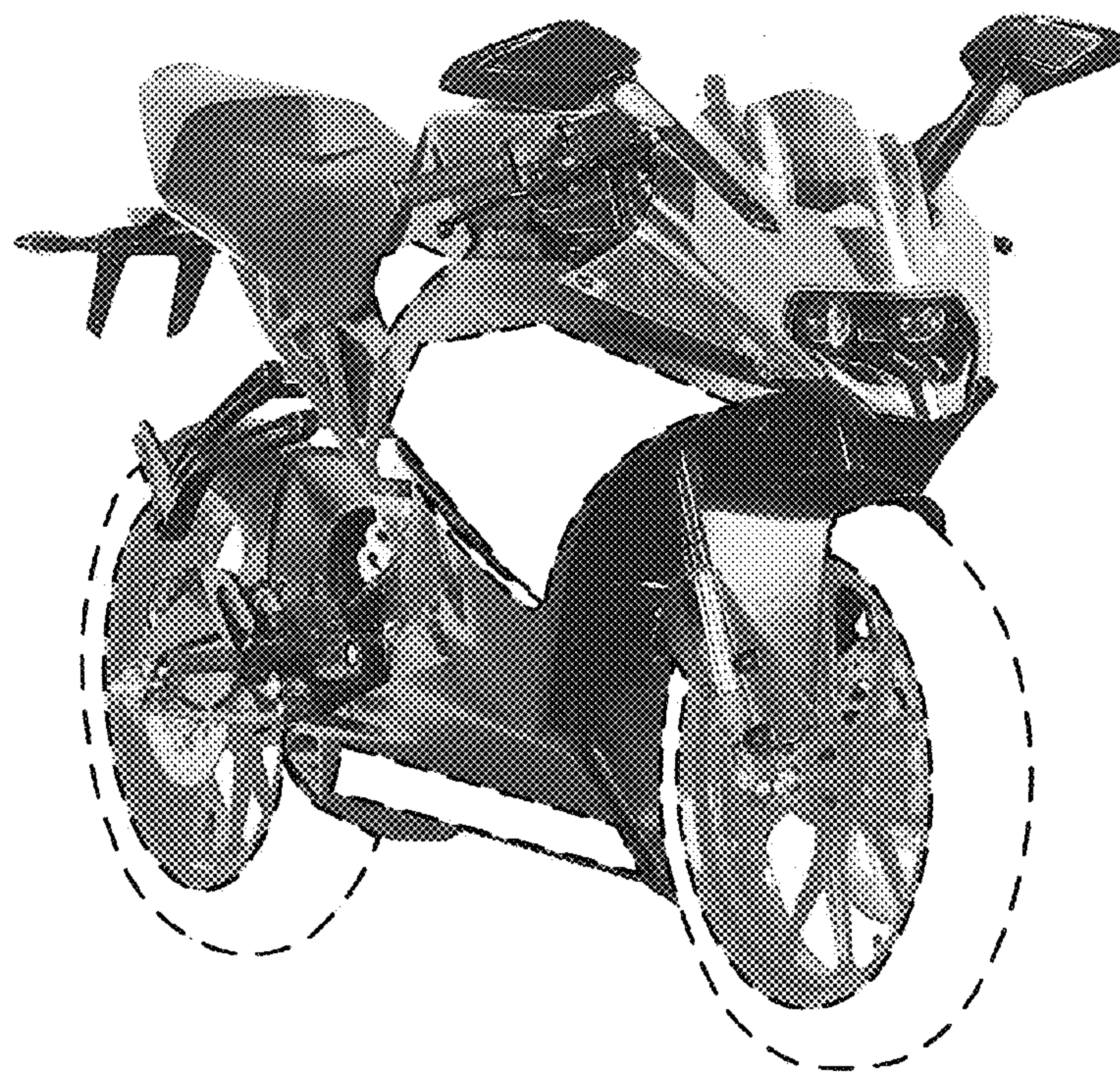

FIG. 7

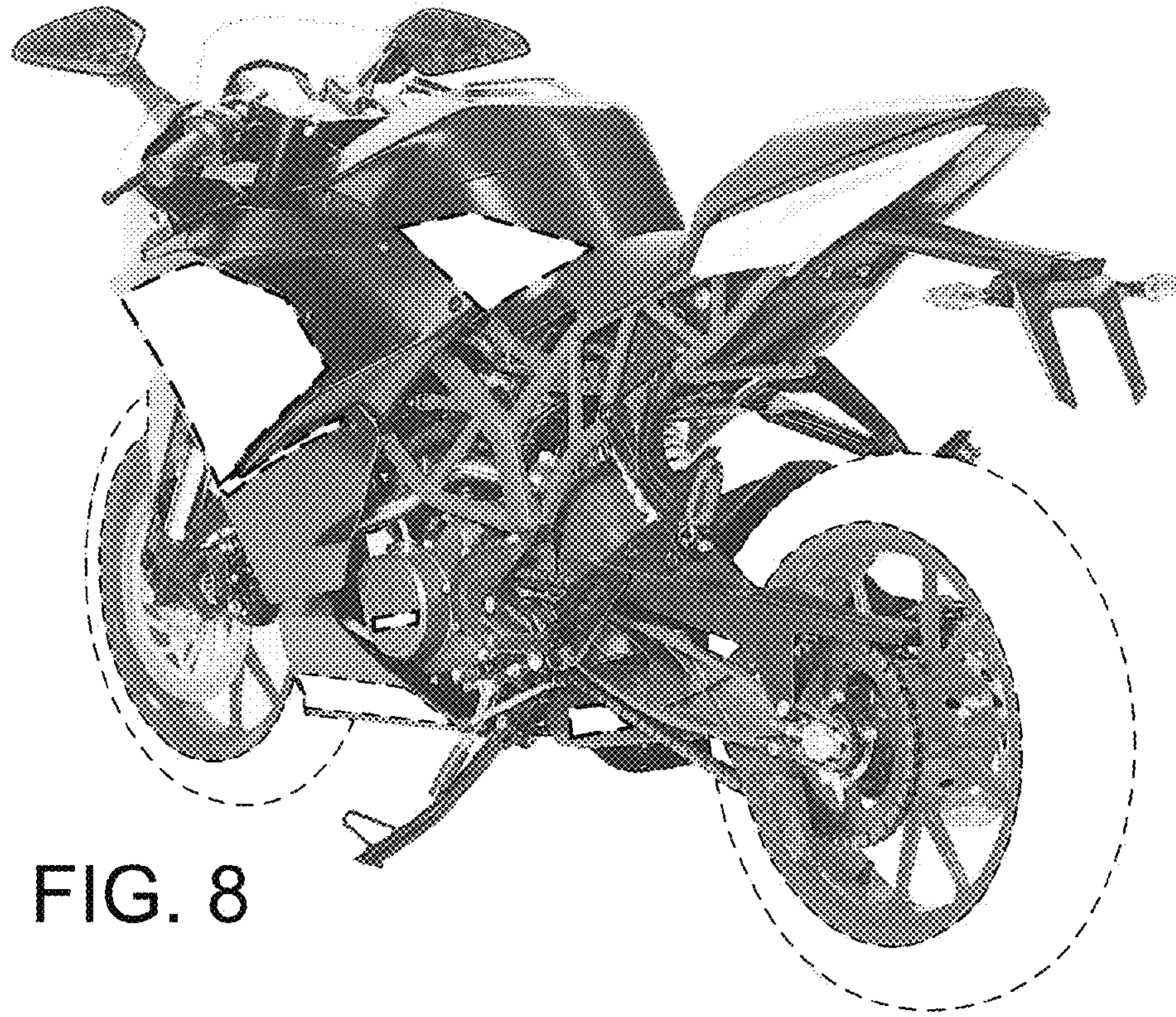

FIG. 8

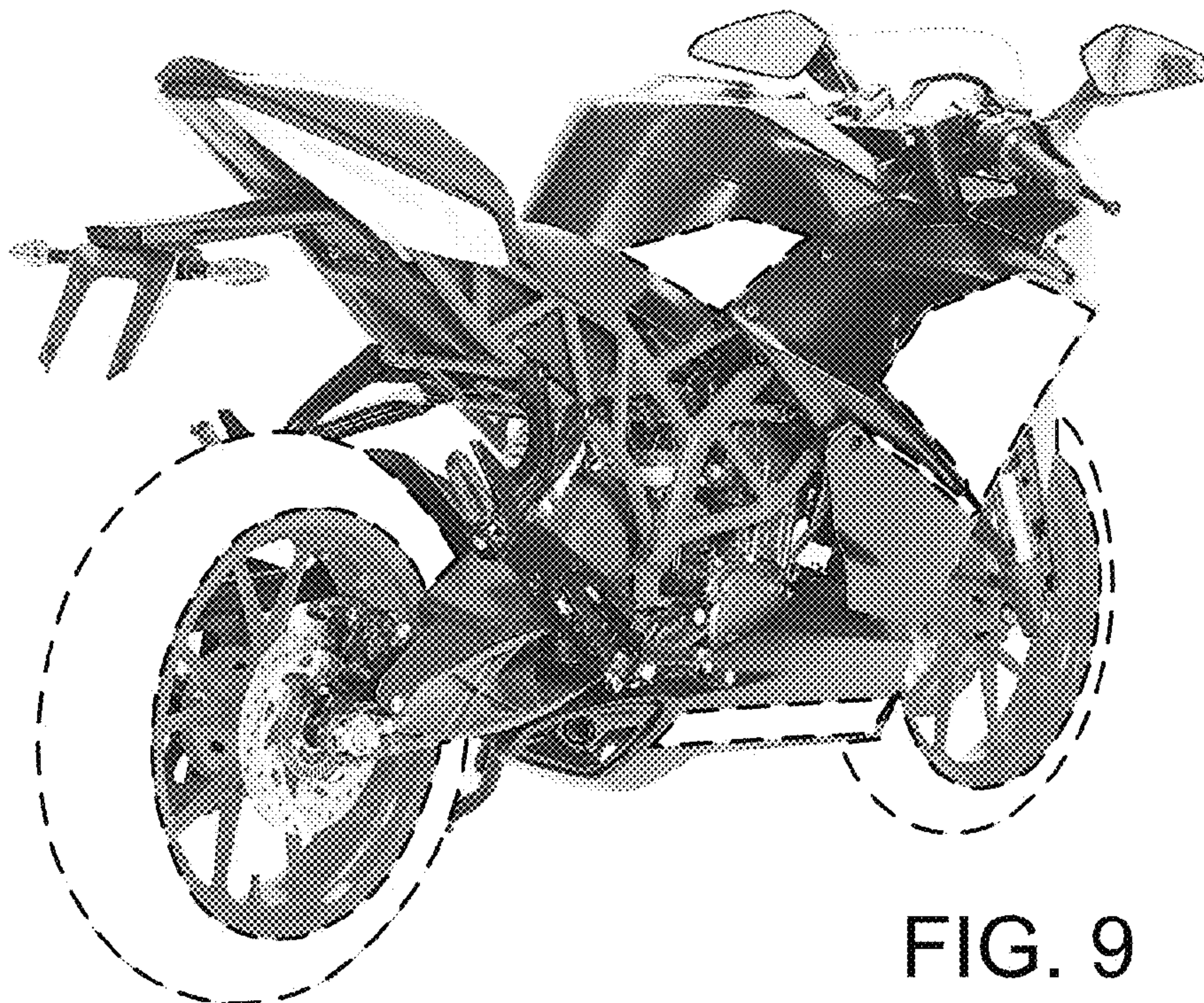

FIG. 9