



US00D718659S

(12) **United States Design Patent**  
**Lin et al.**

(10) **Patent No.:** **US D718,659 S**  
(45) **Date of Patent:** **\*\* Dec. 2, 2014**

(54) **BUS**  
(71) Applicant: **BYD Company Limited**, Shenzhen, Guangdong (CN)  
(72) Inventors: **Shangqing Lin**, Shenzhen (CN); **Yuncheng Zhang**, Shenzhen (CN); **Xiaoming Zhong**, Shenzhen (CN); **Yubo Lian**, Shenzhen (CN); **Wang Peng**, Shenzhen (CN)

D291,981 S \* 9/1987 Manning ..... D12/84  
D305,623 S \* 1/1990 Gallitzendoerfer et al. ... D12/84  
D345,120 S \* 3/1994 Normand et al. .... D12/84  
D442,888 S \* 5/2001 Papke et al. .... D12/84  
D537,755 S \* 3/2007 Toth ..... D12/84  
D617,236 S \* 6/2010 Counts ..... D12/84  
D637,520 S \* 5/2011 Kerr et al. .... D12/84  
D678,818 S \* 3/2013 Kerr et al. .... D12/84  
2009/0224570 A1 \* 9/2009 Haswell et al. .... 296/178  
2010/0026019 A1 \* 2/2010 Couto et al. .... 293/118  
2012/0161469 A1 \* 6/2012 Kerr et al. .... 296/178

(73) Assignee: **BYD Company Limited**, Shenzhen, Guangdong (CN)

(\*\*) Term: **14 Years**

(21) Appl. No.: **29/466,780**

(22) Filed: **Sep. 11, 2013**

(30) **Foreign Application Priority Data**

Mar. 12, 2013 (CN) ..... 2013 3 0060331

(51) **LOC (10) Cl.** ..... **12-08**

(52) **U.S. Cl.**  
USPC ..... **D12/84**

(58) **Field of Classification Search**  
CPC ..... B62D 23/00; B62D 25/00; B62D 31/02;  
B62D 31/04; B62D 53/062; B62D 65/00;  
B60G 2202/152; B60G 2300/14; B60P 3/007;  
B21D 53/88  
USPC ..... D12/82, 84, 86, 92, 100; 296/25, 178,  
296/203.01; 280/6.152; 29/897.2  
See application file for complete search history.

(56) **References Cited**

**U.S. PATENT DOCUMENTS**

D257,141 S \* 9/1980 Flesche ..... D12/84  
D268,997 S \* 5/1983 Dubernard ..... D12/84

**OTHER PUBLICATIONS**

Michael C. "Mercedes do Brazil Reaches Its Milestone of 400,000 Buses Sold." Benz Insider., Oct. 13, 2010 [online], [retrieved on Apr. 13, 2014]. Retrieved from the Internet <URL: http://www.benzinsider.com/2010/10/mercedes-do-brazil-reaches-its-milestone-of-400000-buses-sold/>.\*

(Continued)

*Primary Examiner* — Philip S Hyder

*Assistant Examiner* — Darlington Ly

(74) *Attorney, Agent, or Firm* — Finnegan, Henderson, Farabow, Garrett & Dunner, LLP

(57) **CLAIM**

The ornamental design for a bus, as shown and described.

**DESCRIPTION**

FIG. 1 is an enlarged front left perspective view of a bus showing our new design;  
FIG. 2 is an enlarged rear right perspective view thereof;  
FIG. 3 is a front elevation view thereof;  
FIG. 4 is a rear elevation view thereof;  
FIG. 5 is a left side view thereof;  
FIG. 6 is a right side view thereof; and,  
FIG. 7 is a top plan view thereof.  
The broken lines shown in the drawings illustrate portions of the bus that form no part of the claimed design.

**1 Claim, 7 Drawing Sheets**

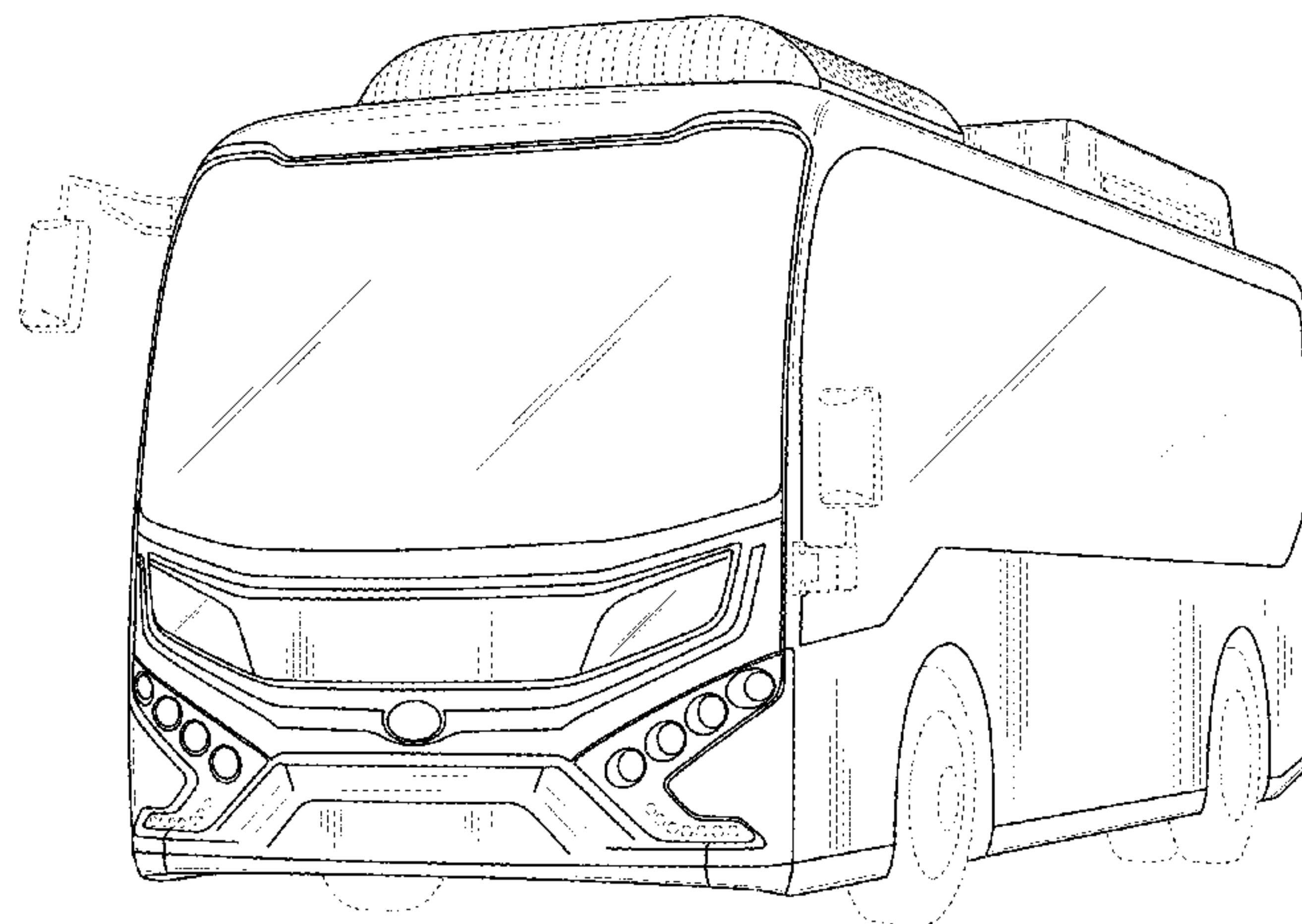

(56)

**References Cited**

OTHER PUBLICATIONS

“World’s Longest Bus? Rejected by Berlin, Big Bendy AutoTram Extra Grand Might Serve China’s Cities.” The World Post., Sep. 5, 2012 [online], [retrieved on Apr. 13, 2014]. Retrieved from the Internet <URL: [http://www.huffingtonpost.com/2012/09/05/worlds-longest-bus-autotram-extra-grand-berlin-china\\_n\\_1858222.html](http://www.huffingtonpost.com/2012/09/05/worlds-longest-bus-autotram-extra-grand-berlin-china_n_1858222.html)>.\*

Sheehan, Matt. “How China’s Electric Car Dreams Became a PR Nightmare in America.” The World Post., Apr. 1, 2014 [online], [retrieved on Apr. 13, 2014]. Retrieved from the Internet <URL: [http://www.huffingtonpost.com/2014/04/01/byd-china-electric-car\\_n\\_4964233.html](http://www.huffingtonpost.com/2014/04/01/byd-china-electric-car_n_4964233.html)>.\*

\* cited by examiner

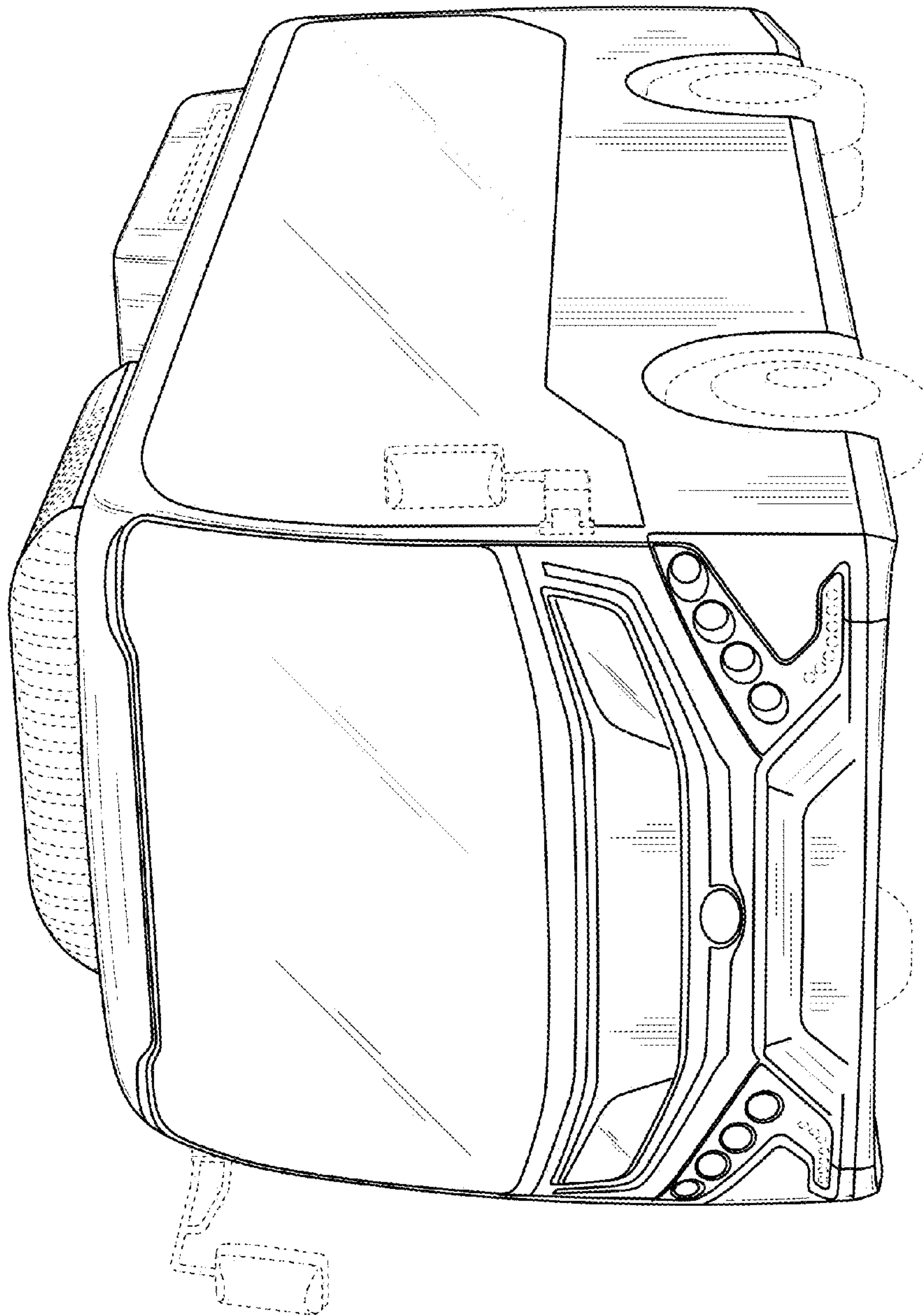

FIG. 1

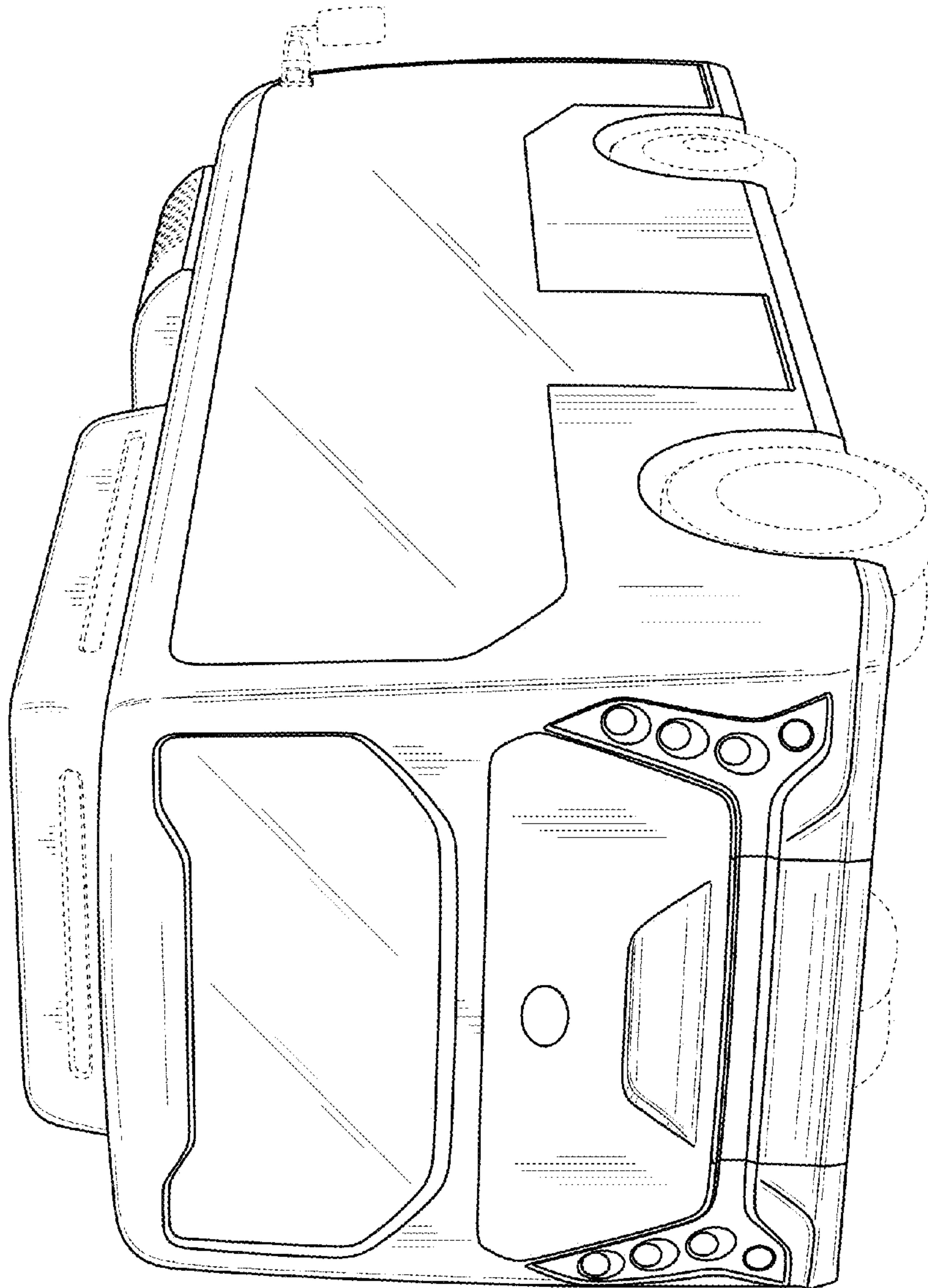
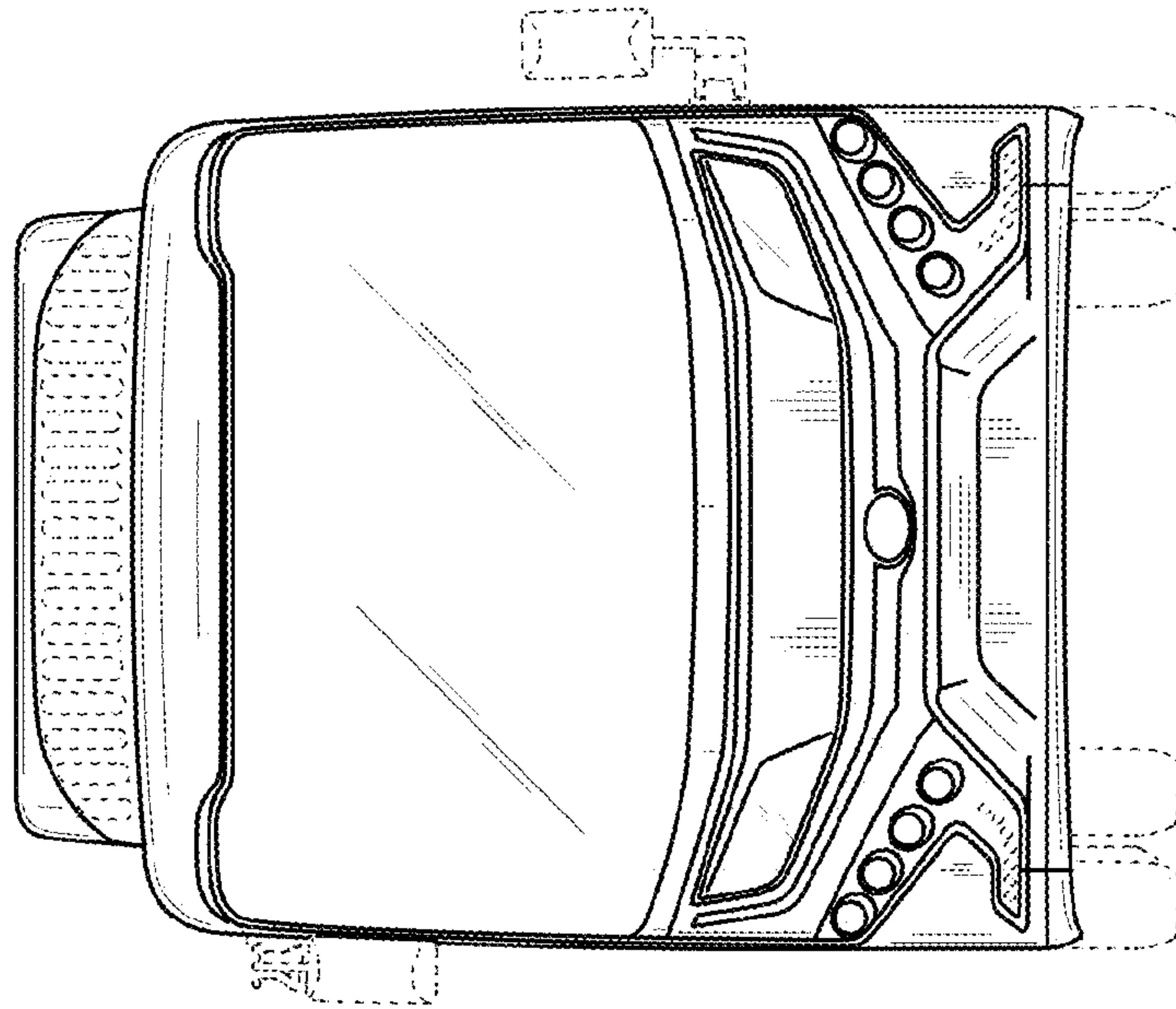

FIG. 2





**FIG. 3**

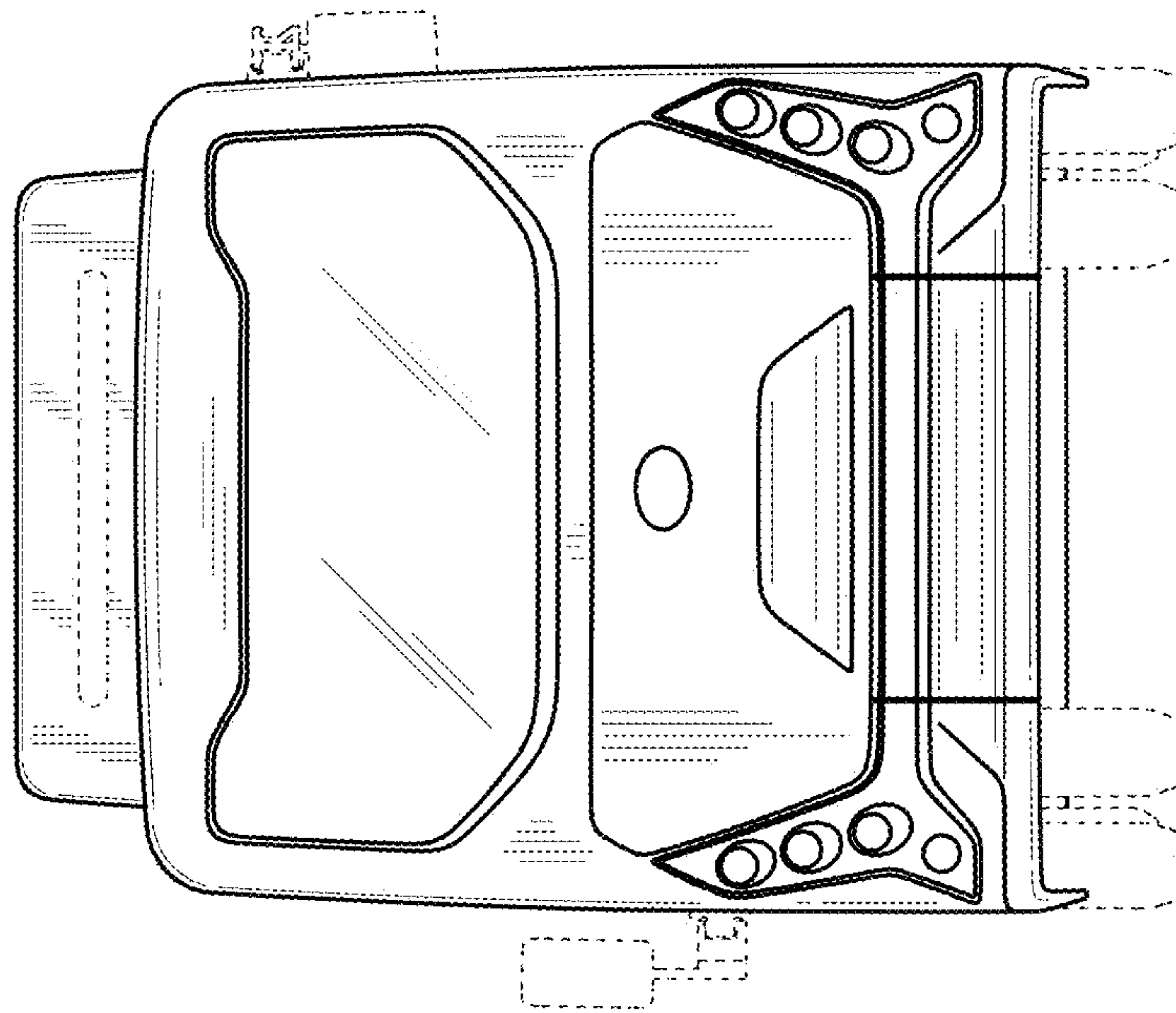
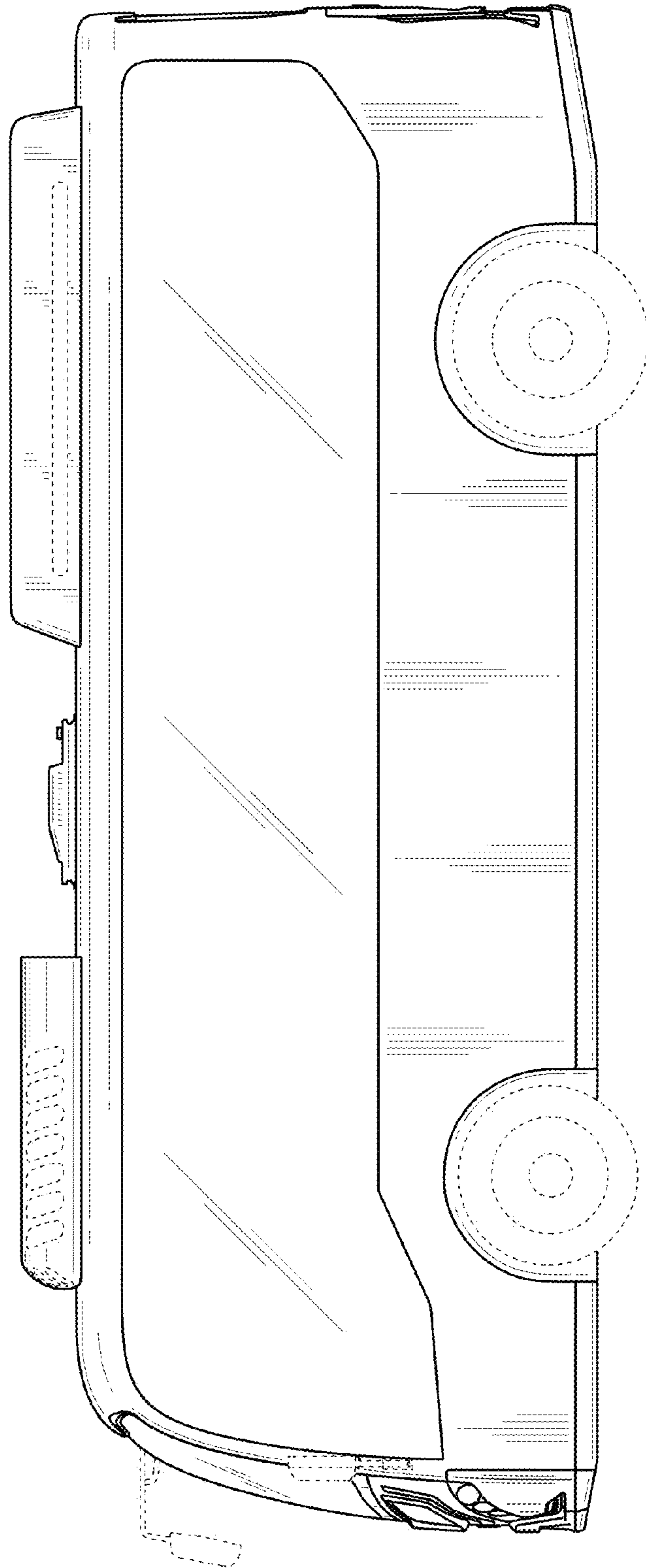
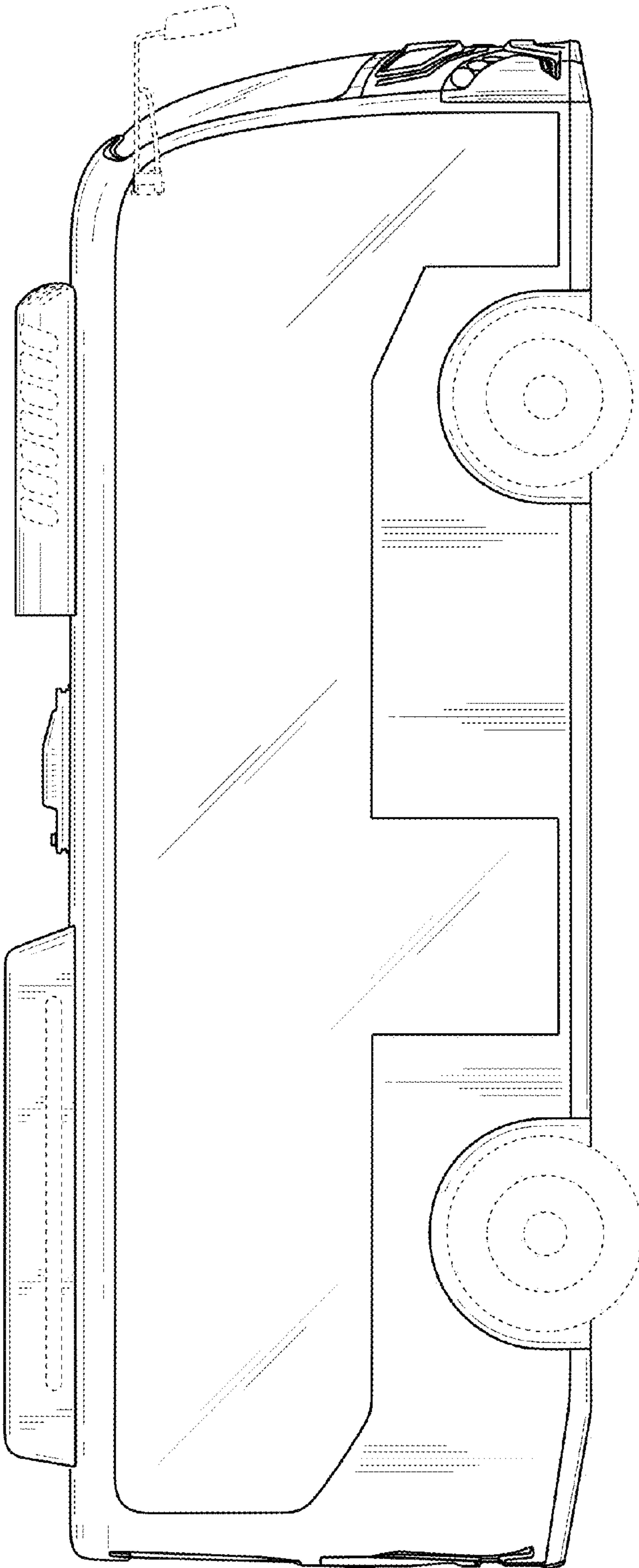

FIG. 4

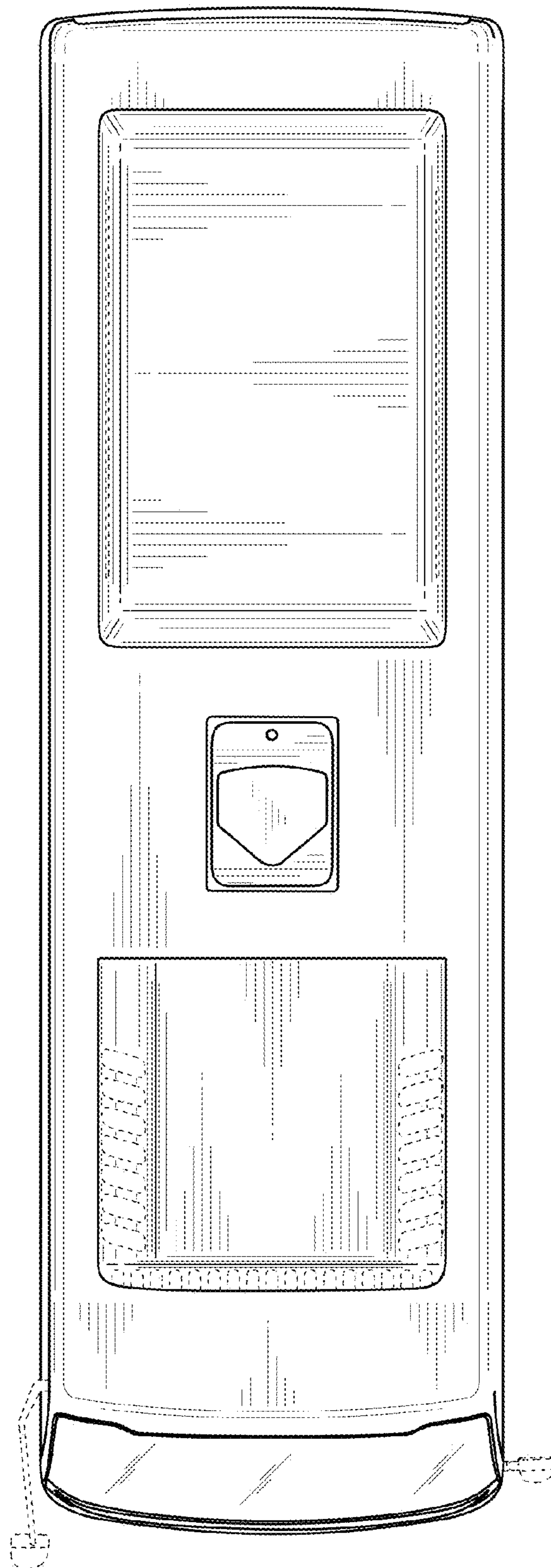

**FIG. 5**



**FIG. 6**





**FIG. 7**