



US00D718607S

(12) **United States Design Patent**
Thrush et al.

(10) **Patent No.:** **US D718,607 S**
(45) **Date of Patent:** **** Dec. 2, 2014**

(54) **RAIL JOINER**

(74) *Attorney, Agent, or Firm* — Holland & Hart LLP

(71) Applicant: **Moddex Group Pty Ltd**, Boronia (AU)

(57) **CLAIM**

The ornamental design for a rail joiner, as shown and described.

(72) Inventors: **Stephen Thrush**, Maryborough (AU);
Dean Vos, Mooroolbark (AU); **Iain White**, St Kilda (AU)

DESCRIPTION

(73) Assignee: **Moddex Group Pty Ltd.**, Victoria (AU)

FIG. 1 is a top and front perspective view of part A of the rail joiner, showing half of my new design;

(**) Term: **14 Years**

FIG. 2 is a rear perspective view of part A of the design illustrated in FIG. 1;

(21) Appl. No.: **29/447,932**

FIG. 3 is a top and front perspective view of part B of the rail joiner, showing the other half of my new design;

(22) Filed: **Mar. 7, 2013**

FIG. 4 is a rear perspective view of the part B of the design;

(51) **LOC (10) Cl.** **08-06**

FIG. 5 is a top and front perspective view of the design assembly with part A and part B in a 180° configuration;

(52) **U.S. Cl.**
USPC **D8/323**

FIG. 6 is a rear perspective view of the design assembly with part A and part B in a 180° configuration;

(58) **Field of Classification Search**
USPC D8/323; 256/13.1, 59, 65.01, 65.15,
256/65.16, 65.02, 65.07, 65.11, 65.03;
49/383, 384; 403/6, 26, 52, 68, 79,
403/113, 119; 16/86.2, 231, 343
See application file for complete search history.

FIG. 7 is a top plan view of the design assembly with parts A and B in a 180° configuration;

FIG. 8 is a top and front perspective view of the design assembly with parts A and B in a 90° configuration;

FIG. 9 is a top plan view of the design assembly with parts A and B in a 90° configuration;

FIG. 10 is a rear perspective view of the design assembly with parts A and B in a 90° configuration;

FIG. 11 is a bottom plan view of the design assembly with parts A and B in a 270° configuration;

FIG. 12 is a top and front perspective view of the design assembly with parts A and B in a 270° configuration; and,

FIG. 13 is a rear perspective view of the design assembly with parts A and B in a 270° configuration.

(56) **References Cited**

U.S. PATENT DOCUMENTS

D616,282	S	*	5/2010	Cosby et al.	D8/323
D661,173	S	*	6/2012	Caffin et al.	D8/323
2003/0108380	A1	*	6/2003	Schweitz et al.	403/79
2009/0320240	A1	*	12/2009	Wang et al.	16/231

* cited by examiner

Primary Examiner — Doris Clark

1 Claim, 13 Drawing Sheets

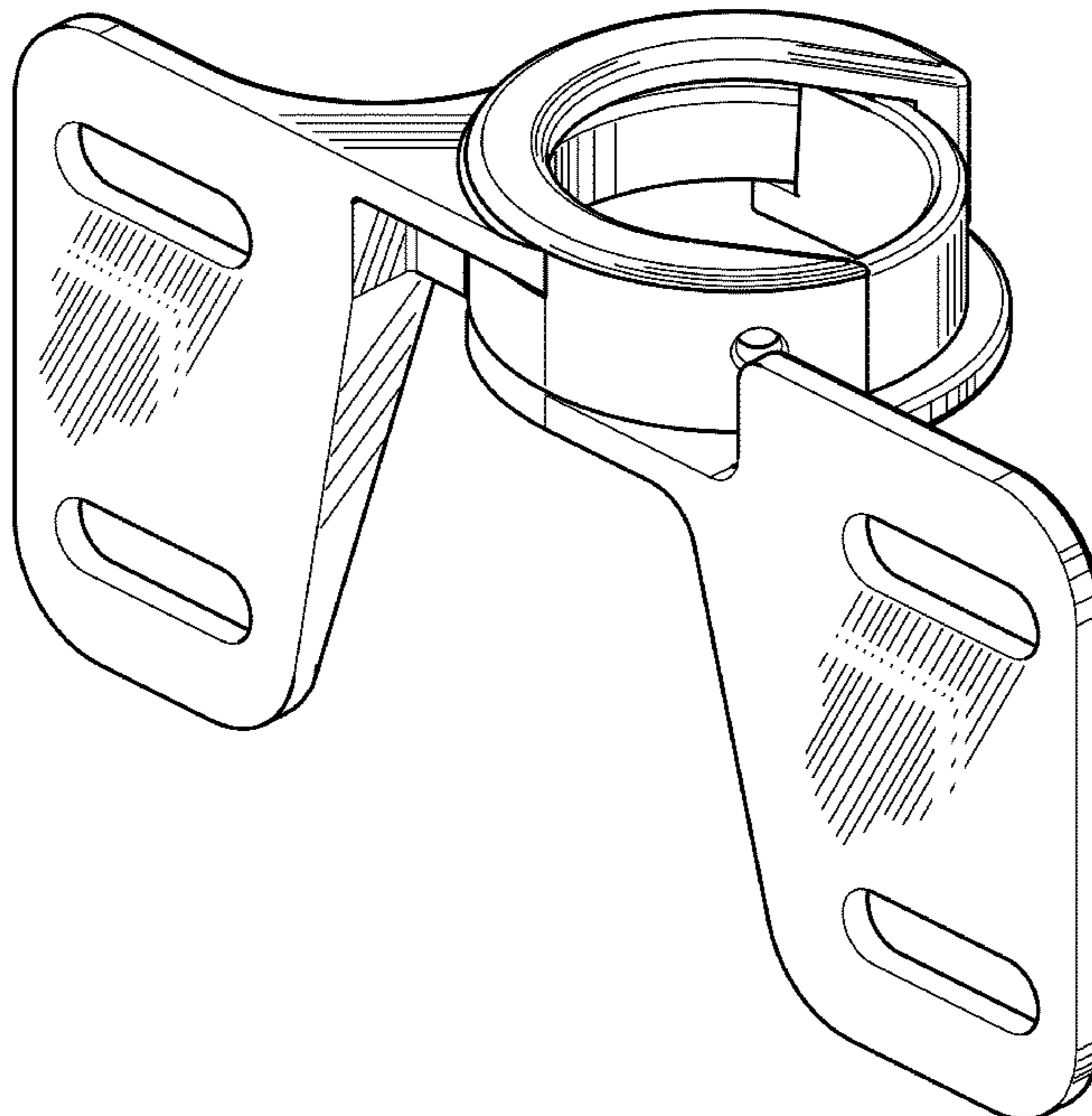

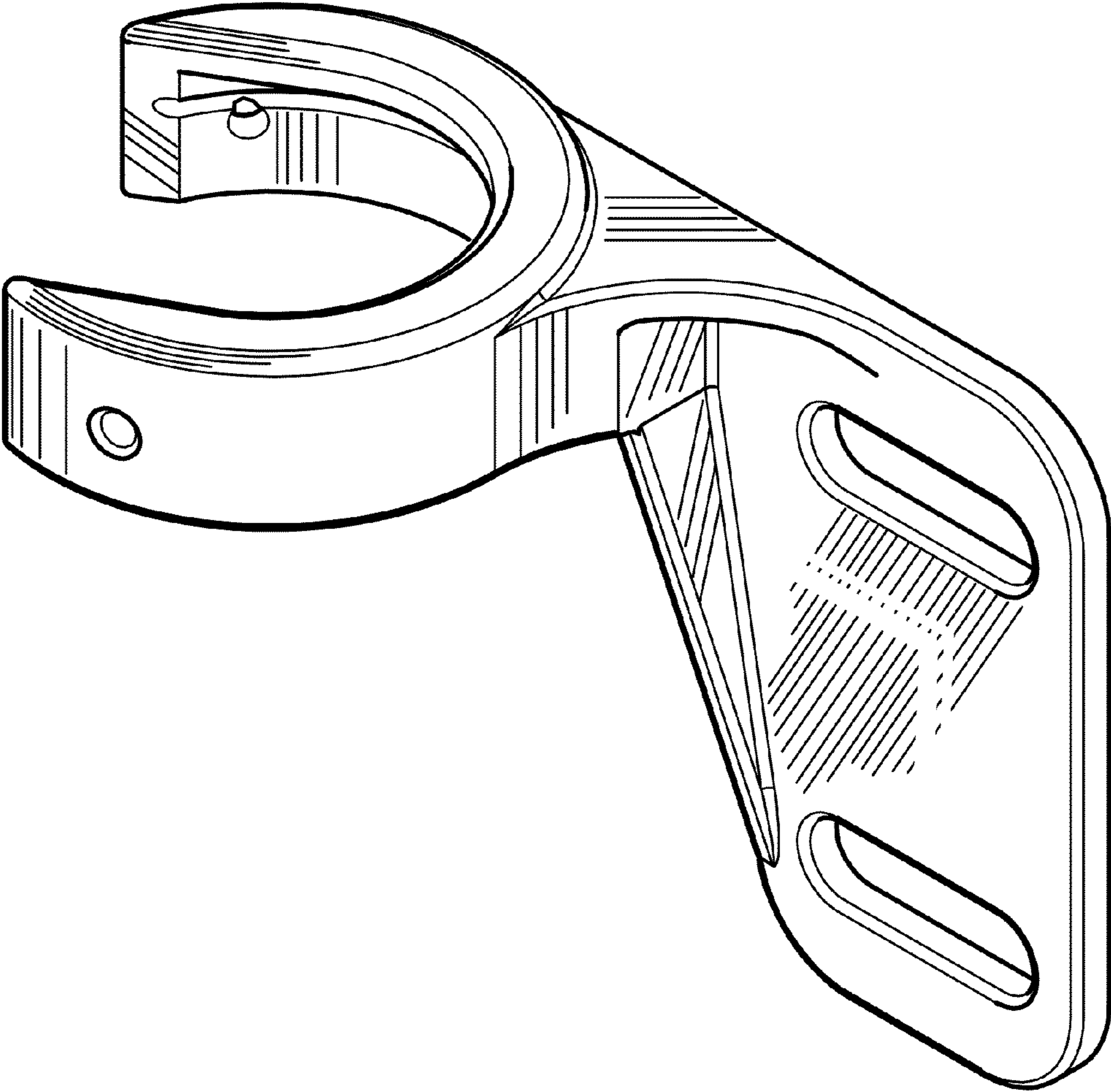

FIG. 1

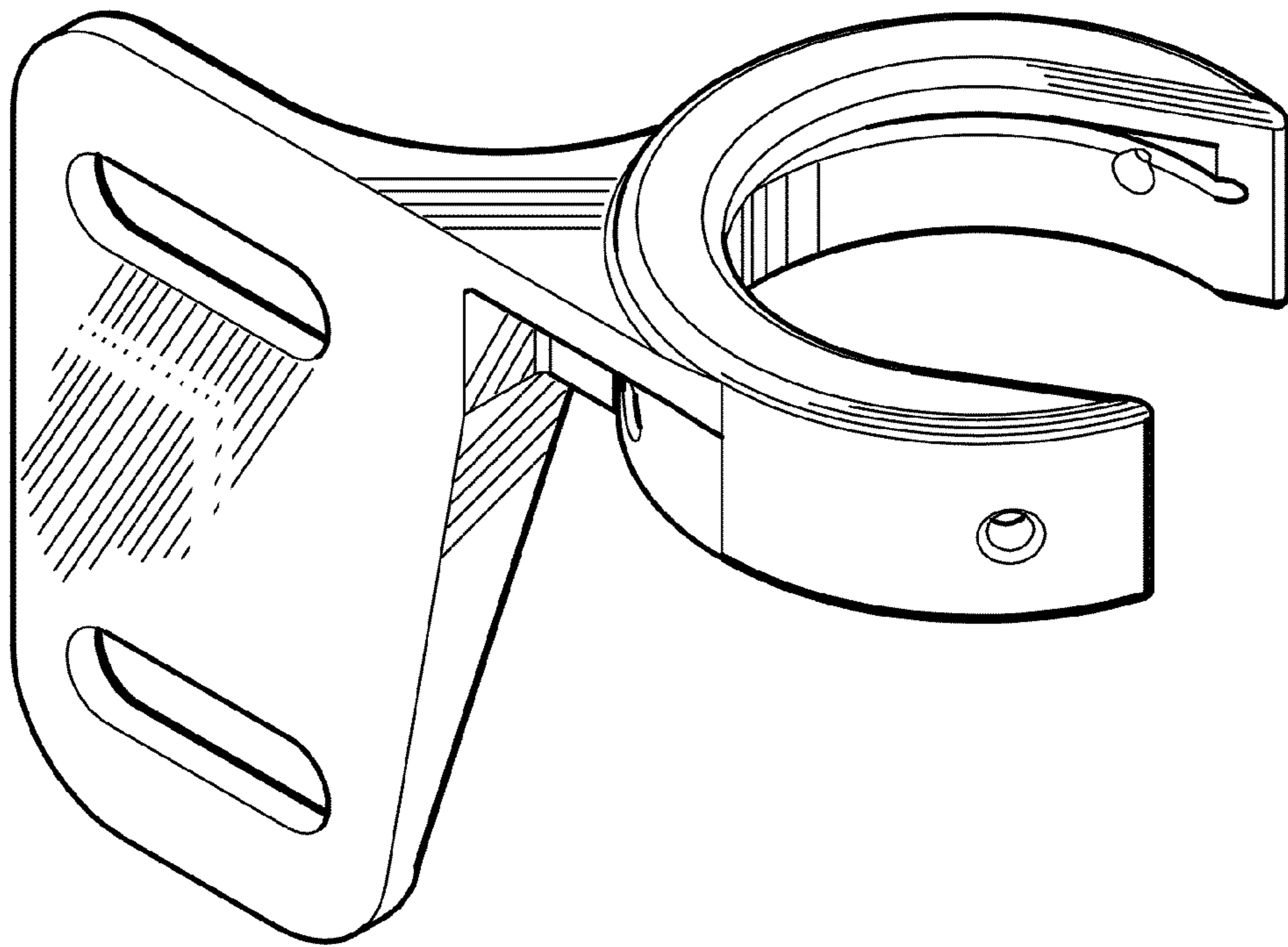

FIG. 2

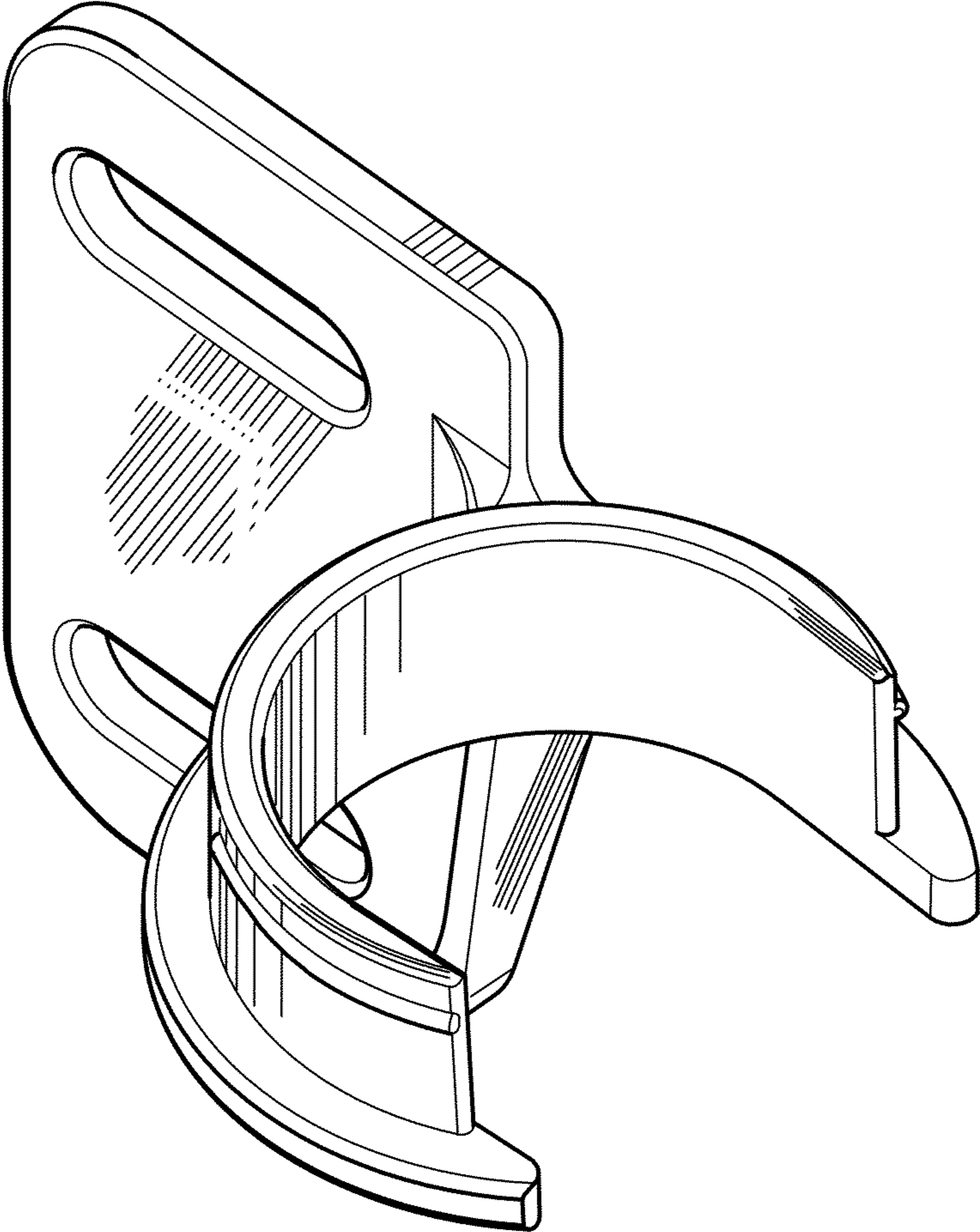

FIG. 3

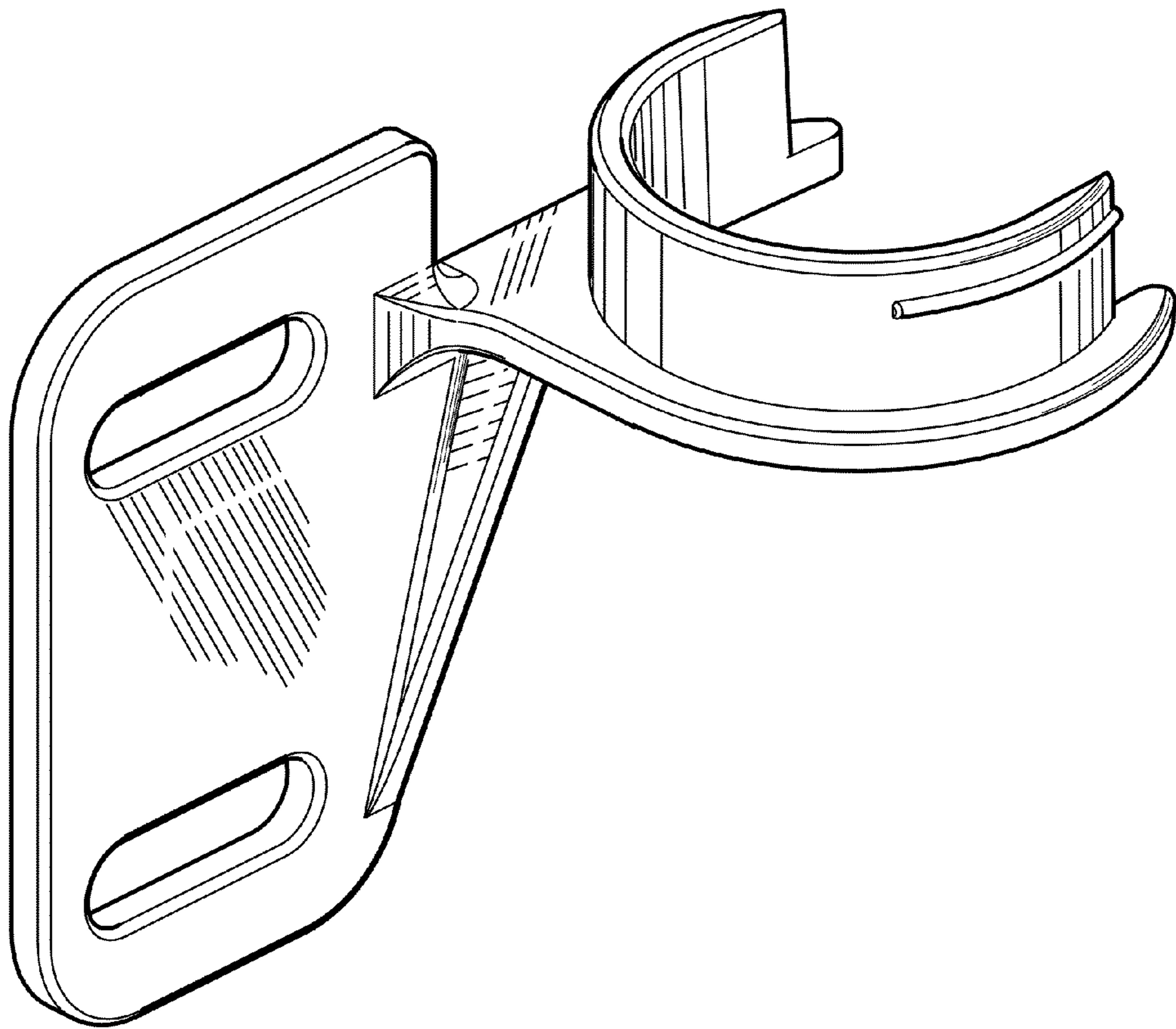

FIG. 4

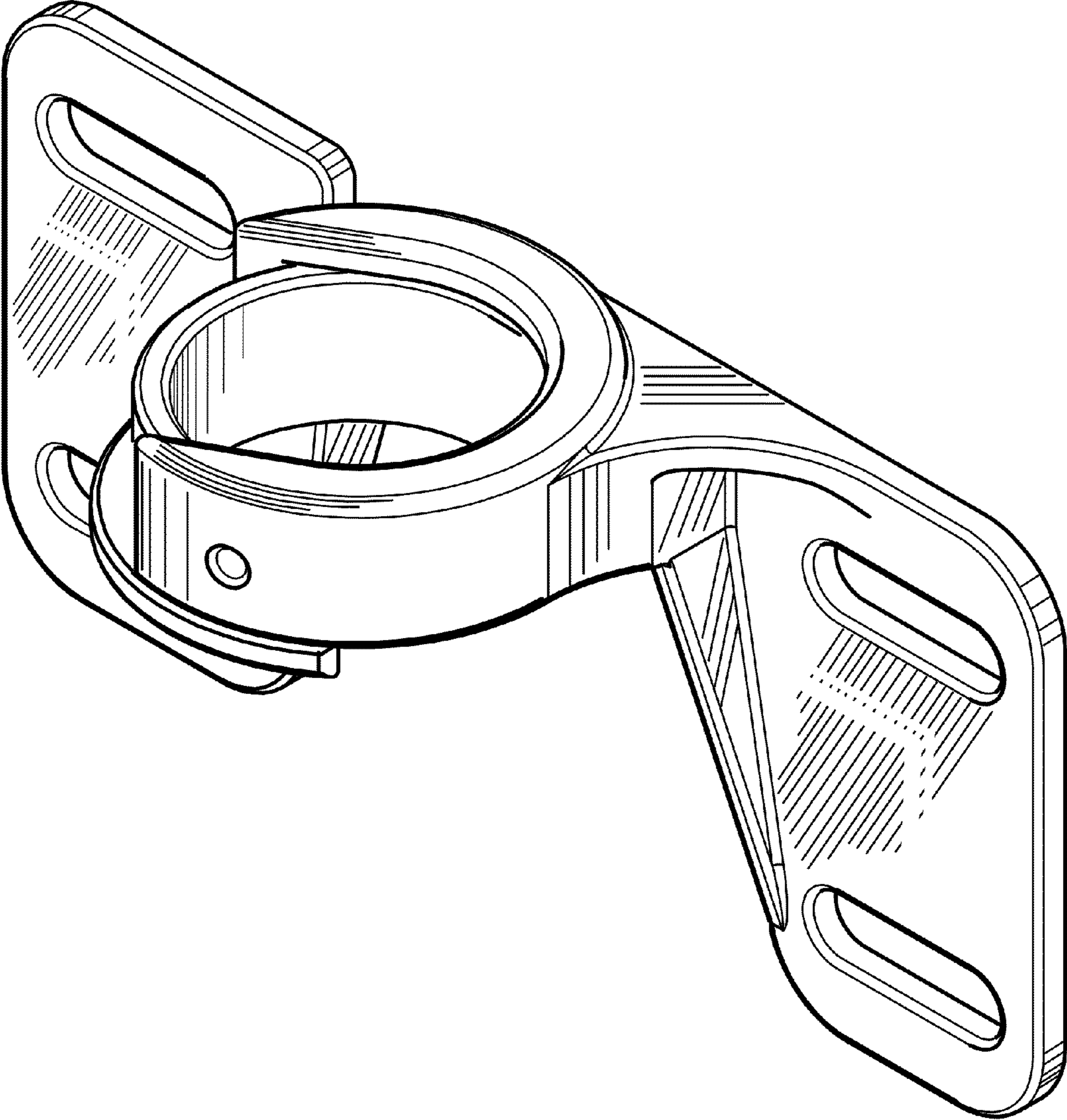

FIG. 5

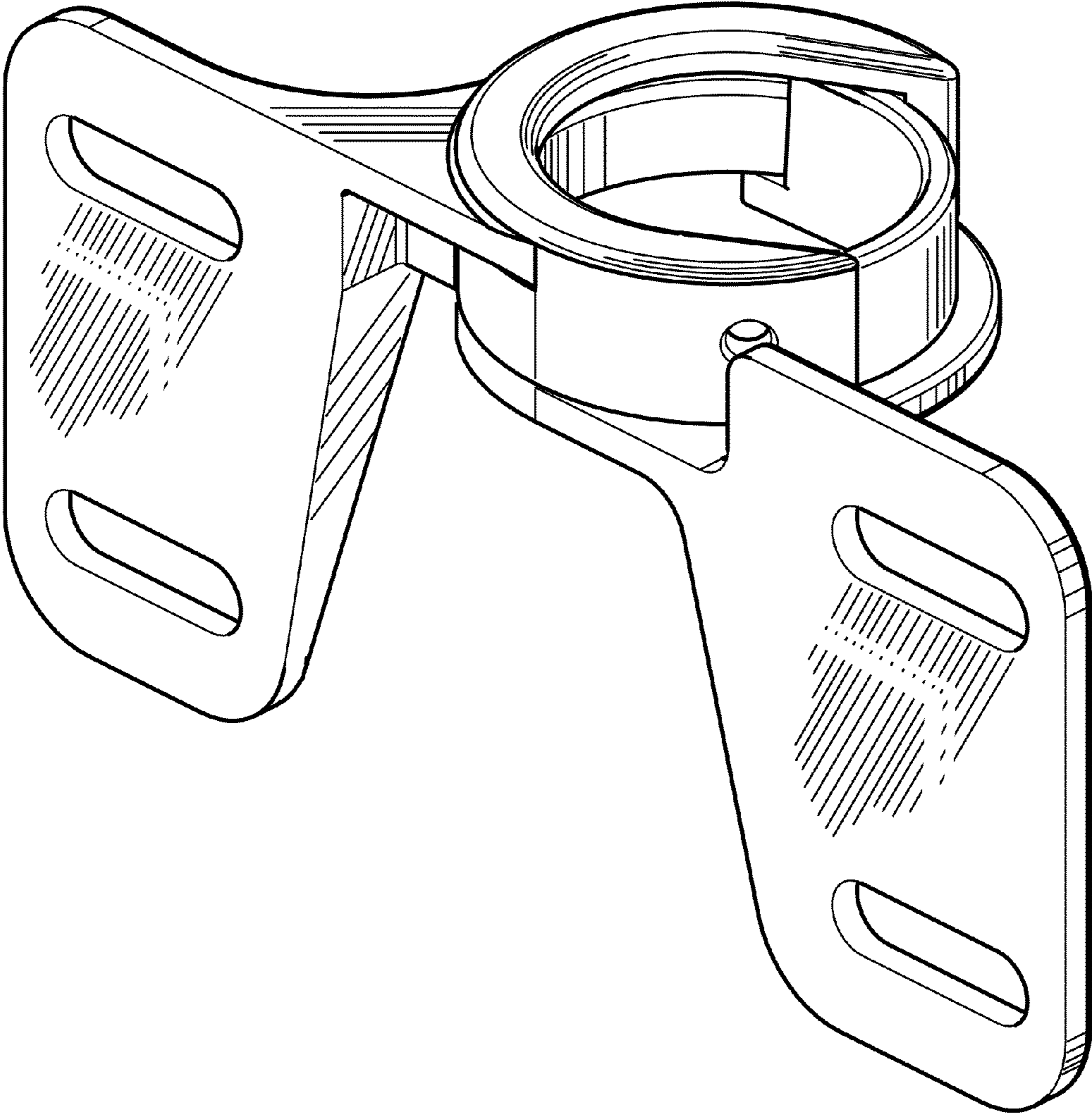

FIG. 6

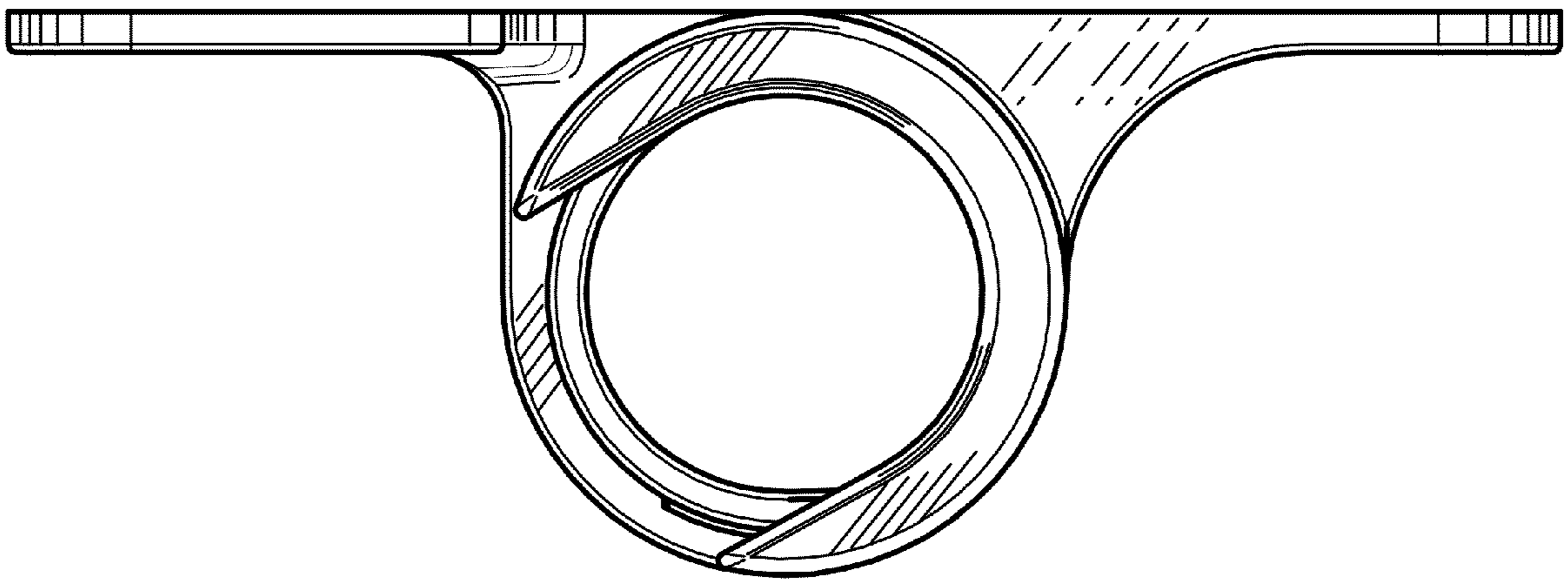

FIG. 7

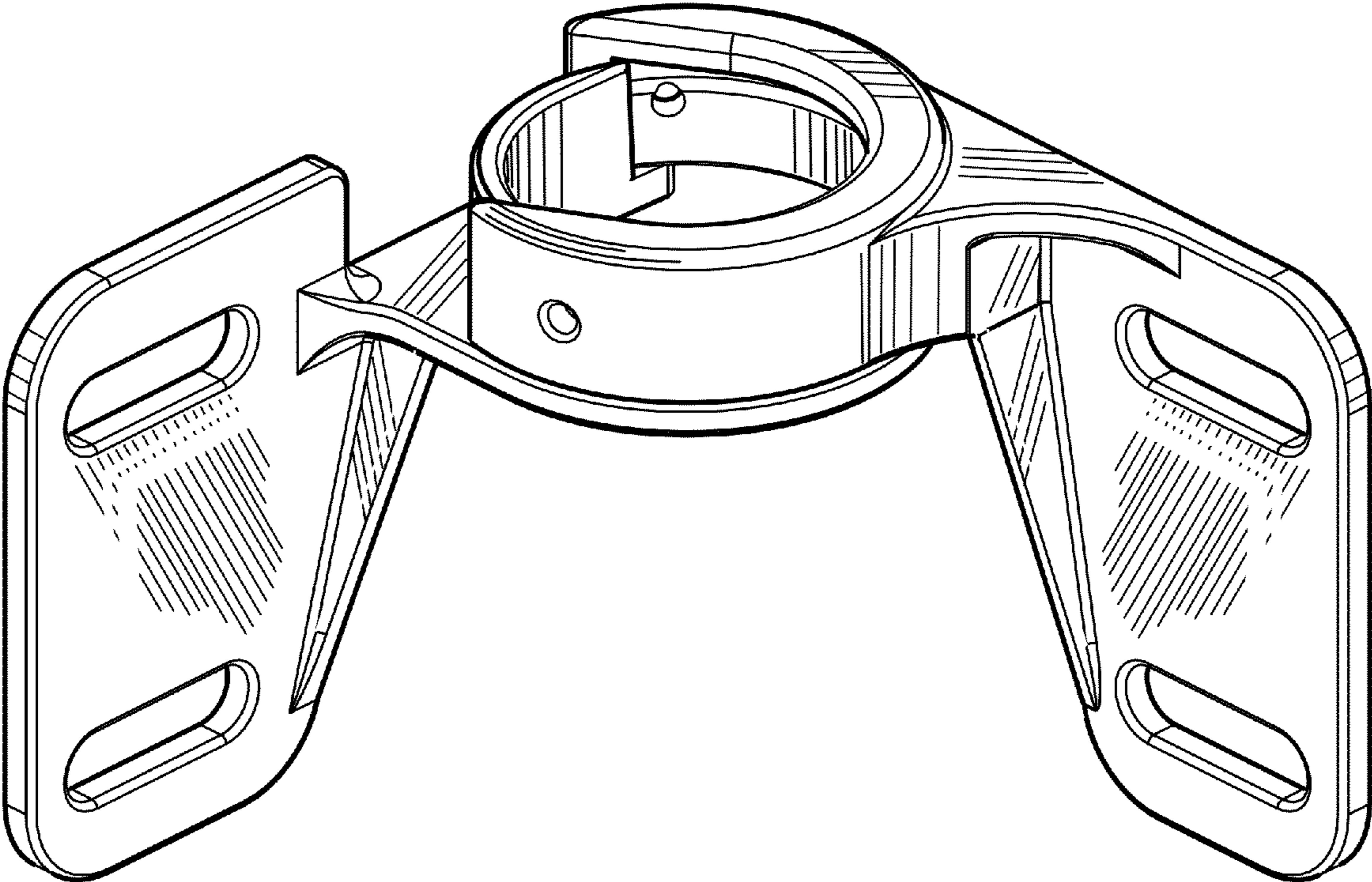

FIG. 8

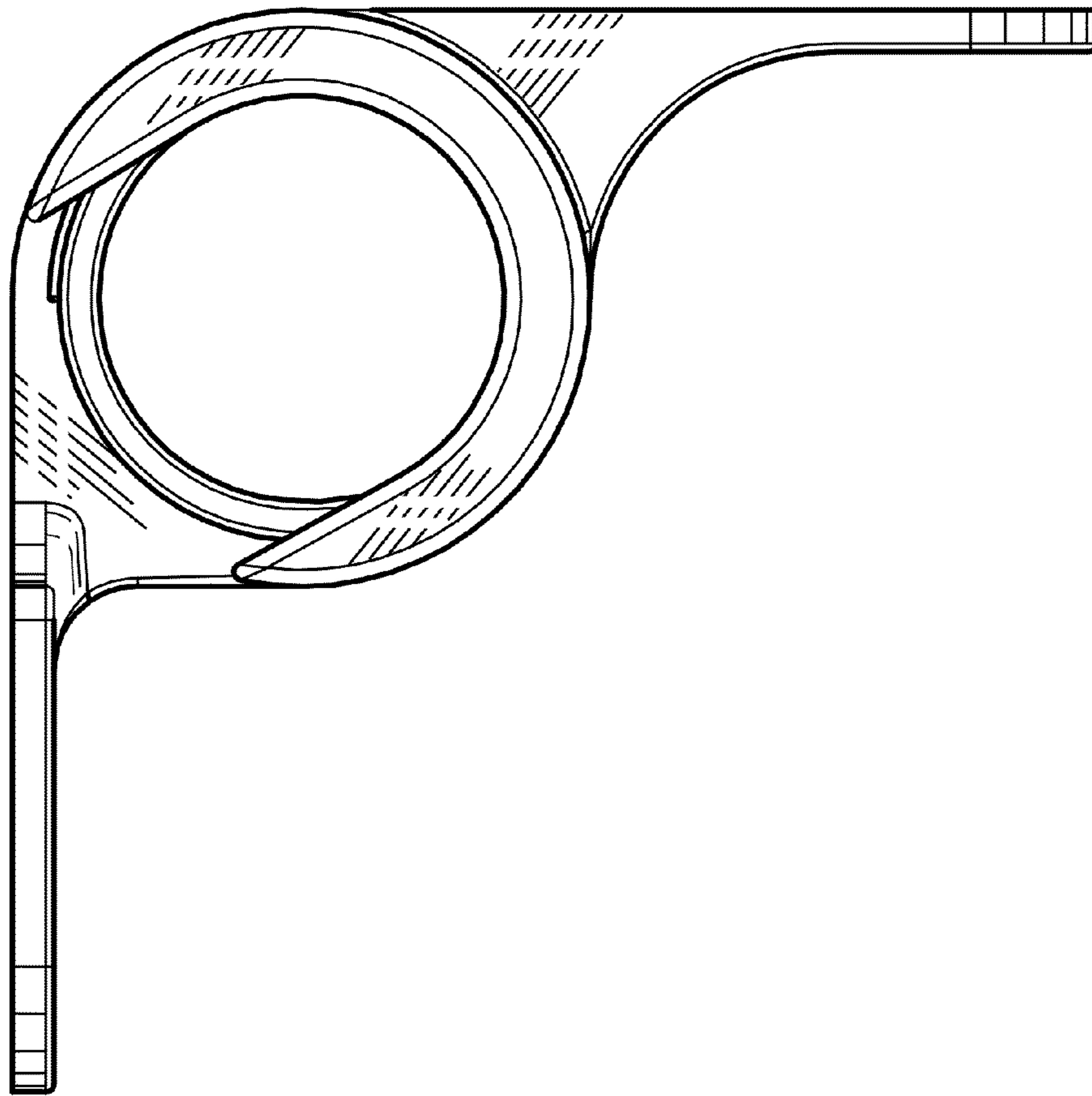

FIG. 9

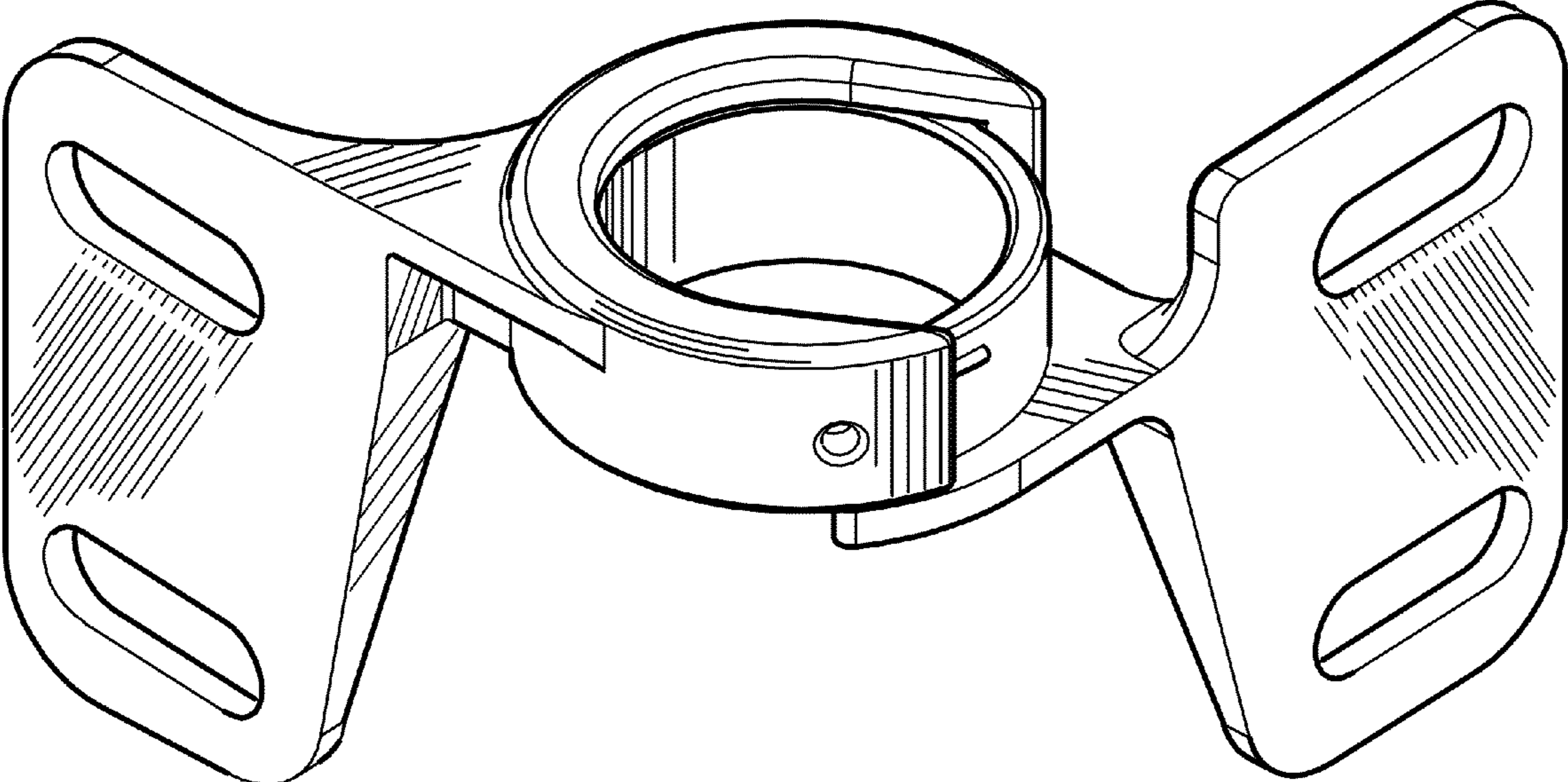

FIG. 10

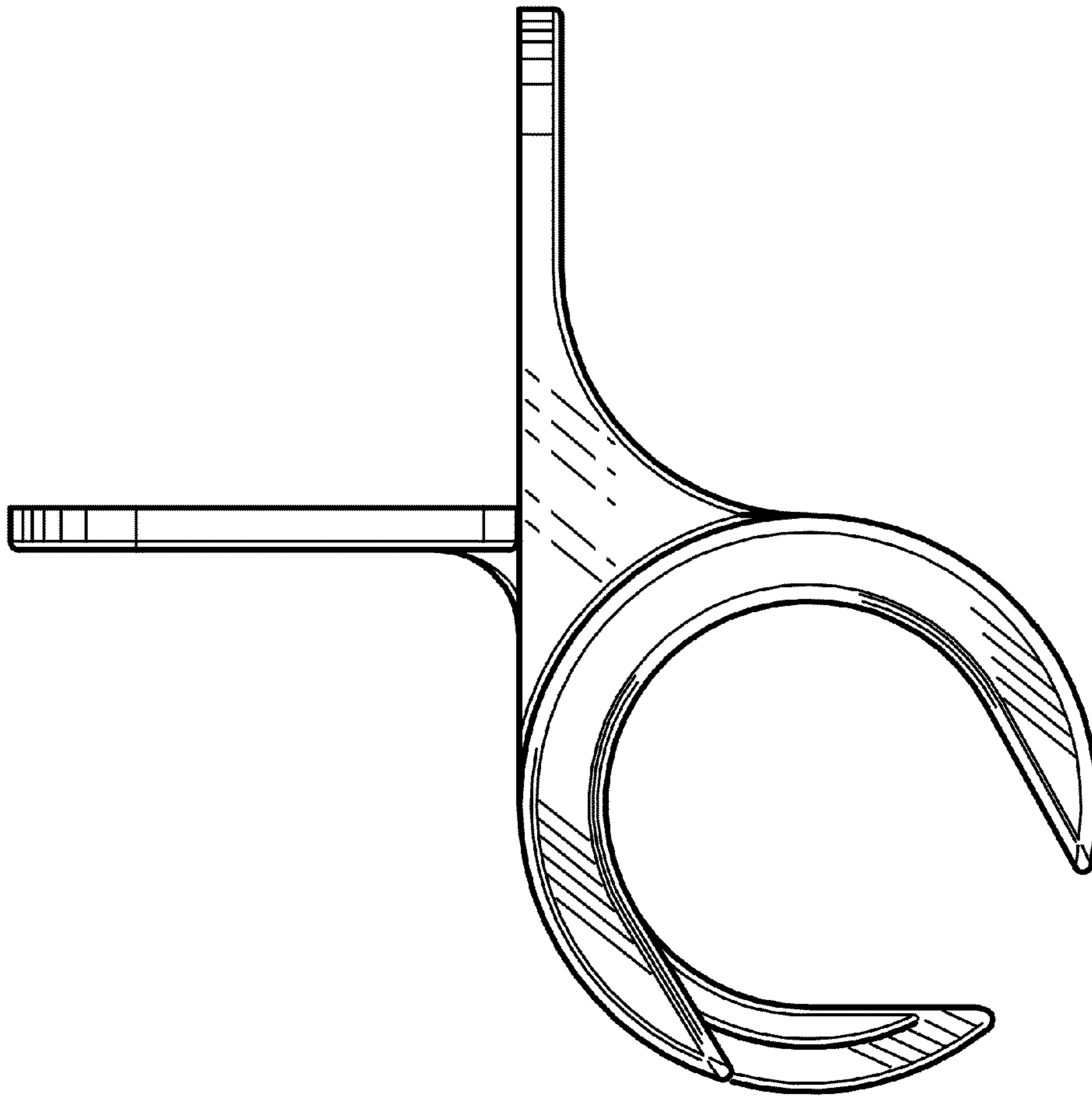

FIG. 11

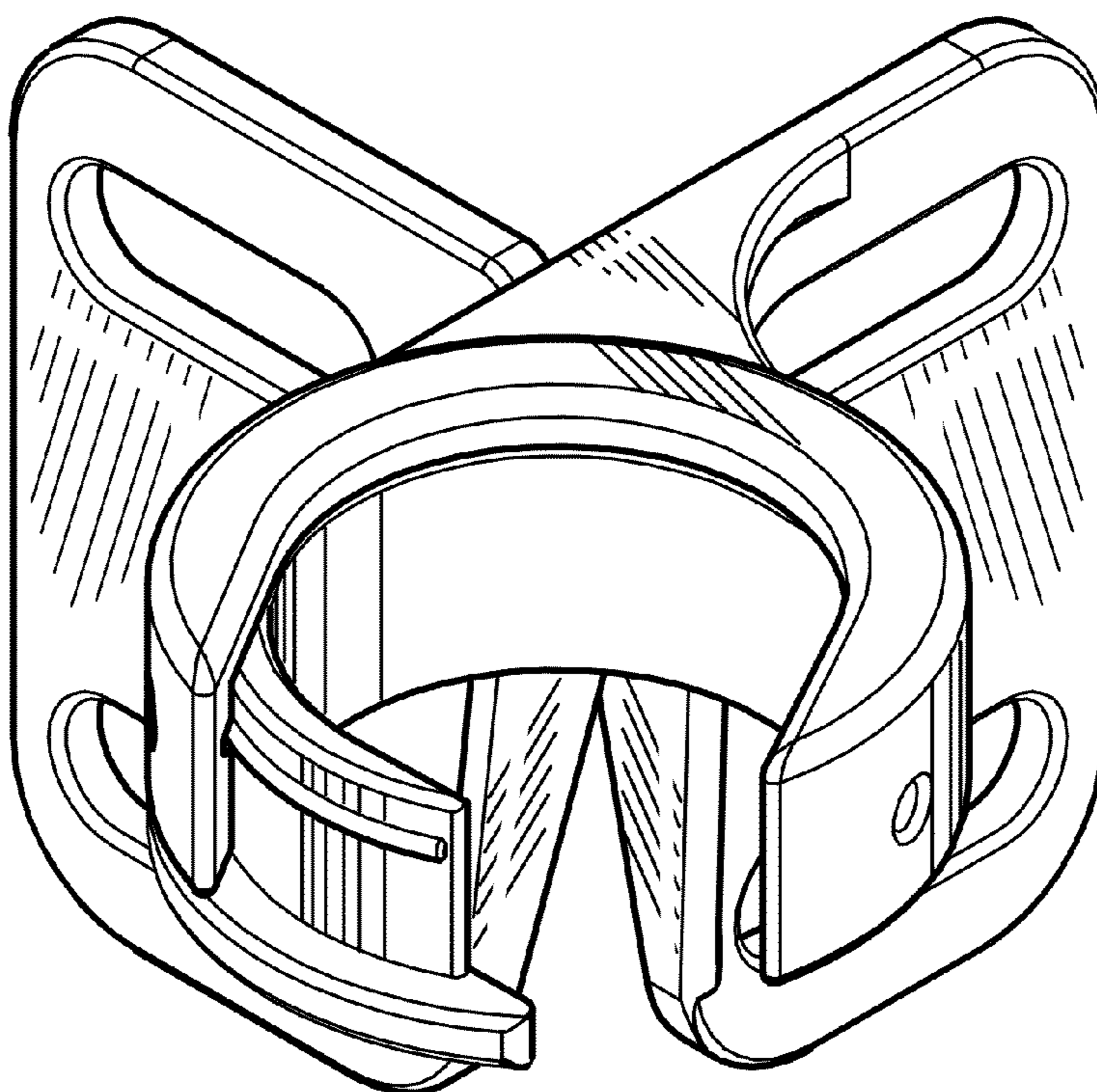

FIG. 12

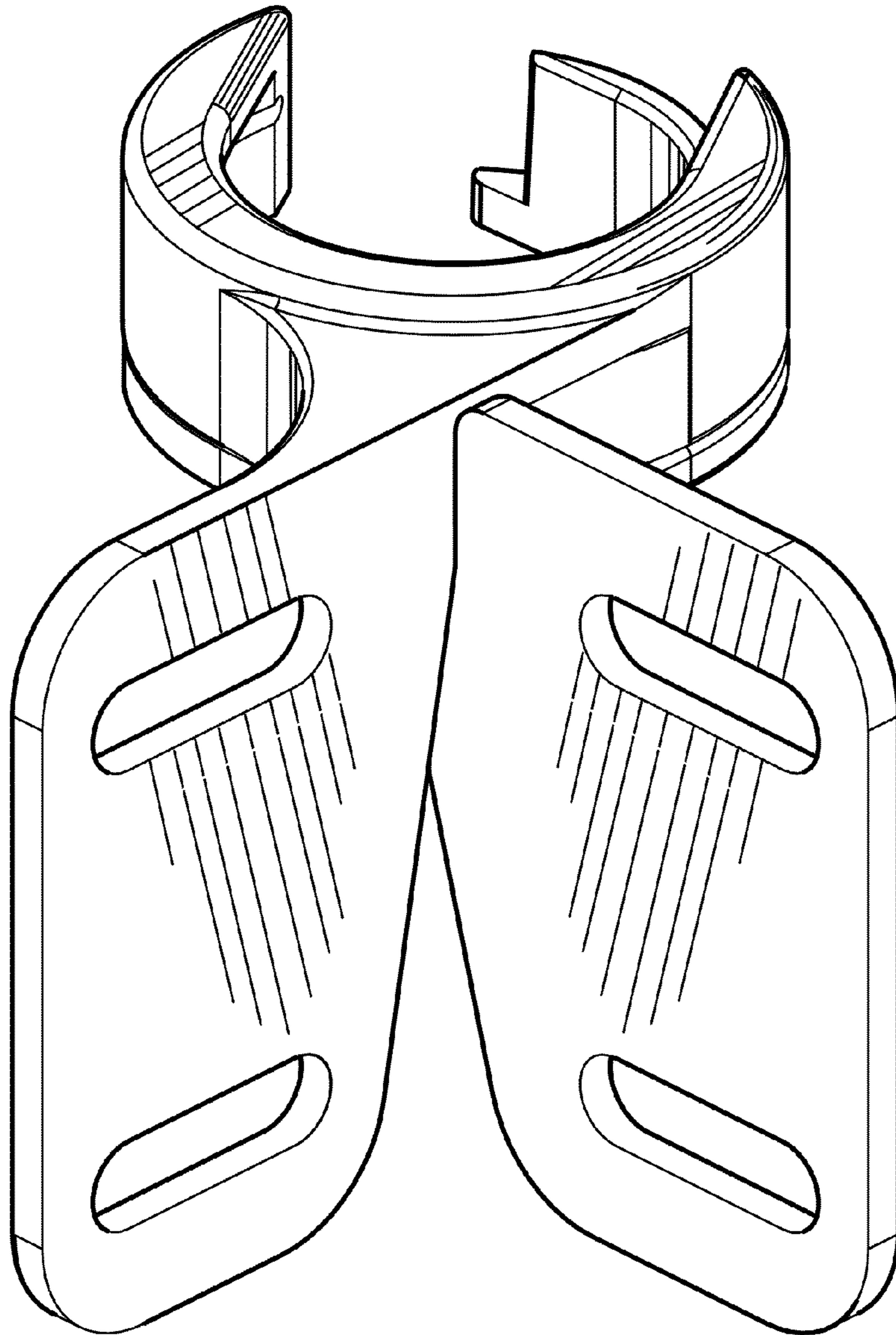

FIG. 13