



US00D718549S

(12) **United States Design Patent**
Akkad

(10) **Patent No.:** **US D718,549 S**
(45) **Date of Patent:** **** Dec. 2, 2014**

(54) **TRAMPOLINE SAUCER CHAIR**
(71) Applicant: **Idea Nuova, Inc.**, New York, NY (US)
(72) Inventor: **Benjamin S. Akkad**, New York, NY (US)

2,649,901 A 8/1953 Johnson
D171,176 S 12/1953 Yellen
D171,265 S * 1/1954 Phillips D6/375
2,684,709 A * 7/1954 Schawinsky 297/411.41
2,691,410 A 10/1954 Boucher

(Continued)

(73) Assignee: **Idea Nuova, Inc.**, New York, NY (US)

FOREIGN PATENT DOCUMENTS

(**) Term: **14 Years**

CN 87201431 U 2/1988
CN 2103938 U 5/1992

(21) Appl. No.: **29/493,607**

(Continued)

(22) Filed: **Jun. 11, 2014**

OTHER PUBLICATIONS

(51) **LOC (10) Cl.** **06-01**

Office Action Issued Oct. 18, 2010 in U.S. Appl. No. 12/544,256.

(52) **U.S. Cl.**
USPC **D6/368**

(Continued)

(58) **Field of Classification Search**
USPC D6/334-336, 348-349, 363, 366-369,
D6/371-376, 379, 716, 716.1-716.4;
5/102; 297/16.1, 16.2, 31, 34, 45-47,
297/50, 56, 271.6, 314, 411.41, 440.11,
297/440.24, 448.1, 451.4, 452.12, 452.13;
473/197, 431, 456

Primary Examiner — Ricky Pham
(74) *Attorney, Agent, or Firm* — Panitch Schwarze Belisario & Nadel LLP

See application file for complete search history.

(57) **CLAIM**
The ornamental design for a trampoline saucer chair, as shown and described.

(56) **References Cited**

DESCRIPTION

U.S. PATENT DOCUMENTS

244,216 A 7/1881 Fenby
398,943 A 3/1889 Crandall
615,476 A 12/1898 Chapman
1,027,692 A 5/1912 Cole
1,185,568 A 5/1916 Zeunert
1,263,717 A 4/1918 Stone
1,443,734 A 1/1923 Clyde
1,939,743 A 12/1933 Warner
1,942,112 A 1/1934 McQuilkin
2,381,574 A 8/1945 Clarin
2,473,090 A 6/1949 Becker
2,587,543 A 2/1952 Smith
2,590,049 A 3/1952 Sidlinger
D168,212 S * 11/1952 Cicchelli D6/379

FIG. 1 is a front perspective view of a trampoline saucer chair in accordance with a preferred embodiment of my new design;
FIG. 2 is a front elevation view thereof;
FIG. 3 is a left side elevation view thereof, a right side elevation view thereof being a mirror image;
FIG. 4 is a rear elevation view thereof;
FIG. 5 is a top plan view thereof; and,
FIG. 6 is a bottom plan view thereof.
The broken lines in the figures are for the purpose of showing environmental structure and form no part of the claimed design.

1 Claim, 5 Drawing Sheets

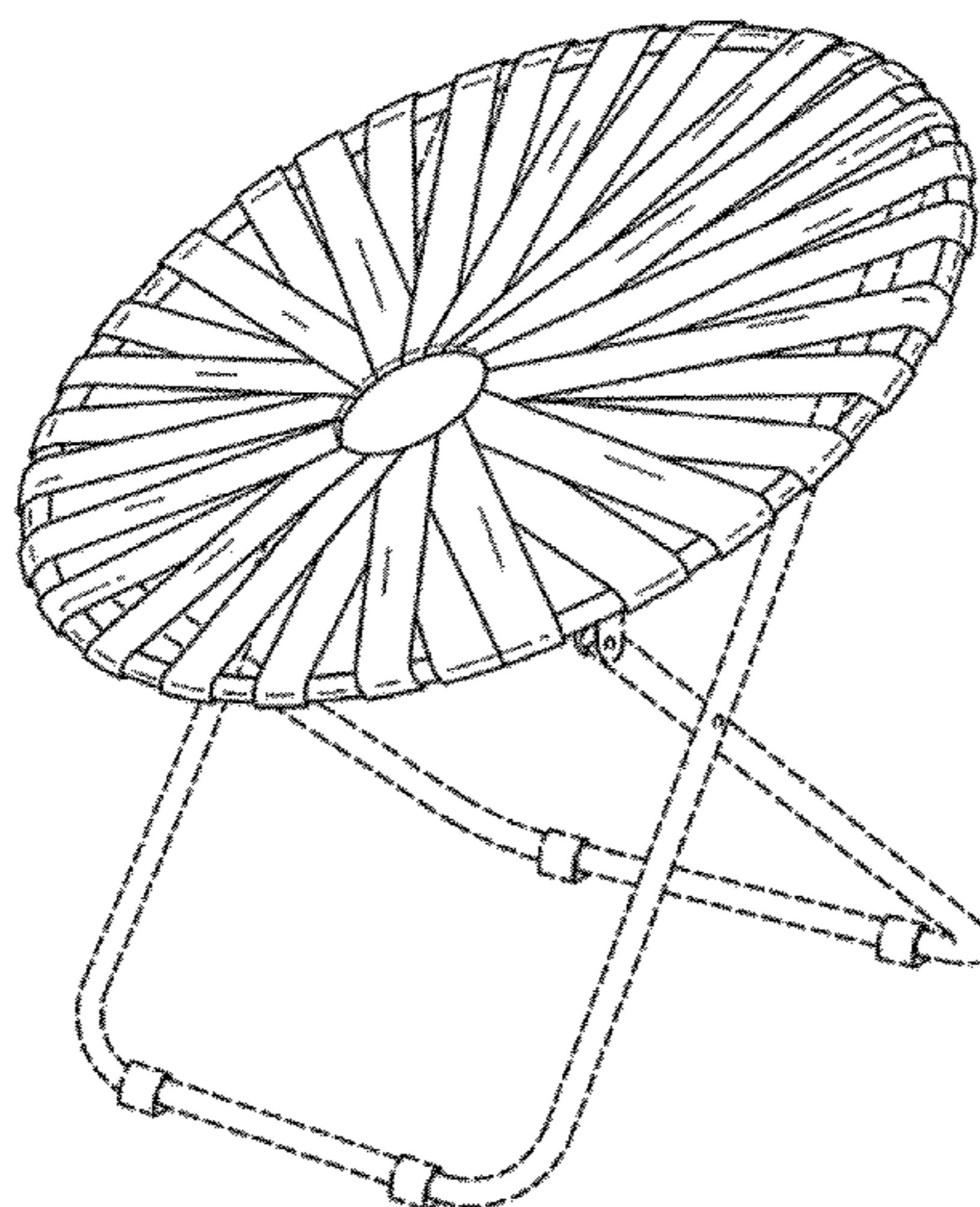

(56)

References Cited

U.S. PATENT DOCUMENTS

2,712,349 A	7/1955	LeVoir		D433,244 S	11/2000	Zheng	
2,713,890 A	7/1955	Mack		D433,574 S	11/2000	Zheng	
2,723,712 A *	11/1955	Yellen	297/440.11	6,149,238 A	11/2000	Tsai	
2,733,755 A	2/1956	Boucher		6,179,374 B1	1/2001	Tang	
2,763,318 A	9/1956	Bertoia		6,209,951 B1	4/2001	Han	
D179,376 S *	12/1956	Breed	D6/366	6,231,119 B1	5/2001	Zheng	
D180,210 S	4/1957	Uretsky		6,237,993 B1	5/2001	Zheng	
D184,202 S	12/1958	Yuen		6,238,001 B1	5/2001	Yoran	
2,902,084 A	9/1959	Stevens		6,241,311 B1	6/2001	Zheng	
2,916,744 A *	12/1959	May et al.	5/102	6,247,748 B1	6/2001	Zheng	
2,930,430 A *	3/1960	Bloom	297/271.6	6,264,271 B1	7/2001	Munn et al.	
3,123,396 A	3/1964	Searle		6,283,046 B1	9/2001	Tseng	
3,124,387 A	3/1964	MacLaren		6,296,304 B1	10/2001	Zheng	
3,136,272 A	6/1964	Sprigman		6,302,479 B1	10/2001	Zheng	
3,180,685 A *	4/1965	Rogalski et al.	297/440.24	6,312,343 B1 *	11/2001	Cho	473/197
3,635,520 A	1/1972	Roher et al.		6,322,138 B1	11/2001	Tang	
3,656,808 A	4/1972	Chang		6,332,646 B1	12/2001	Tseng	
3,694,030 A	9/1972	Grosfillex		6,354,657 B1	3/2002	Nelson et al.	
3,767,192 A	10/1973	Eriksson		6,364,411 B1	4/2002	Zheng	
3,838,883 A	10/1974	Machen		6,371,553 B1	4/2002	Tang	
3,941,416 A	3/1976	Uchida		D456,628 S	5/2002	Satoshi	
4,045,045 A	8/1977	Boucher et al.		6,382,715 B1	5/2002	Tang	
4,047,752 A	9/1977	Rohr		6,382,729 B1	5/2002	Wu	
4,105,244 A	8/1978	Colby		6,402,230 B1	6/2002	Tang	
4,118,065 A	10/1978	Watkins		D460,280 S	7/2002	Fox	
4,193,630 A	3/1980	Steele		6,419,311 B1	7/2002	Tang	
4,231,582 A	11/1980	Moss		6,447,057 B1	9/2002	Chen	
4,258,951 A	3/1981	Groom		6,454,348 B1	9/2002	Wu	
4,290,643 A	9/1981	Logan, III		6,488,331 B2	12/2002	Chen	
D262,674 S	1/1982	Logan, III		6,494,530 B1	12/2002	Zheng	
D267,057 S	11/1982	Koehm		D468,939 S	1/2003	Zheng	
D270,557 S	9/1983	Williams		6,505,885 B1	1/2003	Tang	
4,514,009 A	4/1985	Vanderminde et al.		6,547,322 B2	4/2003	Marx	
4,605,261 A	8/1986	Lee		6,554,717 B2	4/2003	Cho	
D287,909 S	1/1987	Weiss		D475,860 S *	6/2003	Yang	D6/367
4,652,047 A	3/1987	Chan		6,601,912 B1	8/2003	Chen	
D290,557 S	6/1987	Salvati et al.		6,607,240 B2	8/2003	Zheng	
4,671,566 A	6/1987	Knapp et al.		6,629,722 B1	10/2003	Tang	
4,685,725 A	8/1987	Helfrich		6,634,705 B1	10/2003	Zheng	
D292,048 S	9/1987	Shaffer		6,637,811 B2	10/2003	Zheng	
4,715,650 A	12/1987	Berman et al.		6,644,731 B2	11/2003	Tang	
4,717,201 A	1/1988	Barras		6,669,281 B1	12/2003	Huang	
4,789,123 A	12/1988	Mattsson		6,682,135 B2	1/2004	Zheng	
4,826,241 A	5/1989	Barras		D486,310 S	2/2004	Goldy	
4,867,505 A	9/1989	Parker		6,698,827 B2	3/2004	Le Gette et al.	
4,889,383 A	12/1989	Jones		6,702,371 B2	3/2004	Zheng	
4,934,638 A	6/1990	Davis		6,715,824 B2	4/2004	Zheng	
D310,605 S	9/1990	Kwon		6,736,450 B2	5/2004	Miyagi	
5,058,950 A	10/1991	Mann		6,755,462 B2	6/2004	Zheng	
5,176,393 A	1/1993	Robertson et al.		6,779,838 B2	8/2004	Chang	
5,246,265 A	9/1993	Nagan et al.		6,814,403 B2	11/2004	Zheng	
5,320,404 A	6/1994	Le Gal		6,817,661 B2	11/2004	Zheng	
5,335,967 A	8/1994	Vanderminde, Sr.		6,817,671 B1	11/2004	Zheng	
5,494,333 A	2/1996	Wilson		6,820,927 B2	11/2004	Isom et al.	
5,496,094 A *	3/1996	Schwartzkopf et al.	297/45	6,824,207 B1	11/2004	Lin	
5,499,857 A	3/1996	Lynch, Jr.		6,824,208 B2	11/2004	Zheng	
5,522,642 A	6/1996	Herzog		6,824,210 B2	11/2004	Zheng	
5,580,129 A	12/1996	Findlay		D499,258 S	12/2004	Tseng	
D380,306 S	7/1997	Lin		D500,605 S	1/2005	Schmidt et al.	
D382,126 S	8/1997	Lee		6,840,573 B1	1/2005	Yao	
D382,414 S	8/1997	Lee		6,840,574 B1	1/2005	Wu	
5,718,473 A	2/1998	Lynch, Jr.		6,848,740 B1	2/2005	Reese	
5,848,822 A	12/1998	Wu		D503,554 S	4/2005	Kay	
5,893,605 A	4/1999	Chang		6,877,814 B2	4/2005	Lin	
D411,387 S	6/1999	Zheng		6,883,862 B1	4/2005	Yao	
5,979,976 A	11/1999	Ferencik		6,899,383 B2	5/2005	Hwang	
5,984,406 A	11/1999	Lee		D507,892 S	8/2005	Zheng	
6,045,177 A	4/2000	Grace		6,926,355 B2	8/2005	Le Gette et al.	
6,056,354 A	5/2000	Tseng		6,926,356 B2	8/2005	Chen	
6,082,813 A	7/2000	Chen		6,938,951 B1 *	9/2005	Tseng	297/16.1
6,095,607 A	8/2000	Wenzel		6,957,852 B1	10/2005	Hsieh	
6,112,757 A	9/2000	Tseng		D515,830 S	2/2006	Zheng	
D431,382 S	10/2000	Eloge et al.		6,997,634 B2	2/2006	Zheng	
D432,325 S	10/2000	Zheng et al.		7,000,983 B1	2/2006	Tsai	
D432,823 S	10/2000	Zheng		D516,825 S	3/2006	Zheng	
				D516,826 S	3/2006	Zheng	
				D517,819 S	3/2006	Zheng	
				7,011,372 B1	3/2006	Hsieh	
				7,017,985 B2	3/2006	Chen	

(56)

References Cited

U.S. PATENT DOCUMENTS

D522,263 S 6/2006 Hart
 7,073,852 B1 7/2006 Zheng
 D528,317 S 9/2006 Tseng
 7,100,877 B2 9/2006 Bourke et al.
 7,100,975 B1 9/2006 Zheng
 D529,304 S 10/2006 Le Gal
 D529,728 S 10/2006 Le Gal
 7,140,689 B2 11/2006 Zheng
 7,144,078 B2 12/2006 Hsieh
 7,178,864 B2 2/2007 Hsieh
 7,219,955 B2 5/2007 Lu et al.
 7,229,128 B2 6/2007 Lee
 7,229,131 B2 6/2007 Chen
 7,264,245 B2 9/2007 Cho
 D554,873 S 11/2007 Ma
 D555,378 S 11/2007 Tsai
 7,328,940 B2 2/2008 Zheng
 7,396,073 B2 7/2008 Zheng
 7,404,601 B2 7/2008 Chen
 7,441,287 B2 10/2008 Zheng
 7,600,810 B2 10/2009 Chen et al.
 D608,104 S 1/2010 Vonnegut
 7,648,421 B2 1/2010 Yoon
 7,938,489 B2 5/2011 Nazari
 D649,800 S 12/2011 Lievore et al.
 D656,326 S 3/2012 Soewondo
 D661,360 S 6/2012 Campanaro et al.
 8,282,509 B1 10/2012 Michaelson et al.
 D677,920 S 3/2013 Christakos
 D681,970 S 5/2013 Christakos
 D683,156 S 5/2013 Christakos
 D688,057 S 8/2013 Christakos
 D691,384 S 10/2013 Akkad
 D703,460 S * 4/2014 Kreuzer et al. D6/368
 D711,151 S 8/2014 Christakos
 2002/0024240 A1 2/2002 Chen
 2002/0043822 A1 4/2002 Choi
 2002/0074834 A1 6/2002 Summar et al.
 2002/0183128 A1 12/2002 Cho
 2003/0006632 A1 1/2003 Ku
 2003/0015892 A1 1/2003 Wu
 2003/0020304 A1 1/2003 Zheng
 2003/0052518 A1 3/2003 Zheng
 2003/0057741 A1 3/2003 Zheng
 2003/0057747 A1 3/2003 Johnston
 2003/0060309 A1 3/2003 Smith
 2003/0094836 A1 5/2003 Chen
 2003/0111872 A1 6/2003 Zheng
 2003/0111874 A1 6/2003 Zheng
 2003/0127885 A1 7/2003 Tang
 2003/0234561 A1 12/2003 Zheng
 2004/0007903 A1 1/2004 Chang
 2004/0036323 A1 2/2004 Hwang
 2004/0066075 A1 4/2004 Yeh
 2004/0094996 A1 5/2004 Zheng
 2004/0094997 A1 5/2004 Zheng
 2004/0113476 A1 6/2004 Chang
 2004/0130190 A1 7/2004 Zheng
 2004/0135405 A1 7/2004 Zheng
 2004/0232740 A1 11/2004 Enge

2004/0245810 A1 12/2004 Tseng
 2005/0077758 A1 4/2005 Reese
 2005/0088018 A1 4/2005 Yao
 2005/0236873 A1 10/2005 Edward
 2005/0248202 A1 11/2005 Zheng
 2006/0186711 A1 8/2006 Phipps
 2007/0029846 A1 2/2007 Cohen
 2007/0102974 A1 5/2007 Chen
 2007/0187998 A1 8/2007 Chen
 2007/0200395 A1 8/2007 Zheng
 2007/0267901 A1 11/2007 Zheng
 2008/0224504 A1 9/2008 Fargason
 2008/0231088 A1 9/2008 Zheng
 2010/0164256 A1 7/2010 Salisbury
 2010/0231015 A1 9/2010 Lundeen

FOREIGN PATENT DOCUMENTS

CN 2117779 U 10/1992
 CN 2137107 Y 6/1993
 CN 2179041 Y 10/1994
 CN 2188885 Y 2/1995
 CN 2196945 Y 5/1995
 CN 1139537 A 1/1997
 CN 2326083 Y 6/1999
 CN 2328266 Y 7/1999
 CN 2339063 Y 9/1999
 CN 2349884 Y 11/1999
 CN 2367154 Y 3/2000
 EP 139306 A1 5/1985
 EP 997090 A1 5/2000
 FR 2833824 A1 6/2003
 FR 2837081 A1 9/2003
 GB 599760 A 3/1948
 GB 2022405 A 12/1979
 GB 2025213 A 1/1980
 GB 2331233 A 5/1999
 JP 38-12532 6/1938
 JP 50123508 A 9/1975
 JP 51127856 A 11/1976
 JP 55120347 A 9/1980
 JP 2001070077 A 3/2001
 JP 2002165667 A 6/2002
 JP 2002233429 A 8/2002
 JP 2002360371 A 12/2002
 JP 2004105557 A 4/2004
 WO 2004021835 A1 3/2004

OTHER PUBLICATIONS

U.S. Appl. No. 13/570,472 by Akkad, filed Aug. 9, 2012.
 U.S. Appl. No. 29/434,983 by Akkad, filed Oct. 18, 2012.
 Office Action issued Jan. 28, 2014 in CA Application No. 2,791,594.
 Office Action issued Sep. 20, 2013 in U.S. Appl. No. 13/570,472 by Akkad.
 Office Action issued Jan. 14, 2014 in U.S. Appl. No. 13/570,472 by Akkad.
 U.S. Appl. No. 29/483,471 by Akkad, filed Feb. 28, 2014.
 U.S. Appl. No. 29/483,488 by Akkad, filed Feb. 28, 2014.
 U.S. Appl. No. 29/478,866 by Akkad, filed Jan. 9, 2014.
 U.S. Appl. No. 29/493,606 by Akkad, filed Jun. 11, 2014.

* cited by examiner

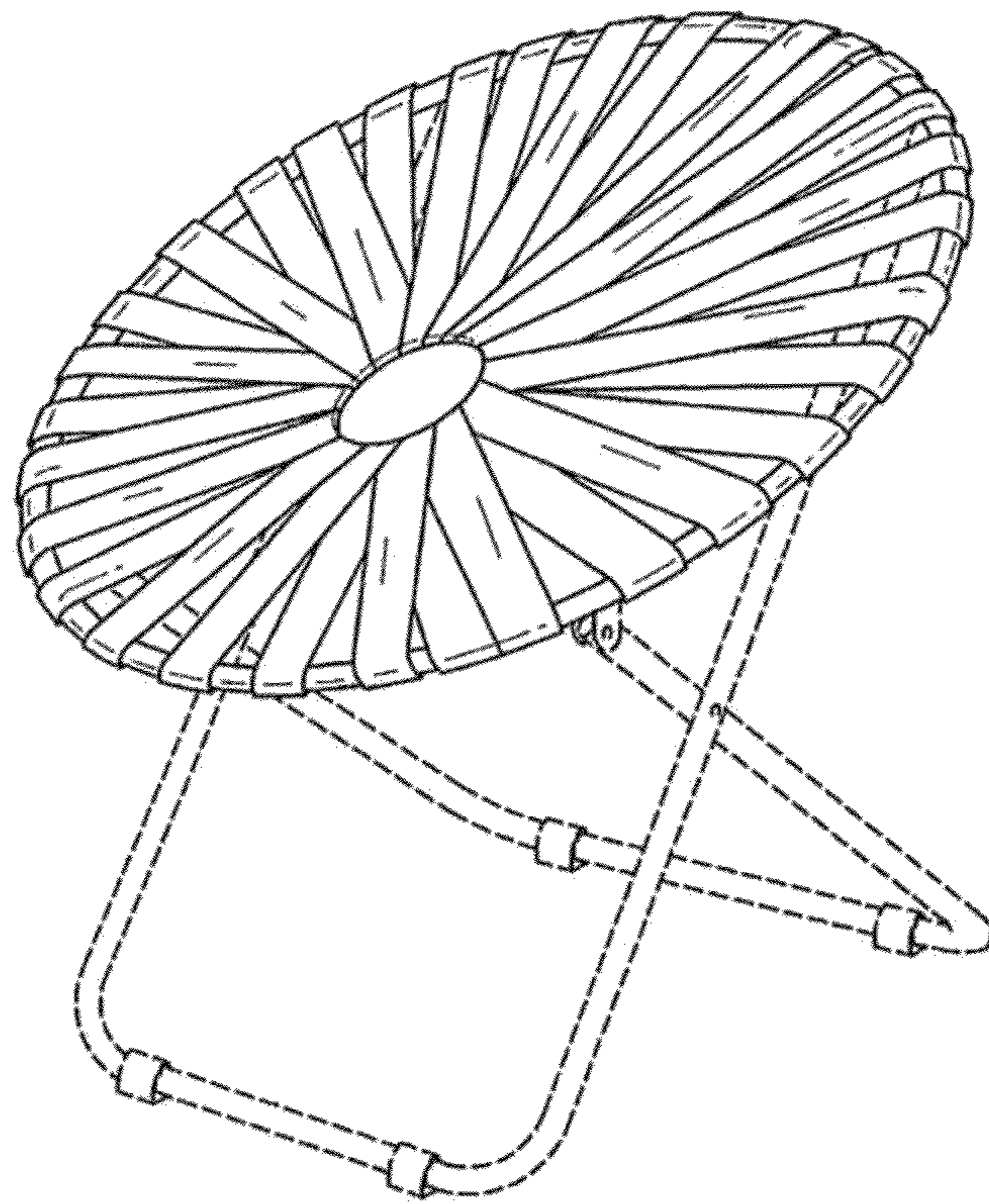

Fig. 1

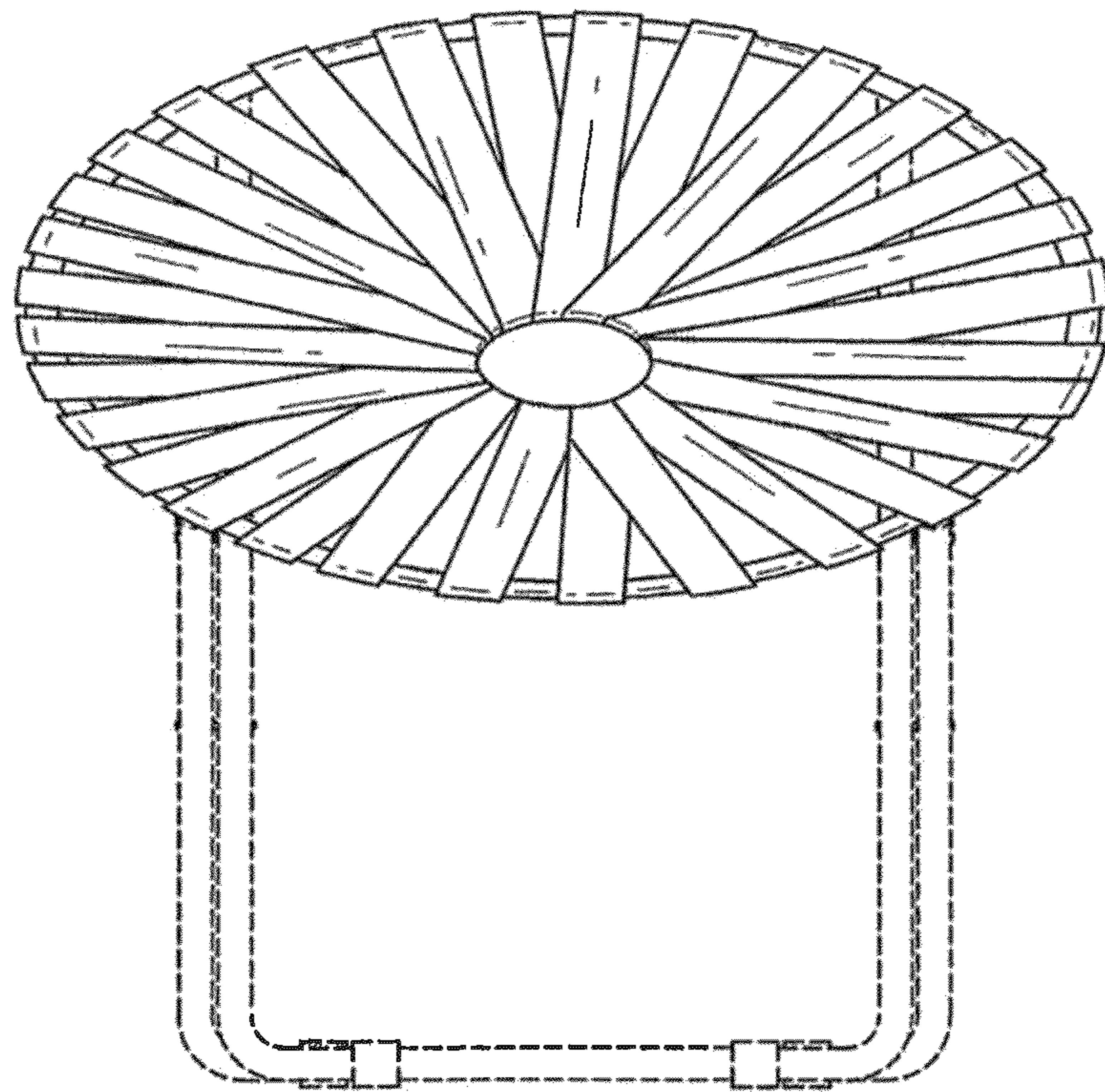

Fig. 2

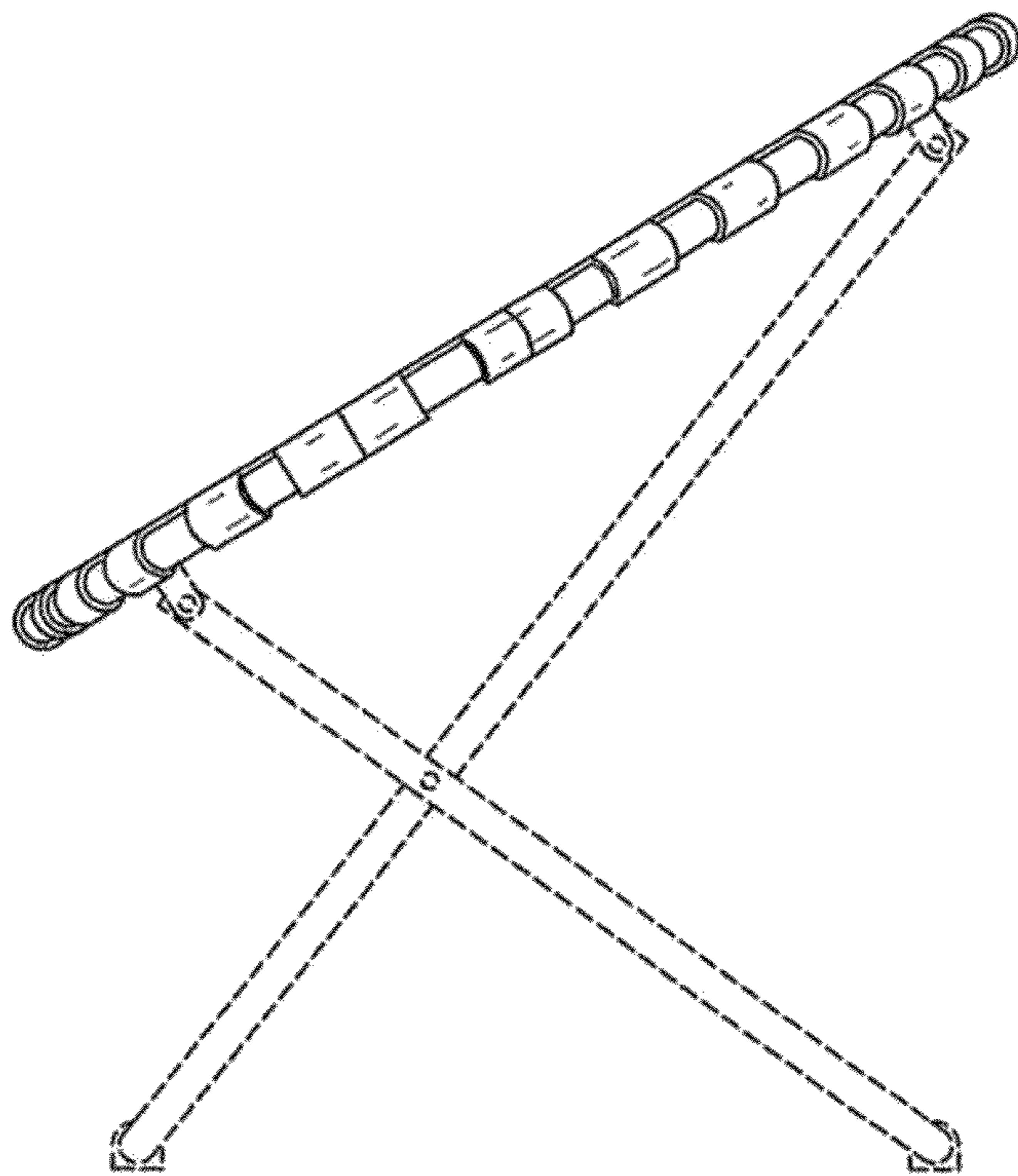

Fig. 3

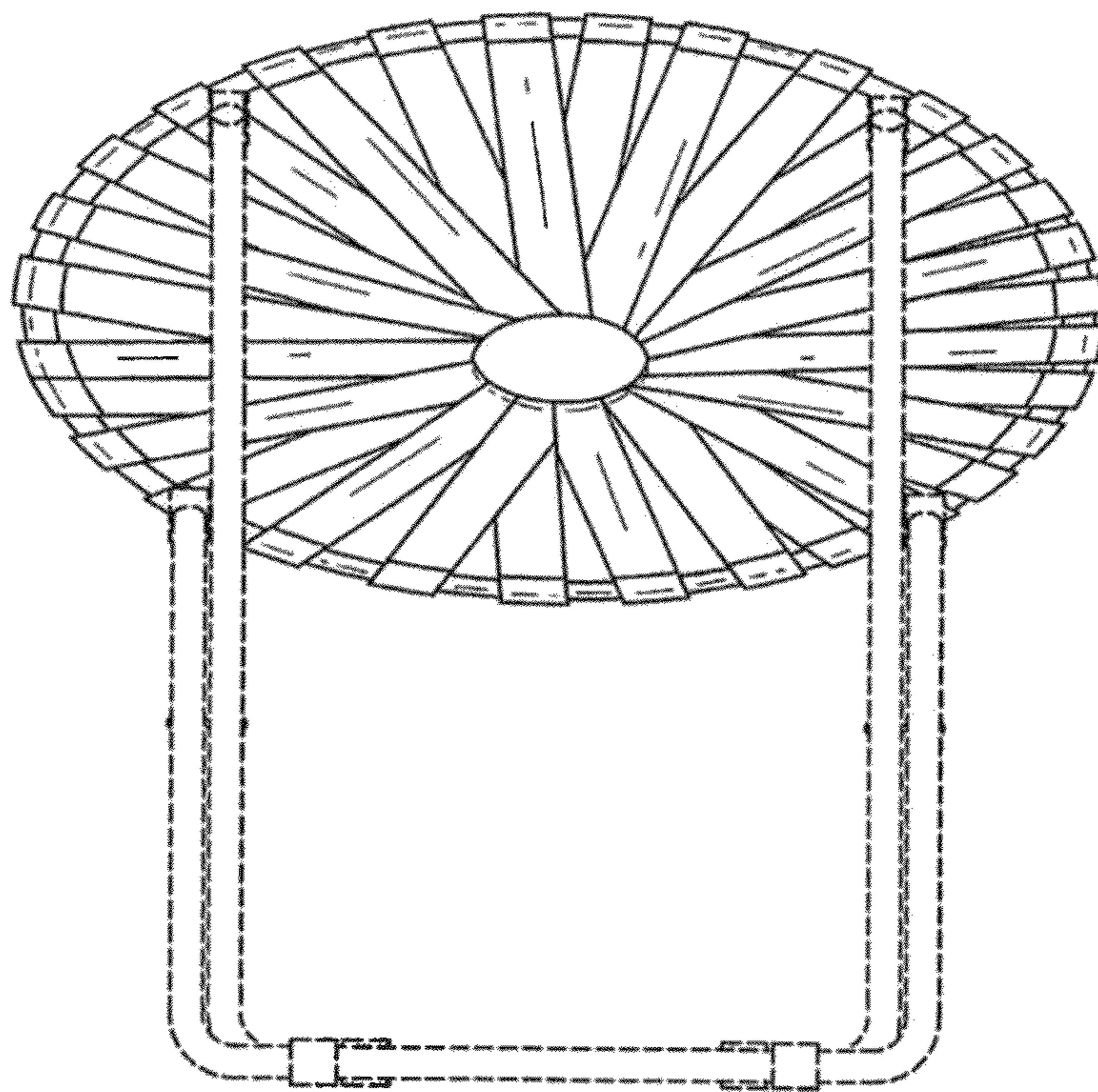

Fig. 4

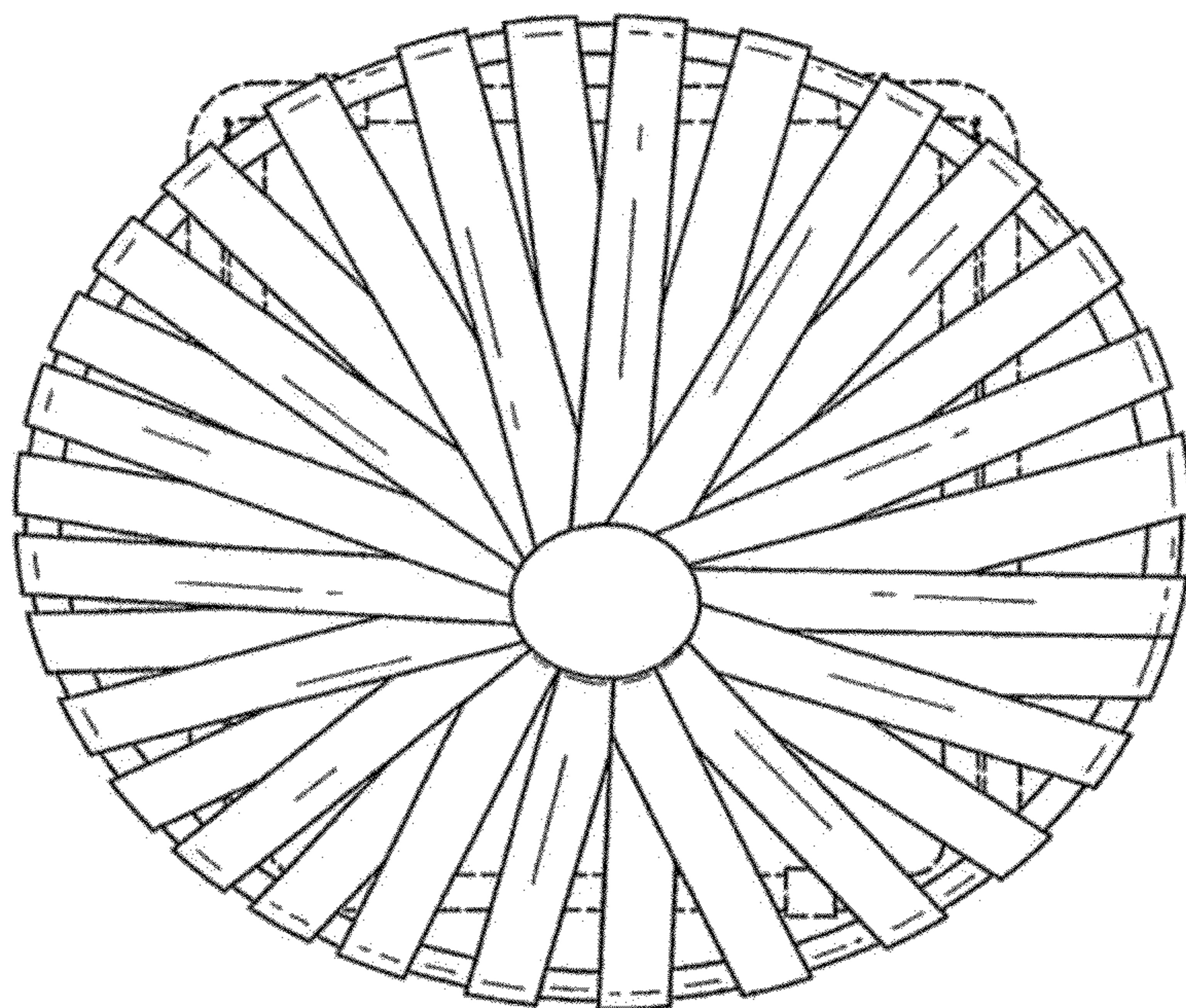

Fig. 5

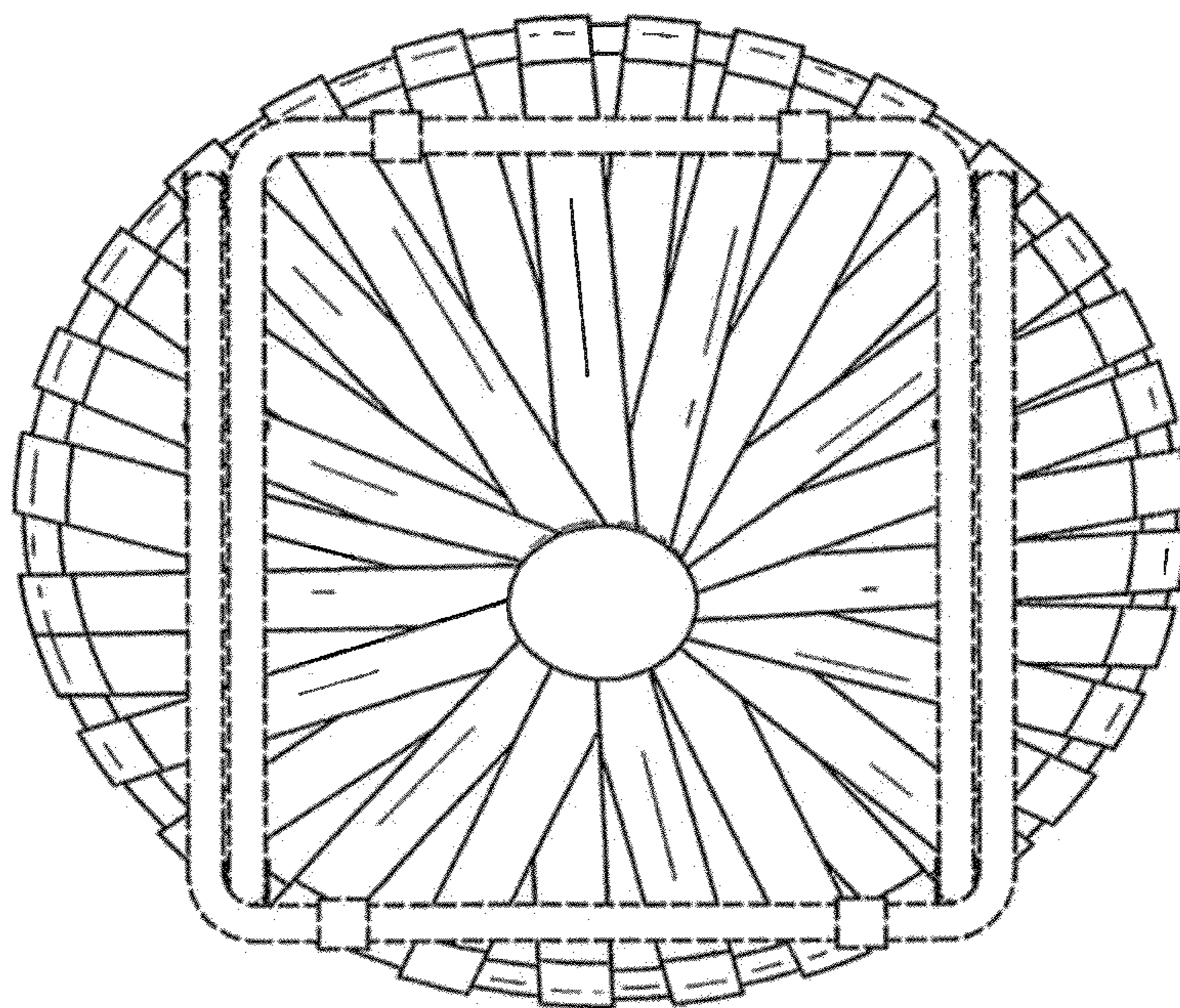

Fig. 6