



US00D718471S

(12) **United States Design Patent**
So et al.

(10) **Patent No.:** **US D718,471 S**

(45) **Date of Patent:** **** Nov. 25, 2014**

(54) **3-DIMENSIONAL LARGE CAPACITY CELL
ENCAPSULATION DEVICE**

(71) Applicant: **ViaCyte, Inc.**, San Diego, CA (US)

(72) Inventors: **Vincent So**, San Diego, CA (US); **Laura
Martinson**, San Diego, CA (US); **Chad
Green**, San Diego, CA (US); **Michael
Scott**, San Diego, CA (US)

(73) Assignee: **ViaCyte, Inc.**, San Diego, CA (US)

(**) Term: **14 Years**

(21) Appl. No.: **29/484,360**

(22) Filed: **Mar. 7, 2014**

(51) **LOC (10) Cl.** **24-02**

(52) **U.S. Cl.**
USPC **D24/224**

(58) **Field of Classification Search**
USPC D24/216, 222, 224-232; 422/63-67,
422/99-104, 509, 552, 553, 549, 569, 400,
422/423, 488; D23/330, 358; D13/179;
D1/199; D30/160; D7/701, 387;
D25/123; 210/638; 435/29, 177, 371,
435/325; 623/1.41, 23.72; 141/327;
424/422, 424; 604/891.1

See application file for complete search history.

(56) **References Cited**

U.S. PATENT DOCUMENTS

D254,506 S *	3/1980	Holmberg	D23/358
D270,092 S *	8/1983	Lacasse	D25/123
D278,140 S *	3/1985	Tatum	D13/179
D300,293 S *	3/1989	Casey	D7/387
D353,747 S *	12/1994	Lanier	D7/701
5,980,889 A *	11/1999	Butler et al.	435/177
6,068,775 A *	5/2000	Custer et al.	210/638
D453,977 S *	2/2002	Park et al.	D30/160
D473,318 S *	4/2003	Barbera-Guillem	D24/225
D485,241 S *	1/2004	Lee	D13/179
D536,774 S *	2/2007	Kuo et al.	D23/330

D619,232 S *	7/2010	Ragaini	D23/330
D632,799 S *	2/2011	Canner et al.	D24/216
8,278,106 B2 *	10/2012	Martinson et al.	435/371
D676,118 S *	2/2013	Hansen	D23/330
8,414,925 B2 *	4/2013	Freier	424/488
D692,578 S *	10/2013	Kikuhara et al.	D24/216
D706,017 S *	6/2014	King et al.	D1/199
2009/0068170 A1 *	3/2009	Weitz et al.	435/29
2009/0105811 A1 *	4/2009	Dinh et al.	623/1.41

* cited by examiner

Primary Examiner — T. Chase Nelson

Assistant Examiner — Mark Cavanna

(74) *Attorney, Agent, or Firm* — Kilpatrick Townsend & Stockton LLP

(57) **CLAIM**

The ornamental design for a 3-dimensional large capacity cell encapsulation device, as shown and described.

DESCRIPTION

FIG. 1 is a perspective view of the 3-dimensional large capacity cell encapsulation device with a single cell chamber and port.

FIG. 2 is a back elevation view of the 3-dimensional large capacity cell encapsulation device with a single cell chamber and port.

FIG. 3 is a front elevation view of the 3-dimensional large capacity cell encapsulation device with a single cell chamber and port.

FIG. 4 is a top plan view of the 3-dimensional large capacity cell encapsulation device with a single cell chamber and port.

FIG. 5 is a bottom plan view of the 3-dimensional large capacity cell encapsulation device with a single cell chamber and port.

FIG. 6 is a right elevation view of the 3-dimensional large capacity cell encapsulation device with a single cell chamber and port; and,

FIG. 7 is a left elevation view of the 3-dimensional large capacity cell encapsulation device with a single cell chamber and port.

1 Claim, 3 Drawing Sheets

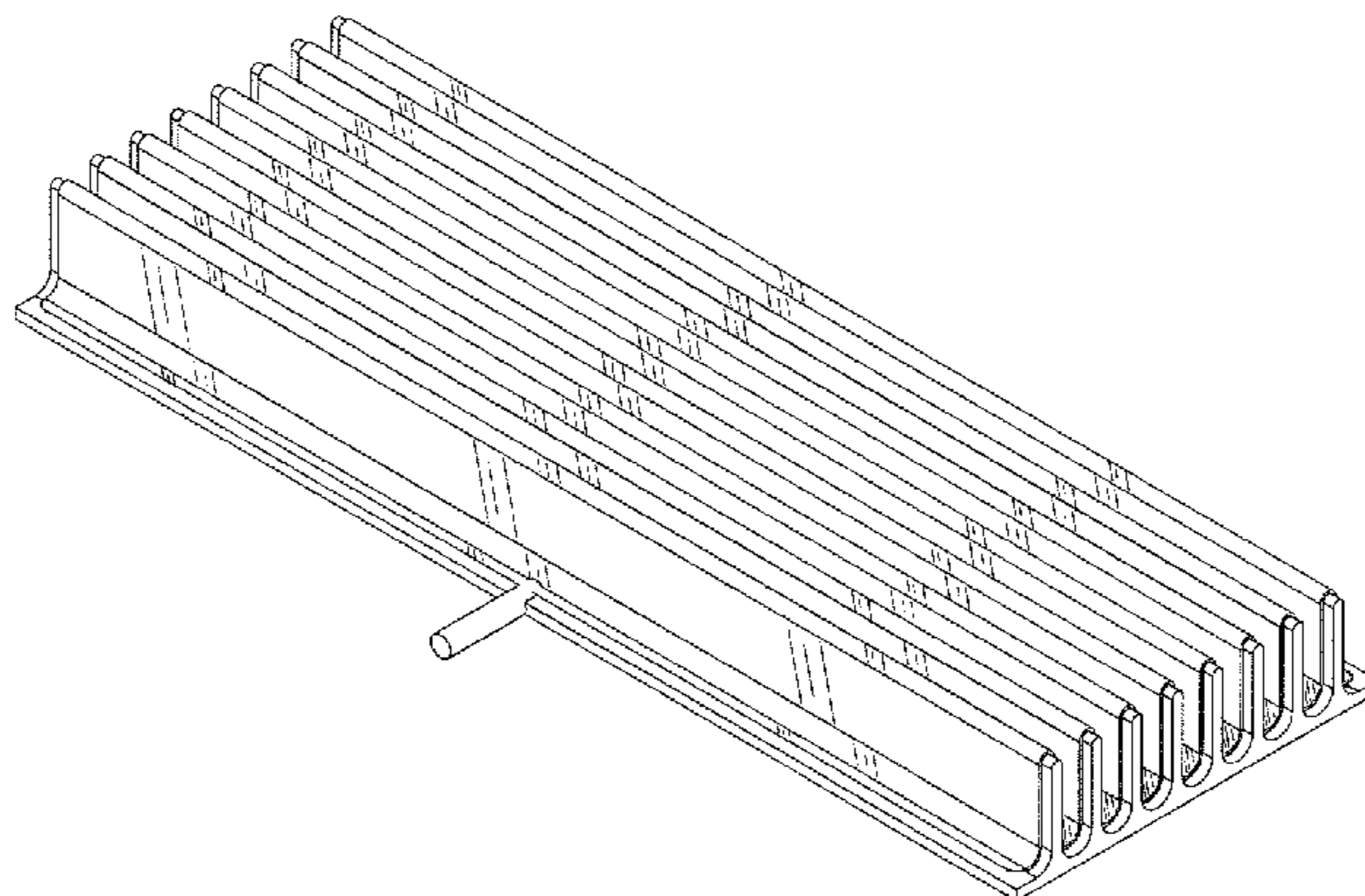

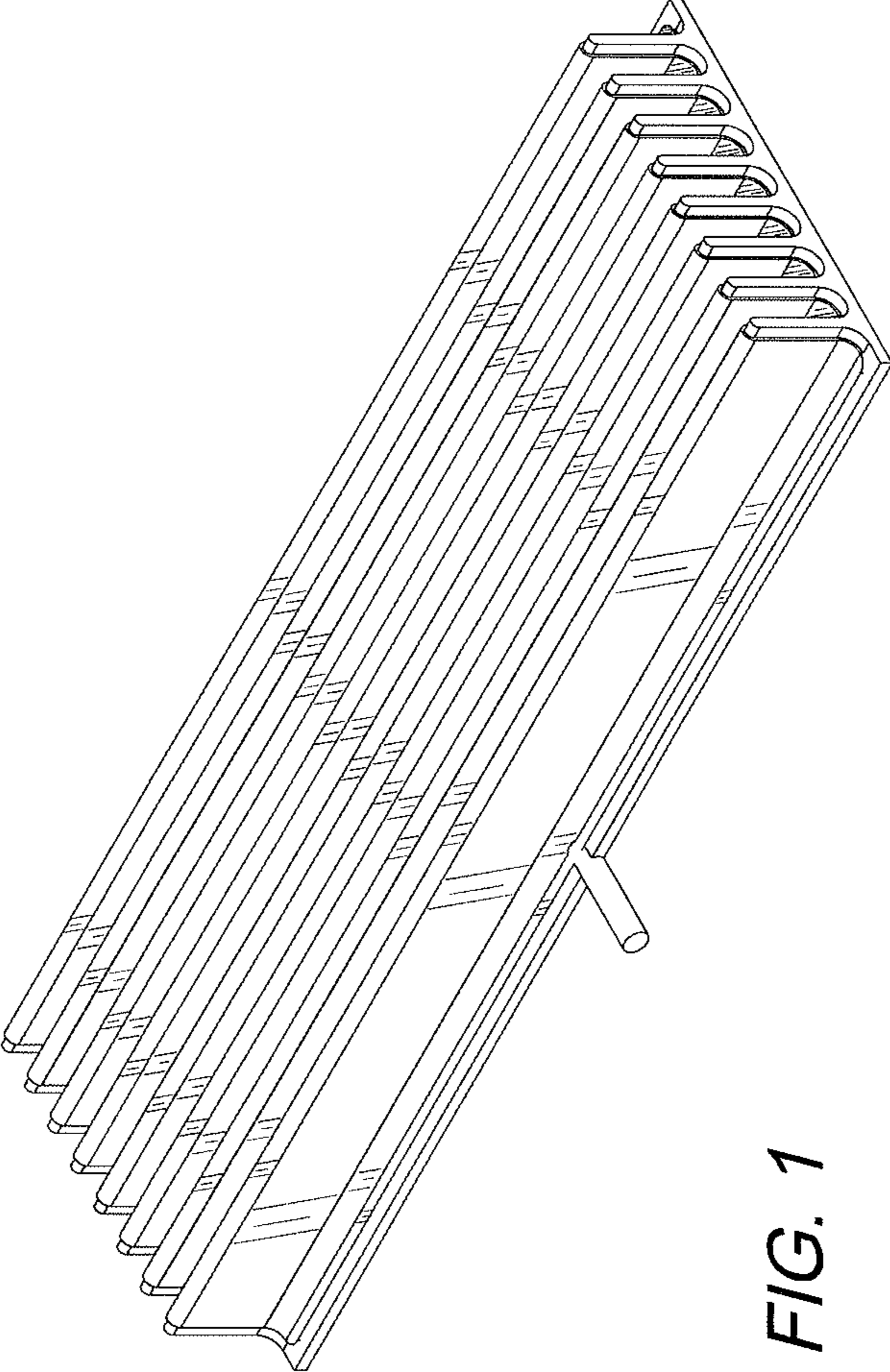

FIG. 1

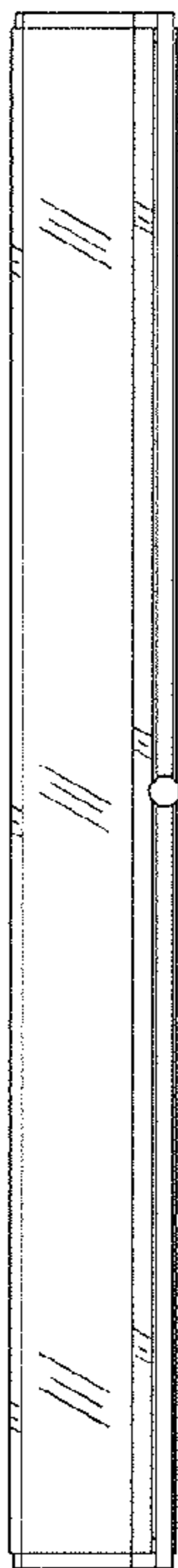

FIG. 3

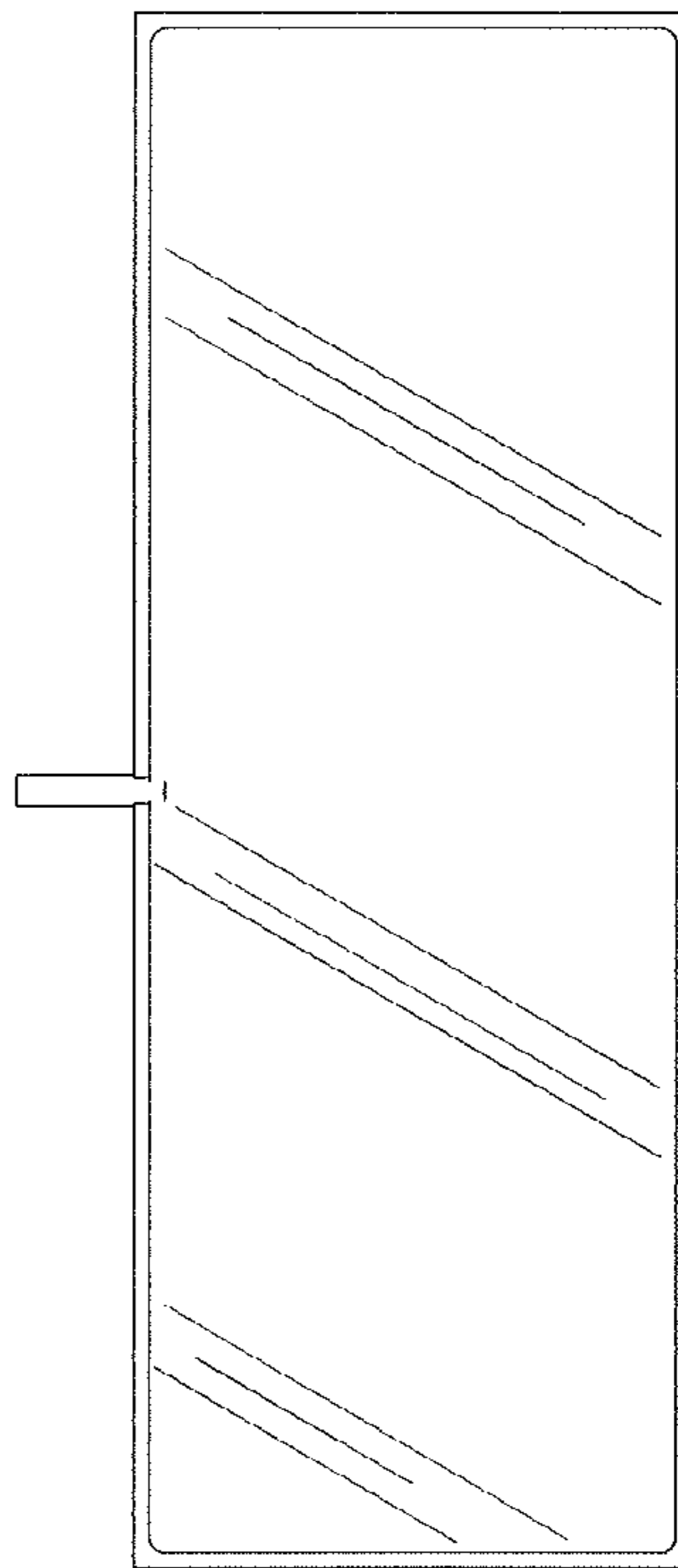

FIG. 5

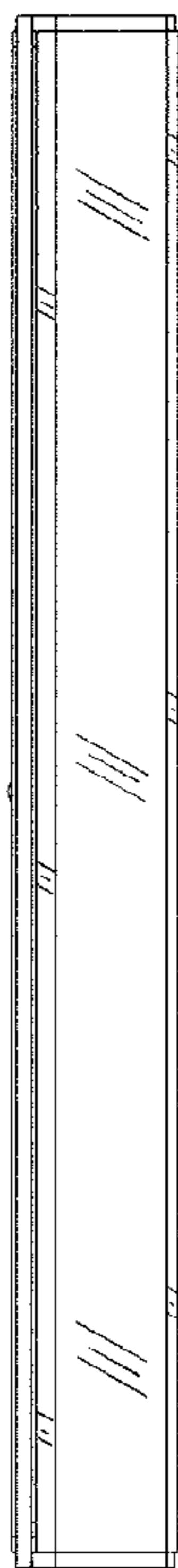

FIG. 2

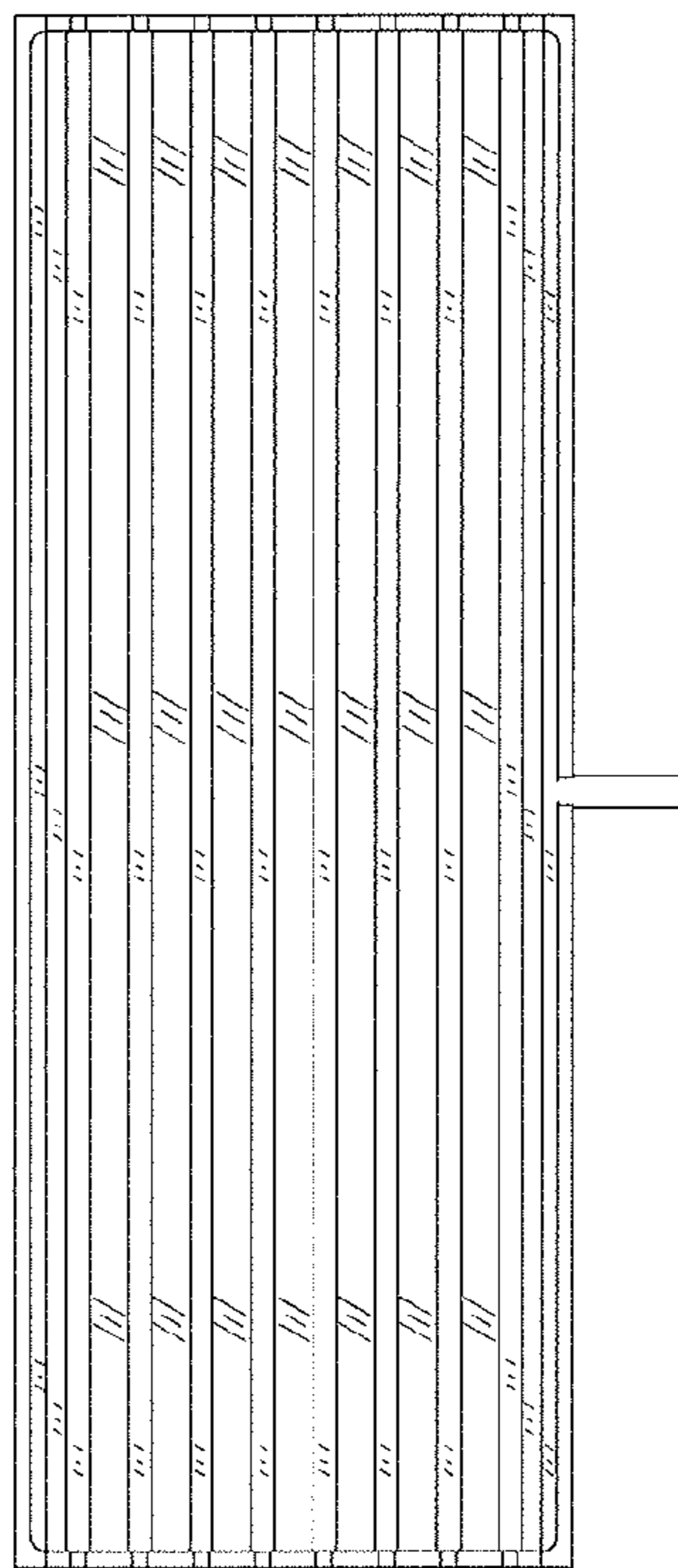

FIG. 4

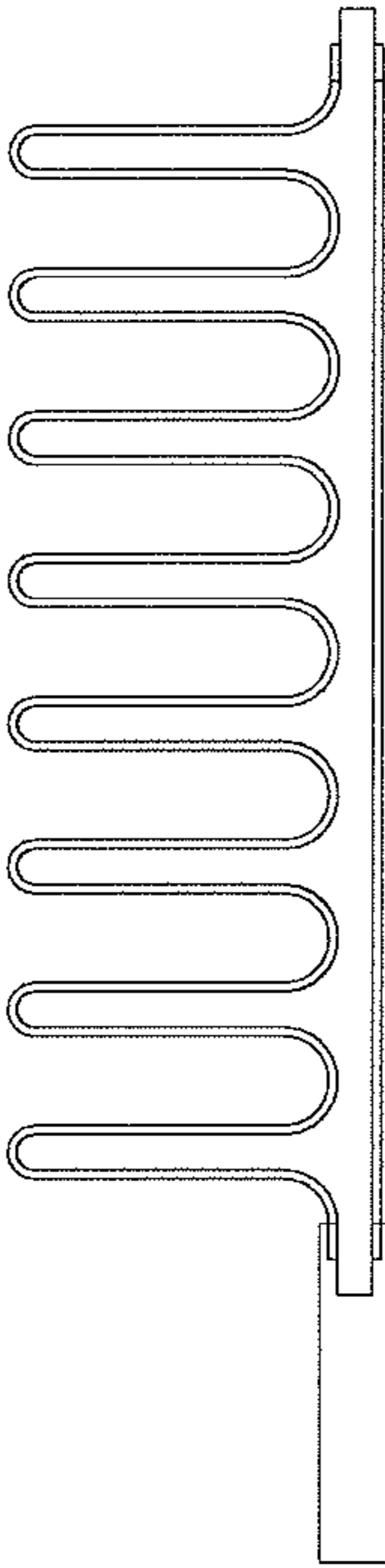

FIG. 6

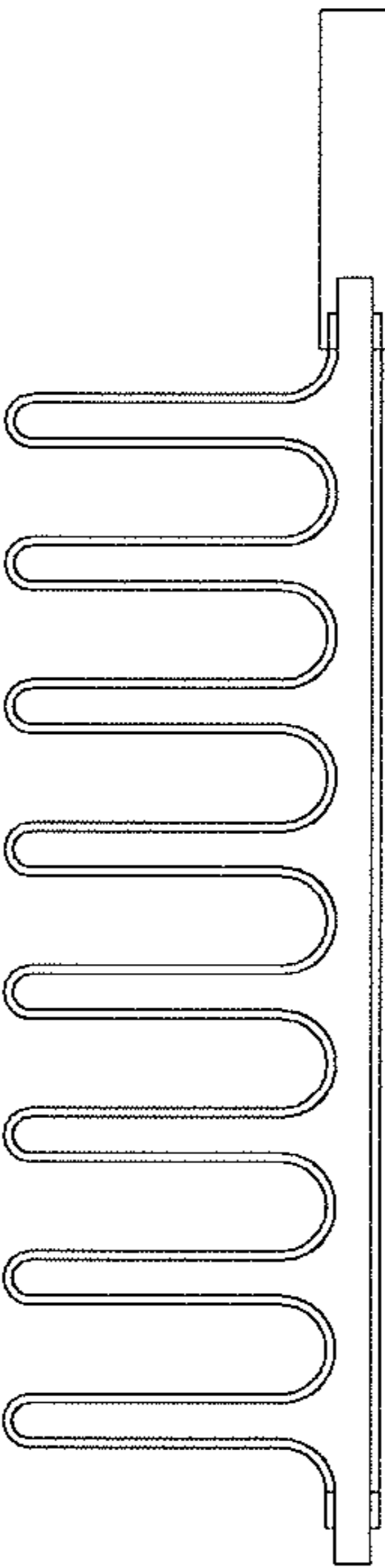

FIG. 7