



US00D718419S

(12) **United States Design Patent**
Borg et al.

(10) **Patent No.:** **US D718,419 S**
(45) **Date of Patent:** **** Nov. 25, 2014**

(54) **FLOW CONTROL AND INDICATOR ASSEMBLY**

FOREIGN PATENT DOCUMENTS

WO 2014035852 3/2014

(71) Applicant: **Zodiac Pool Systems, Inc.**, Vista, CA (US)

OTHER PUBLICATIONS

(72) Inventors: **Dustin Borg**, Poway, CA (US); **Mark Bauckman**, San Marcos, CA (US); **Kevin Braidic**, Carlsbad, CA (US)

International Search Report and Written Opinion dated Nov. 18, 2013 in Application No. PCT/US2013/056566.

* cited by examiner

(73) Assignee: **Zodiac Pool Systems, Inc.**, Vista, CA (US)

Primary Examiner — Cynthia Ramirez

(74) *Attorney, Agent, or Firm* — Dean W. Russell; Michael A. Bertelson; Kilpatrick Townsend & Stockton LLP

(**) Term: **14 Years**

(57) **CLAIM**

The ornamental design for a flow control and indicator assembly, as shown and described.

(21) Appl. No.: **29/463,361**

DESCRIPTION

(22) Filed: **Oct. 28, 2013**

(51) **LOC (10) Cl.** **23-01**

(52) **U.S. Cl.**
USPC **D23/233**

(58) **Field of Classification Search**
USPC D23/233–237, 244–249; 137/114, 269, 137/605, 907, 495, 327
See application file for complete search history.

FIG. 1 is an isometric view of a flow control and indicator assembly.

FIG. 2 is another isometric view of the flow control and indicator assembly of FIG. 1.

FIG. 3 is a front view of the flow control and indicator assembly of FIG. 1.

FIG. 4 is a right side view of the flow control and indicator assembly of FIG. 1, the left side view being a mirror image of the right side view.

FIG. 5 is a rear view of the flow control and indicator assembly of FIG. 1; and,

FIG. 6 is a top view of the flow control and indicator assembly of FIG. 1, the bottom view being a mirror image of the top view.

The broken line showing in the figures is included for the purpose of illustrating elements of the flow control and indicator and forms no part of the claimed design.

(56) **References Cited**

U.S. PATENT DOCUMENTS

D325,621	S *	4/1992	Hengesbach	D23/245
5,720,068	A	2/1998	Clark et al.		
D404,118	S *	1/1999	Hwang	D23/233
D409,287	S *	5/1999	Hansen	D23/248
6,484,743	B2	11/2002	Bauckman		
D633,179	S *	2/2011	Geideman et al.	D23/233
2011/0226361	A1	9/2011	Van Der Meijden et al.		
2012/0137451	A1	6/2012	Bauckman et al.		
2014/0060671	A1	3/2014	Borg et al.		

1 Claim, 6 Drawing Sheets

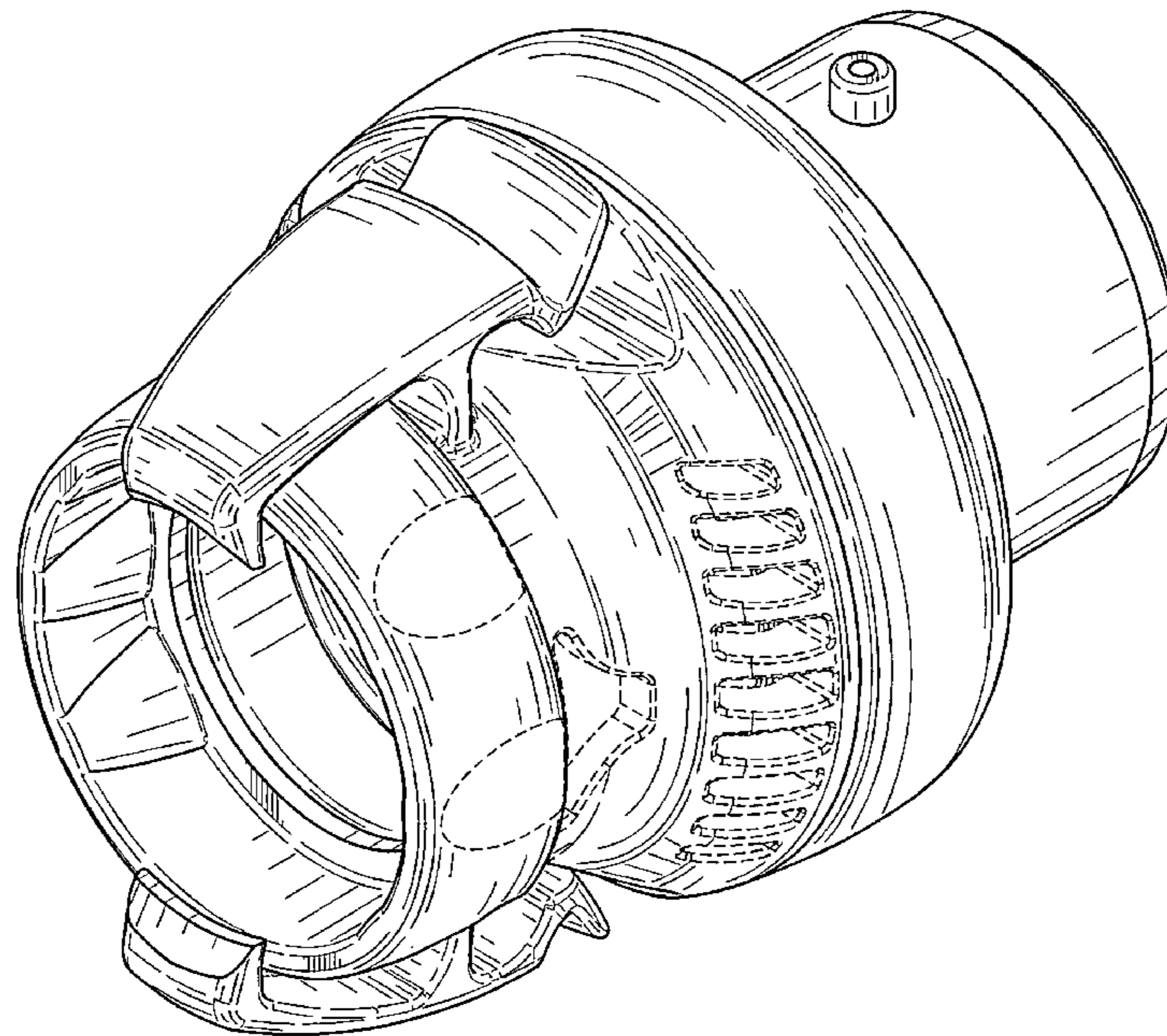

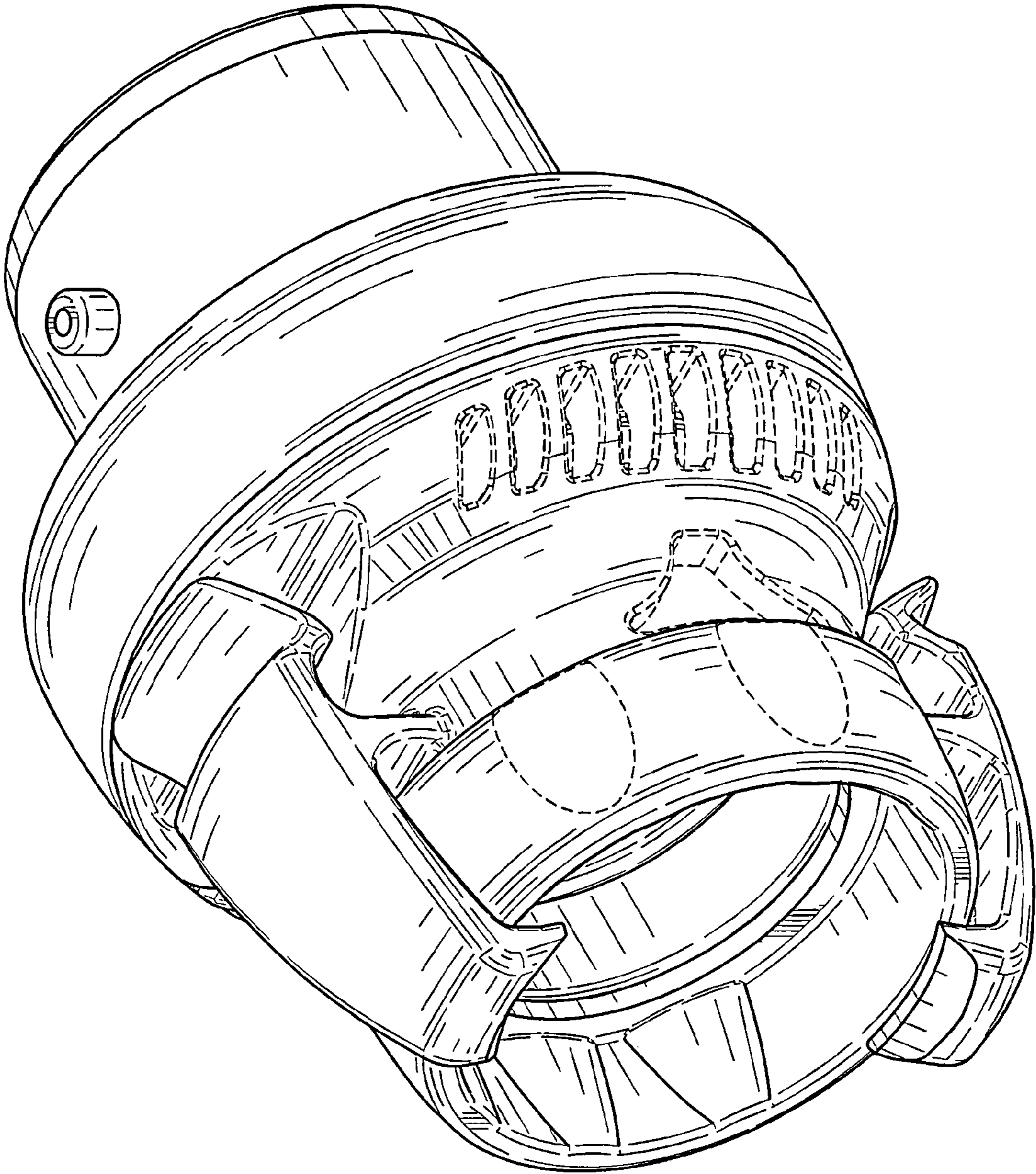

FIG. 1

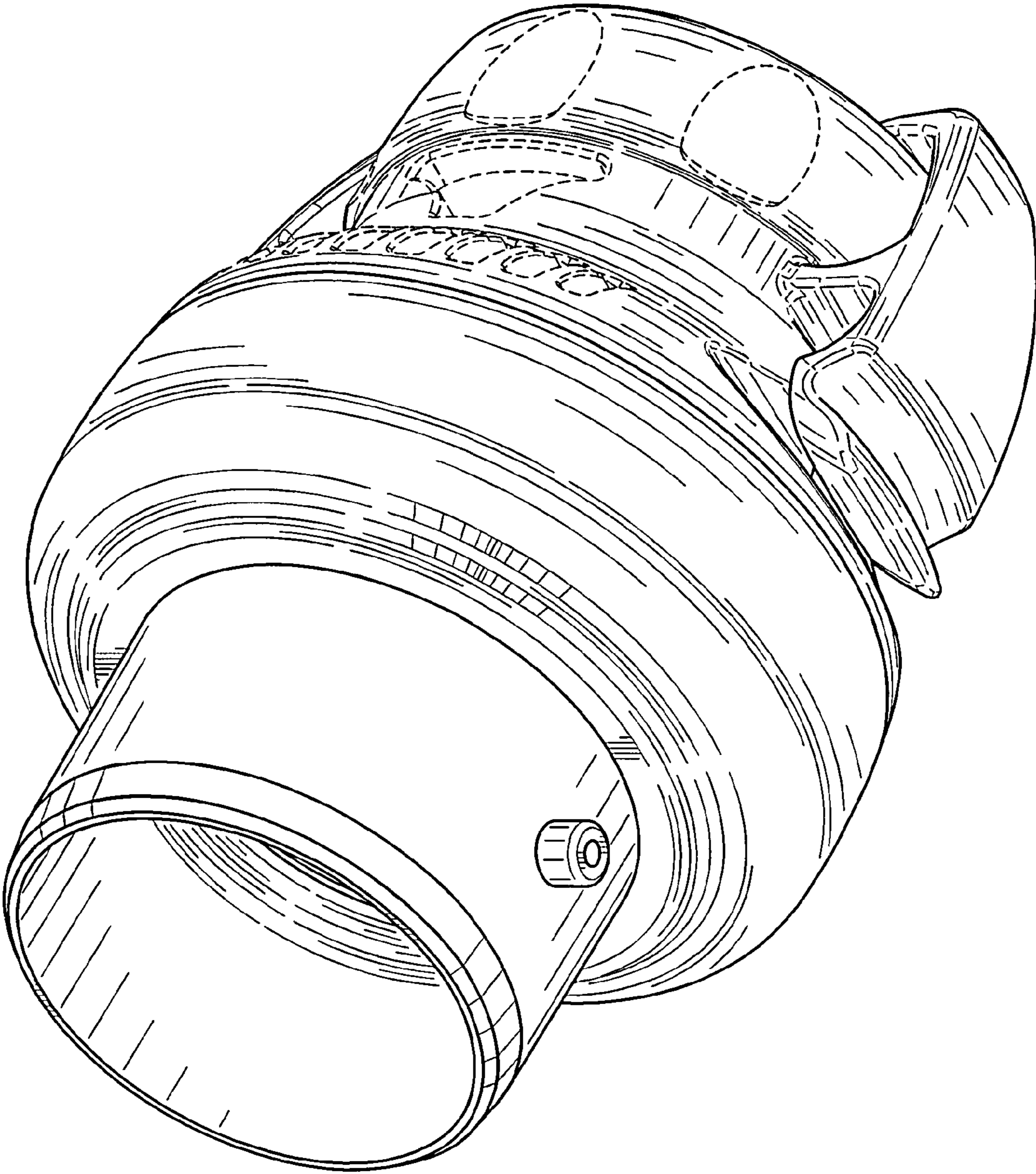

FIG. 2

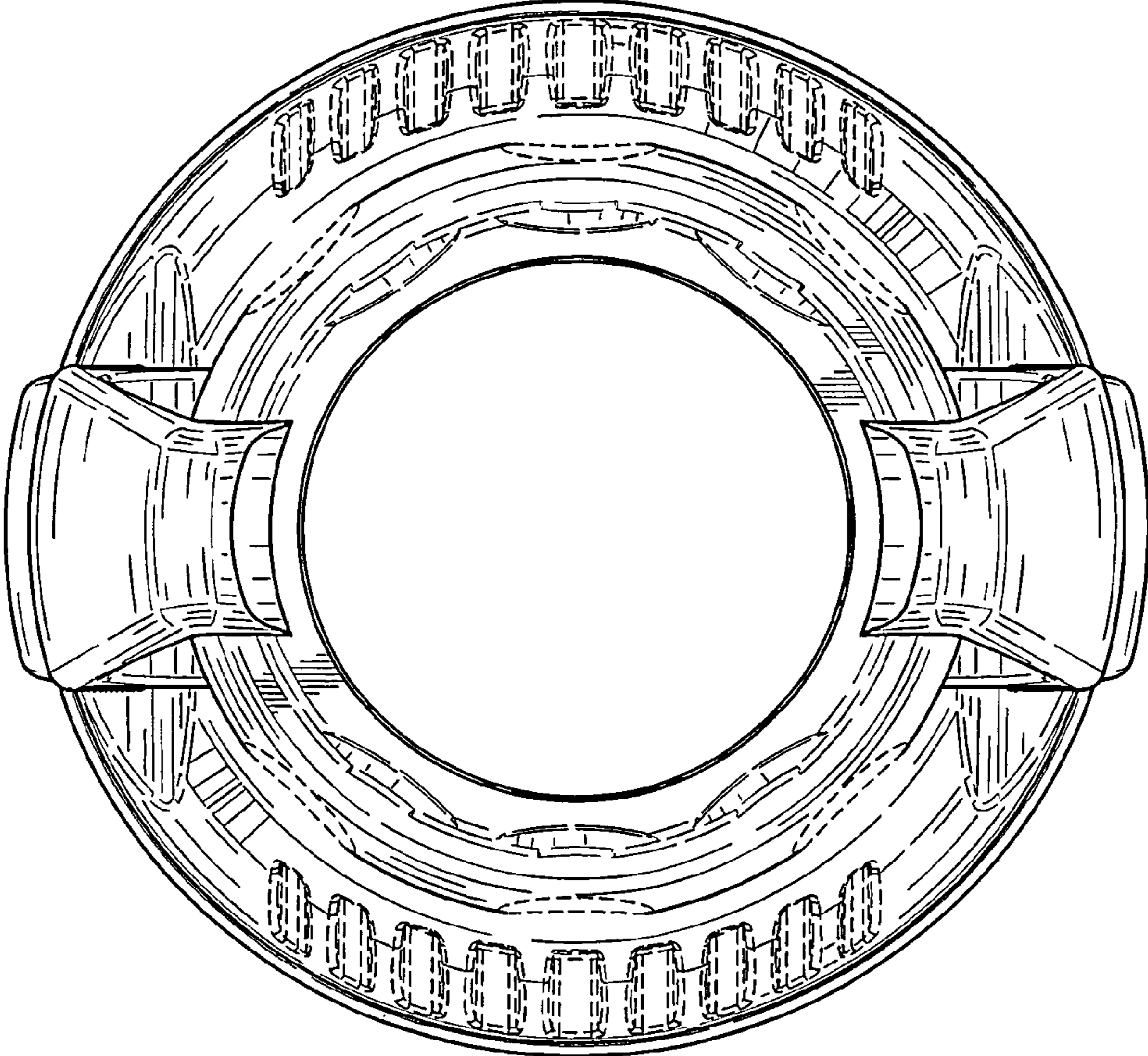

FIG. 3

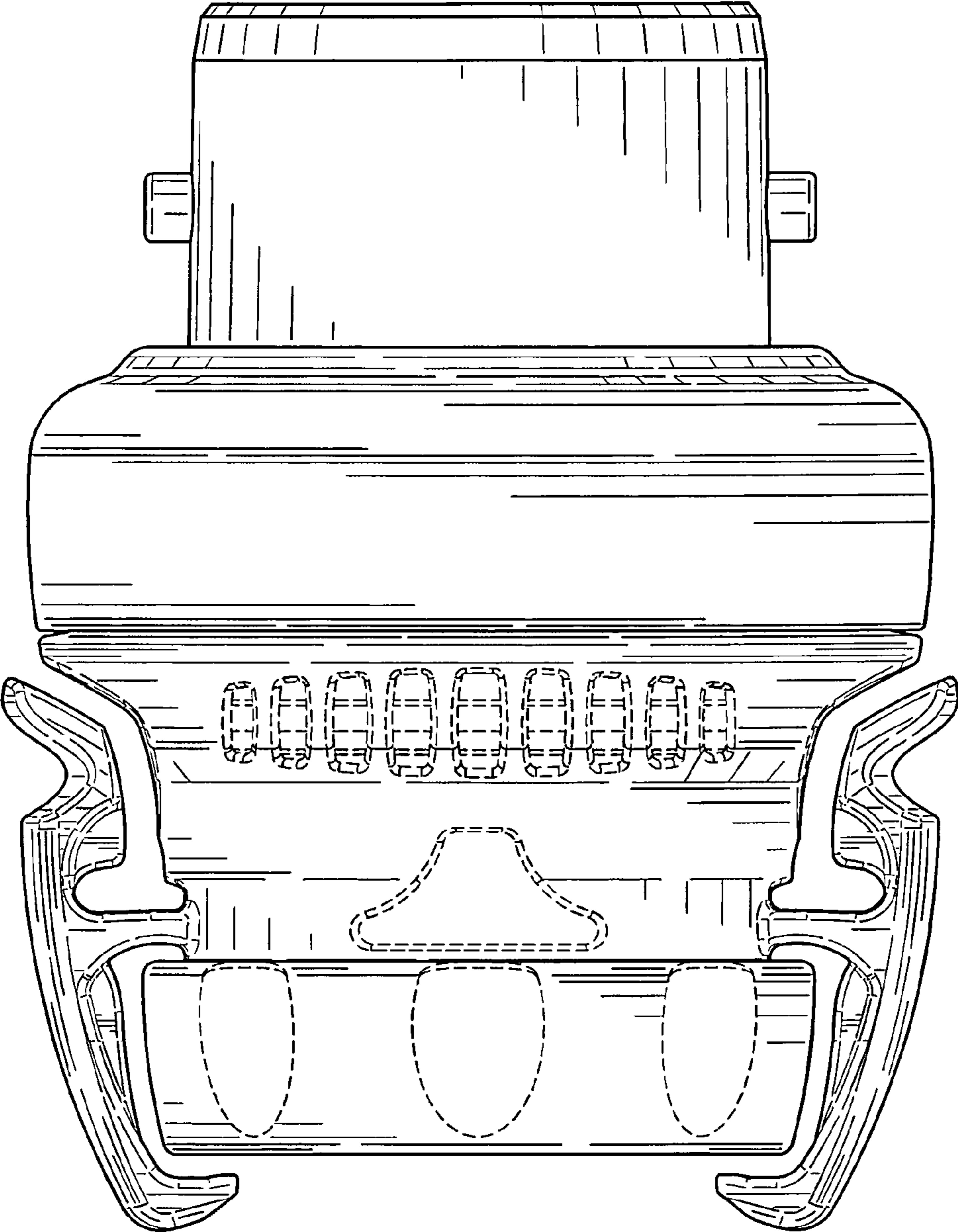

FIG. 4

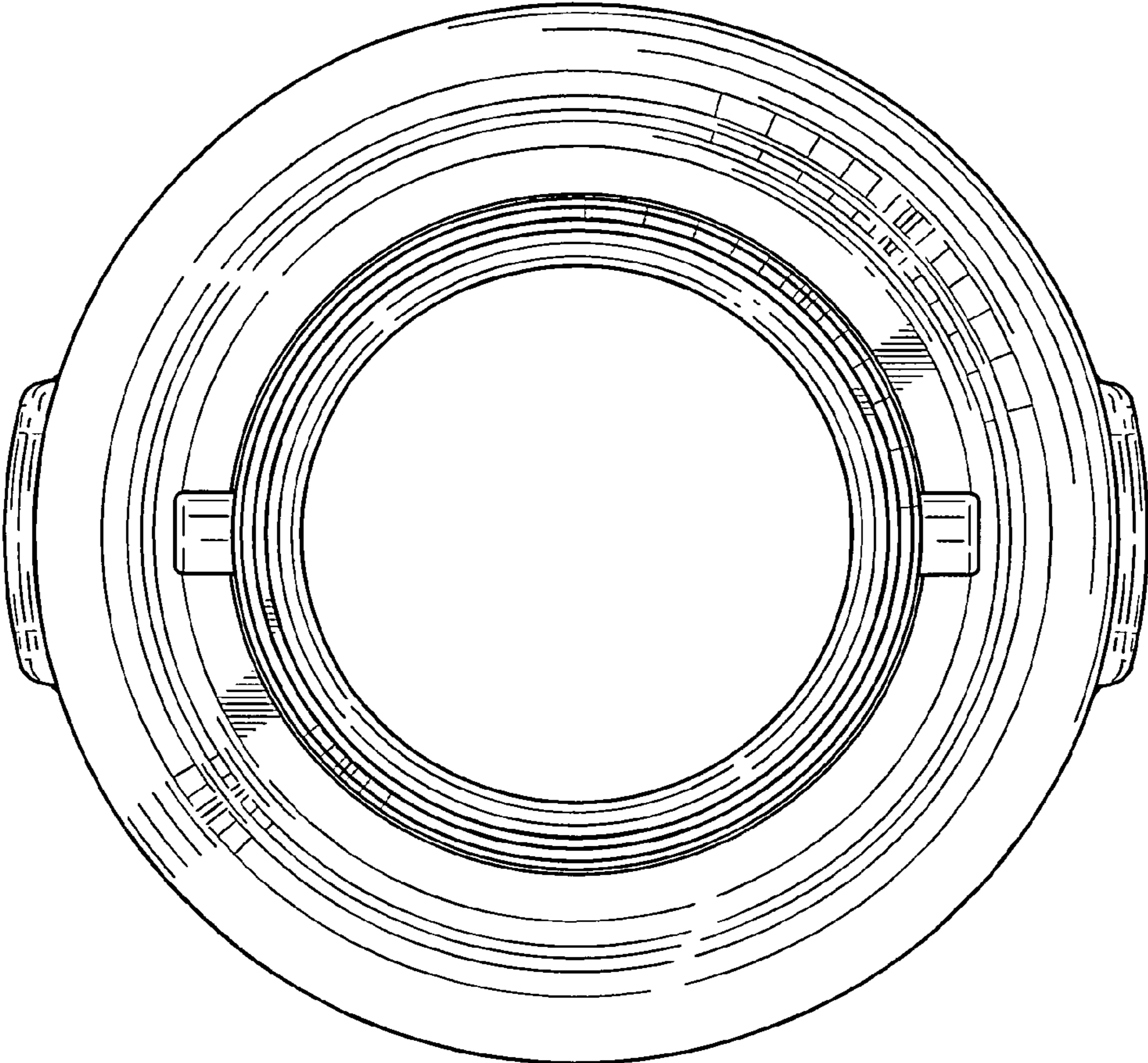

FIG. 5

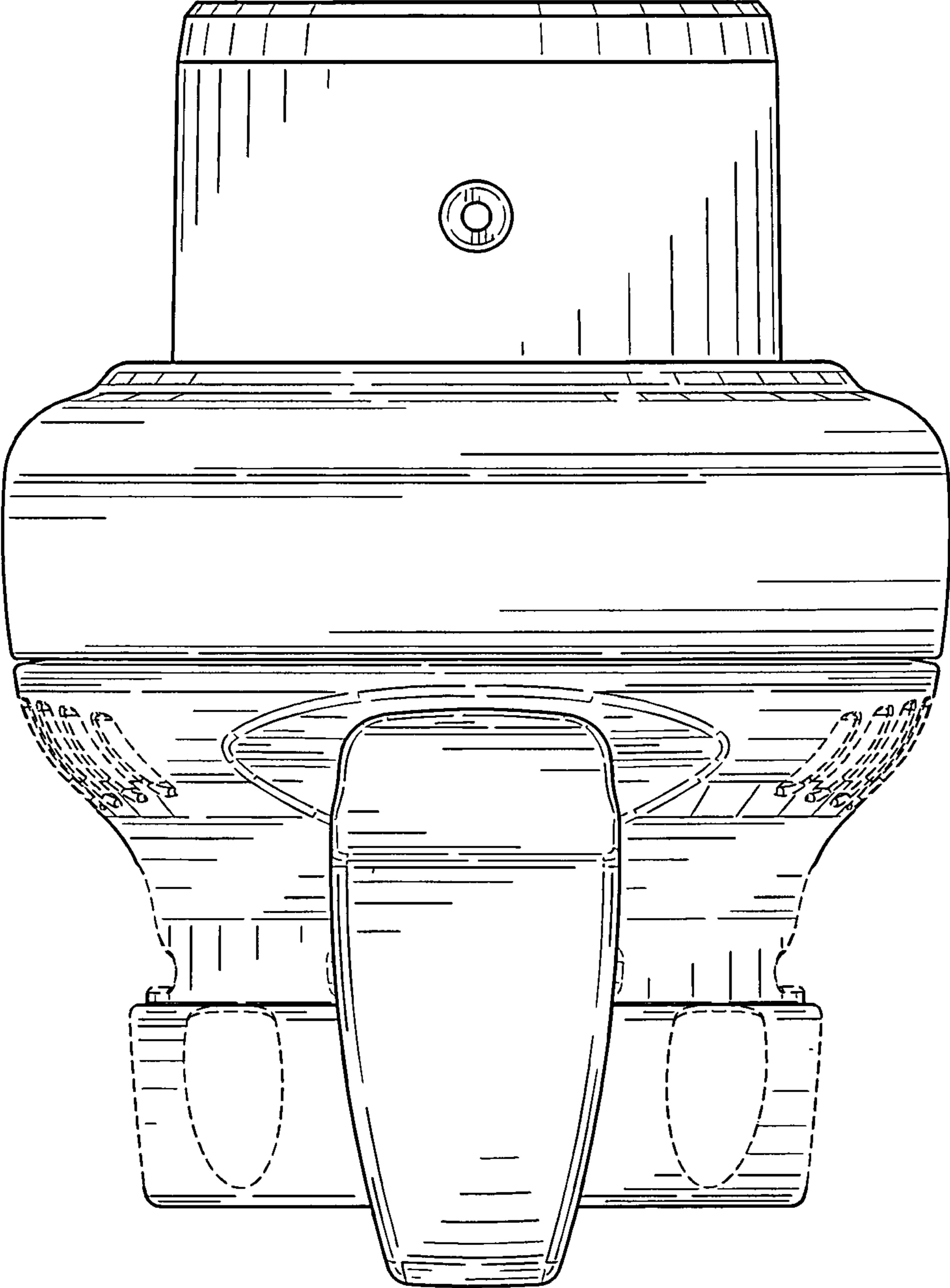

FIG. 6