



US00D718189S

(12) **United States Design Patent**  
**Krieg et al.**

(10) **Patent No.:** **US D718,189 S**

(45) **Date of Patent:** **\*\* Nov. 25, 2014**

(54) **VEHICLE BODY EXTERIOR**  
(71) Applicant: **GM Global Technology Operations LLC**, Detroit, MI (US)  
(72) Inventors: **Robin Krieg**, Bloomfield Hills, MI (US); **Brian J. Smith**, Farmington Hills, MI (US)

D611,879 S 3/2010 Kim et al.  
D612,297 S 3/2010 Peters et al.  
D613,645 S 4/2010 Song et al.  
D615,458 S 5/2010 Thompson et al.  
D623,090 S 9/2010 Cox et al.  
D627,262 S 11/2010 Ikeda et al.  
D635,488 S 4/2011 Phipps  
D644,147 S 8/2011 Suh et al.  
D644,567 S 9/2011 Kozub

(Continued)

(73) Assignee: **GM Global Technology Operations LLC**, Detroit, MI (US)

(\*\*) Term: **14 Years**

(21) Appl. No.: **29/471,417**

(22) Filed: **Oct. 31, 2013**

(51) **LOC (10) Cl.** ..... **12-08**

(52) **U.S. Cl.**  
USPC ..... **D12/92**

(58) **Field of Classification Search**  
CPC ..... B62D 35/00  
USPC ..... D12/86, 90-92; D21/421, 433, 434;  
296/181.1, 181.5

See application file for complete search history.

(56) **References Cited**

**U.S. PATENT DOCUMENTS**

D592,105 S 5/2009 Dean et al.  
D597,447 S 8/2009 Folden  
D603,755 S 11/2009 Peters  
D605,082 S 12/2009 Munson  
D605,083 S 12/2009 Manoogian, II et al.  
D605,978 S 12/2009 Wolff et al.  
D608,249 S 1/2010 Peters  
D608,690 S 1/2010 Folden et al.  
D608,691 S 1/2010 Zak, Jr. et al.  
D609,608 S 2/2010 Boniface et al.  
D611,387 S 3/2010 Thompson et al.

**OTHER PUBLICATIONS**

Design U.S. Appl. No. 29/407,580, filed Nov. 30, 2011; First Named Inventor: Robert J. Munson; Title: Vehicle Body.

(Continued)

*Primary Examiner* — Melody N Brown

(74) *Attorney, Agent, or Firm* — Lionel D. Anderson; Reising Ethington P.C.

(57) **CLAIM**

The ornamental design for a vehicle body exterior, as shown and described.

**DESCRIPTION**

FIG. 1 is a front elevation view of the vehicle body exterior; FIG. 2 is a front and left side perspective view thereof; FIG. 3 is a left side elevation view thereof; FIG. 4 is a top plan view thereof; FIG. 5 is a rear and left side perspective view thereof; and, FIG. 6 is a rear elevation view thereof.

In the drawings, the portions shown by broken lines form no part of the claim, and the right side elevation view of the vehicle body exterior is omitted because the right side elevation view is identical to the left side elevation view except that the right side elevation view has a gas cap cover as shown by broken lines in the top plan view.

**1 Claim, 6 Drawing Sheets**

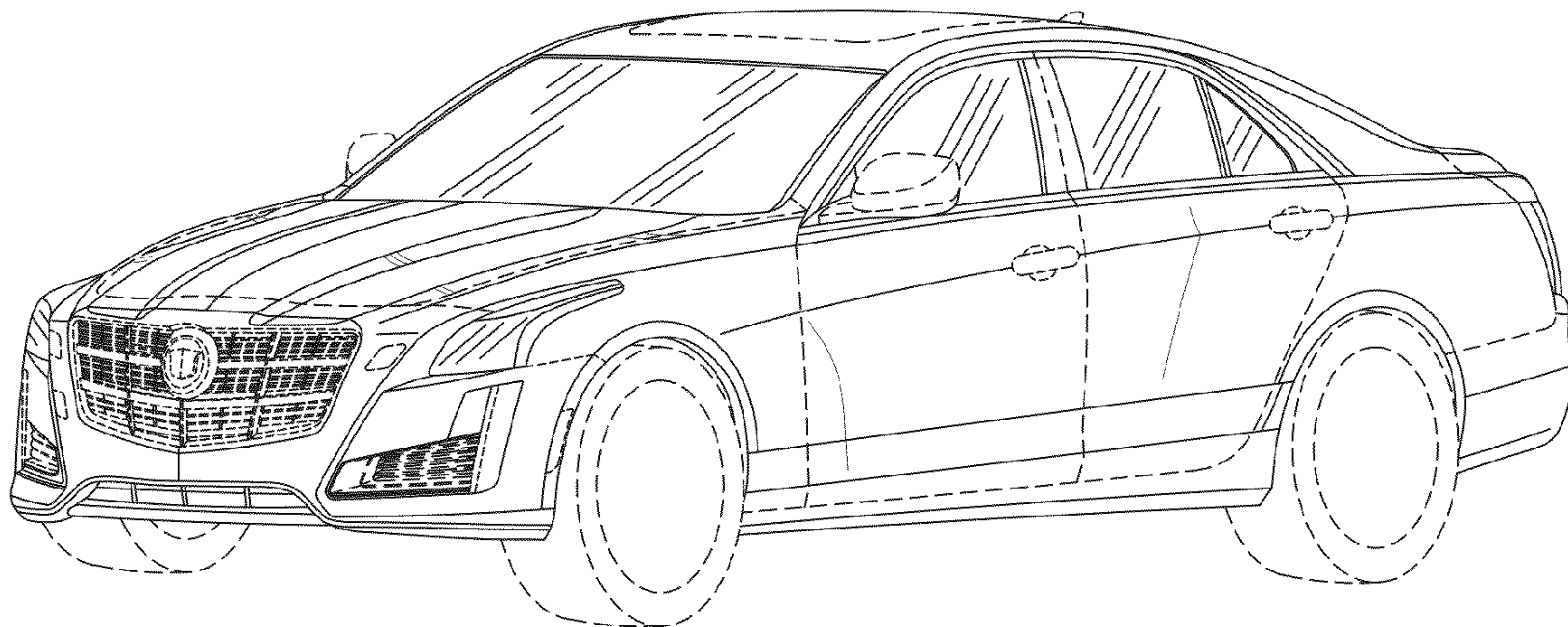

(56)

**References Cited**

U.S. PATENT DOCUMENTS

D668,182 S 10/2012 Barba Franco  
D668,183 S 10/2012 Smart  
D674,727 S \* 1/2013 Karras et al. .... D12/92  
D680,909 S \* 4/2013 Munson et al. .... D12/92  
D686,536 S 7/2013 McCabe et al.  
D704,103 S \* 5/2014 Mack et al. .... D12/92

OTHER PUBLICATIONS

Design U.S. Appl. No. 29/409,092, filed Dec. 20, 2011; First Named Inventor: Nicholas J. David; Title: Vehicle Body.  
Design U.S. Appl. No. 29/413,221, filed Feb. 13, 2012; First Named Inventor: Joseph C. Baker; Title: Vehicle Body.  
Design U.S. Appl. No. 29/414,260, filed Feb. 27, 2012; First Named Inventor: Steven M. McCabe; Title: Vehicle Body.

Design U.S. Appl. No. 29/416,870, filed Mar. 28, 2012; First Named Inventor: Joshua L. Thurber; Title: Vehicle Body.  
Design U.S. Appl. No. 29/417,143, filed Mar. 30, 2012; First Named Inventor: Andrew D. Smith; Title: Vehicle Body.  
Design U.S. Appl. No. 29/435,107, filed Oct. 19, 2012; First Named Inventor: John H. Ware; Title: Vehicle Body Exterior.  
Design U.S. Appl. No. 29/435,113, filed Oct. 19, 2012; First Named Inventor: John H. Ware; Title: Vehicle Body Exterior.  
Design U.S. Appl. No. 29/437,463, filed Nov. 16, 2012; First Named Inventor: Niels Loeb; Title: Motor Car.  
Design U.S. Appl. No. 29/440,876, filed Dec. 28, 2012; First Named Inventor: John P. Mack; Title: Vehicle Body Exterior.  
Design U.S. Appl. No. 29/450,700, filed Mar. 21, 2013; First Named Inventor: Andrew Dyson; Title: Motor Car.  
Design U.S. Appl. No. 29/451,178, filed Mar. 28, 2013; First Named Inventor: Richard Fulvio Ferlazzo; Title: Vehicle Body Exterior.  
Design U.S. Appl. No. 29/476,490, filed Dec. 13, 2013; First Named Inventor: Robert J. Munson; Title: Vehicle Body Exterior.

\* cited by examiner

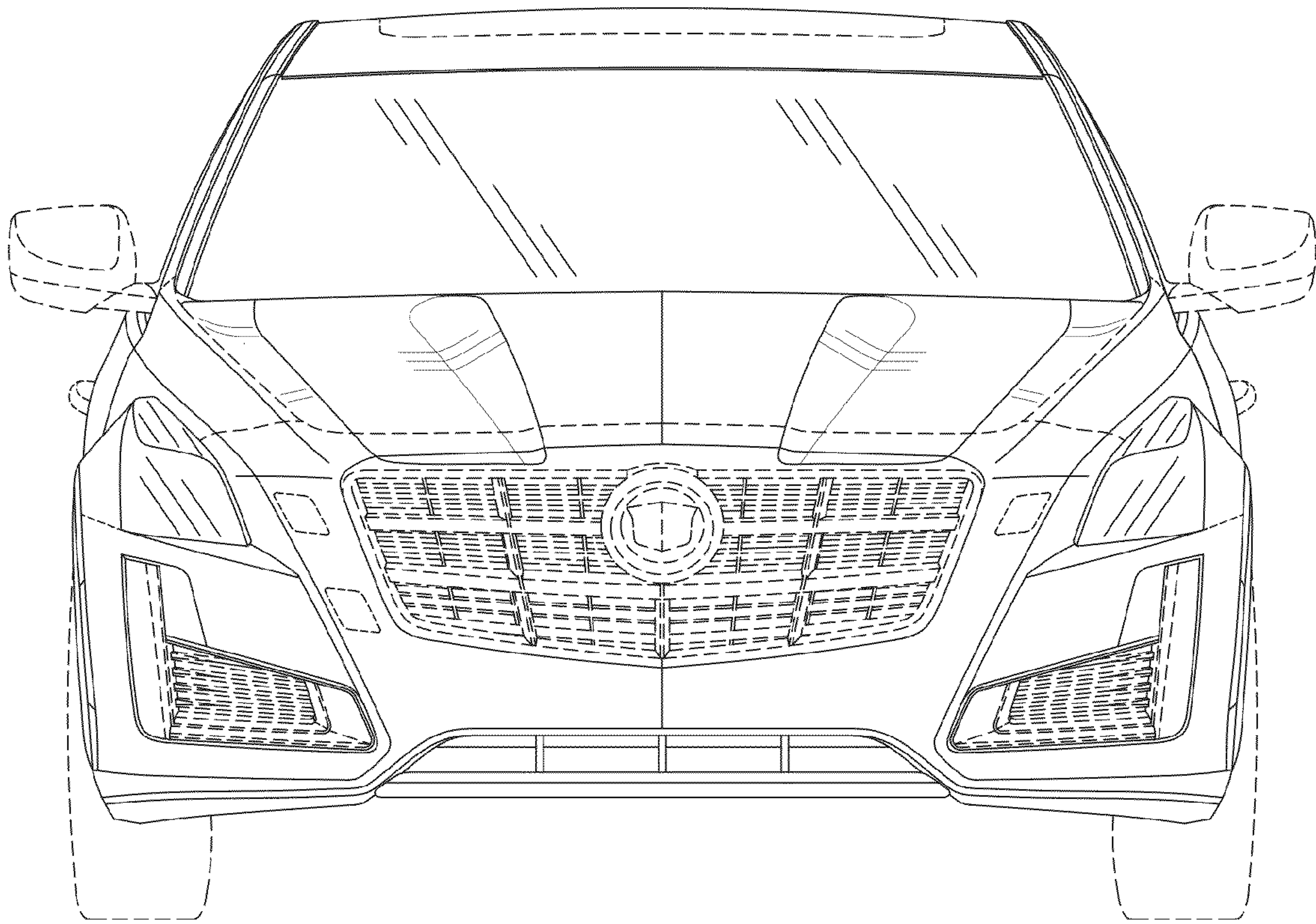

Fig-1



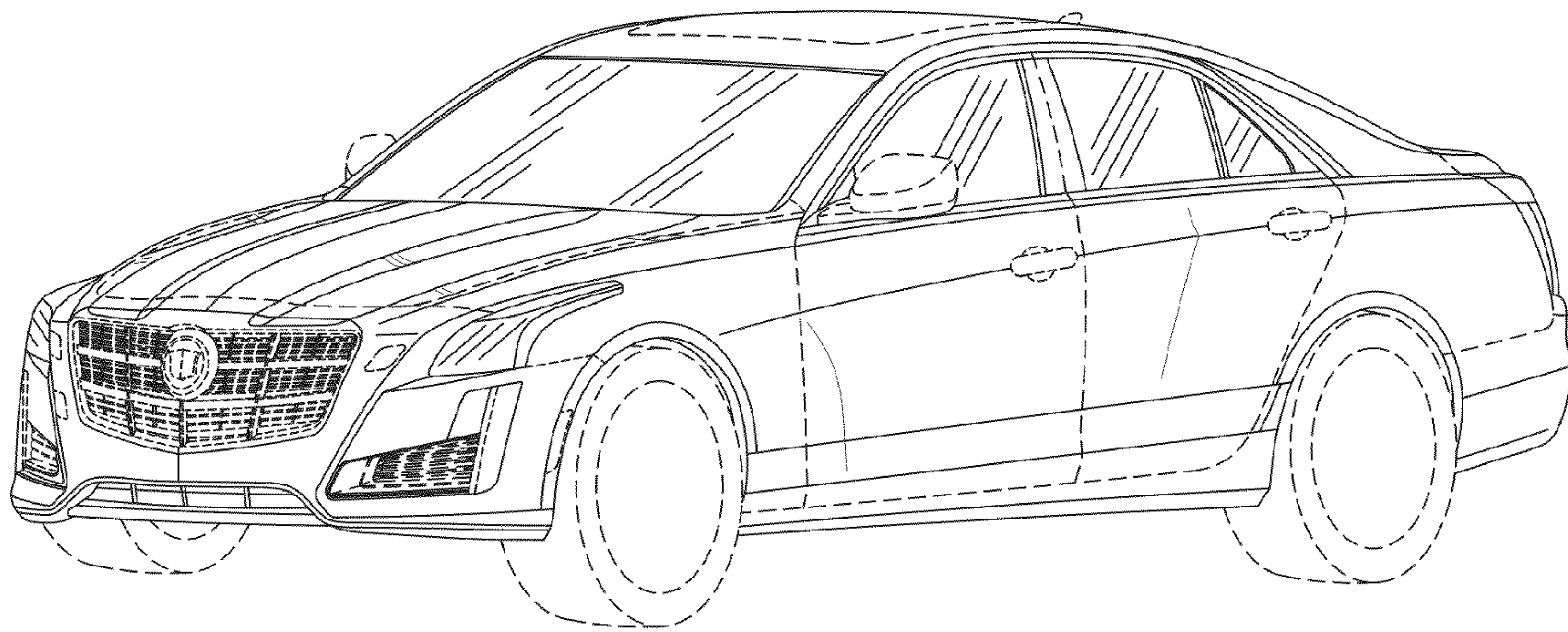

Fig-2

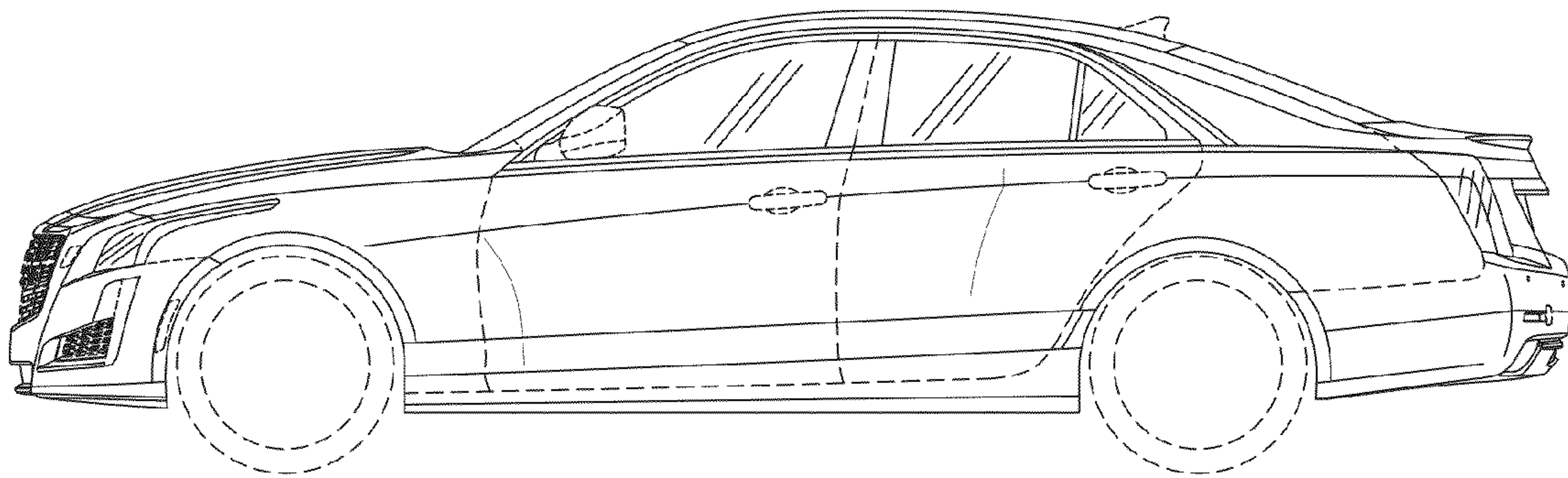

Fig-3

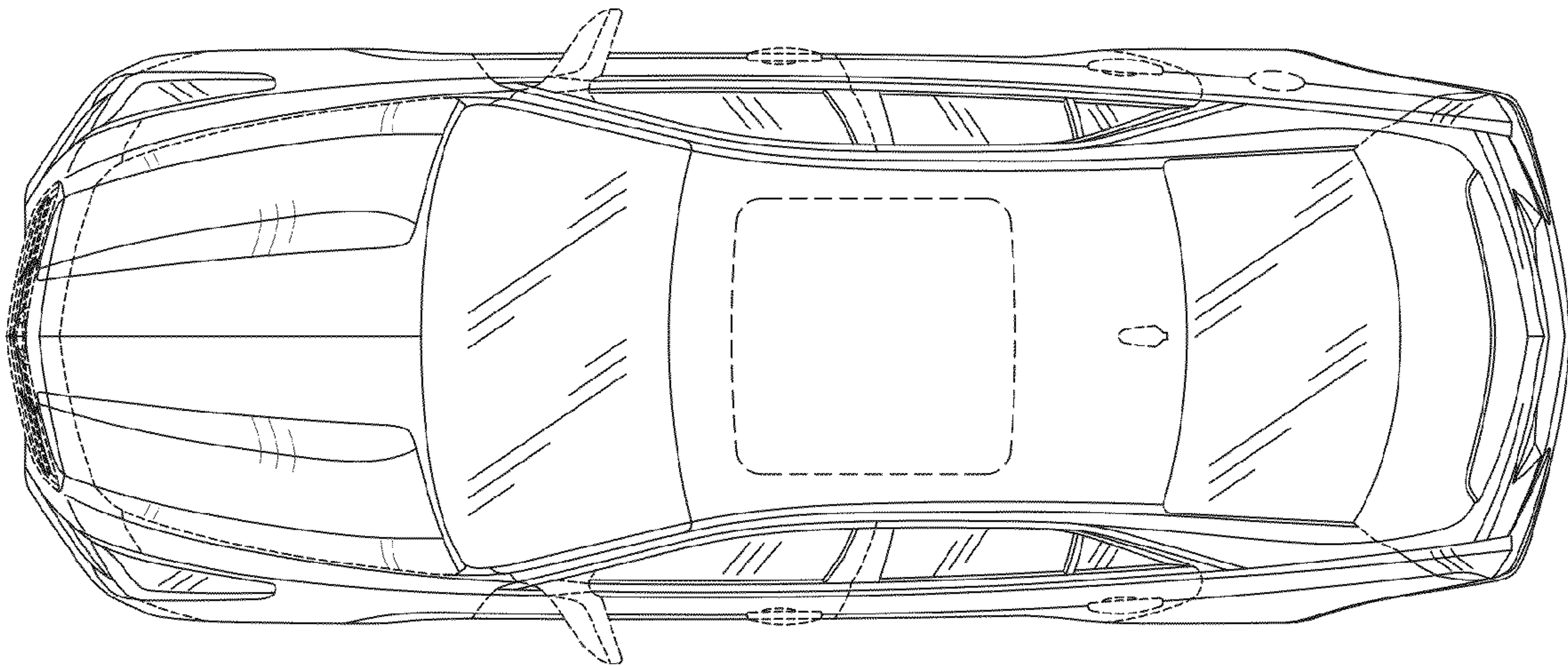

Fig-4

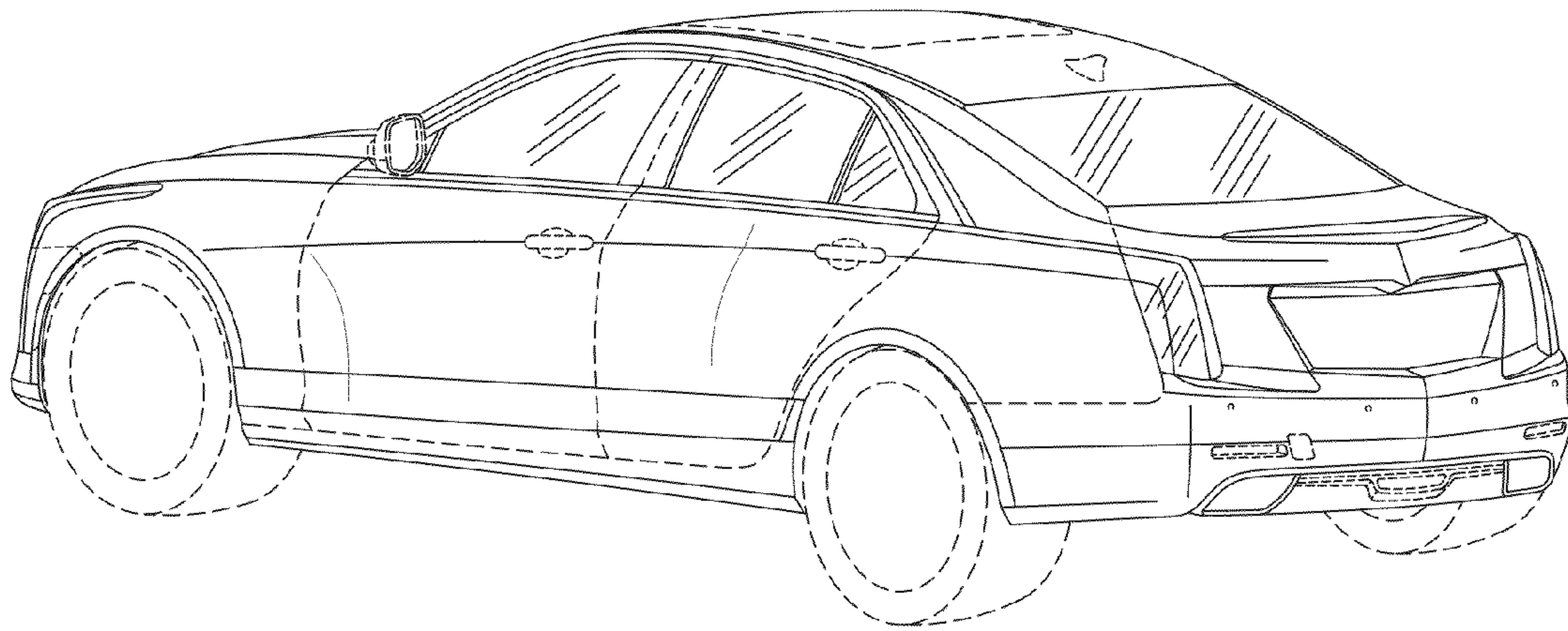

Fig-5

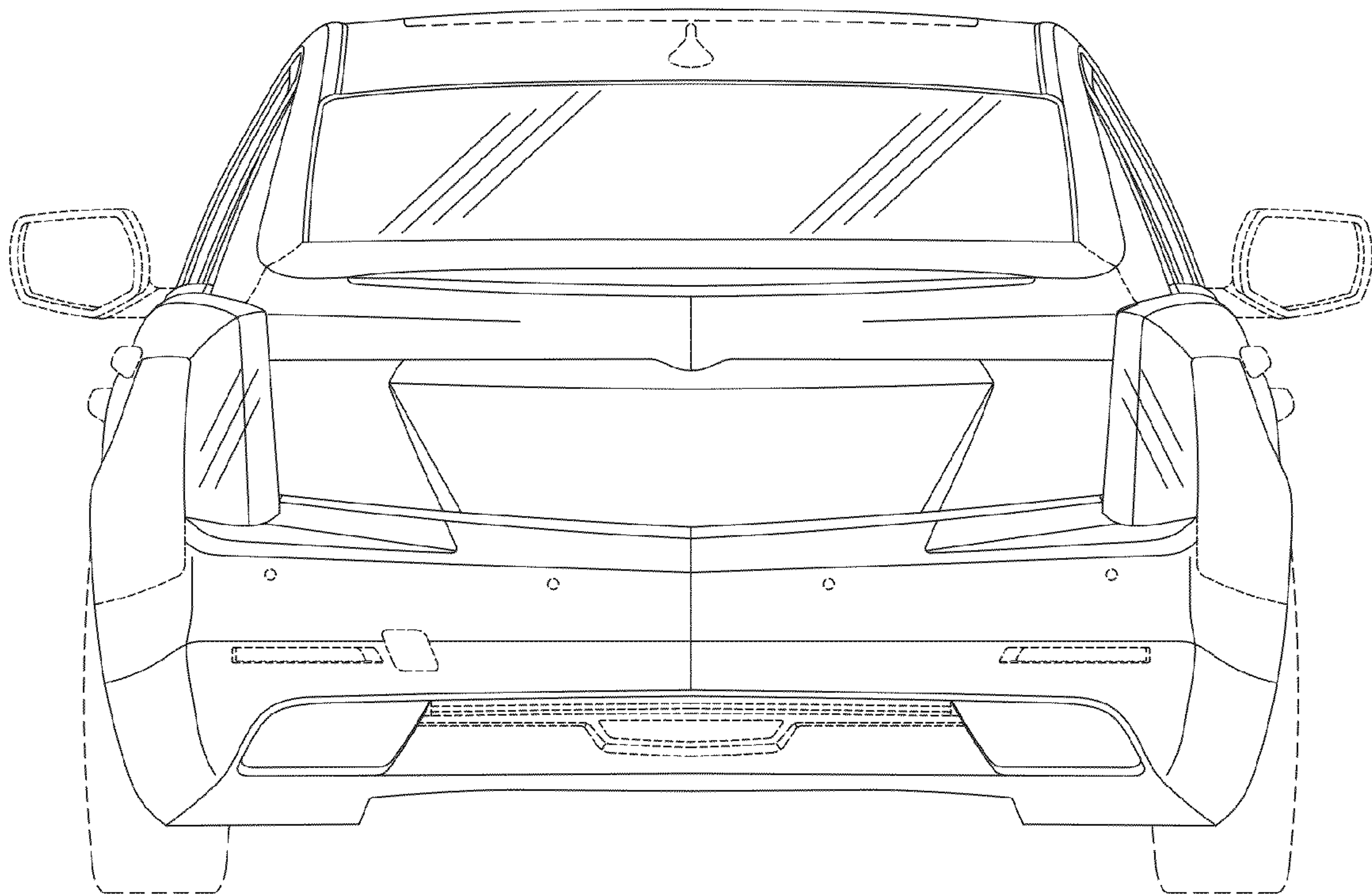

Fig-6