



US00D717496S

(12) **United States Design Patent**
Gautier

(10) **Patent No.:** **US D717,496 S**

(45) **Date of Patent:** **** Nov. 11, 2014**

(54) **LIPSTICK CASE**

(56) **References Cited**

(71) Applicant: **Parfums Christian Dior**, Paris (FR)

U.S. PATENT DOCUMENTS

(72) Inventor: **François Gautier**, Paris (FR)

1,919,887	A *	7/1933	Gleeson	401/180
7,165,558	B2 *	1/2007	Byun	132/294
D562,137	S *	2/2008	Florio	D9/502
D682,476	S *	5/2013	Chen et al.	D28/85
2004/0134819	A1 *	7/2004	Blackwell	206/385

(73) Assignee: **Parfums Christian Dior, S.A.**, Paris (FR)

* cited by examiner

(**) Term: **14 Years**

Primary Examiner — Jennifer Rivard

(21) Appl. No.: **29/468,773**

(74) *Attorney, Agent, or Firm* — Fross Zelnick Lehrman & Zissu, P.C.; Charles T. J. Weigell, Esq.

(22) Filed: **Oct. 3, 2013**

(57) **CLAIM**

The ornamental design for a lipstick case, as shown and described.

(30) **Foreign Application Priority Data**

DESCRIPTION

Apr. 4, 2013 (EM) 002213819

(51) **LOC (10) Cl.** **28-03**

FIG. 1 is a front view of a lipstick case showing the new design, the rear view being a mirror image thereof.

(52) **U.S. Cl.**

FIG. 2 is a right side view thereof.

USPC **D28/85**; D28/77

FIG. 3 is a left side view thereof.

(58) **Field of Classification Search**

FIG. 4 is a top view thereof.

CPC A45D 34/06; A45D 34/05; A45D 34/042-34/048; A45D 40/426; A45D 40/267; A45D 2004/0012; A45D 2200/1009; A45D 2200/1018; A45D 2200/1036

FIG. 5 is front, top and left side perspective view thereof; and, FIG. 6 is a one point front perspective view thereof, with the two parts of the lipstick case separated from one another.

USPC D28/76, 85-90, 77; 132/317, 320, 318; 206/581, 823, 385; 401/68, 88, 98

In the drawings, the broken lines in figure are included for the purpose of illustrating interior structures that form no part of the claimed design.

See application file for complete search history.

1 Claim, 5 Drawing Sheets

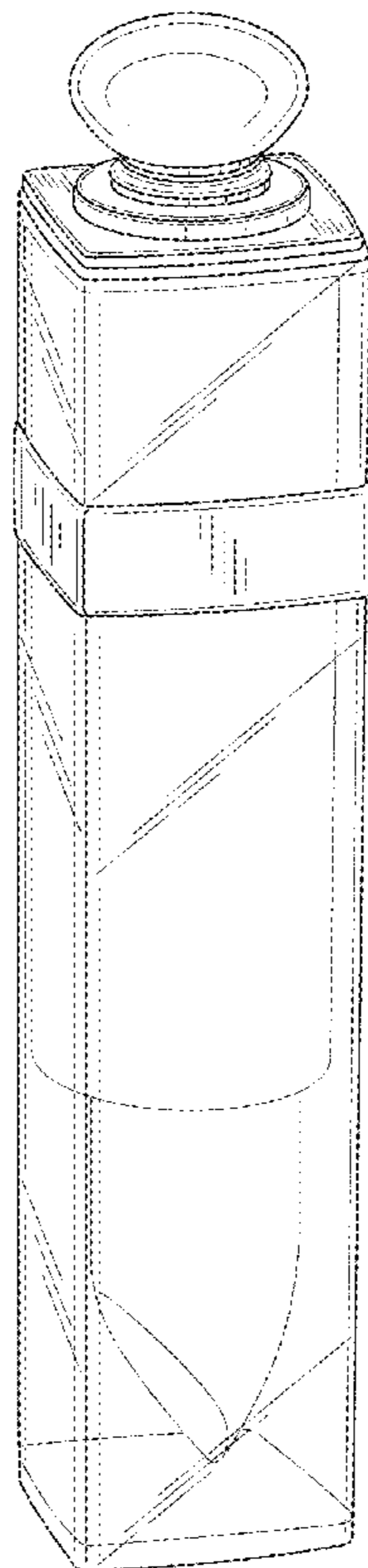

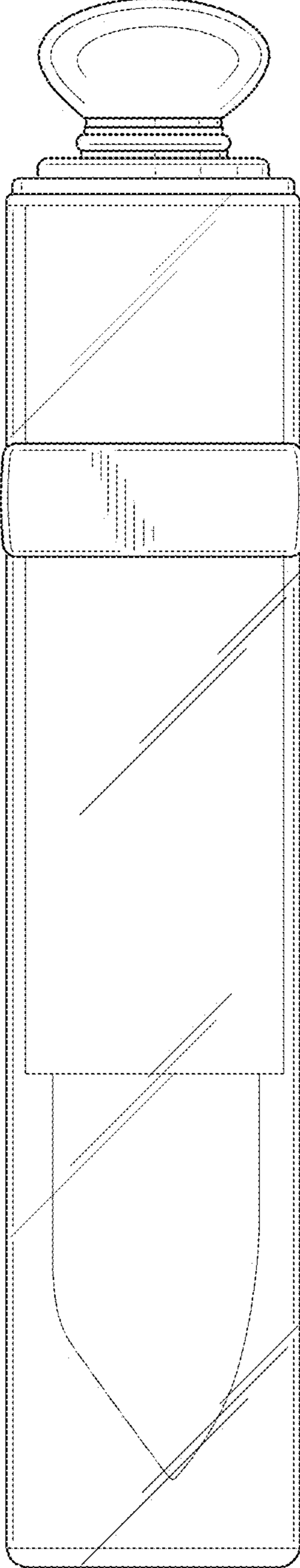

FIG. 1

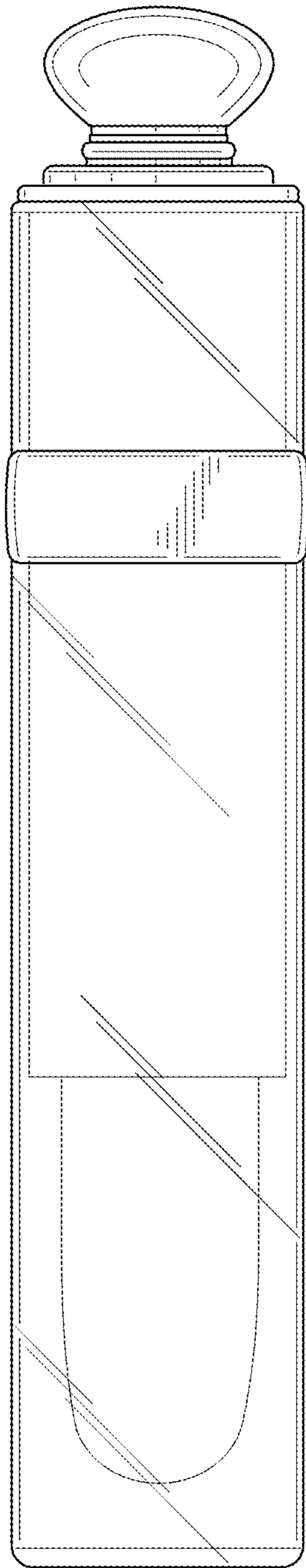

FIG. 2

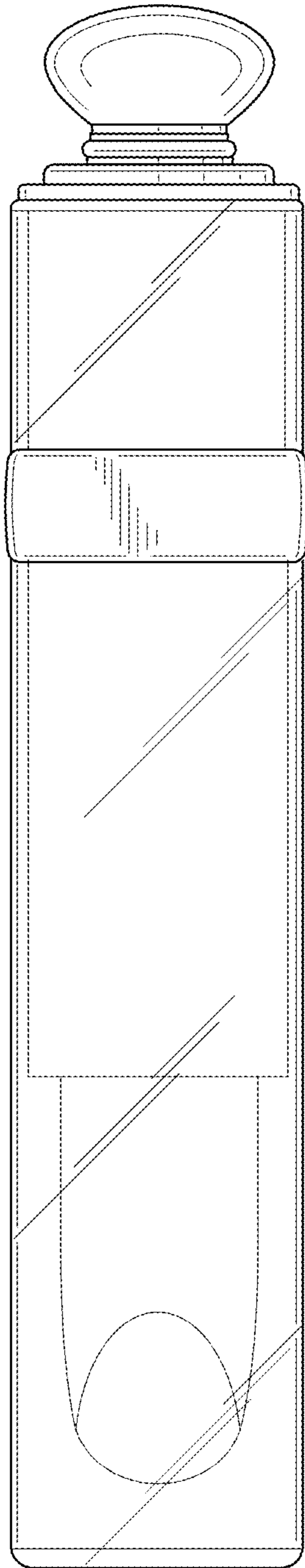

FIG. 3

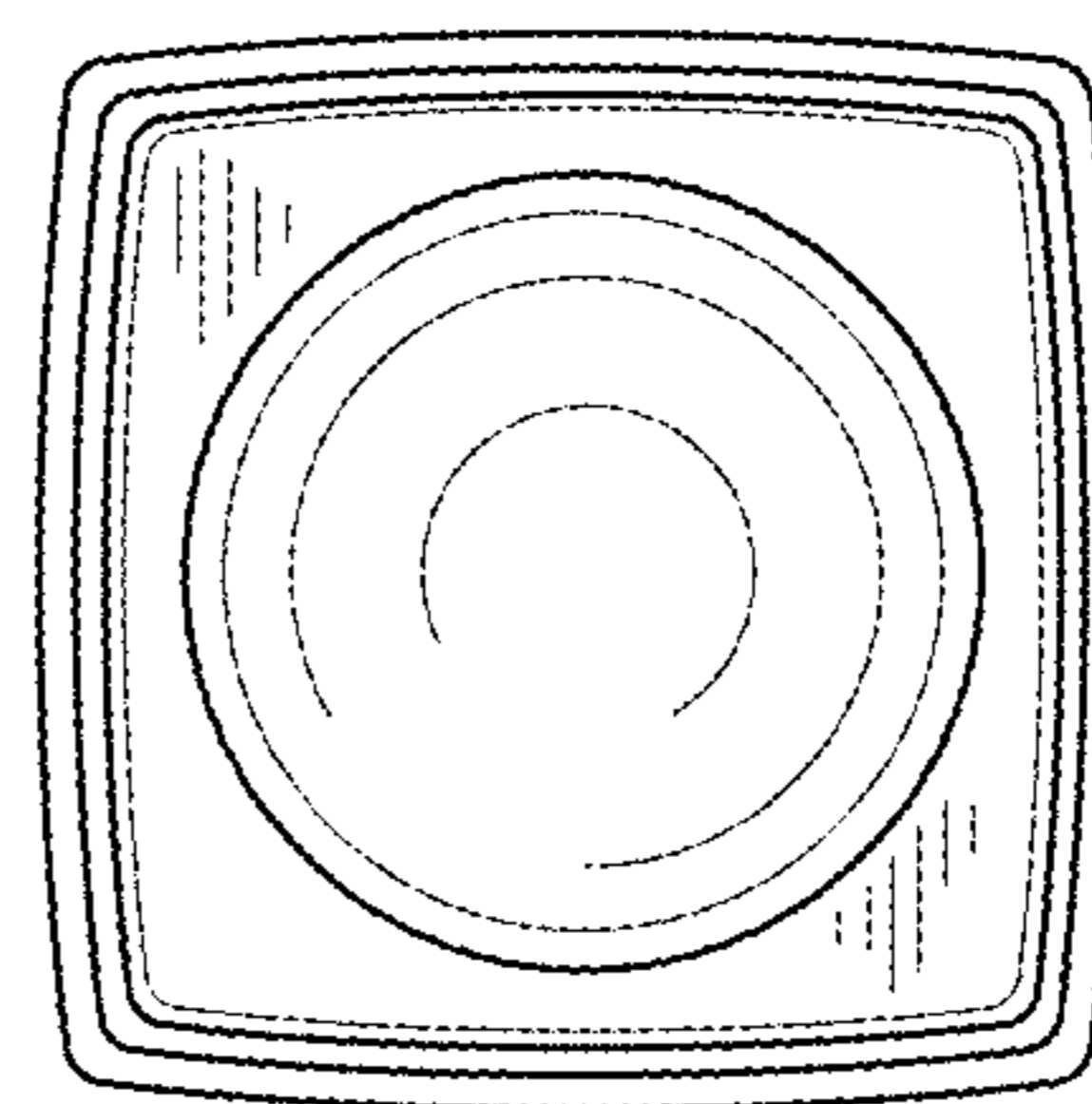

FIG. 4

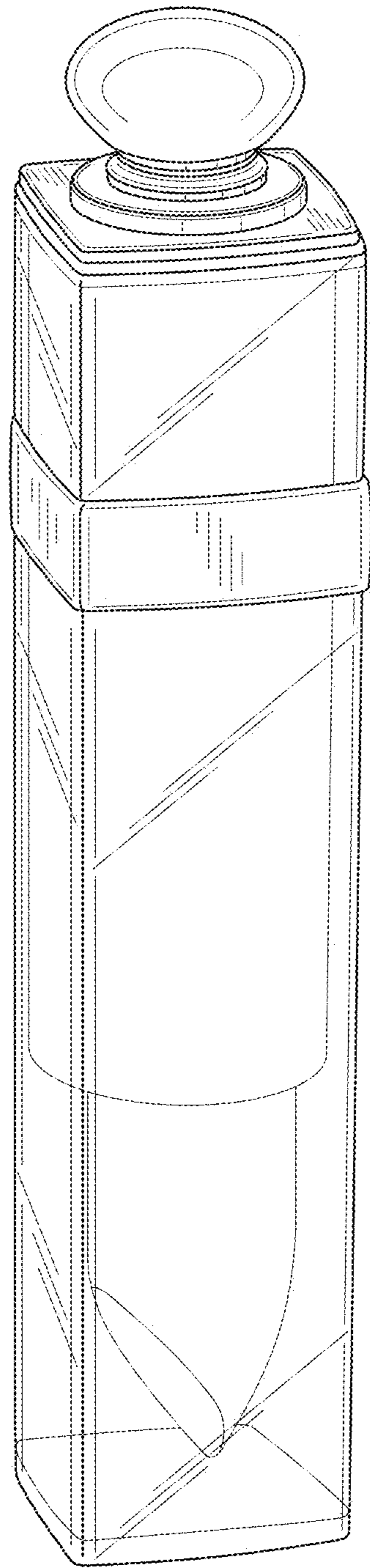

FIG. 5

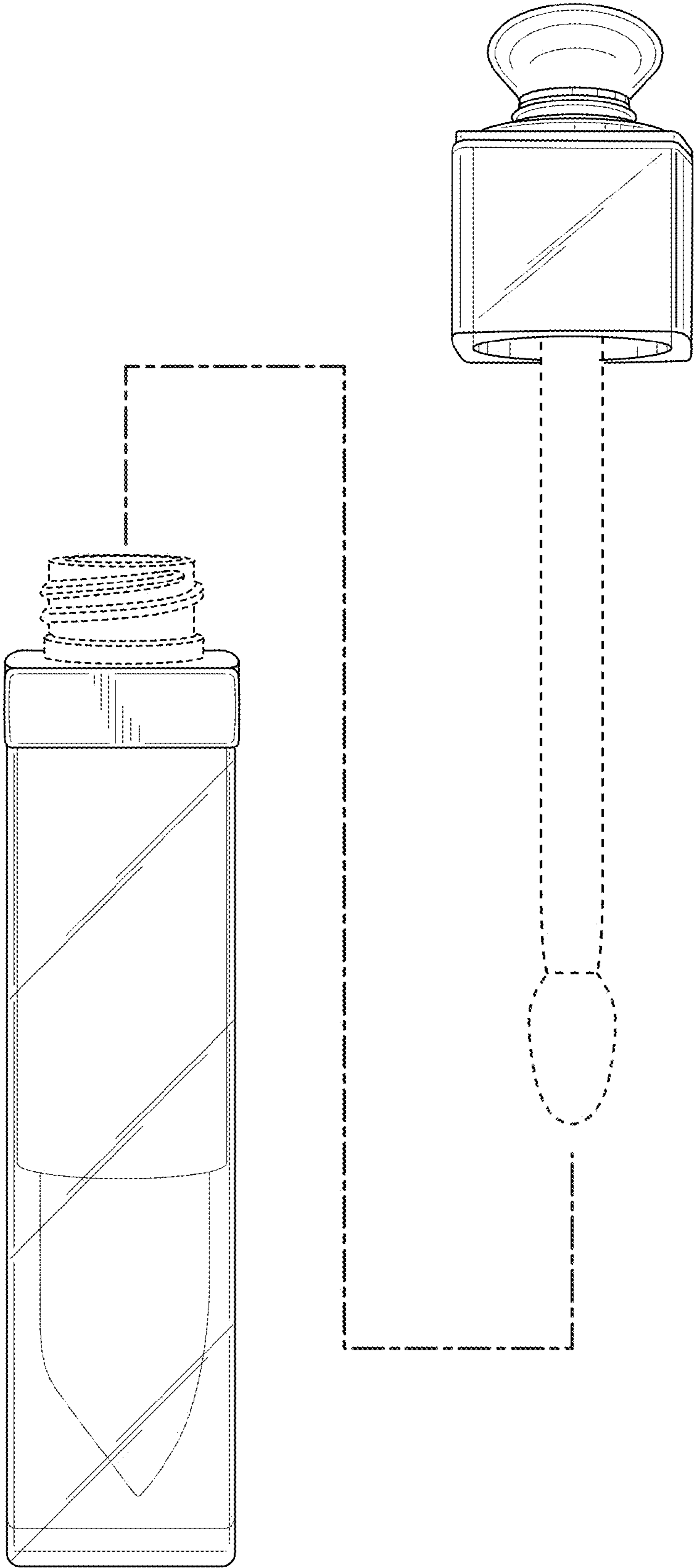

FIG. 6