



US00D717366S

(12) **United States Design Patent**
Korfker

(10) **Patent No.:** **US D717,366 S**

(45) **Date of Patent:** **** Nov. 11, 2014**

(54) **SHOULDER REST FOR STRINGED INSTRUMENT**

(75) Inventor: **Berent Korfker**, Amsterdam (NL)

(73) Assignee: **Gustav Pirazzi & Comp. KG**,
Offenbach am Main (DE)

(**) Term: **14 Years**

(21) Appl. No.: **29/405,214**

(22) Filed: **Oct. 31, 2011**

(30) **Foreign Application Priority Data**

Apr. 29, 2011 (DE) 40 2011 001 590

(51) **LOC (10) Cl.** **17-03**

(52) **U.S. Cl.**
USPC **D17/20**

(58) **Field of Classification Search**
USPC D17/20, 99; 84/278-280, 327, 328,
84/387 A, 403
See application file for complete search history.

(56) **References Cited**

U.S. PATENT DOCUMENTS

2,223,221	A	11/1940	Miranda	
3,298,269	A	1/1967	White	
3,479,916	A	11/1969	Wolf	
3,631,754	A *	1/1972	Kun	84/280
4,062,695	A	12/1977	Pieck	
4,185,534	A	1/1980	Cove	
4,333,378	A *	6/1982	Hrdlicka	84/280
4,719,835	A	1/1988	Biasini et al.	
D334,019	S *	3/1993	Kun	D17/20
5,275,078	A	1/1994	Wolf	
5,341,714	A	8/1994	Roulet	
D352,053	S *	11/1994	Murray	D17/20
D385,292	S *	10/1997	Kun	D17/20
D406,269	S *	3/1999	Mach	D17/20
6,031,163	A *	2/2000	Cullum et al.	84/279
6,278,044	B1 *	8/2001	Ruan	84/279
6,291,750	B1	9/2001	Farha	
6,670,533	B1	12/2003	Yeh	
6,891,093	B2 *	5/2005	Huang	84/278

7,262,352	B1	8/2007	Lavorata	
7,265,284	B2	9/2007	Muir et al.	
D561,236	S *	2/2008	Muir et al.	D17/20
7,368,645	B2	5/2008	Armstrong et al.	
7,385,124	B2	6/2008	Clemente	
7,476,789	B1	1/2009	Federici	
7,488,877	B2	2/2009	Cheng et al.	
D636,014	S *	4/2011	Cheng	D17/20
D688,732	S *	8/2013	Johnson	D17/20
8,618,392	B2	12/2013	Korfker	
2006/0174743	A1	8/2006	Clemente	
2012/0006176	A1 *	1/2012	Ruan	84/280
2012/0137853	A1	6/2012	Korfker	
2013/0125728	A1	5/2013	Korfker	

FOREIGN PATENT DOCUMENTS

CH	527 479	10/1972
DE	114 285	8/1899
DE	36 43 225	7/1987
DE	37 07 656	6/1988
DE	41 37 918	4/1992
EP	0 353 824	2/1990
EP	0 540 978	5/1993
GB	639350	6/1950
GB	2 052 828	1/1981
GB	2 444 972	6/2008
JP	60-042906 U	3/1985
JP	60-084597 A	5/1985
JP	02-053301 U	4/1990
JP	10-214081 A	8/1998
JP	2006-065263 A	3/2006

* cited by examiner

Primary Examiner — Rashida Johnson

(74) *Attorney, Agent, or Firm* — W. F. Fasse

(57) **CLAIM**

The ornamental design for a shoulder rest for stringed instrument, as shown and described.

DESCRIPTION

FIG. 1 is a top view of an instrument support cradle of a shoulder rest for stringed instrument showing my new design. FIG. 2 is a bottom view of the instrument support cradle of the shoulder rest for stringed instrument.

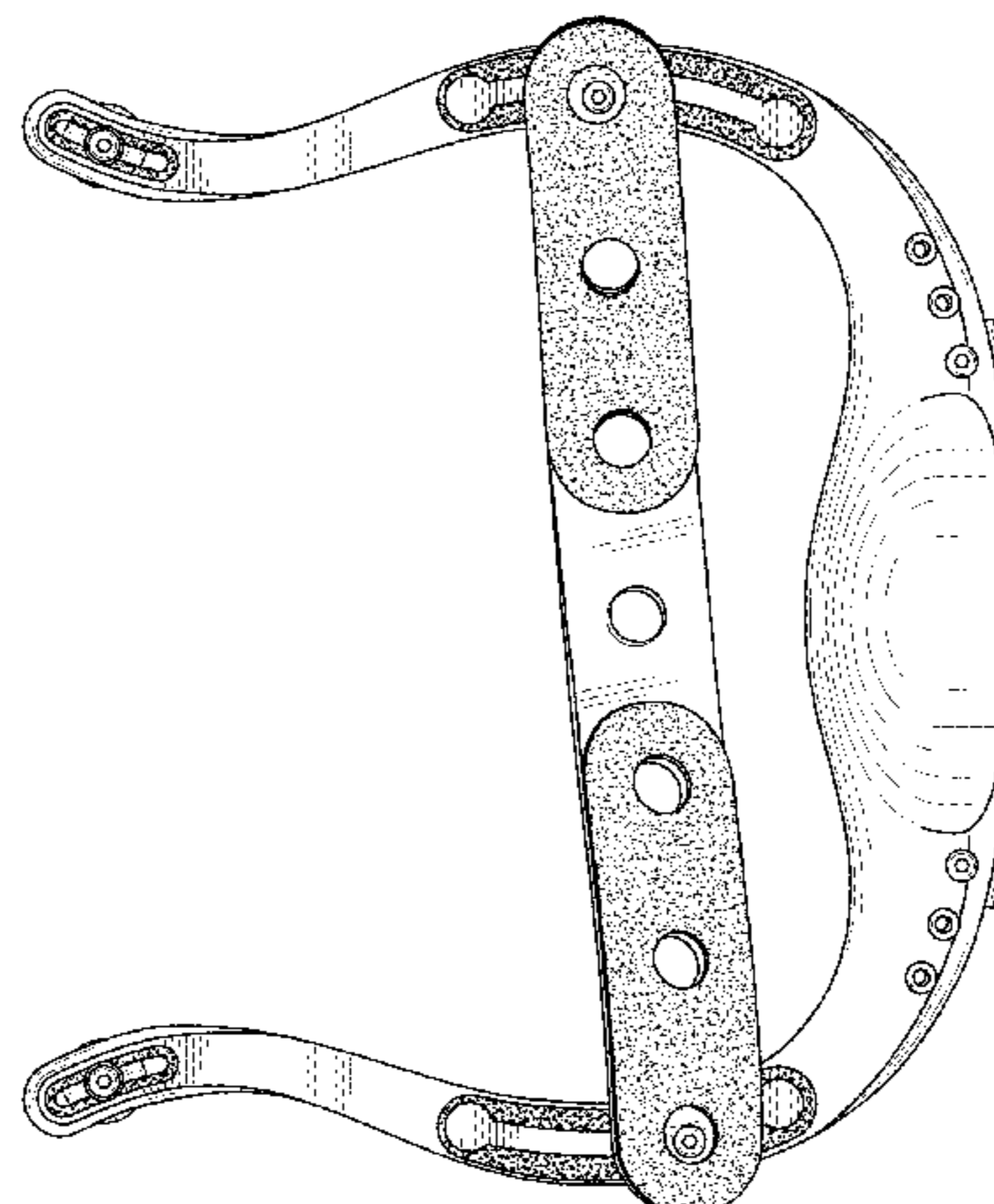
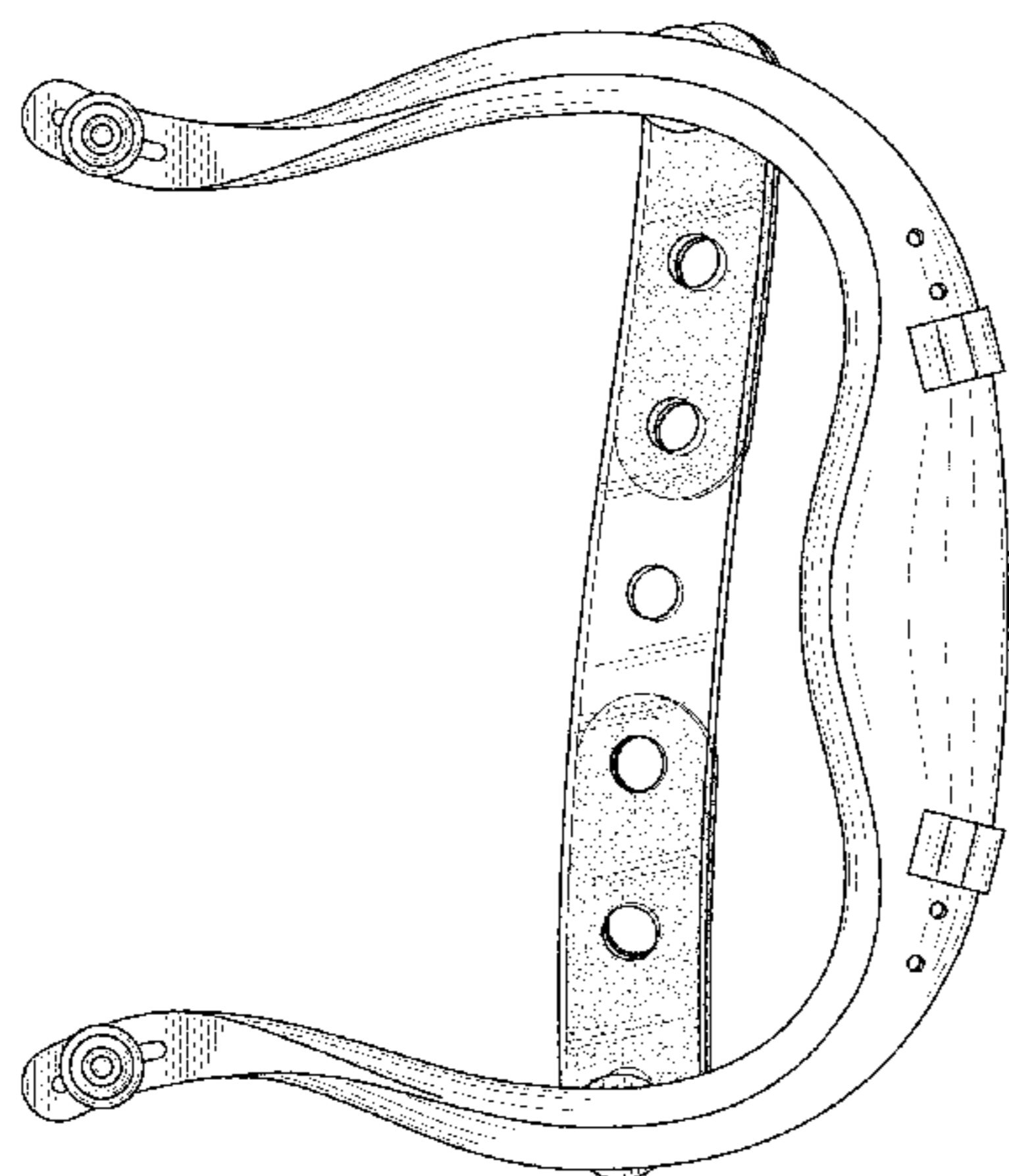

FIG. 3 is a bottom and right side perspective detail view, on an enlarged scale, of a right portion of the instrument support cradle of the shoulder rest for stringed instrument.

FIG. 4 is a top and right side perspective detail view, on a further enlarged scale, of a right portion of the instrument support cradle of the shoulder rest for stringed instrument.

FIG. 5 is a right side view of the right portion of the instrument support cradle of the shoulder rest for stringed instrument.

FIG. 6 is a top, front and right side perspective view of a shoulder rest component of the shoulder rest for stringed instrument.

FIG. 7 is a bottom and rear perspective view of the shoulder rest component of the shoulder rest for stringed instrument.

FIG. 8 is a bottom and rear perspective view, on an enlarged scale, of a left portion of the shoulder rest component of the shoulder rest for stringed instrument.

FIG. 9 is a top, front and right side perspective view, on an enlarged scale, of the left portion of the shoulder rest component of the shoulder rest for stringed instrument.

FIG. 10 is a top and front perspective view, on an enlarged scale, of a right portion of the shoulder rest component of the shoulder rest for stringed instrument.

FIG. 11 is a bottom and rear perspective view, on an enlarged scale, of the right portion of the shoulder rest component of the shoulder rest for stringed instrument.

FIG. 12 is a top view of the complete shoulder rest for stringed instrument, including the instrument support cradle and the shoulder rest component.

FIG. 13 is a bottom view of the complete shoulder rest for stringed instrument.

FIG. 14 is a top, front and right side perspective view of the complete shoulder rest for stringed instrument.

FIG. 15 is a front and right side perspective view of the complete shoulder rest for stringed instrument.

FIG. 16 is a bottom, front and right side perspective view of a right portion of the complete shoulder rest for stringed instrument.

FIG. 17 is a top and right side perspective view of a left portion of the complete shoulder rest for stringed instrument.

FIG. 18 is a top, front and right side perspective detail view, on an enlarged scale, of a right portion of the complete shoulder rest for stringed instrument.

FIG. 19 is a top, front and right side perspective view of a right portion of the complete shoulder rest for stringed instrument; and,

FIG. 20 is a top, front and right side perspective detail view, on an enlarged scale, of a portion of the instrument support cradle of the shoulder rest for stringed instrument.

1 Claim, 10 Drawing Sheets

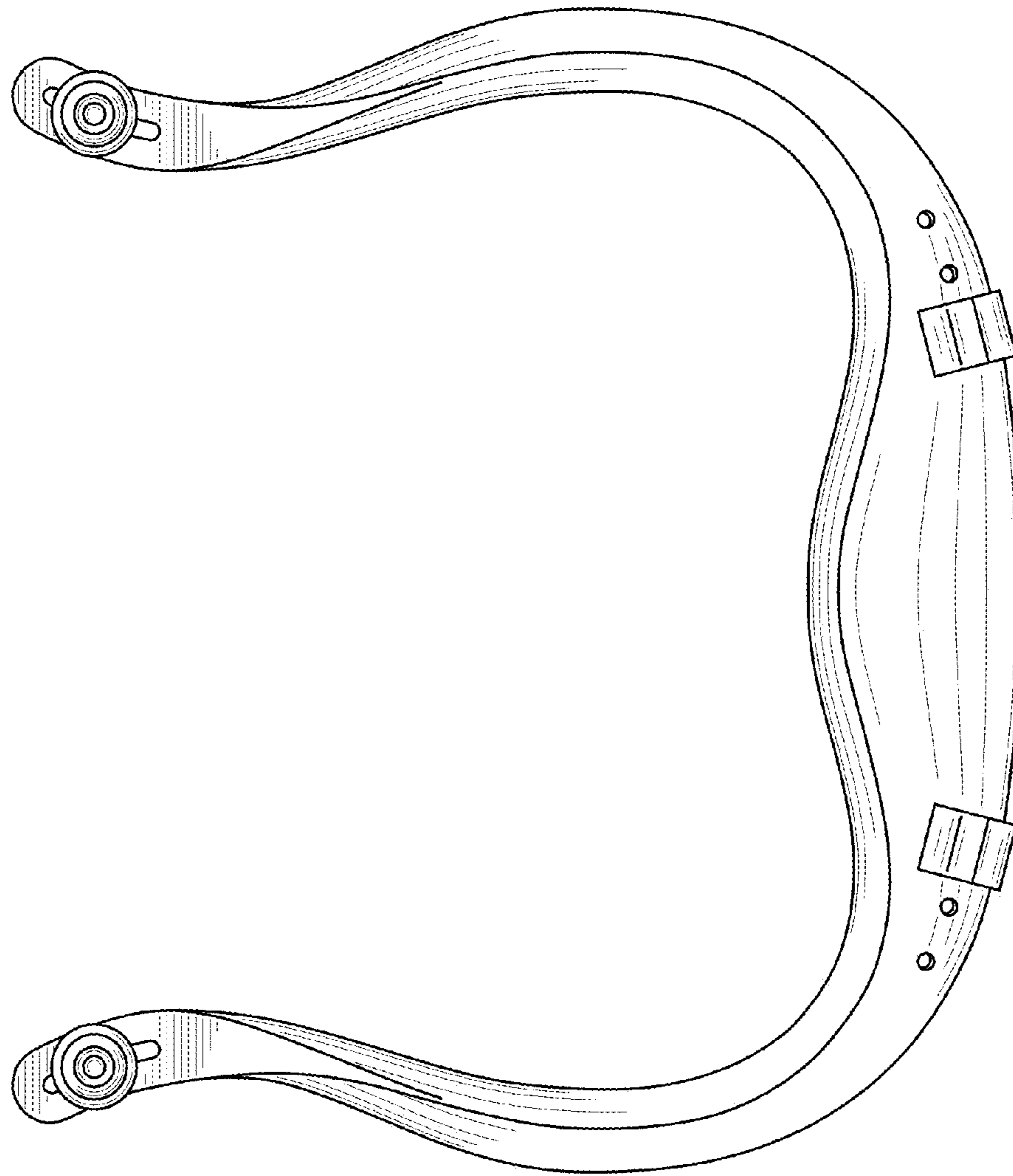

FIG. 1

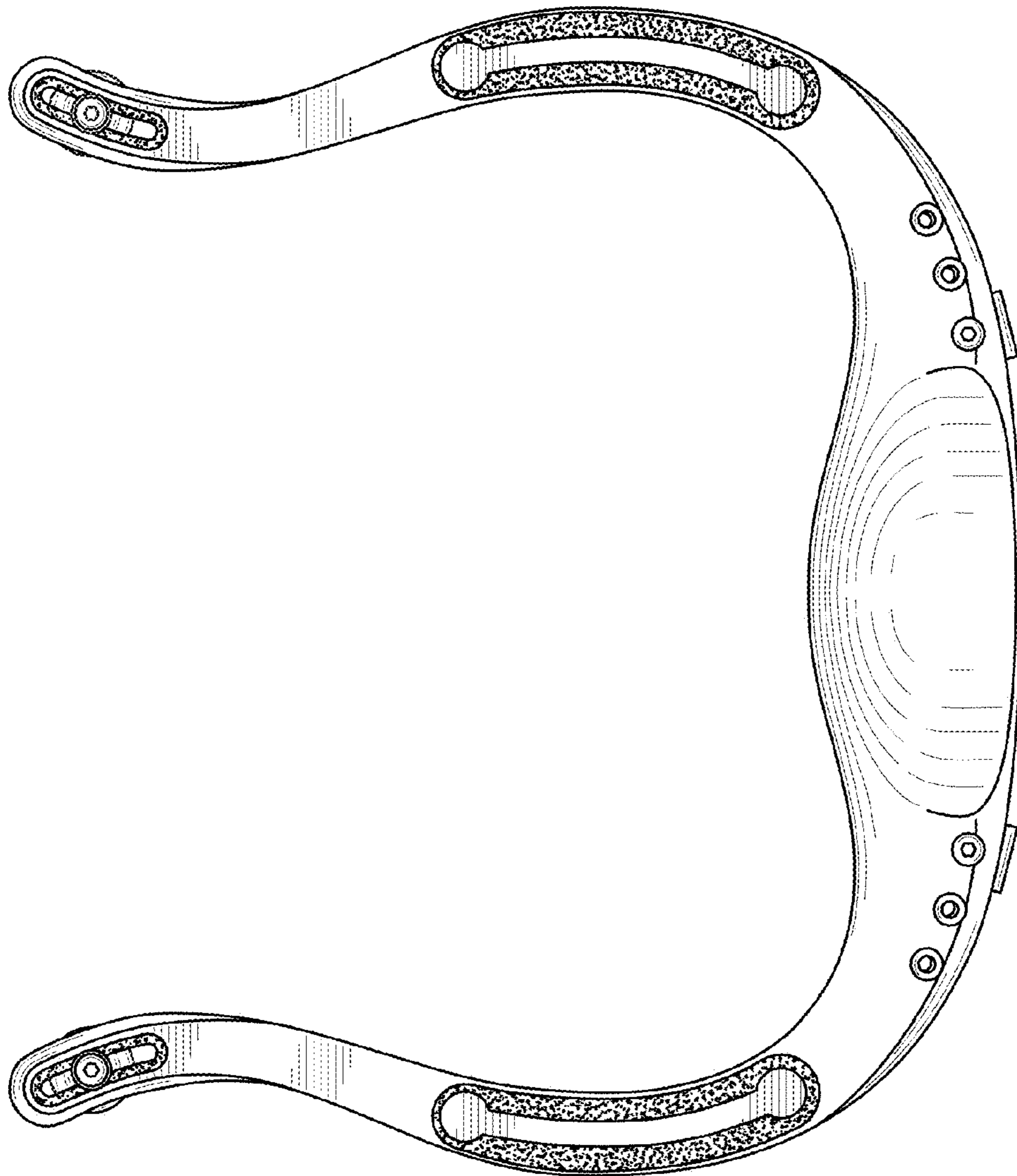

FIG. 2

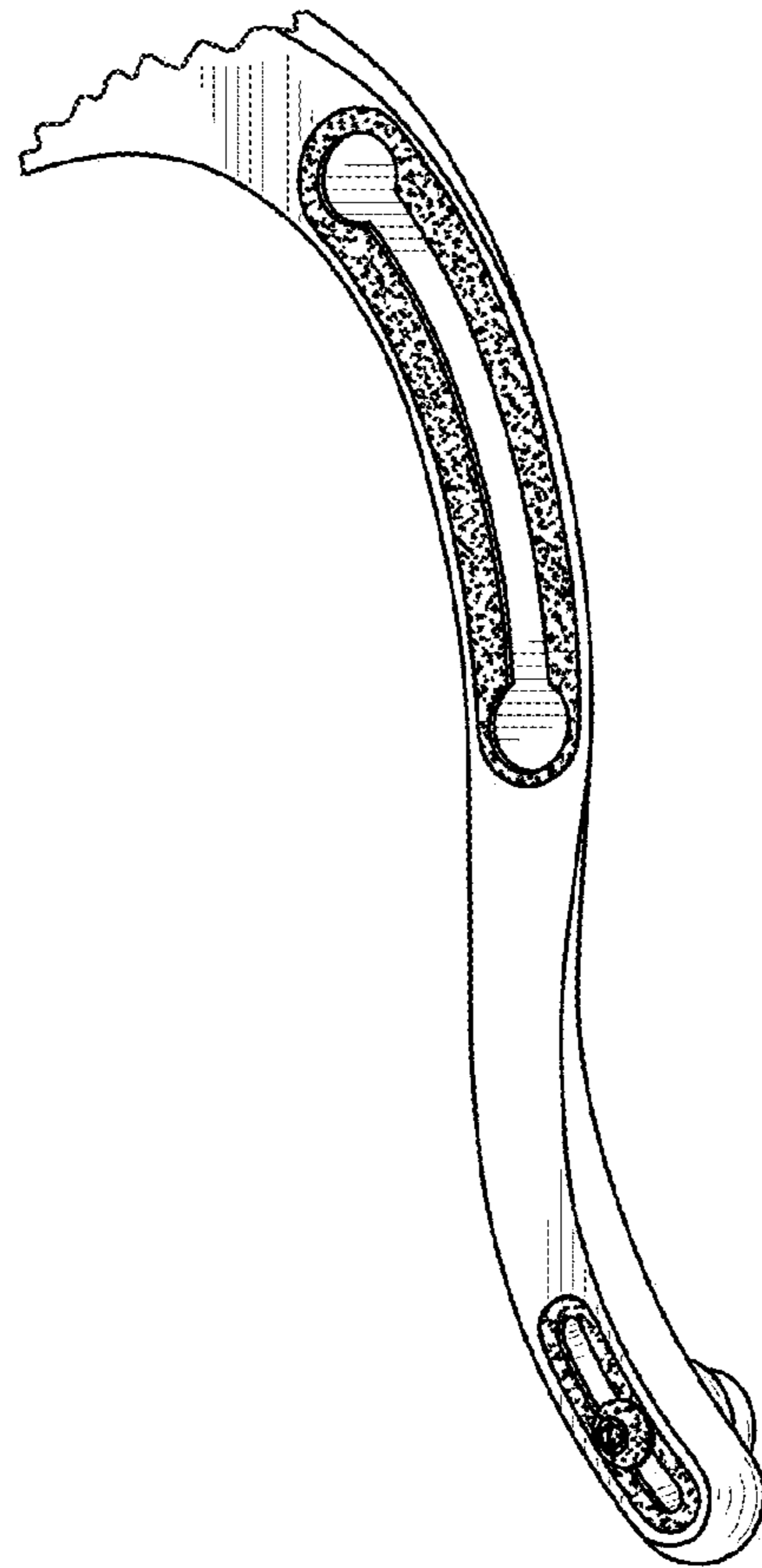

FIG. 3

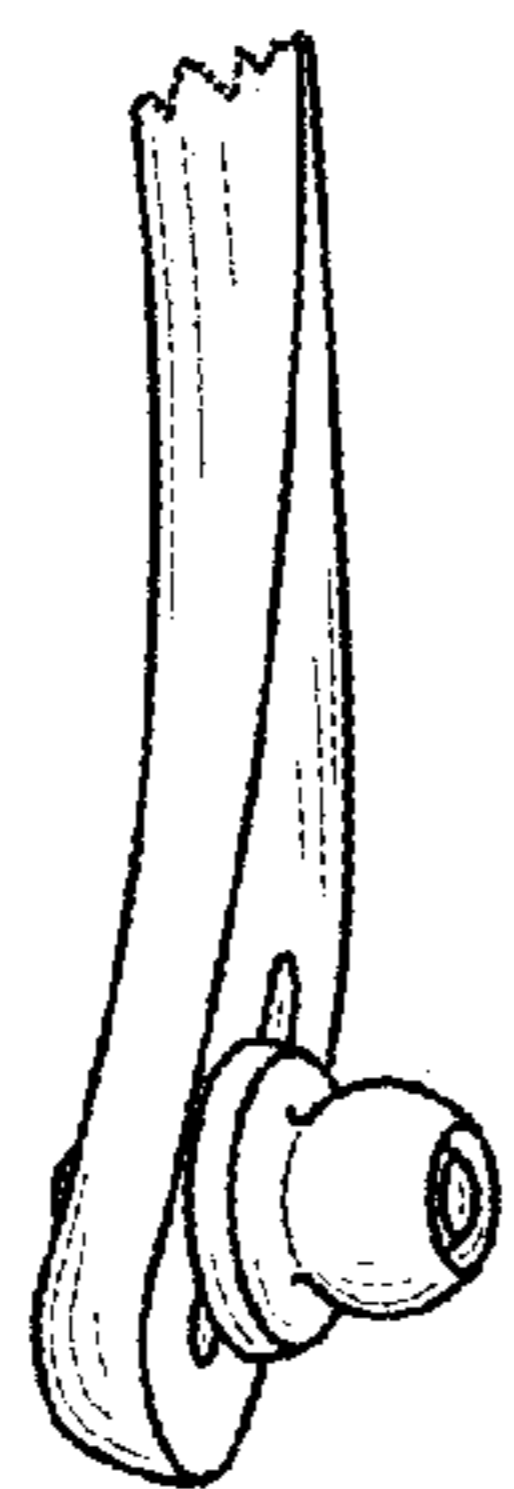

FIG. 4

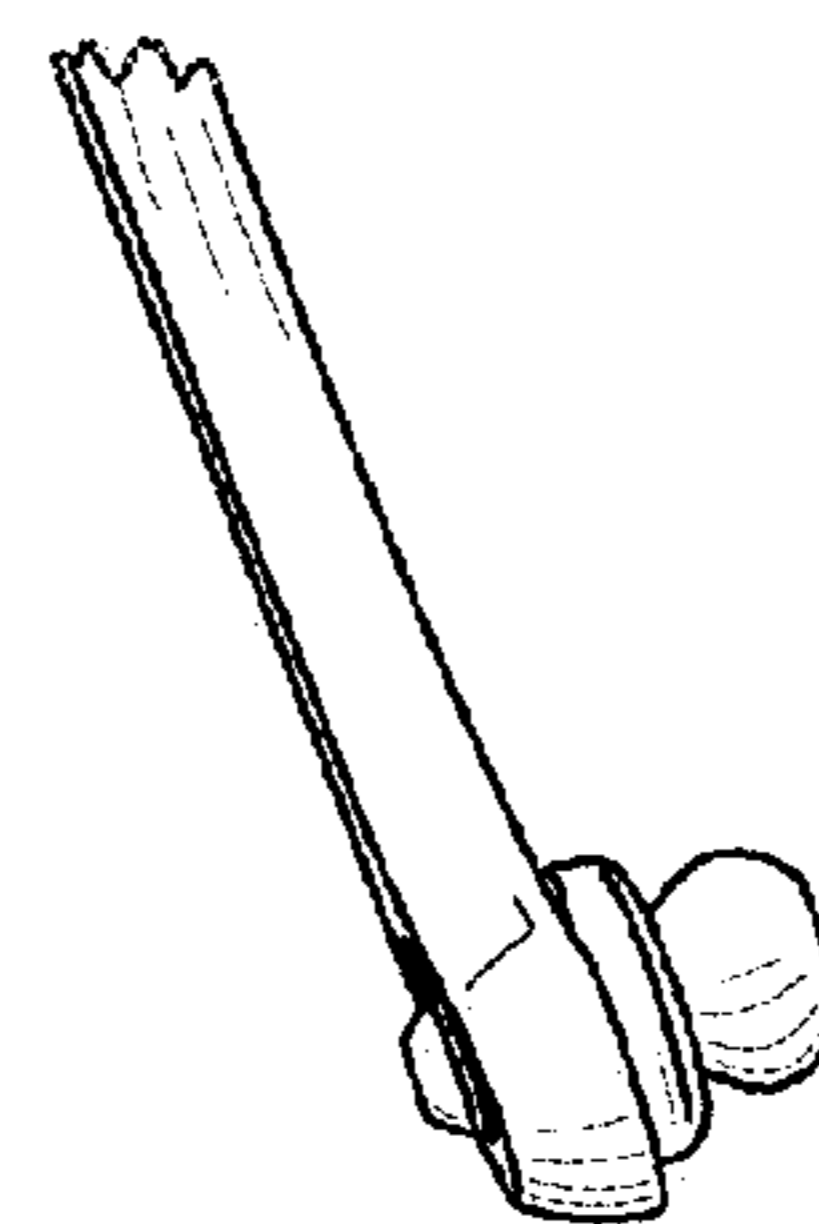

FIG. 5

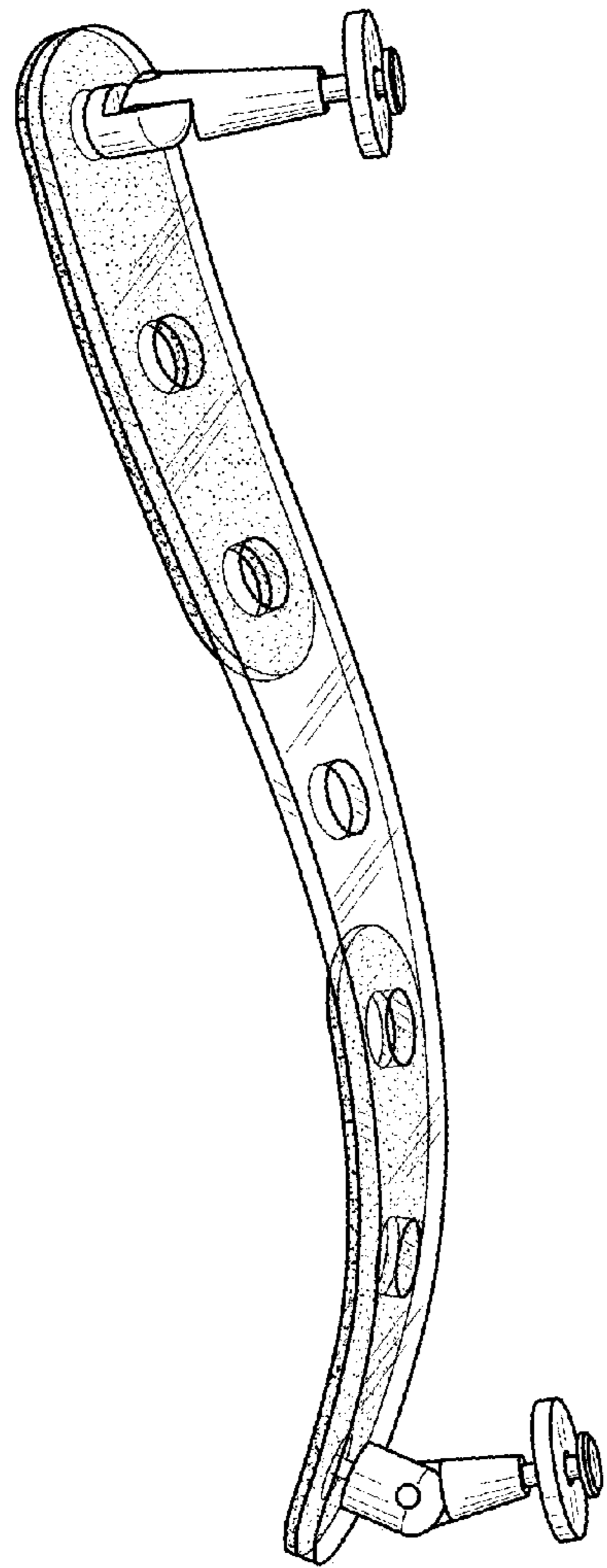

FIG. 6

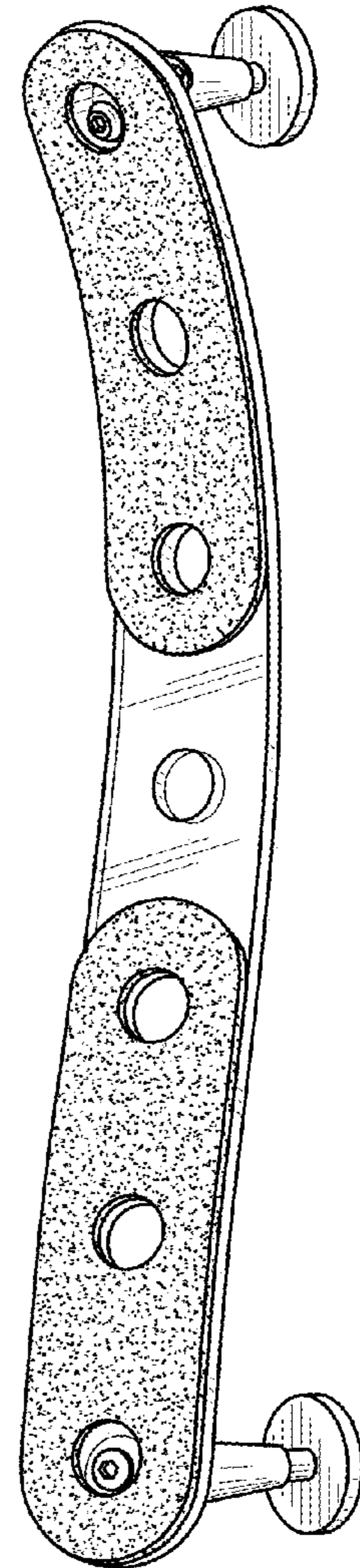

FIG. 7

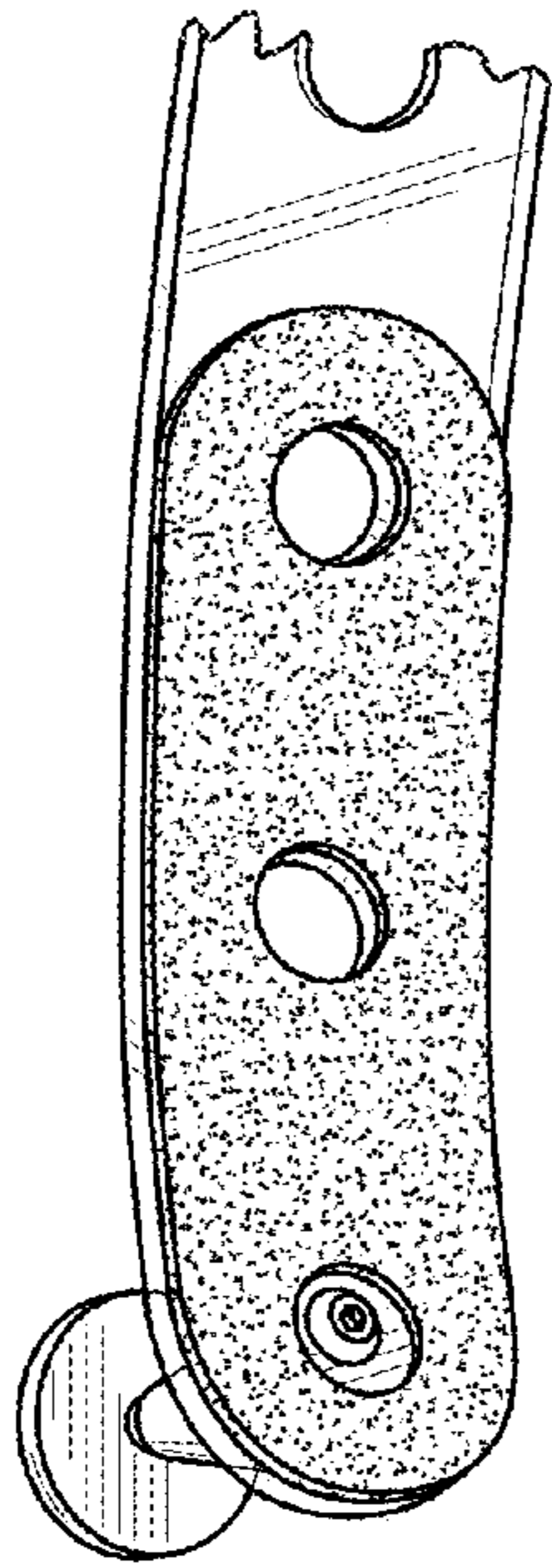

FIG. 8

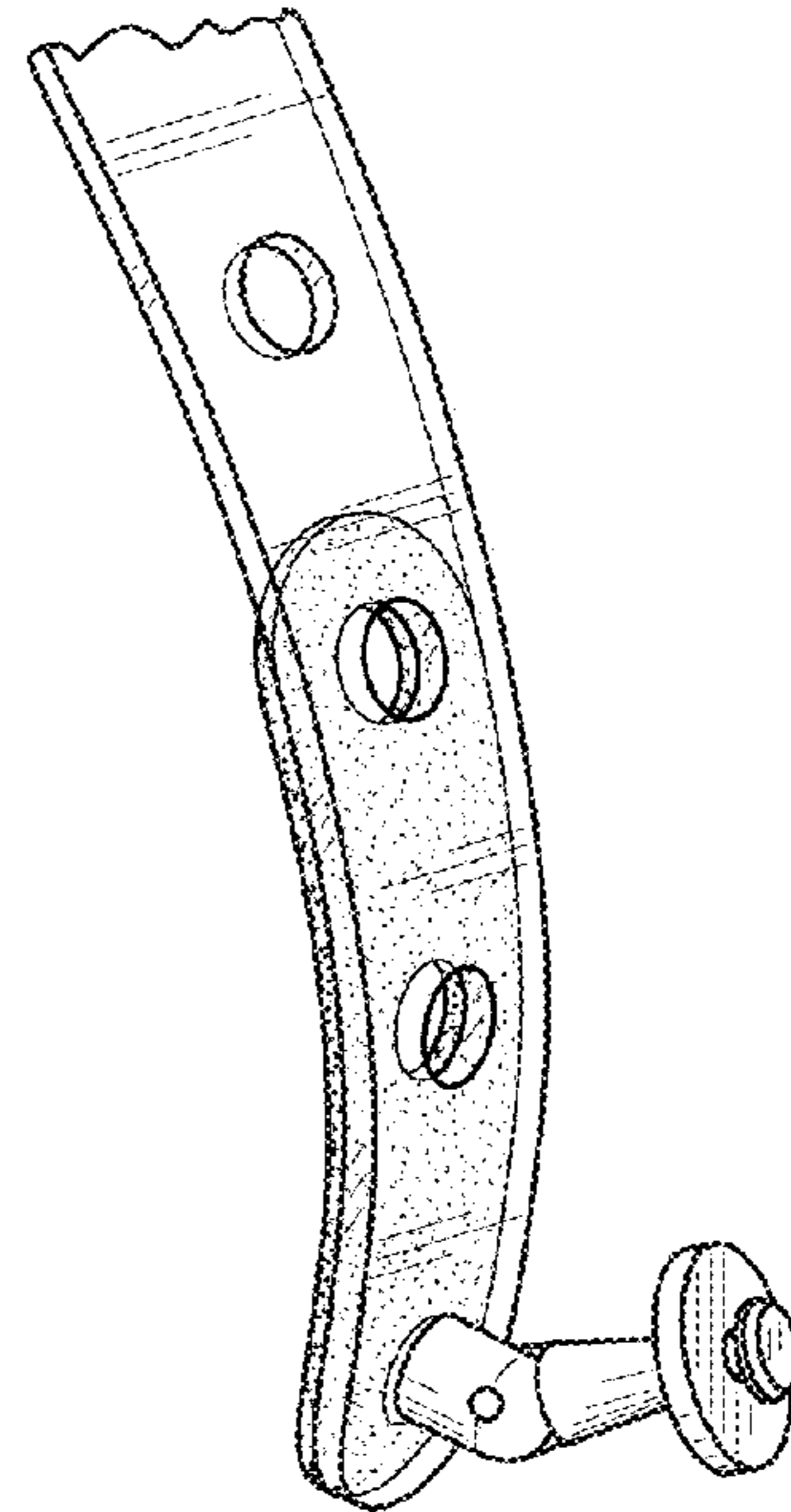

FIG. 9

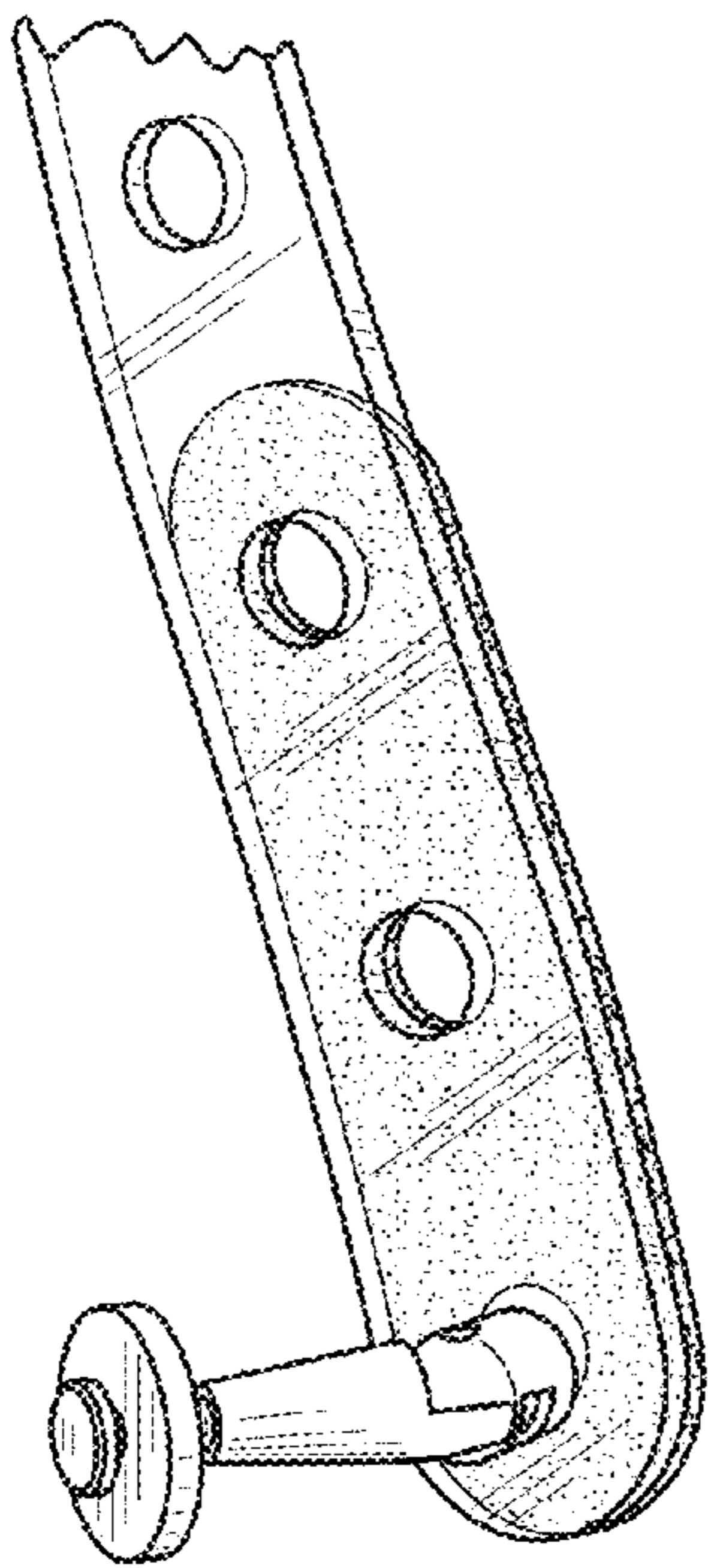

FIG. 10

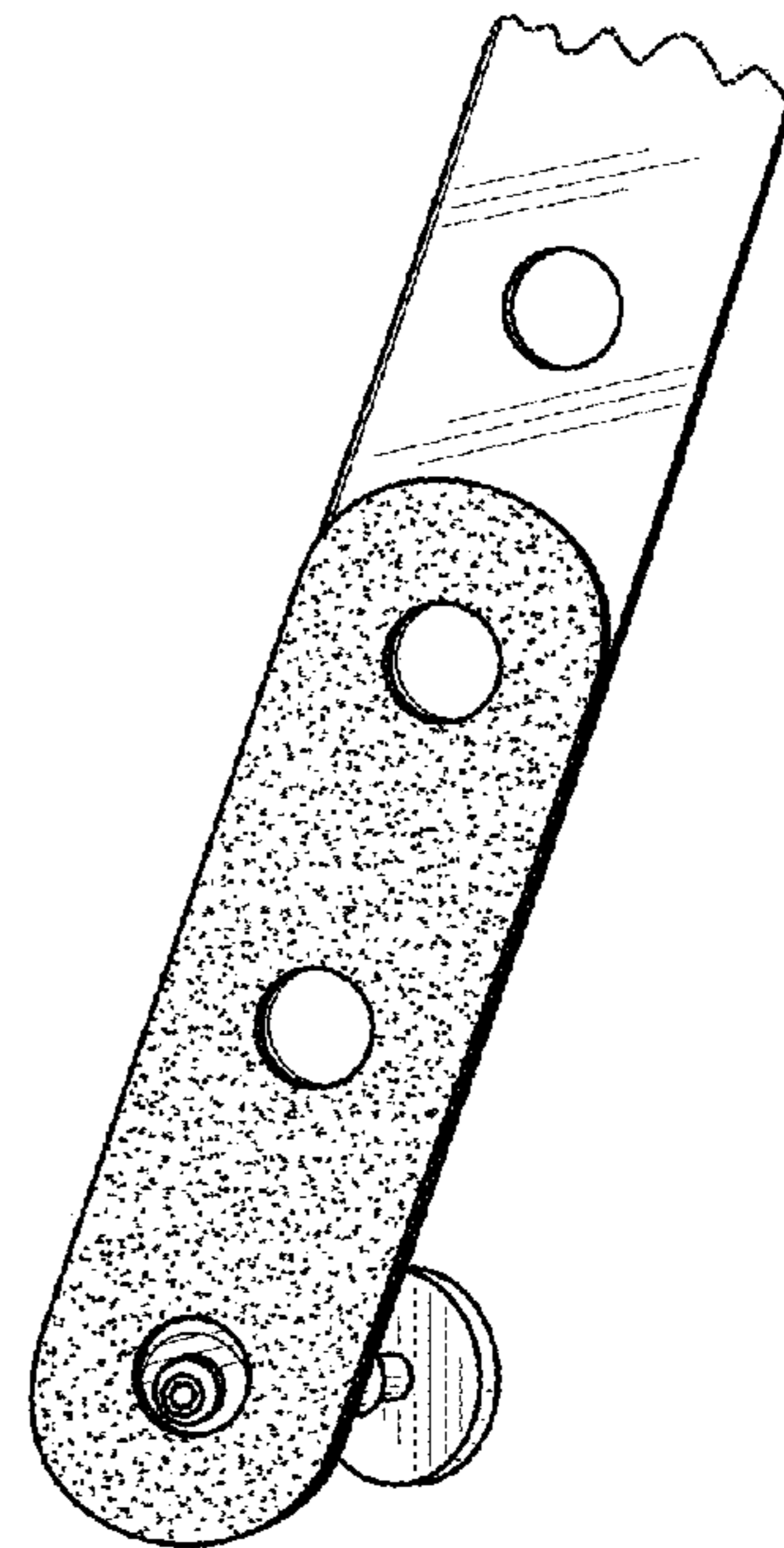

FIG. 11

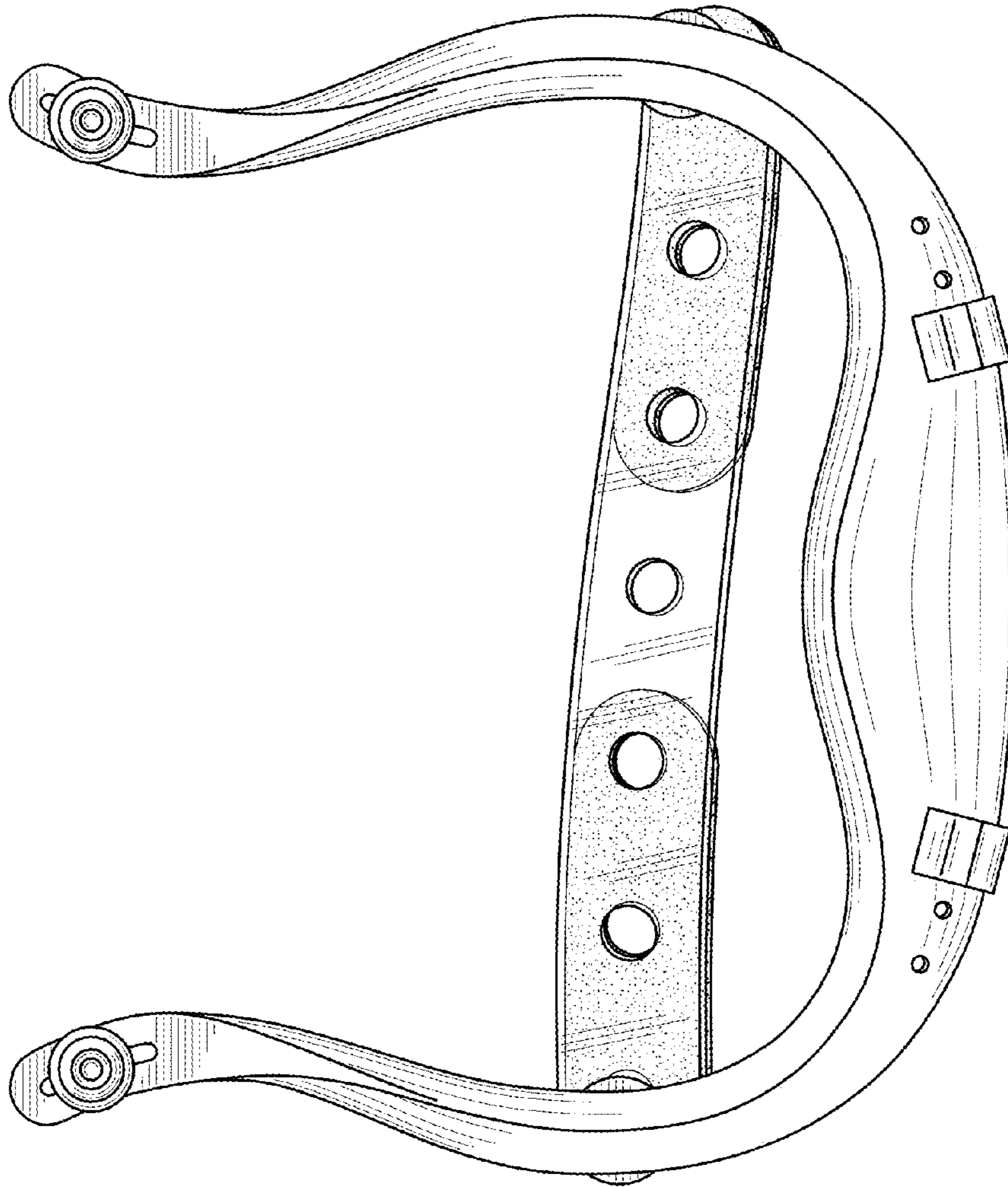

FIG. 12

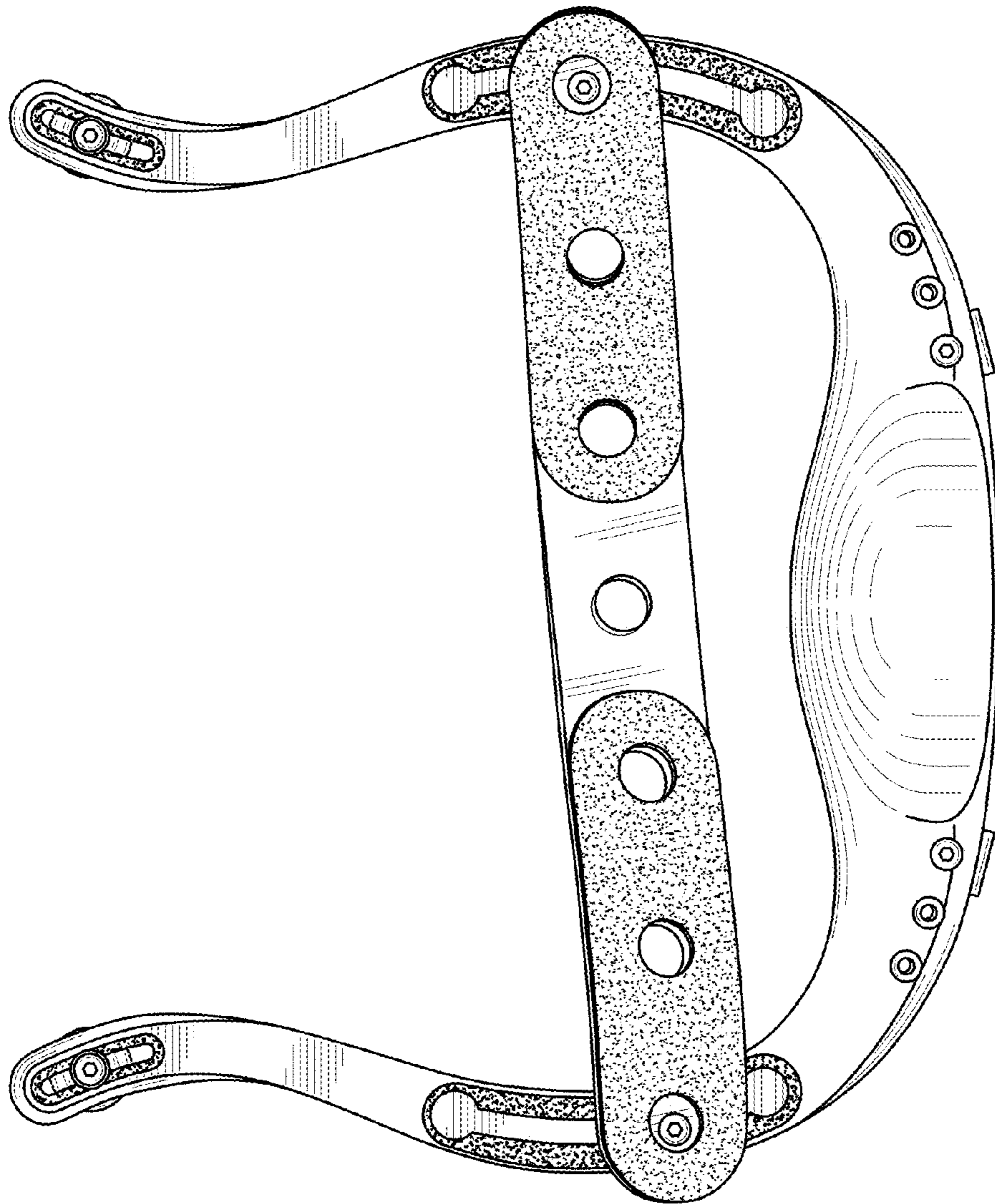
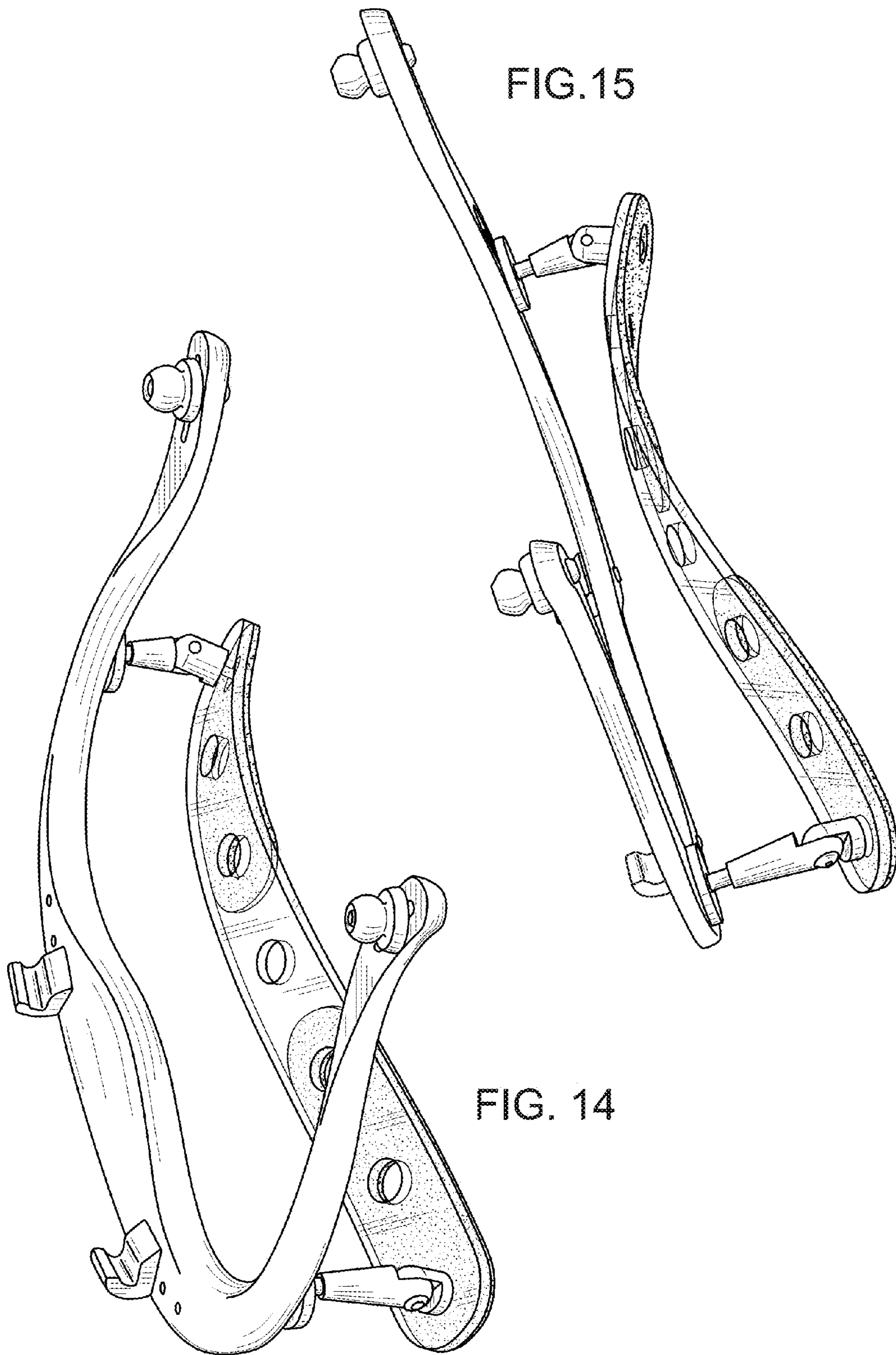

FIG. 13



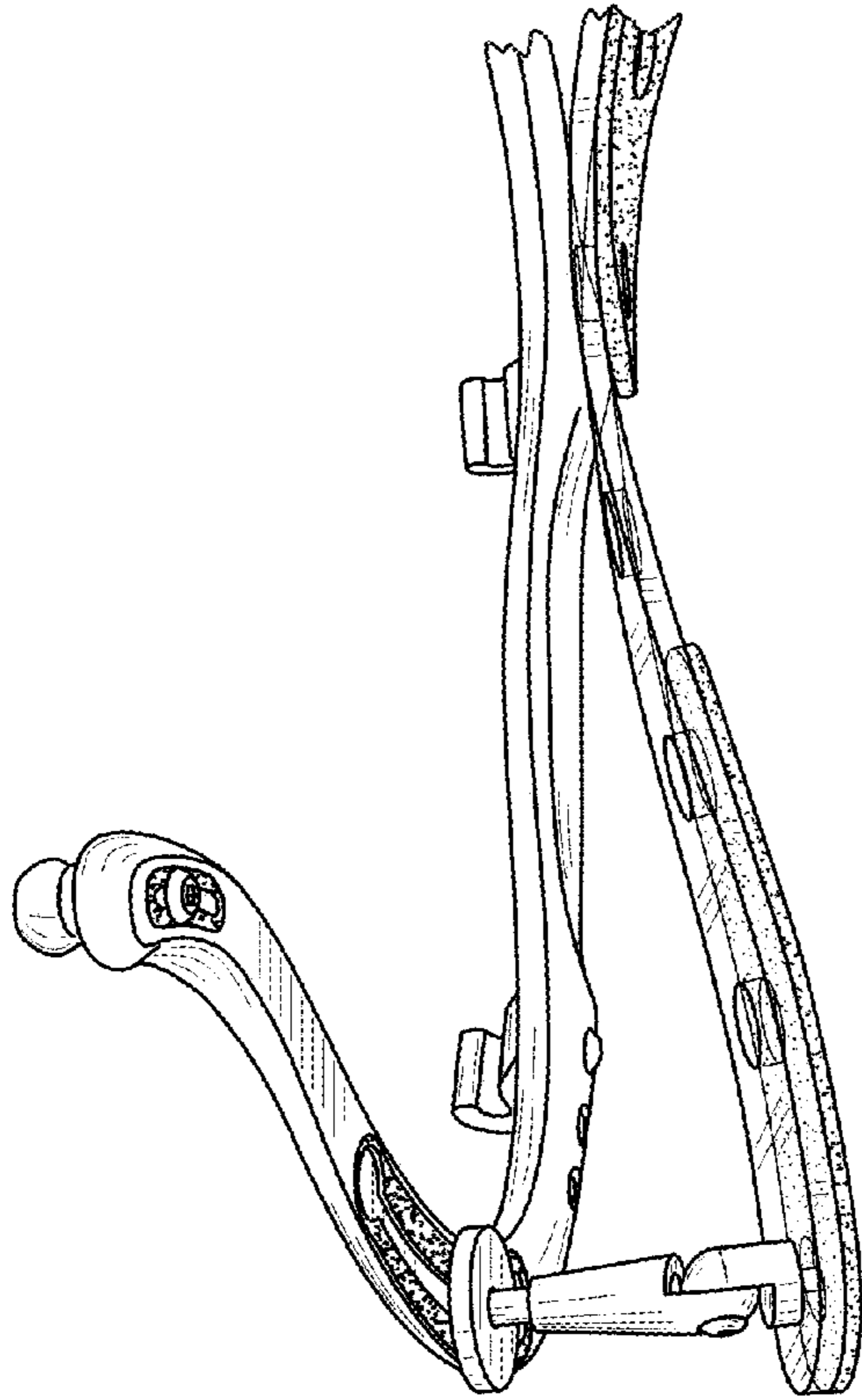

FIG. 16

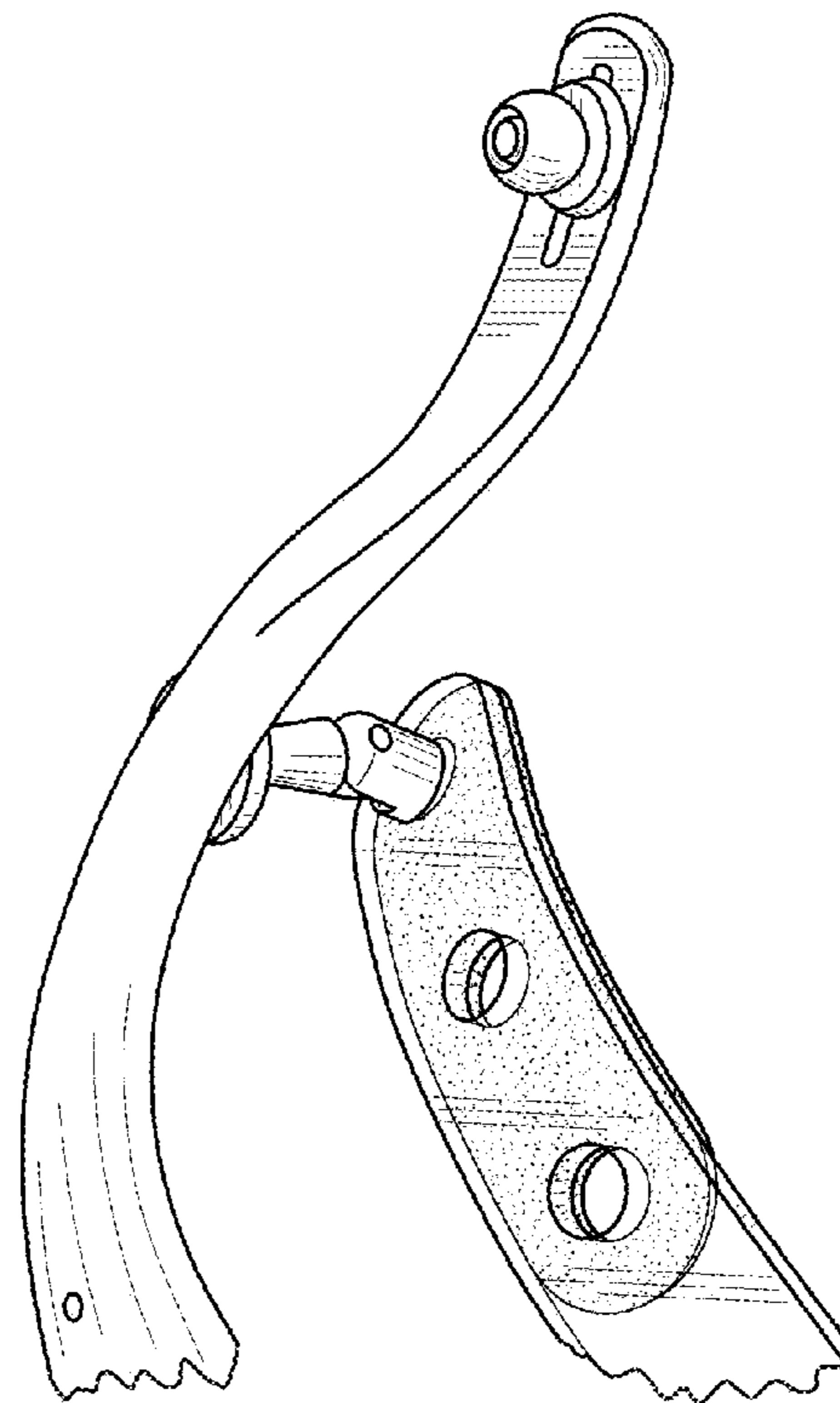

FIG. 17

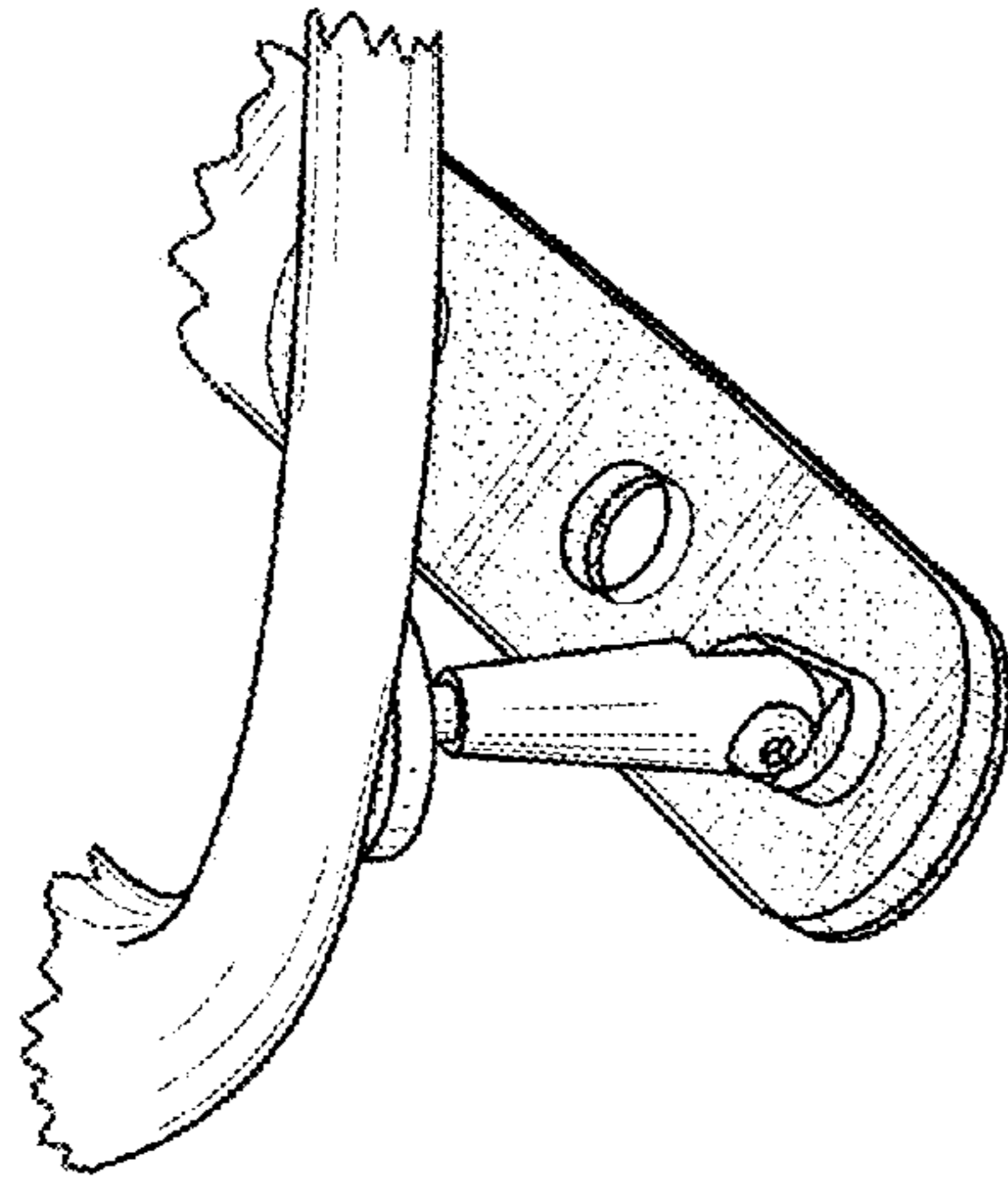

FIG. 18

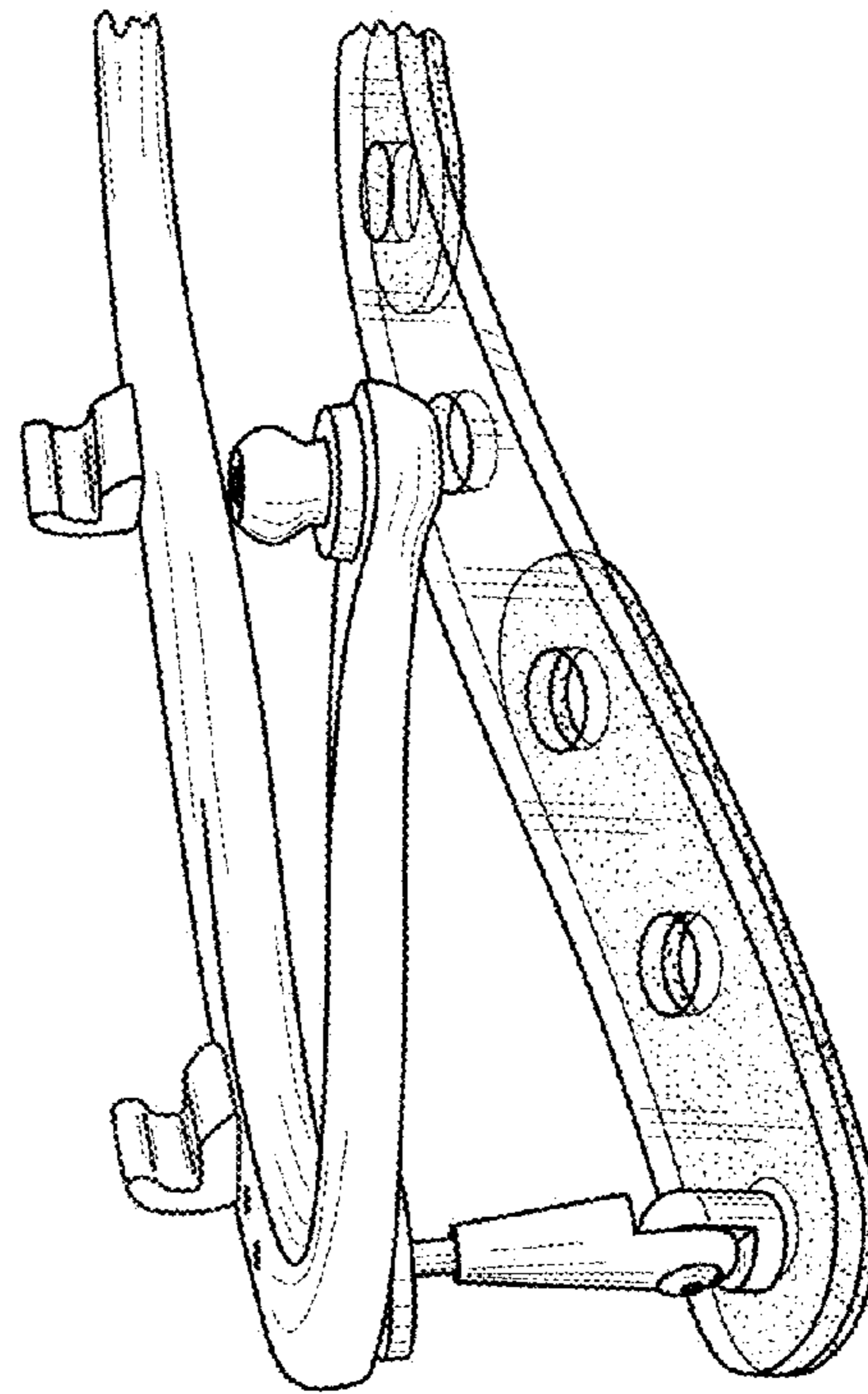

FIG. 19

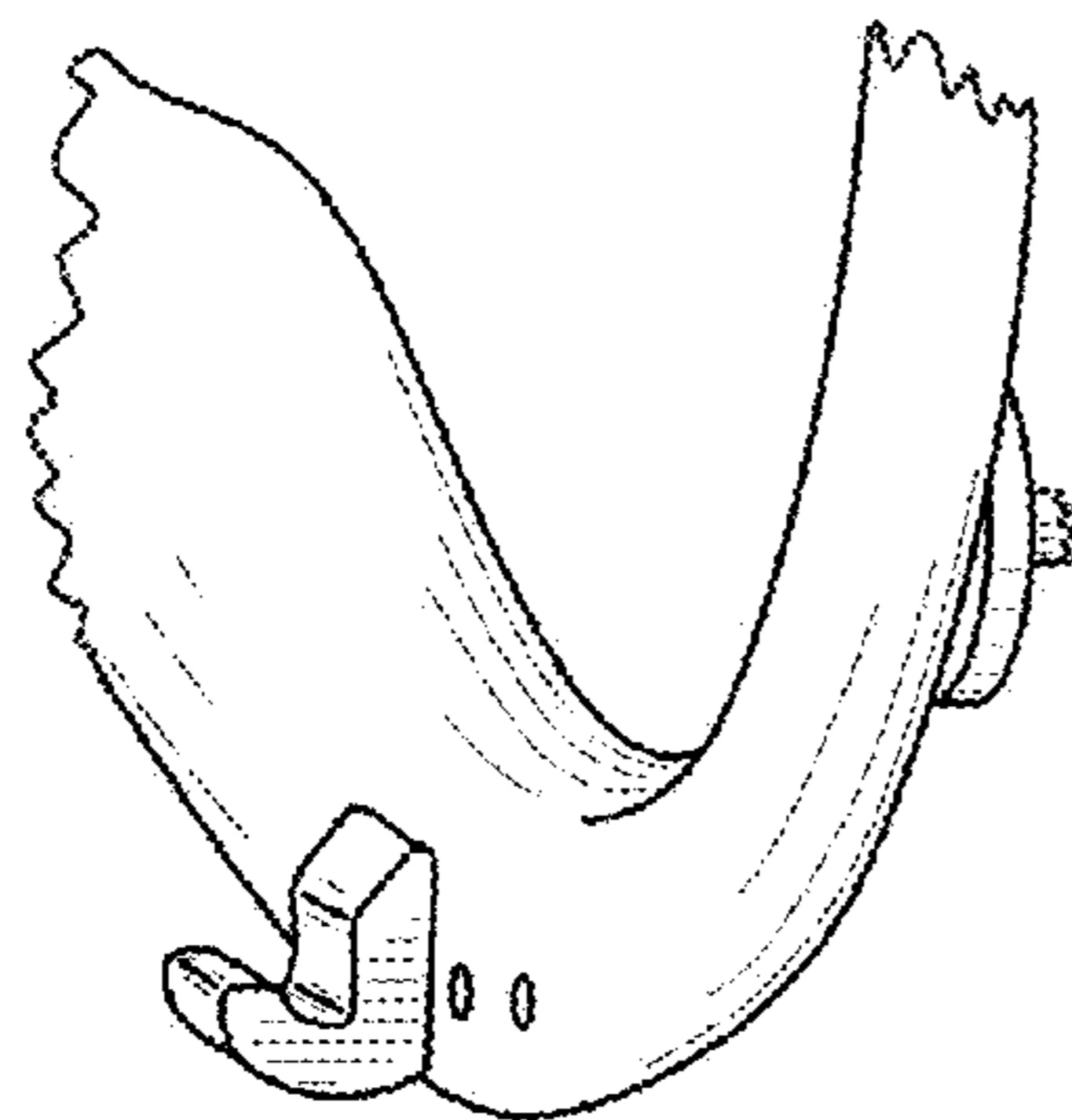

FIG. 20