



US00D716368S

(12) **United States Design Patent**
Uesugi et al.

(10) **Patent No.:** **US D716,368 S**
(45) **Date of Patent:** **** Oct. 28, 2014**

(54) **BENDER LEVER FOR AN ELECTRONIC MUSICAL INSTRUMENT**

D668,710 S * 10/2012 Okamura et al. D17/1

* cited by examiner

(71) Applicant: **Roland Corporation**, Shizuoka (JP)

Primary Examiner — Rashida Johnson

(74) *Attorney, Agent, or Firm* — Jianq Chyun IP Office

(72) Inventors: **Tetsuya Uesugi**, Shizuoka (JP); **Hitoshi Sato**, Shizuoka (JP)

(57) **CLAIM**

The ornamental design for a bender lever for an electronic musical instrument, as shown and described.

(73) Assignee: **Roland Corporation**, Shizuoka (JP)

DESCRIPTION

(**) Term: **14 Years**

(21) Appl. No.: **29/465,526**

FIG. 1 is a perspective view of a bender lever for an electronic musical instrument showing a first embodiment of our new design;

(22) Filed: **Aug. 29, 2013**

FIG. 2 is a front view of the first embodiment;

(51) **LOC (10) Cl.** **17-01**

FIG. 3 is a rear view of the first embodiment;

(52) **U.S. Cl.**

USPC **D17/9**

FIG. 4 is a left side view of the first embodiment;

(58) **Field of Classification Search**

USPC D17/1, 2, 7-9; 84/13, 19, 423 R, 424, 84/426, 427, 443, 719, 720, 744, 745; D21/409

FIG. 5 is a right side view of the first embodiment;

FIG. 6 is a top view of the first embodiment;

FIG. 7 is a bottom view of the first embodiment;

FIG. 8 is a reduced perspective view of the first embodiment, in a state of use;

See application file for complete search history.

FIG. 9 is a perspective view of a bender lever for an electronic musical instrument showing a second embodiment of our new design;

(56) **References Cited**

U.S. PATENT DOCUMENTS

D369,175 S *	4/1996	Nakada	D17/1
D508,070 S *	8/2005	Tanaka	D17/1
D510,381 S *	10/2005	Okamura et al.	D17/1
D552,158 S *	10/2007	Tanaka	D17/1
D555,712 S *	11/2007	Sato	D17/1
D557,327 S *	12/2007	Onishi et al.	D17/1
D558,255 S *	12/2007	Reichhuber	D17/1
D585,478 S *	1/2009	Takei	D17/1
D636,013 S *	4/2011	Shin et al.	D17/1
D667,867 S *	9/2012	Kitazawa	D17/1
D668,287 S *	10/2012	Kitazawa	D17/1
D668,709 S *	10/2012	Williamson et al.	D17/1

FIG. 10 is a front view of the second embodiment;

FIG. 11 is a rear view of the second embodiment;

FIG. 12 is a left side view of the second embodiment;

FIG. 13 is a right side view of the second embodiment;

FIG. 14 is a top view of the second embodiment;

FIG. 15 is a bottom view of the second embodiment; and,

FIG. 16 is a reduced perspective view of the second embodiment, in a state of use.

The broken line showings of the bender levers in FIGS. 1-7 and 9-15 and the electronic musical instruments in FIGS. 8 and 16 are included for the purpose of illustrating portions of the bender lever and environmental structure and form no part of the claimed design.

1 Claim, 10 Drawing Sheets

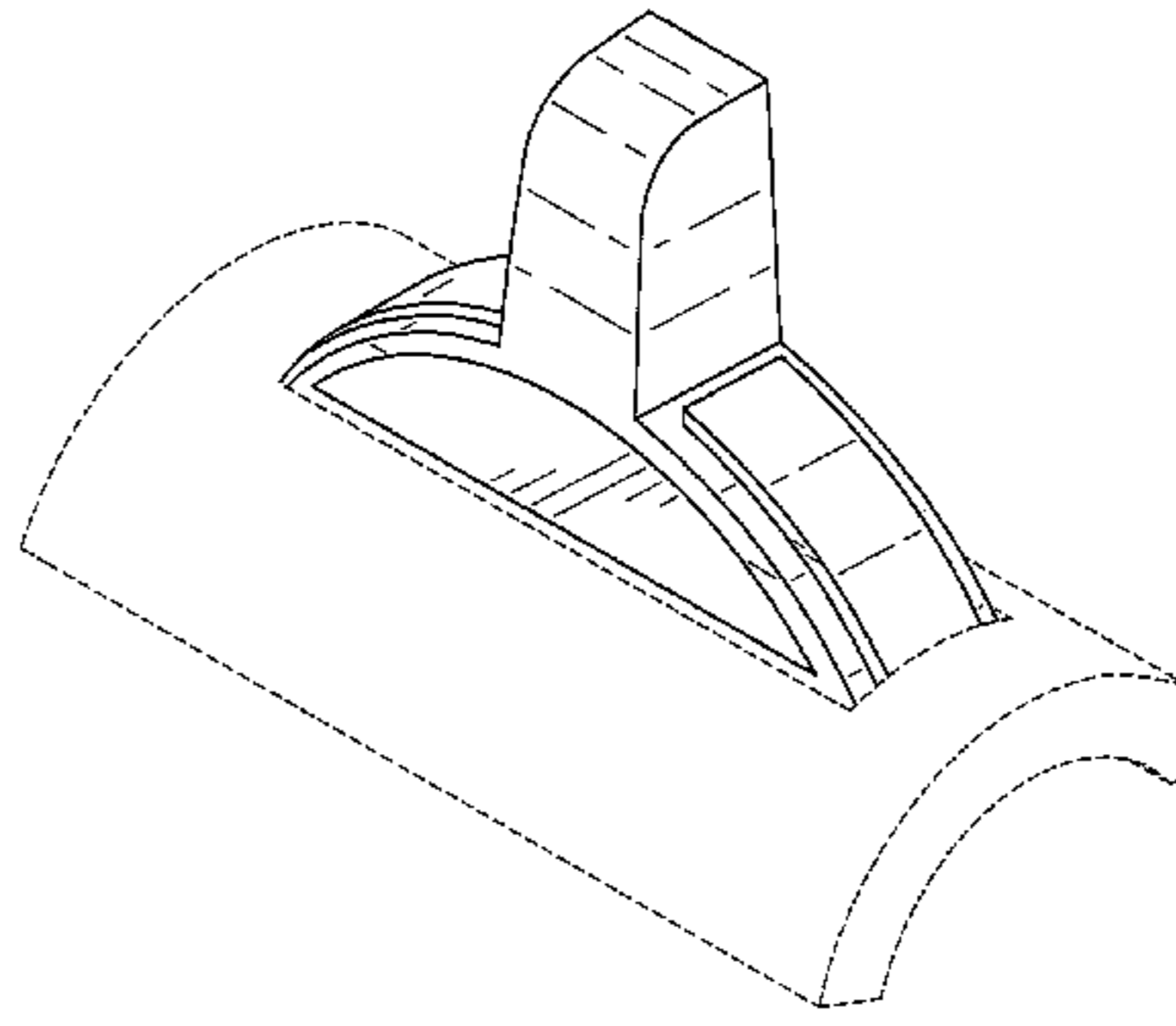
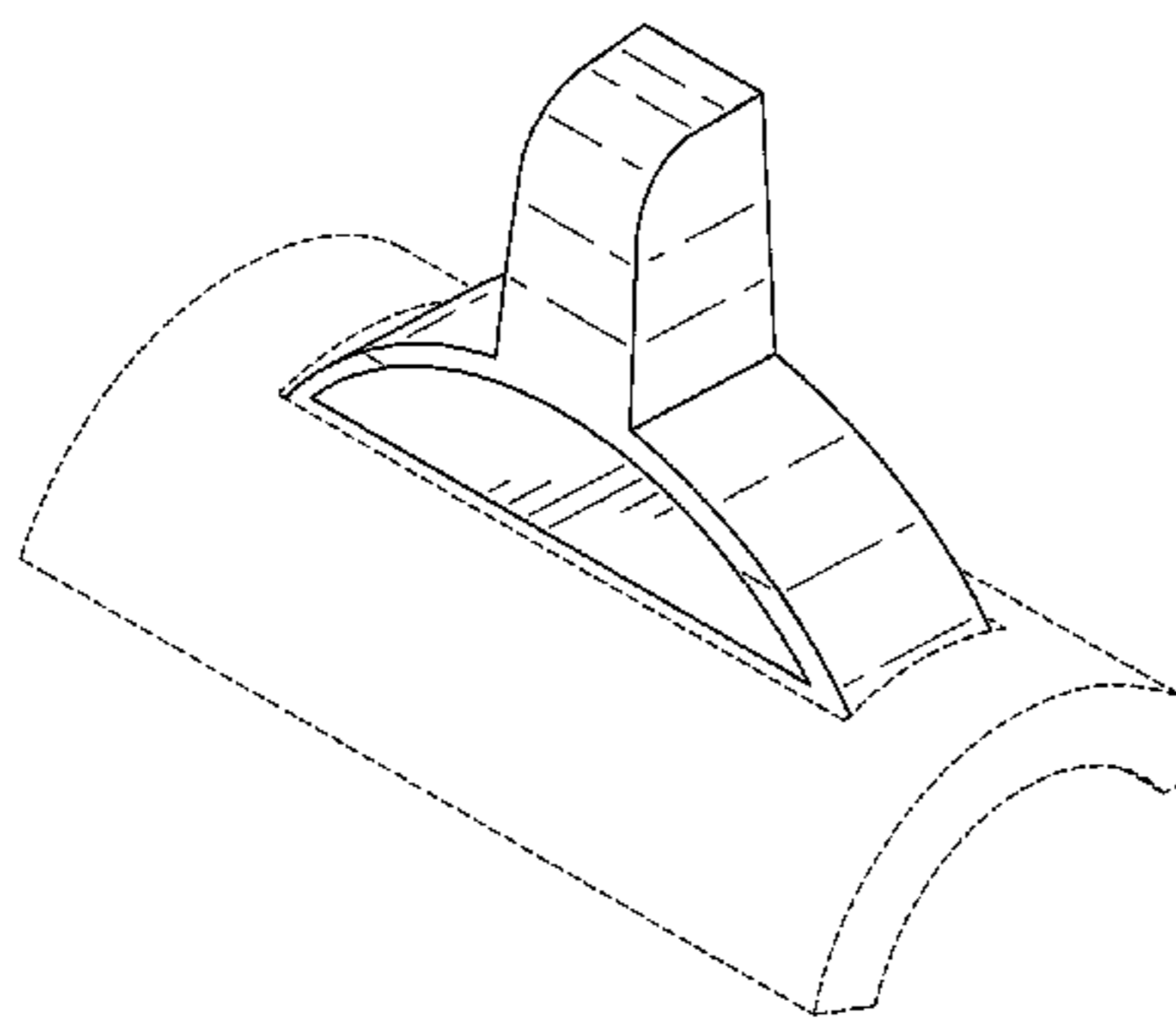

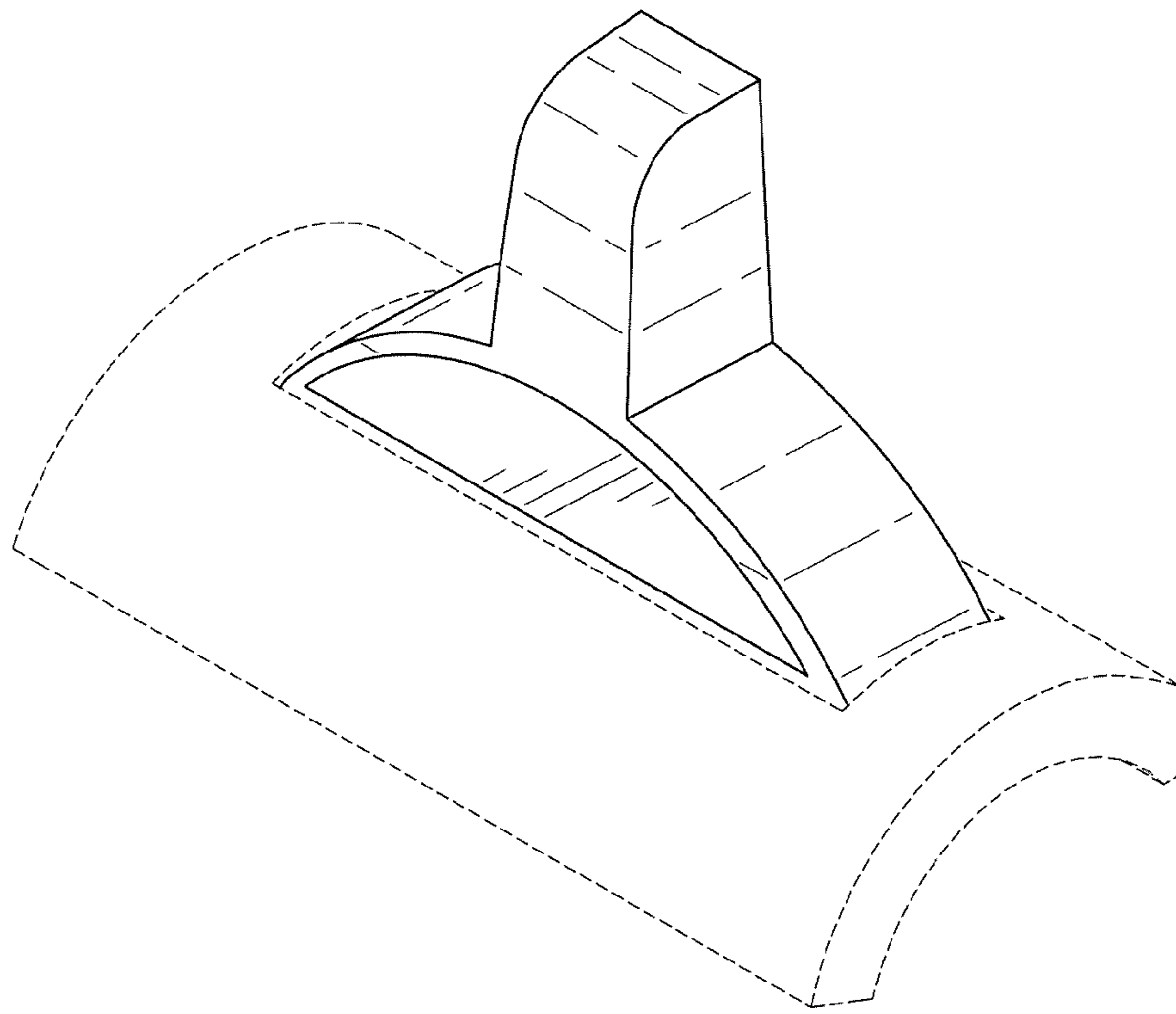

FIG. 1

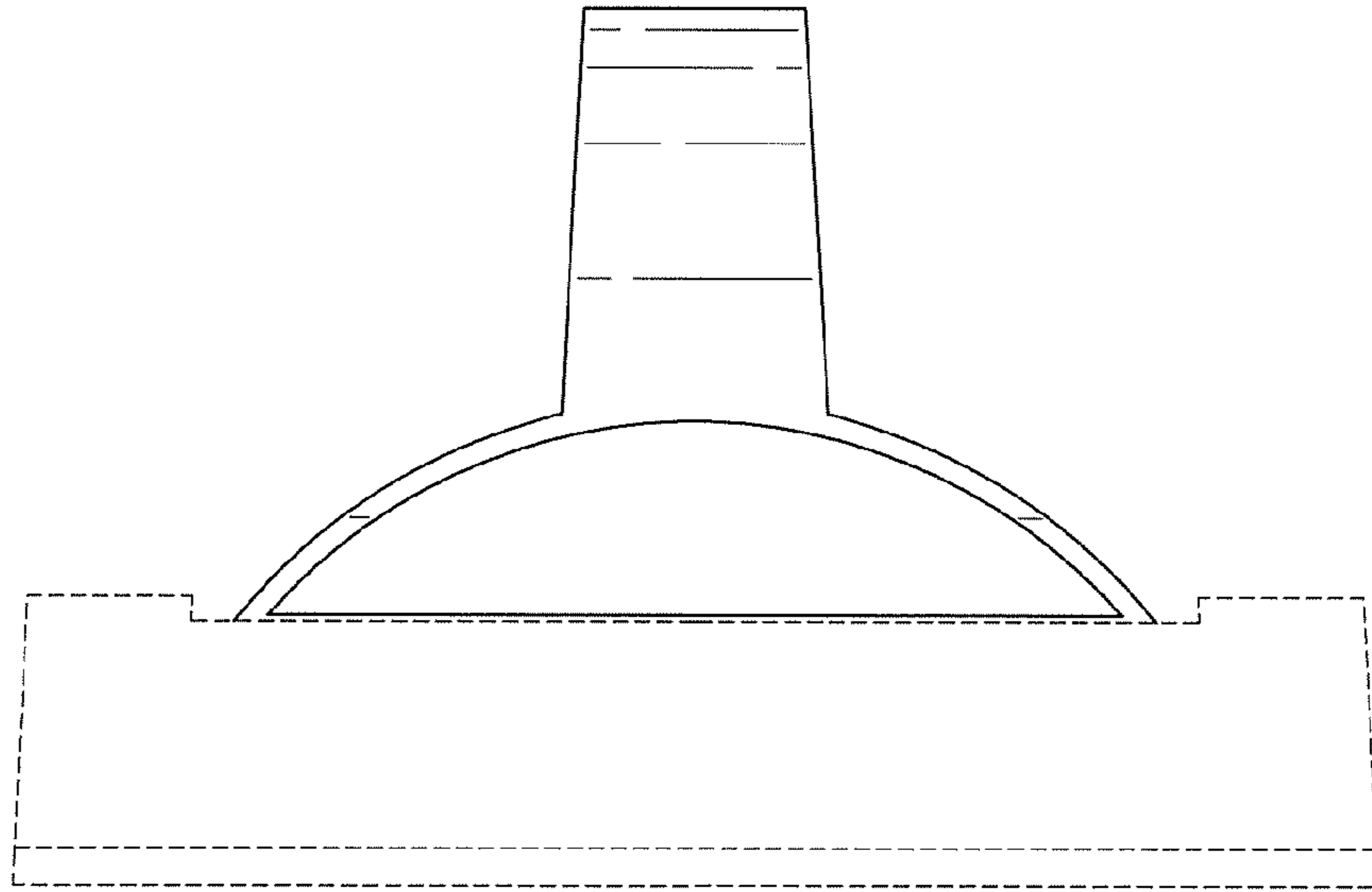

FIG. 2

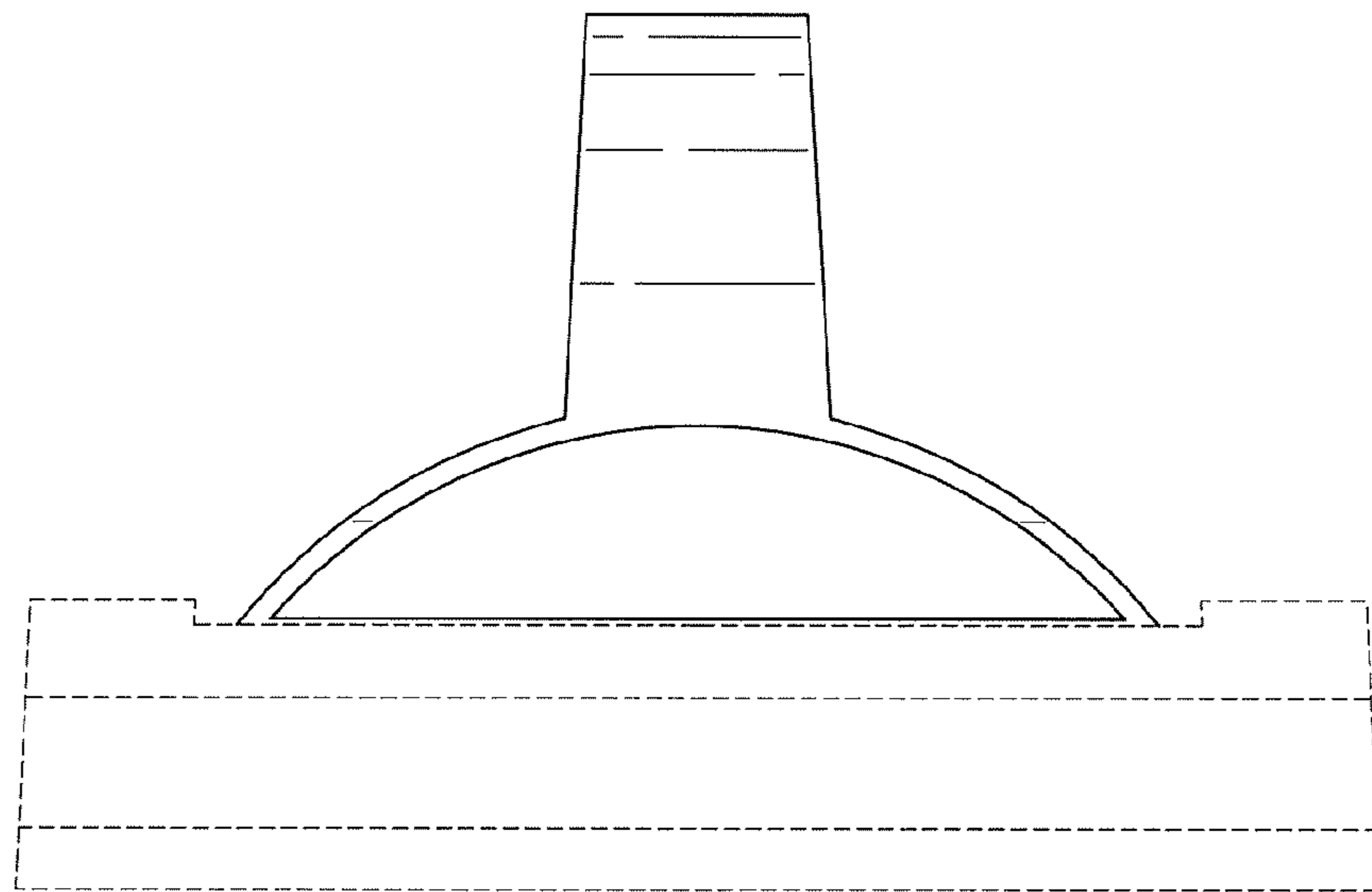

FIG. 3

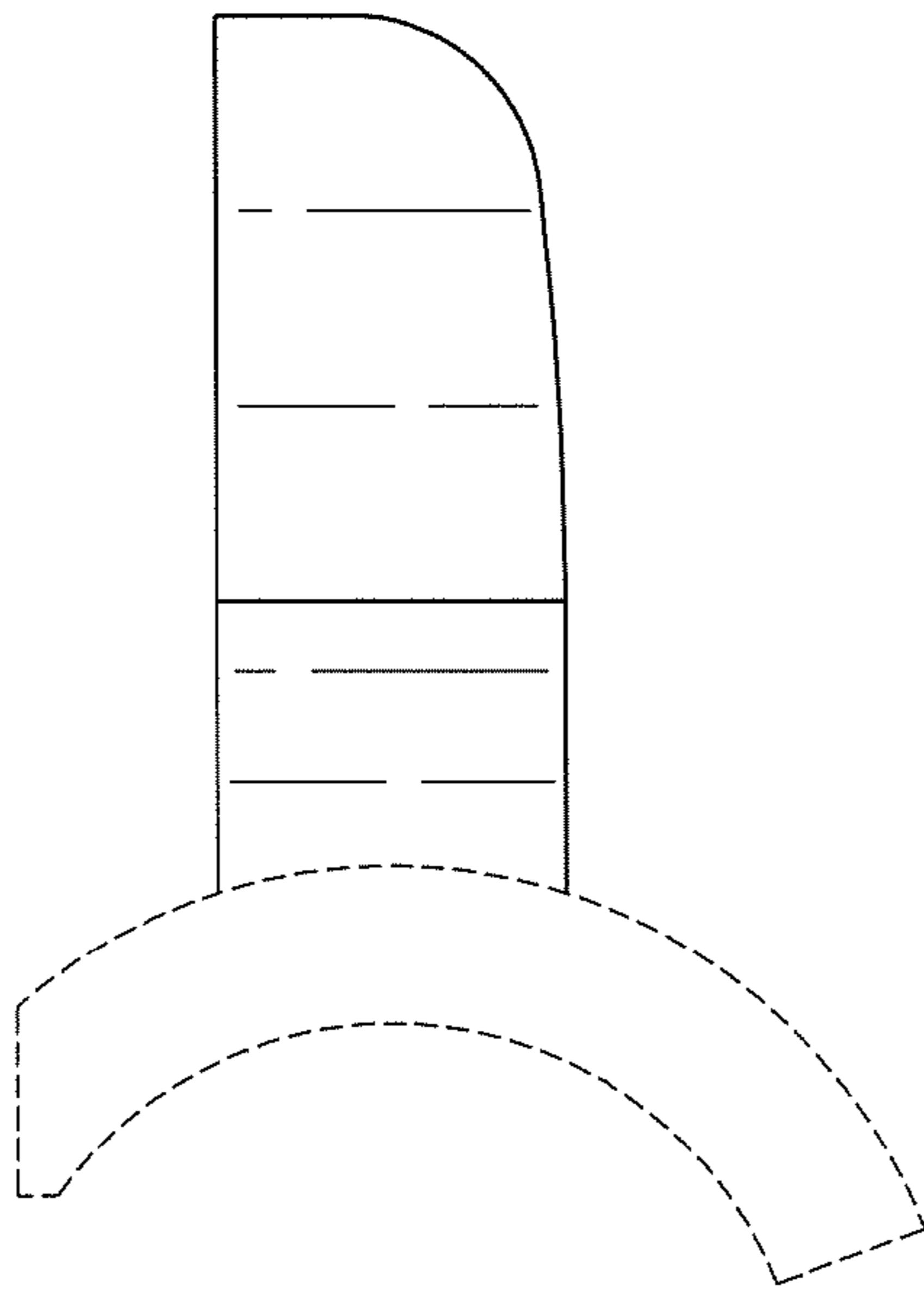

FIG. 4

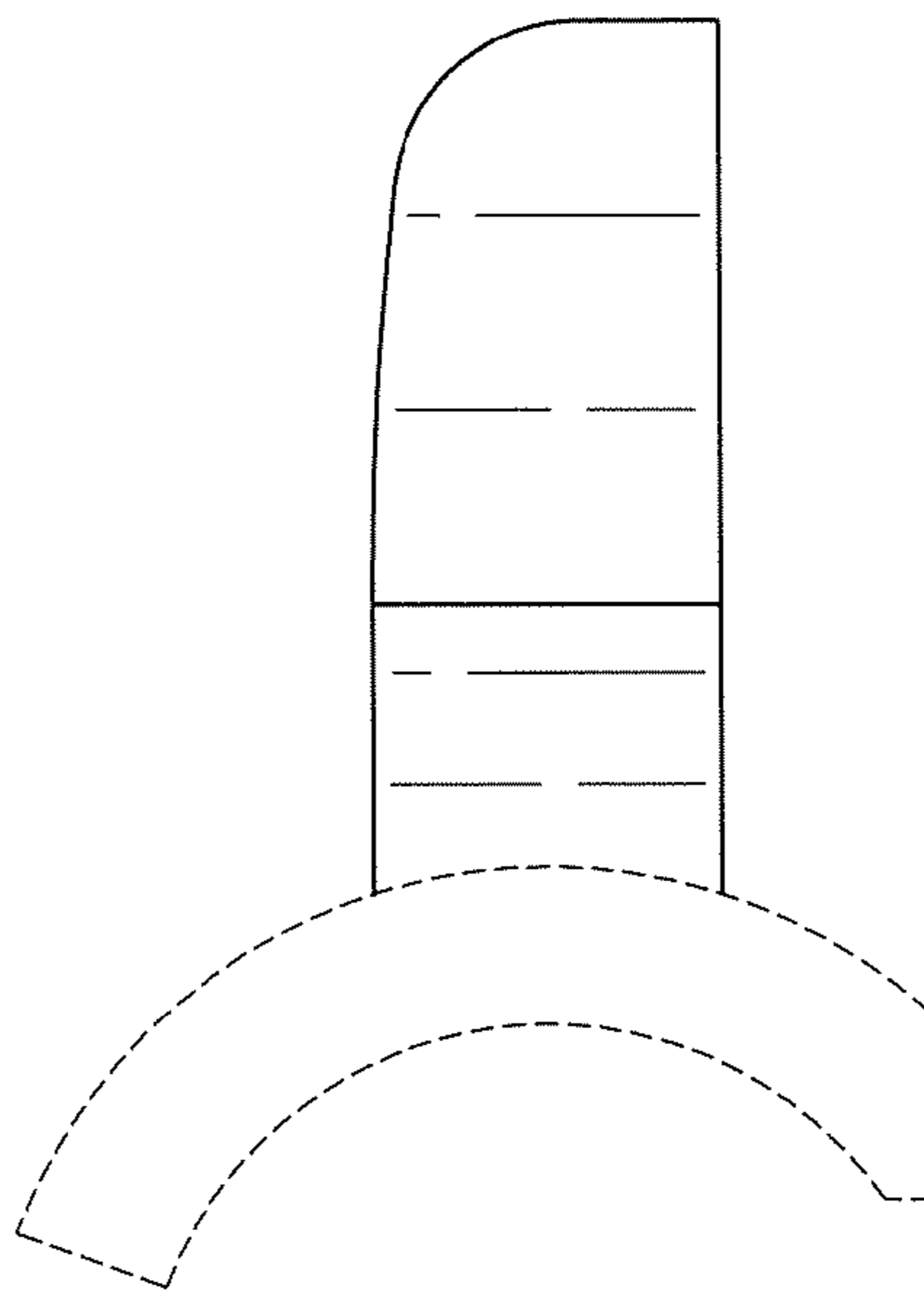

FIG. 5

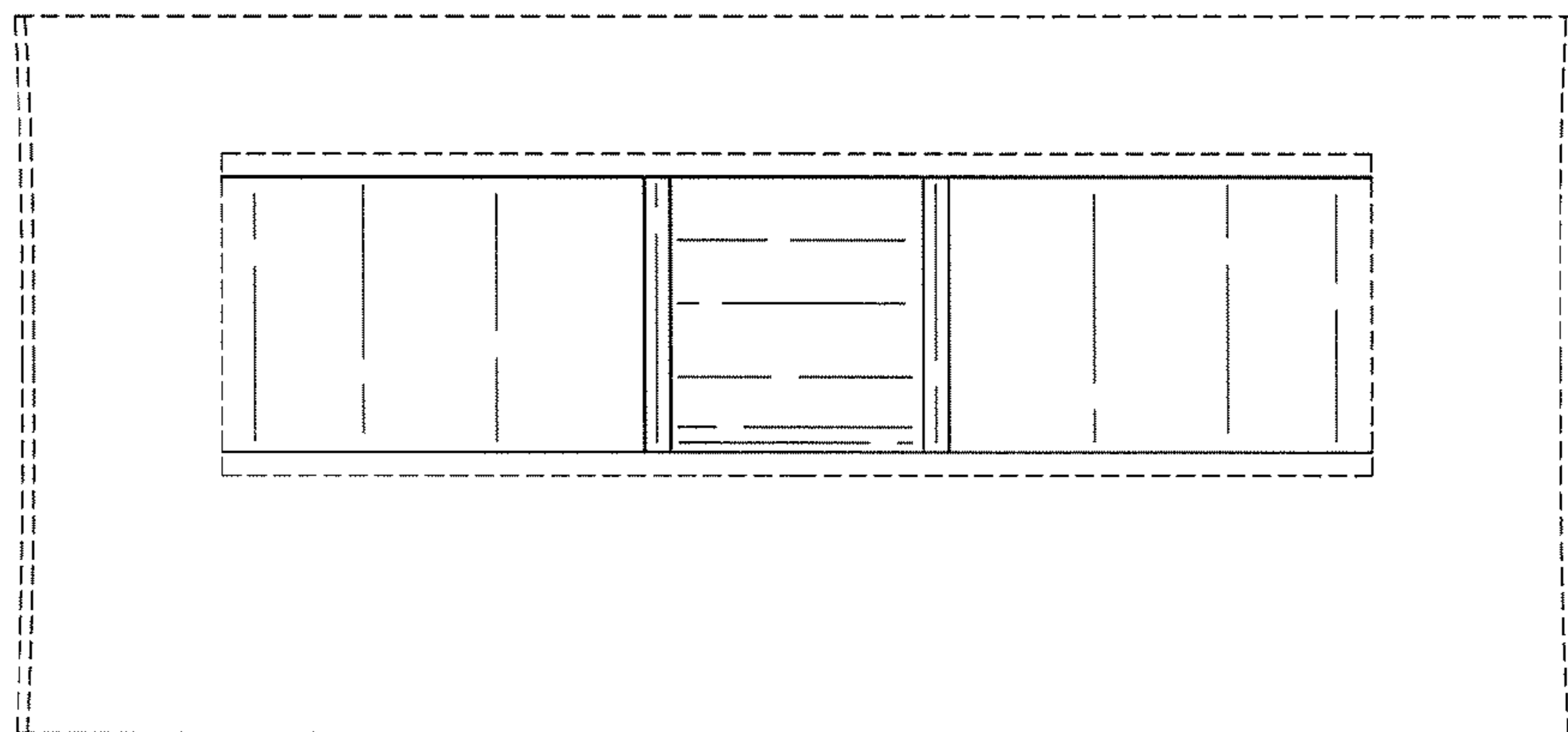

FIG. 6

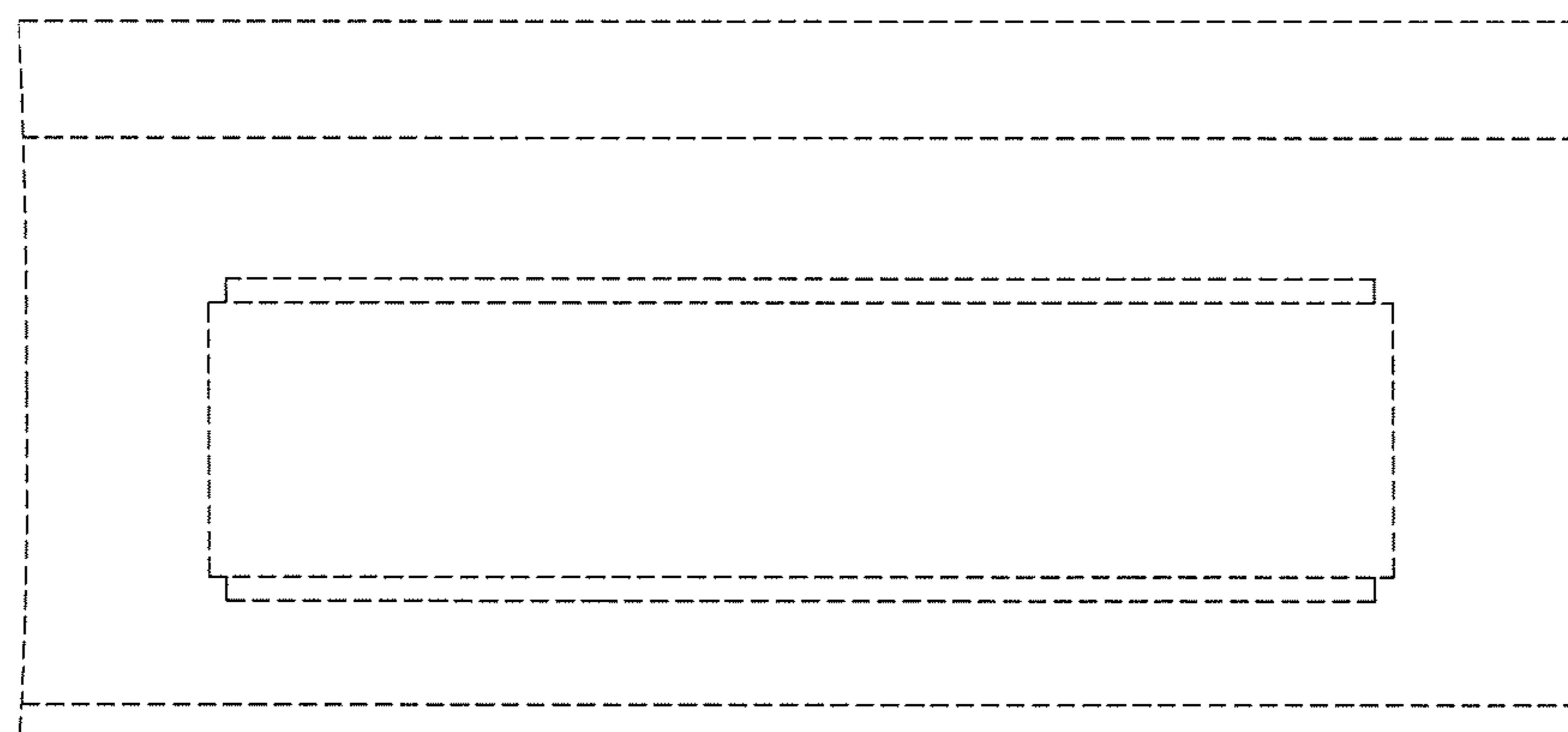

FIG. 7

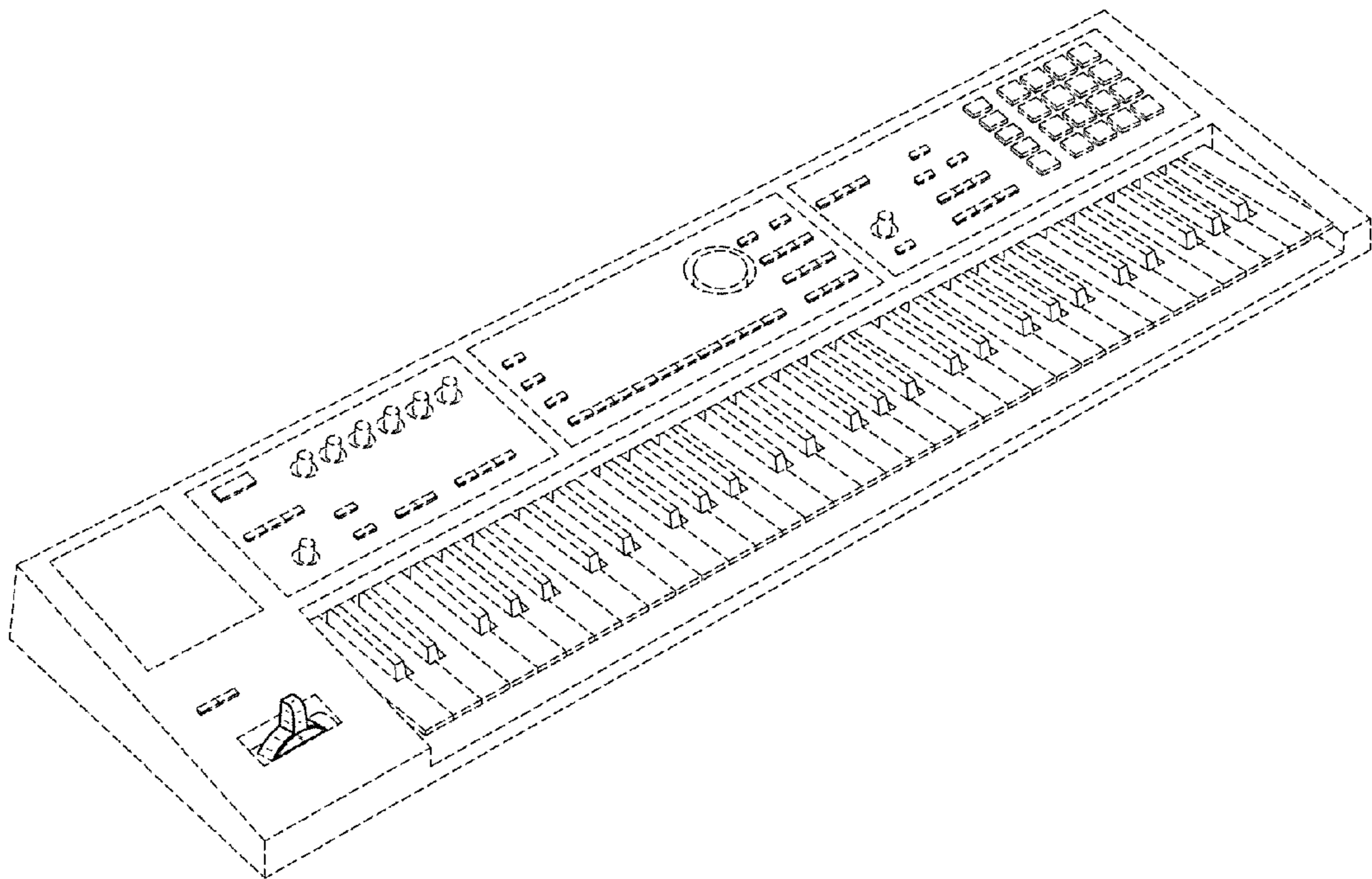

FIG. 8

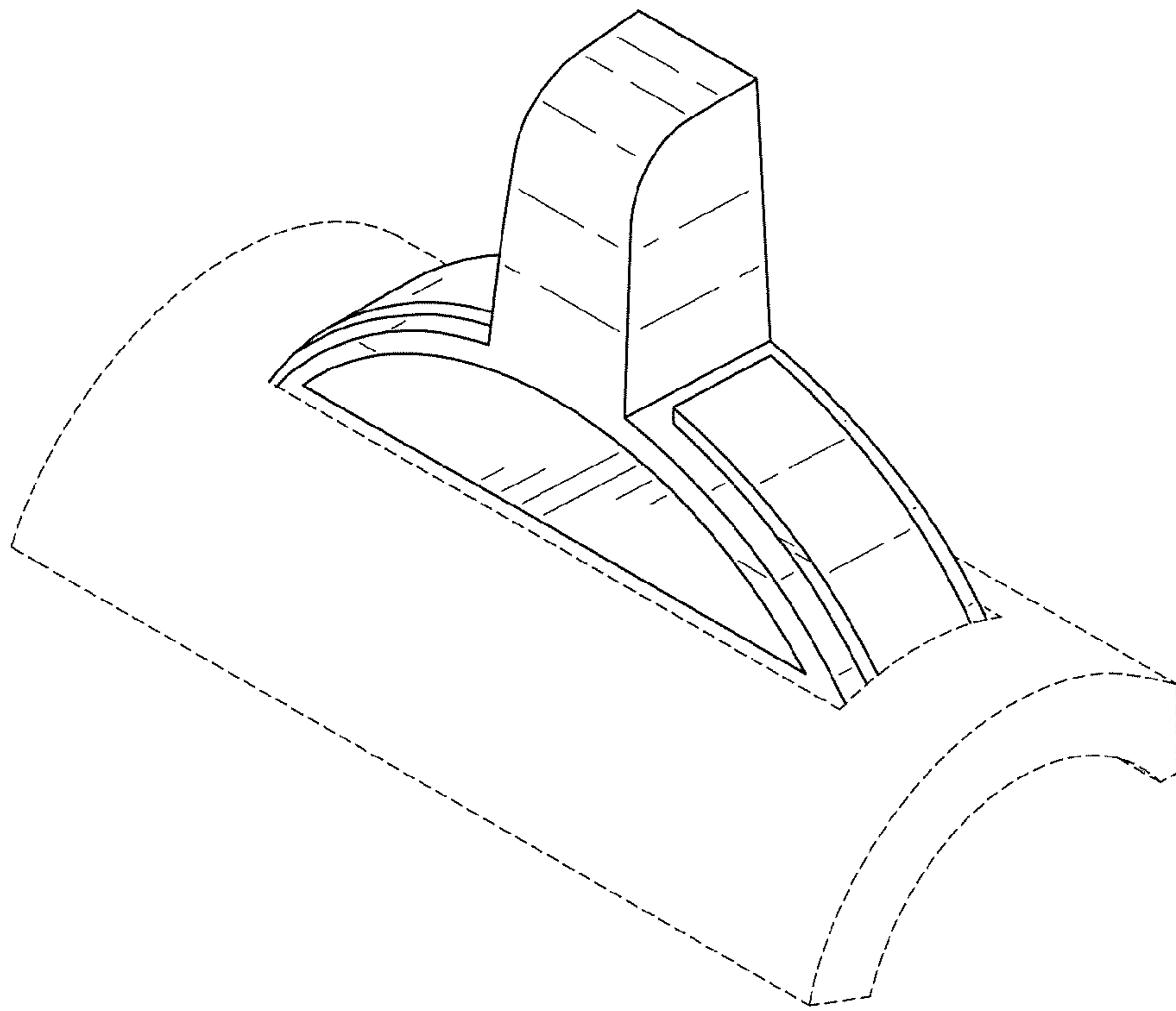

FIG. 9

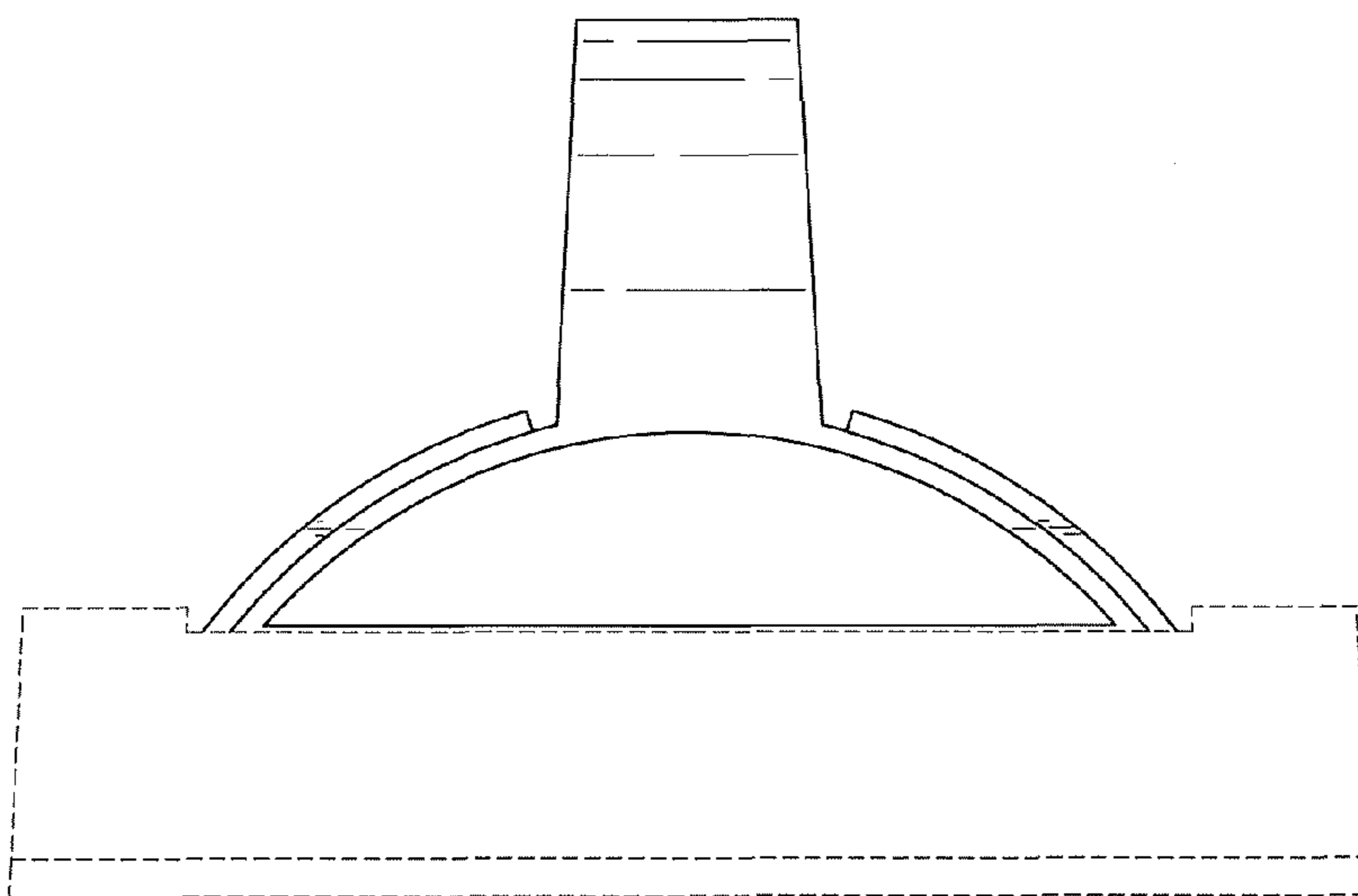

FIG. 10

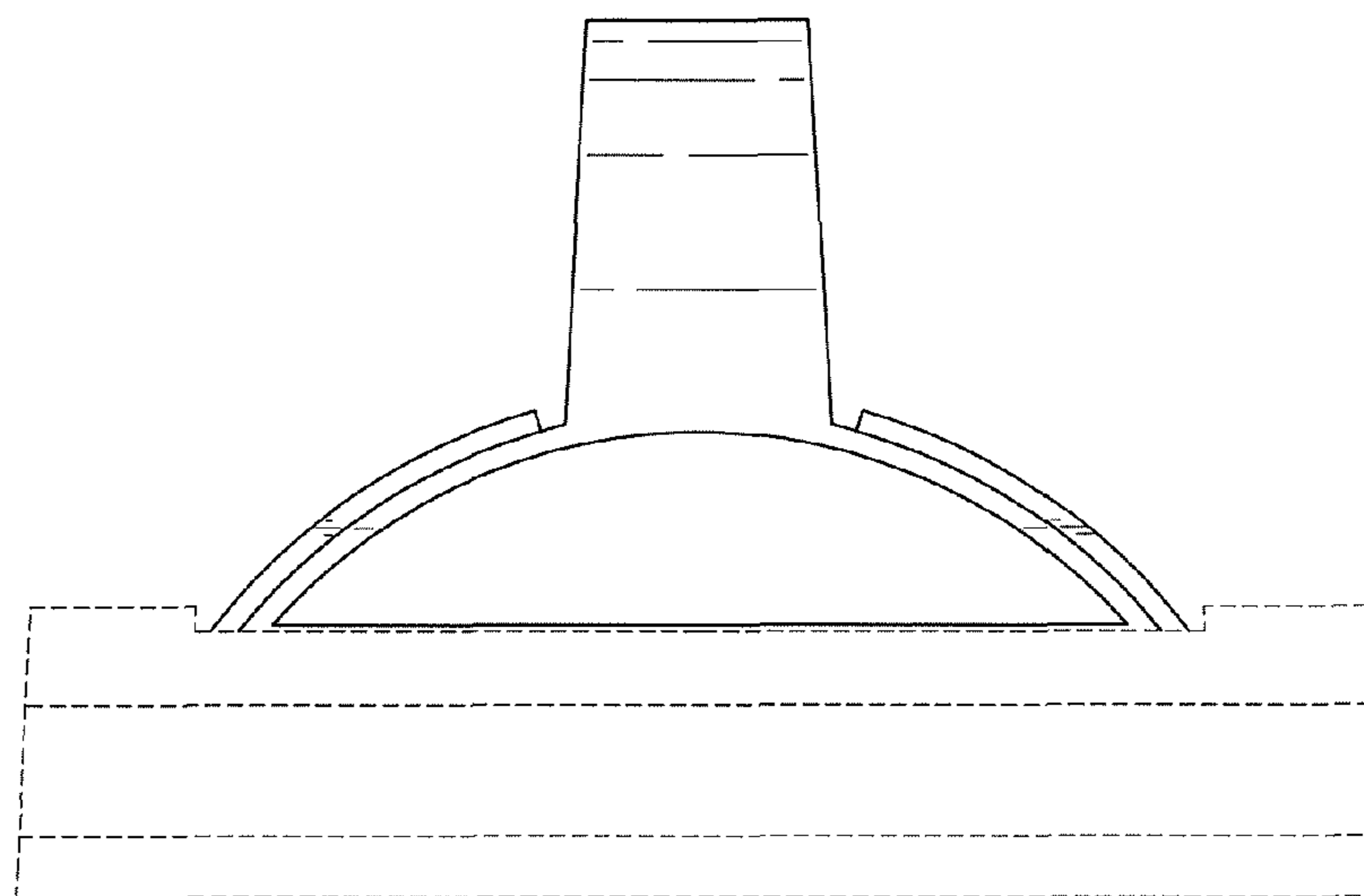

FIG. 11

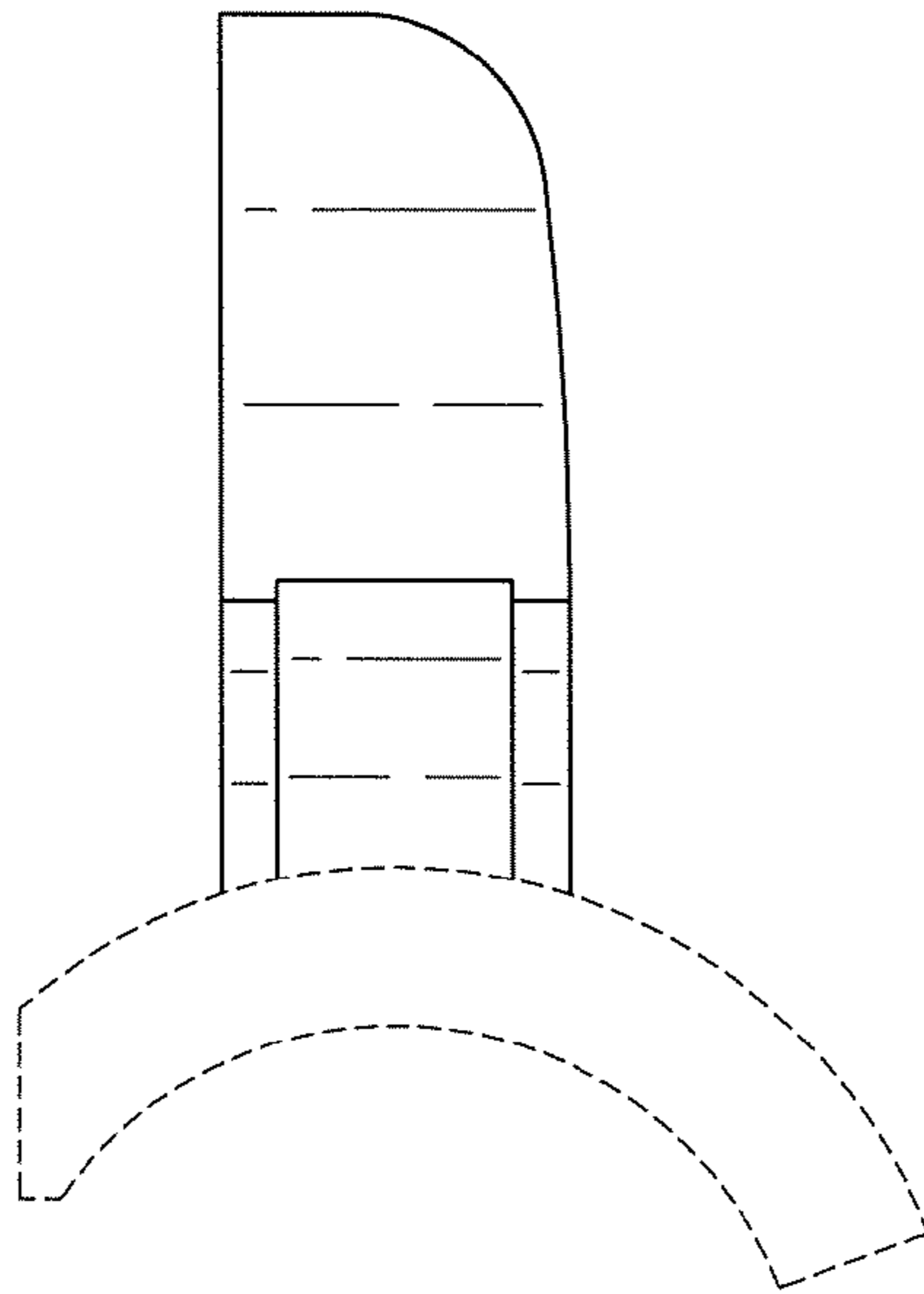

FIG. 12

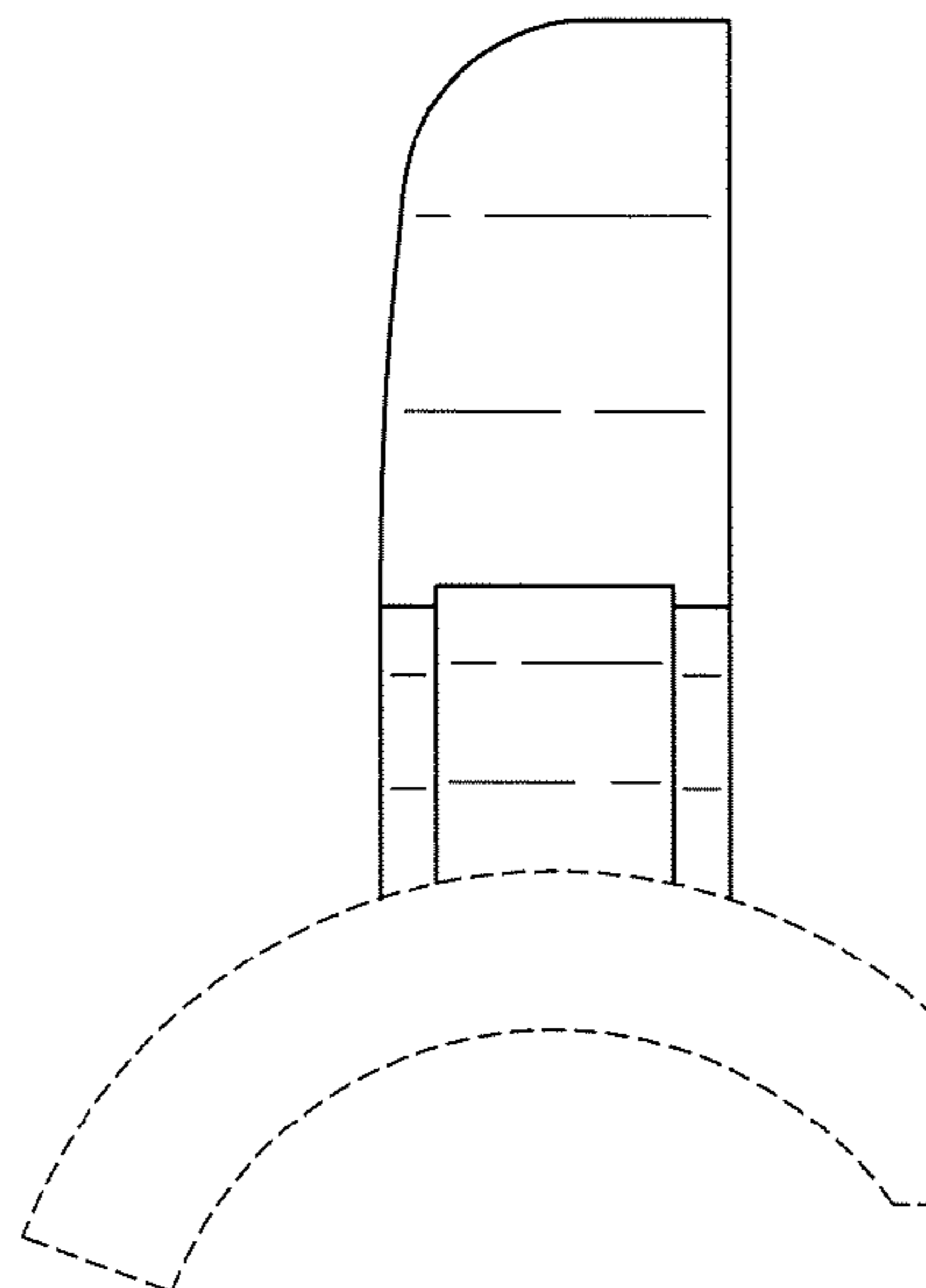

FIG. 13

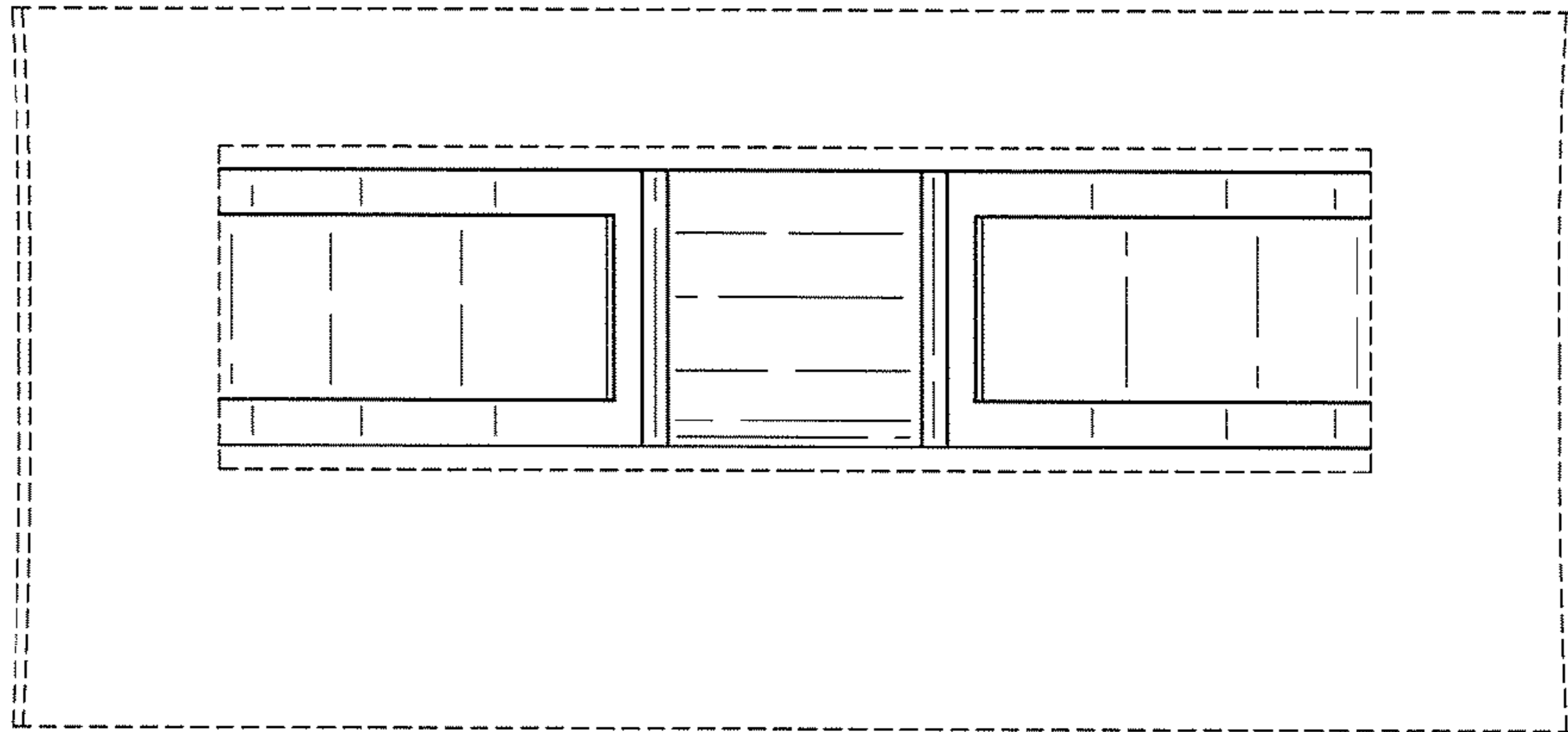

FIG. 14

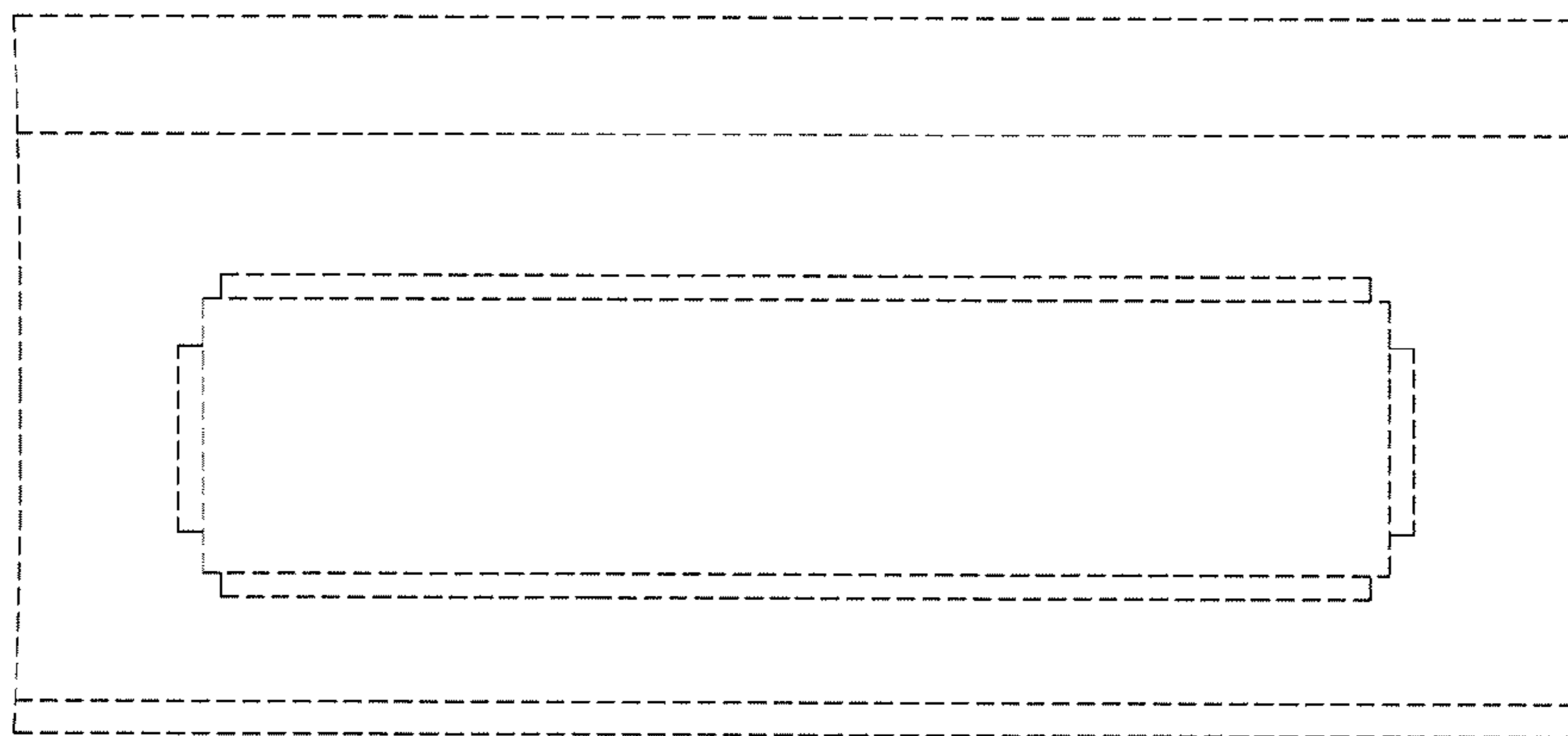

FIG. 15

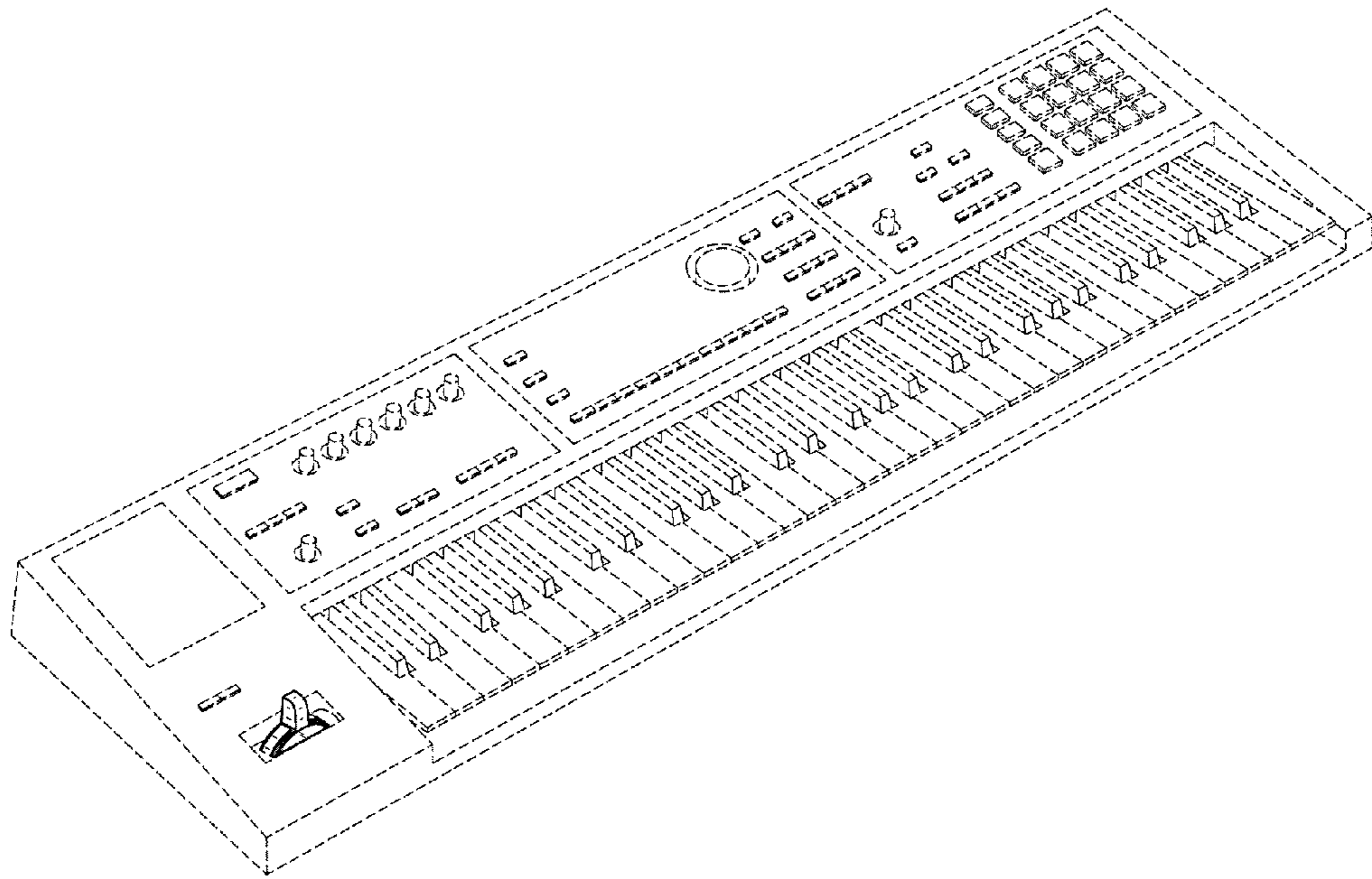

FIG. 16