



US00D716203S

(12) **United States Design Patent**
Nakai

(10) **Patent No.:** **US D716,203 S**
(45) **Date of Patent:** **** Oct. 28, 2014**

(54) **STEERING WHEEL FOR AUTOMOBILE**

(71) Applicant: **Honda Motor Co., Ltd**, Tokyo (JP)

(72) Inventor: **Yuta Nakai**, Wako (JP)

(73) Assignee: **Honda Motor Co., Ltd.**, Tokyo (JP)

(**) Term: **14 Years**

(21) Appl. No.: **29/459,045**

(22) Filed: **Jun. 25, 2013**

(30) **Foreign Application Priority Data**

Dec. 28, 2012 (JP) 2012-032048

(51) **LOC (10) Cl.** **12-16**

(52) **U.S. Cl.**
USPC **D12/176**

(58) **Field of Classification Search**
USPC D12/175, 176; 74/552, 558, 558.5
See application file for complete search history.

(56) **References Cited**

U.S. PATENT DOCUMENTS

D620,853 S * 8/2010 Wiedeman et al. D12/176
D630,983 S * 1/2011 Frank et al. D12/176

D651,542 S * 1/2012 Nagasawa et al. D12/176
D653,180 S * 1/2012 Tanaka et al. D12/176
D684,511 S * 6/2013 Koyama D12/176
D703,594 S * 4/2014 Kim et al. D12/176
D704,108 S * 5/2014 Frank et al. D12/176

* cited by examiner

Primary Examiner — Melody Brown

(74) *Attorney, Agent, or Firm* — Westerman, Hattori,
Daniels & Adrian, LLP

(57) **CLAIM**

The ornamental design for a steering wheel for automobile, as shown and described.

DESCRIPTION

FIG. 1 is a perspective view from the left side of a steering wheel for automobile.

FIG. 2 is a front elevation view thereof.

FIG. 3 is a right side elevational view thereof, the left side being a mirror image of the right side shown;

FIG. 4 is a top plan view thereof; and,

FIG. 5 is a bottom plan view thereof.

The portions of the steering wheel shown in broken lines are for the purpose of showing environmental structure only and form no part of the claimed design.

1 Claim, 5 Drawing Sheets

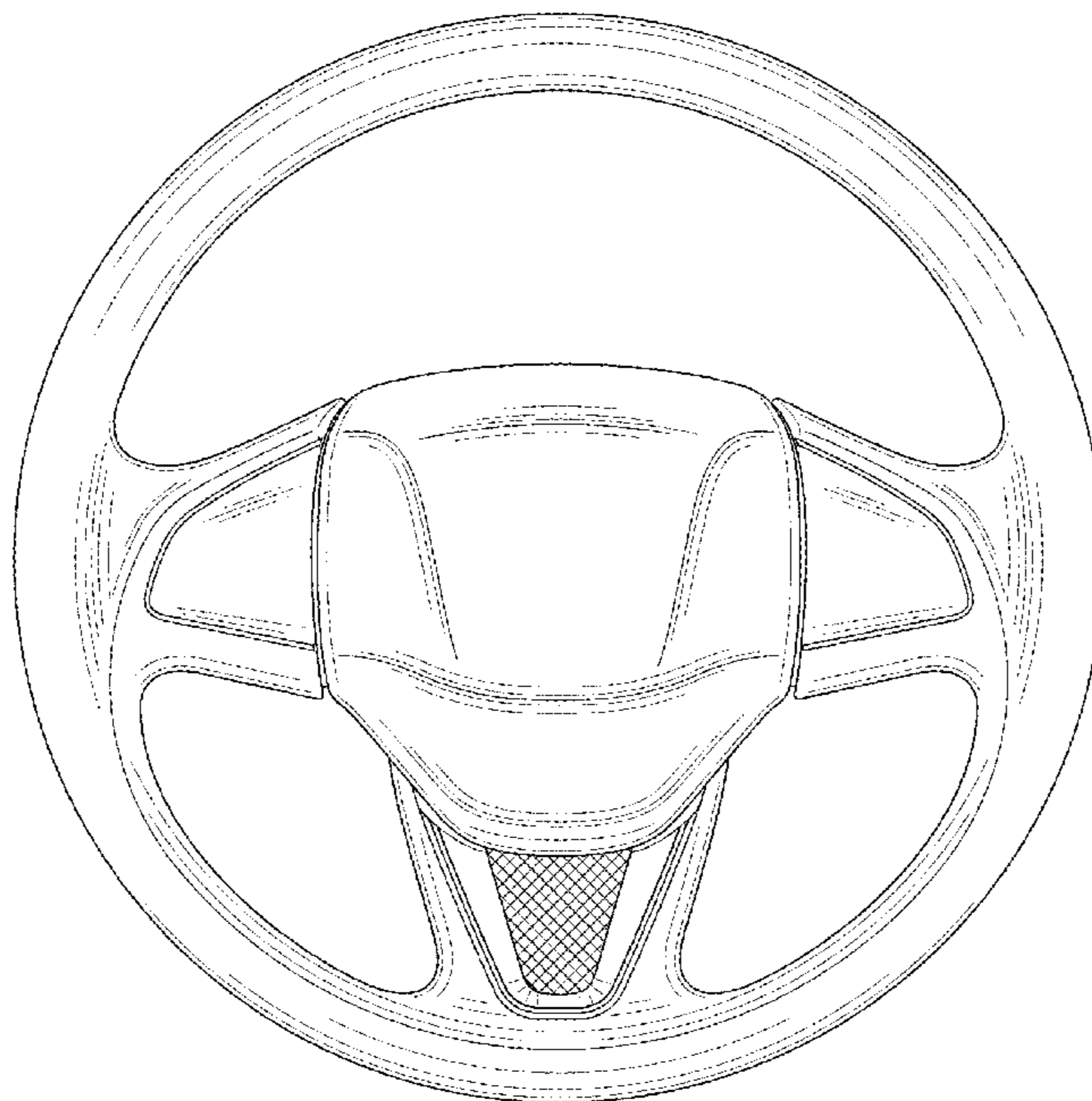

FIG. 1

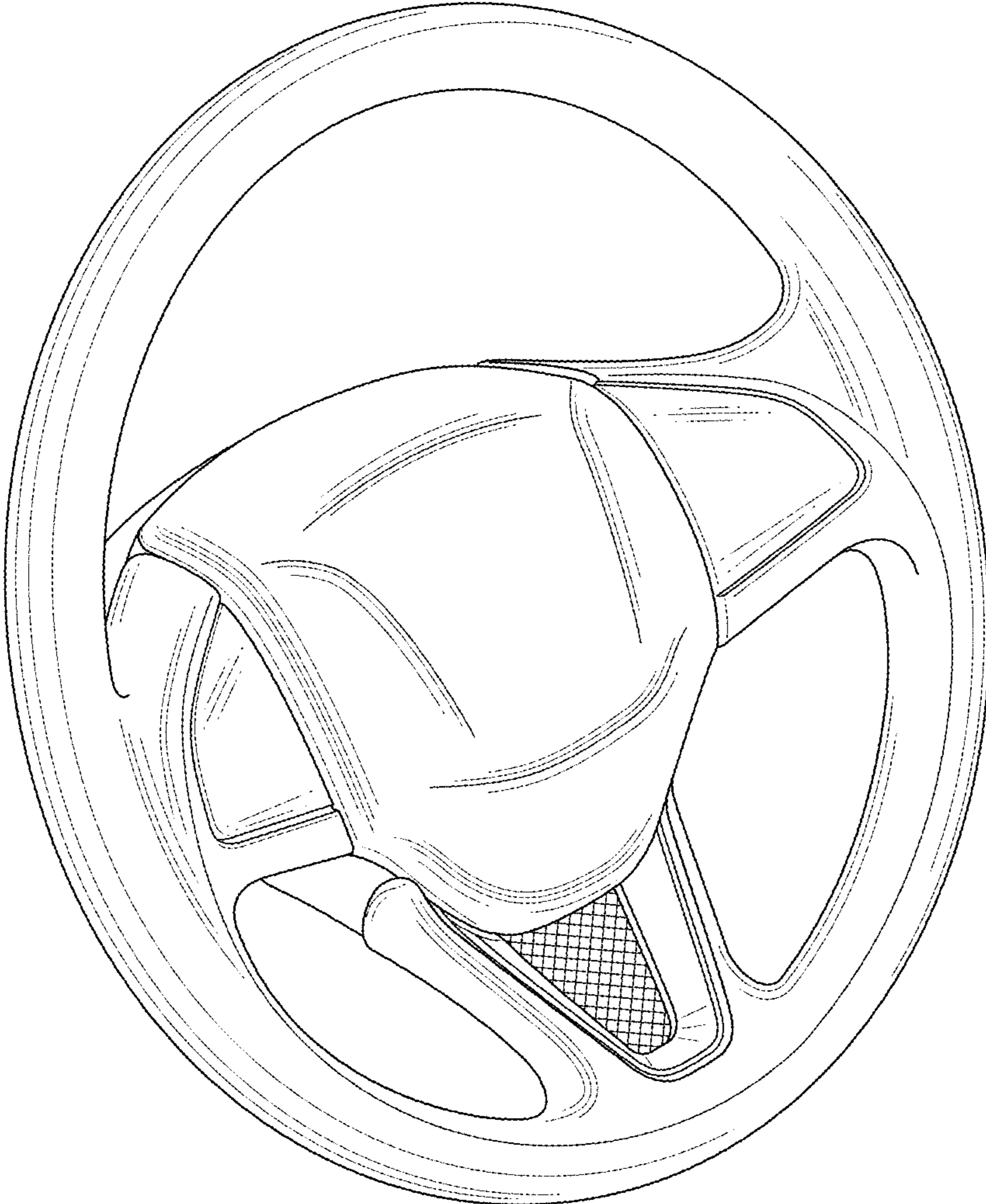

FIG. 2

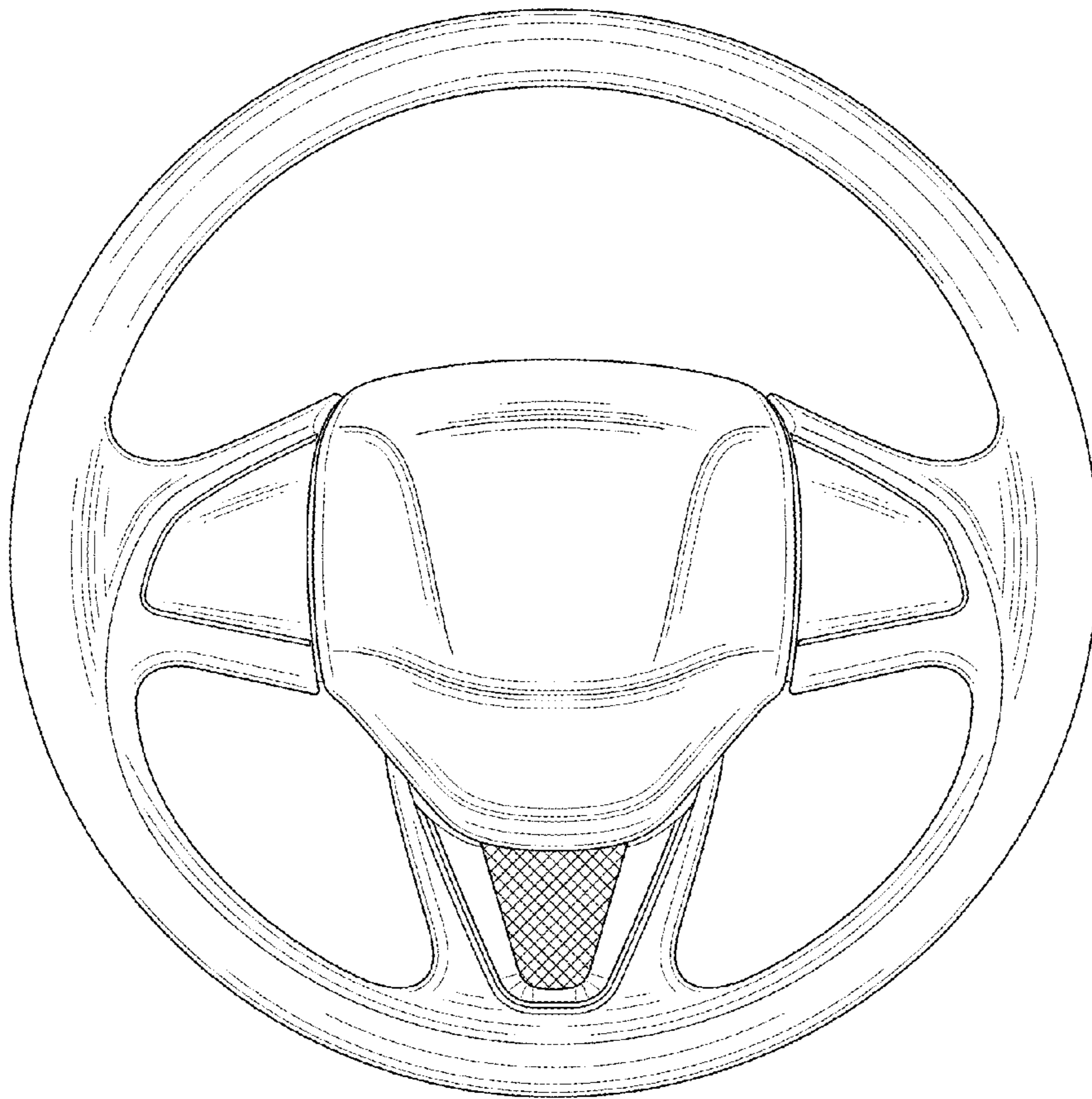

FIG. 3

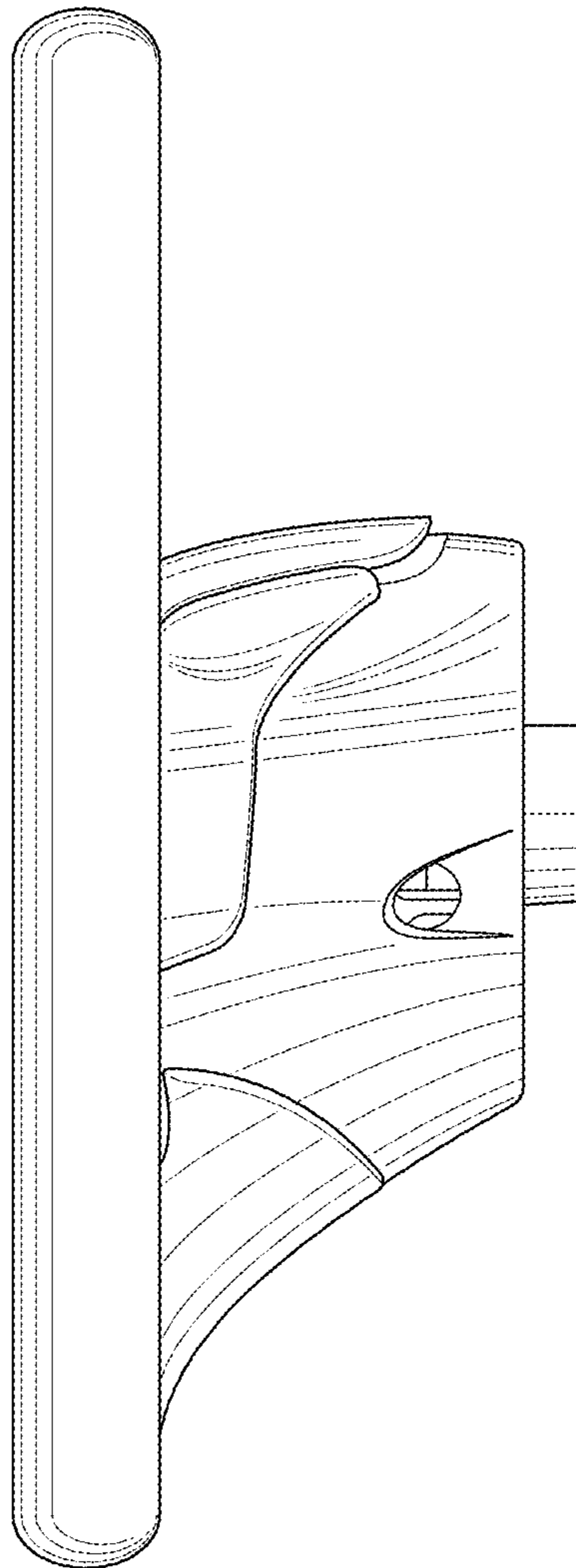

FIG. 4

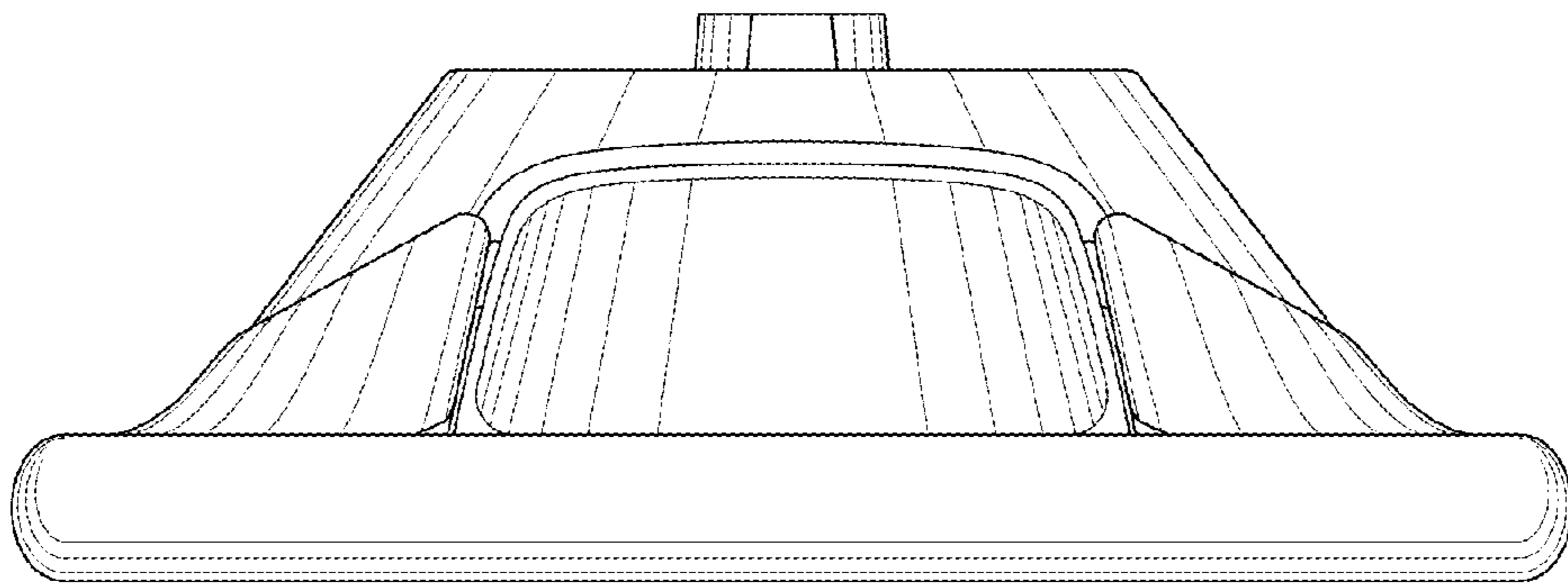
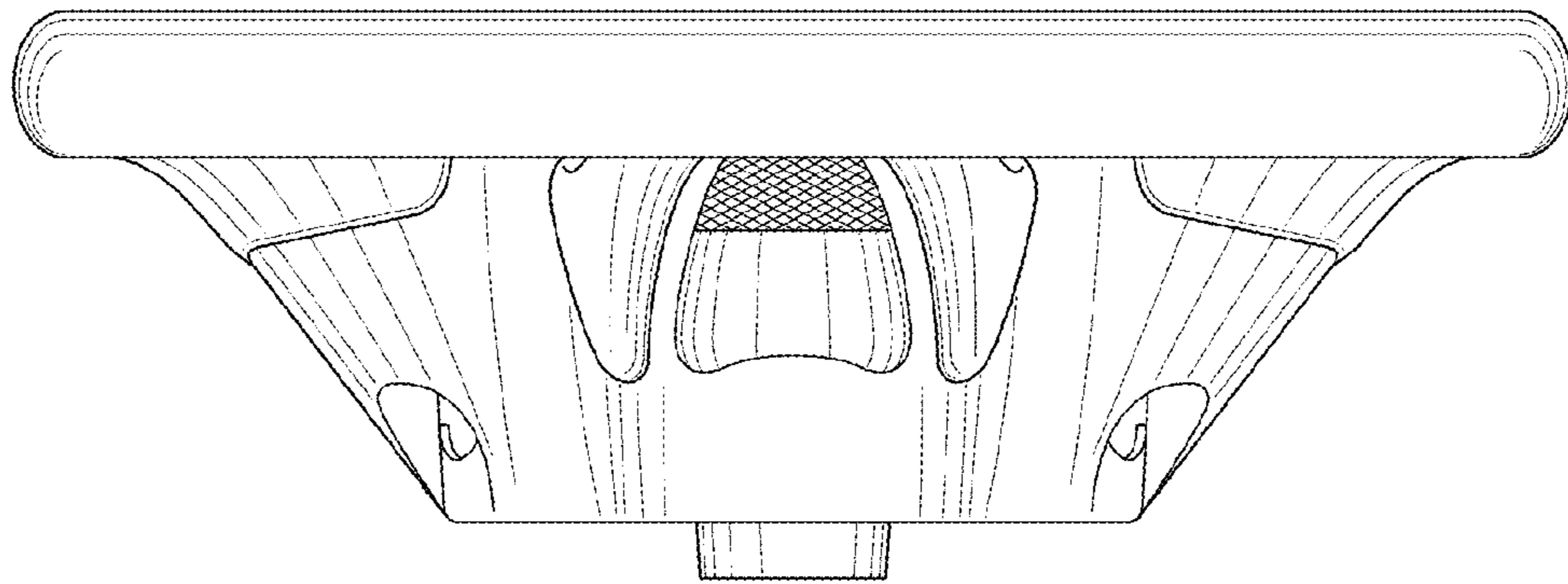

FIG. 5



UNITED STATES PATENT AND TRADEMARK OFFICE
CERTIFICATE OF CORRECTION

PATENT NO. : D716,203 S
APPLICATION NO. : 29/459045
DATED : October 28, 2014
INVENTOR(S) : Yuta Nakai

Page 1 of 1

It is certified that error appears in the above-identified patent and that said Letters Patent is hereby corrected as shown below:

**** Title Page ****

In the Description, please delete the following paragraph:

“The portions of the steering wheel shown in broken lines are for the purpose of showing environmental structure only and form no part of the claimed design.”

Signed and Sealed this
Eighth Day of September, 2015



Michelle K. Lee
Director of the United States Patent and Trademark Office