



US00D716158S

(12) **United States Design Patent**
Baumgartner et al.

(10) **Patent No.:** **US D716,158 S**

(45) **Date of Patent:** **** Oct. 28, 2014**

(54) **ROOM UNIT/HMI**

USPC D10/49-50; D13/162
See application file for complete search history.

(71) Applicants: **Klaus Baumgartner**, Sindelfingen (DE);
Lars Gerold, Stuttgart (DE); **Dominik Riesen**, Lucerne (CH)

(56) **References Cited**

U.S. PATENT DOCUMENTS

(72) Inventors: **Klaus Baumgartner**, Sindelfingen (DE);
Lars Gerold, Stuttgart (DE); **Dominik Riesen**, Lucerne (CH)

D539,676 S * 4/2007 Hedderich et al. D10/49
D595,161 S * 6/2009 Fisher et al. D10/50
D610,475 S * 2/2010 Beers et al. D10/50
D664,453 S * 7/2012 Roddy D10/50

(73) Assignee: **Siemens Aktiengesellschaft**, Munich (DE)

* cited by examiner

(**) Term: **14 Years**

Primary Examiner — Antoine D Davis

(21) Appl. No.: **29/456,051**

(74) *Attorney, Agent, or Firm* — Staas & Halsey LLP

(22) Filed: **May 28, 2013**

(57) **CLAIM**

The ornamental design for a room unit/HMI, as shown and described.

(30) **Foreign Application Priority Data**

DESCRIPTION

Nov. 28, 2012 (EM) 002144022
Jan. 24, 2013 (EM) 002172171

FIG. 1 is a front view of an operation device of our new design;
FIG. 2 is a rear view thereof;
FIG. 3 is a top view thereof;
FIG. 4 is a bottom view thereof;
FIG. 5 is a right side view thereof;
FIG. 6 is a left side view thereof; and,
FIG. 7 is a perspective view of front, top and right side thereof.

(51) **LOC (10) Cl.** **10-04**

(52) **U.S. Cl.**
USPC **D10/50**

The broken line showing of structural features is included for the purpose of illustrating non-claimed subject matter and forms no part of the claimed design.

(58) **Field of Classification Search**
CPC F23N 5/20; F23N 5/122; F23N 5/203;
F23N 2025/12; F23N 2041/02; F24F 11/00;
F24F 11/0012; F24F 2011/0071; F24F
2011/0072; F24F 2011/0091; G05B 19/042;
G05B 2219/24048; G05B 2219/24102; G05D
23/01; G05D 23/12

1 Claim, 7 Drawing Sheets

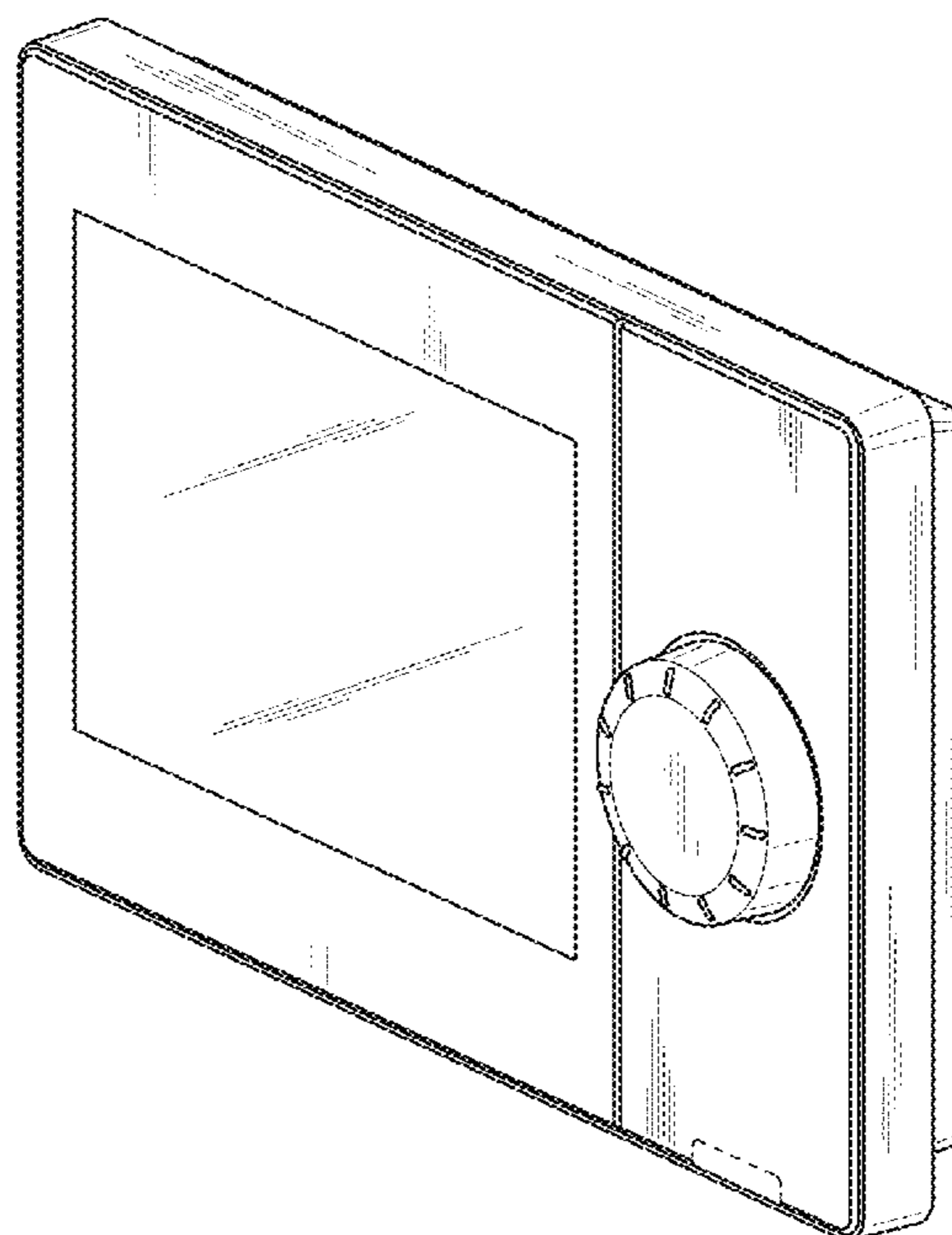

FIG. 1

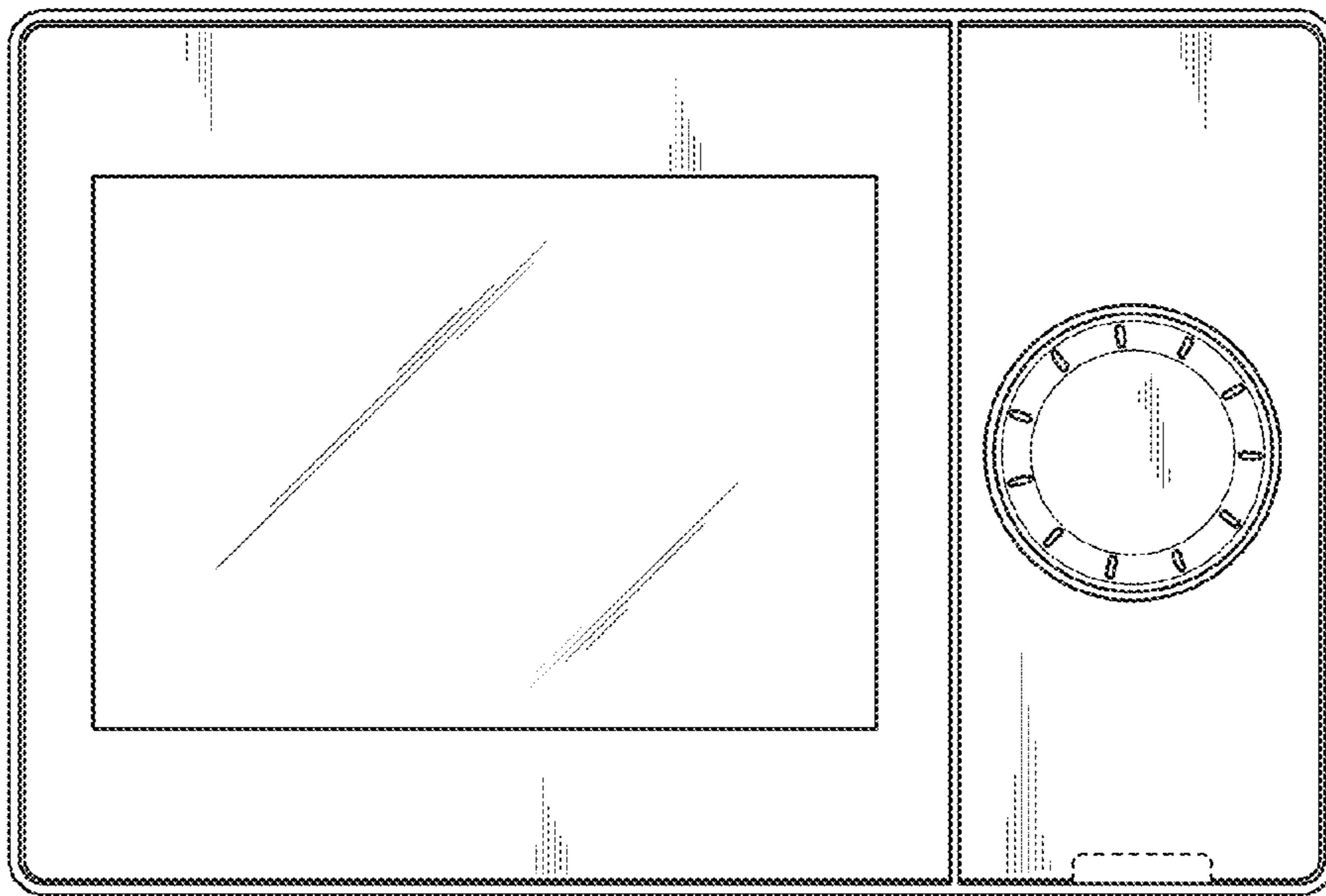

FIG. 2

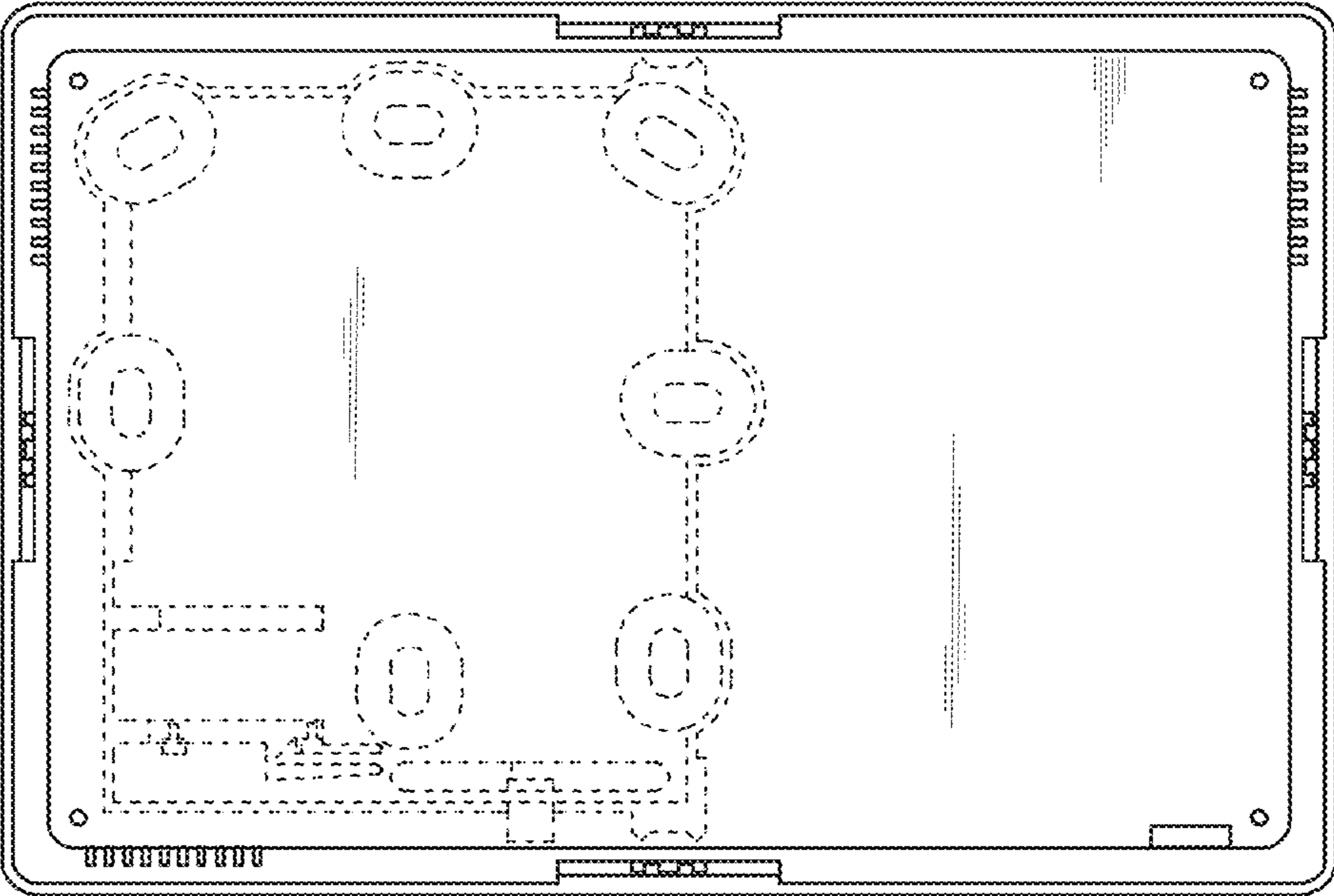

FIG. 3

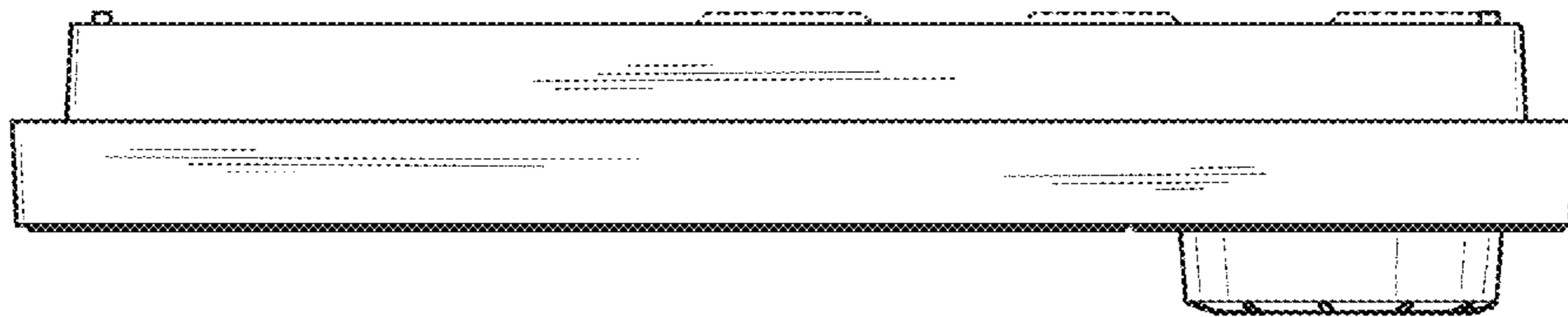

FIG. 4



FIG. 5

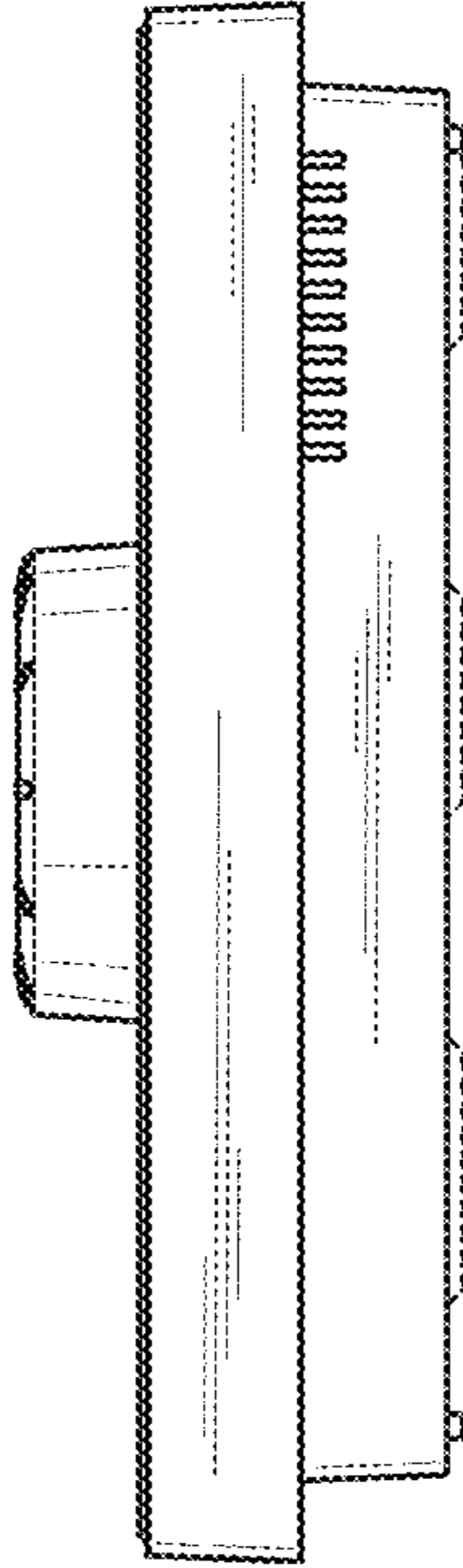

FIG. 6

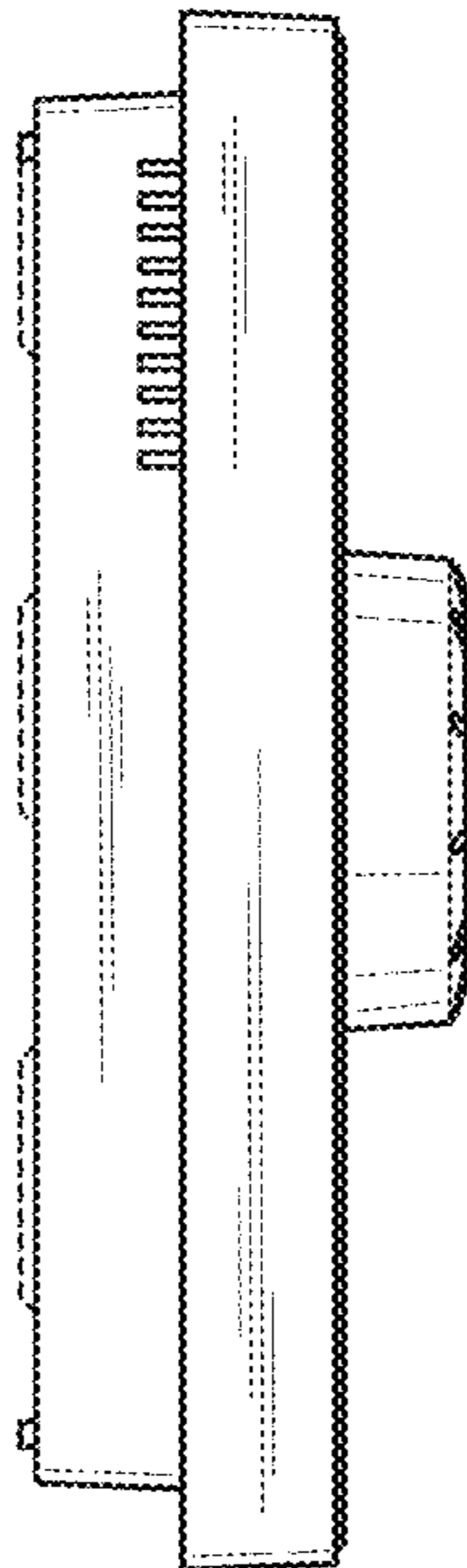

FIG. 7

