



US00D715978S

(12) **United States Design Patent**  
**Loeb**

(10) **Patent No.:** **US D715,978 S**  
(45) **Date of Patent:** **\*\* Oct. 21, 2014**

(54) **VEHICLE HEADLIGHT**  
(71) Applicant: **GM Global Technology Operations LLC**, Detroit, MI (US)  
(72) Inventor: **Niels Loeb**, Wiesbaden (DE)  
(73) Assignee: **GM Global Technology Operations LLC**, Detroit, MI (US)  
(\*\*) Term: **14 Years**

*Primary Examiner* — Marcus Jackson  
(74) *Attorney, Agent, or Firm* — Reising Ethington P.C.

(21) Appl. No.: **29/457,759**  
(22) Filed: **Jun. 12, 2013**  
(51) **LOC (10) Cl.** ..... **26-06**  
(52) **U.S. Cl.**  
USPC ..... **D26/28**  
(58) **Field of Classification Search**  
USPC ..... D26/28–36; 362/459–468, 475–478,  
362/485–487  
See application file for complete search history.

(57) **CLAIM**  
The ornamental design for a vehicle headlight, as shown and described.

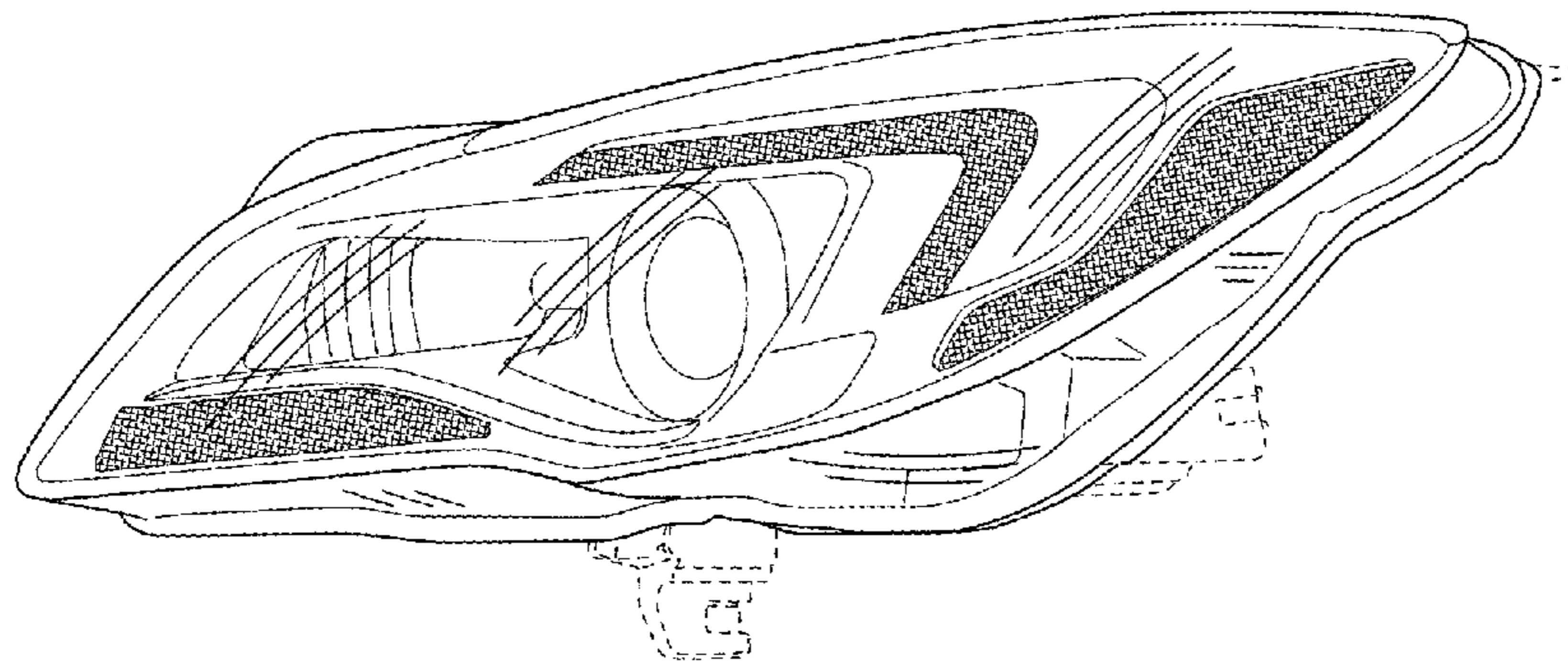
**DESCRIPTION**

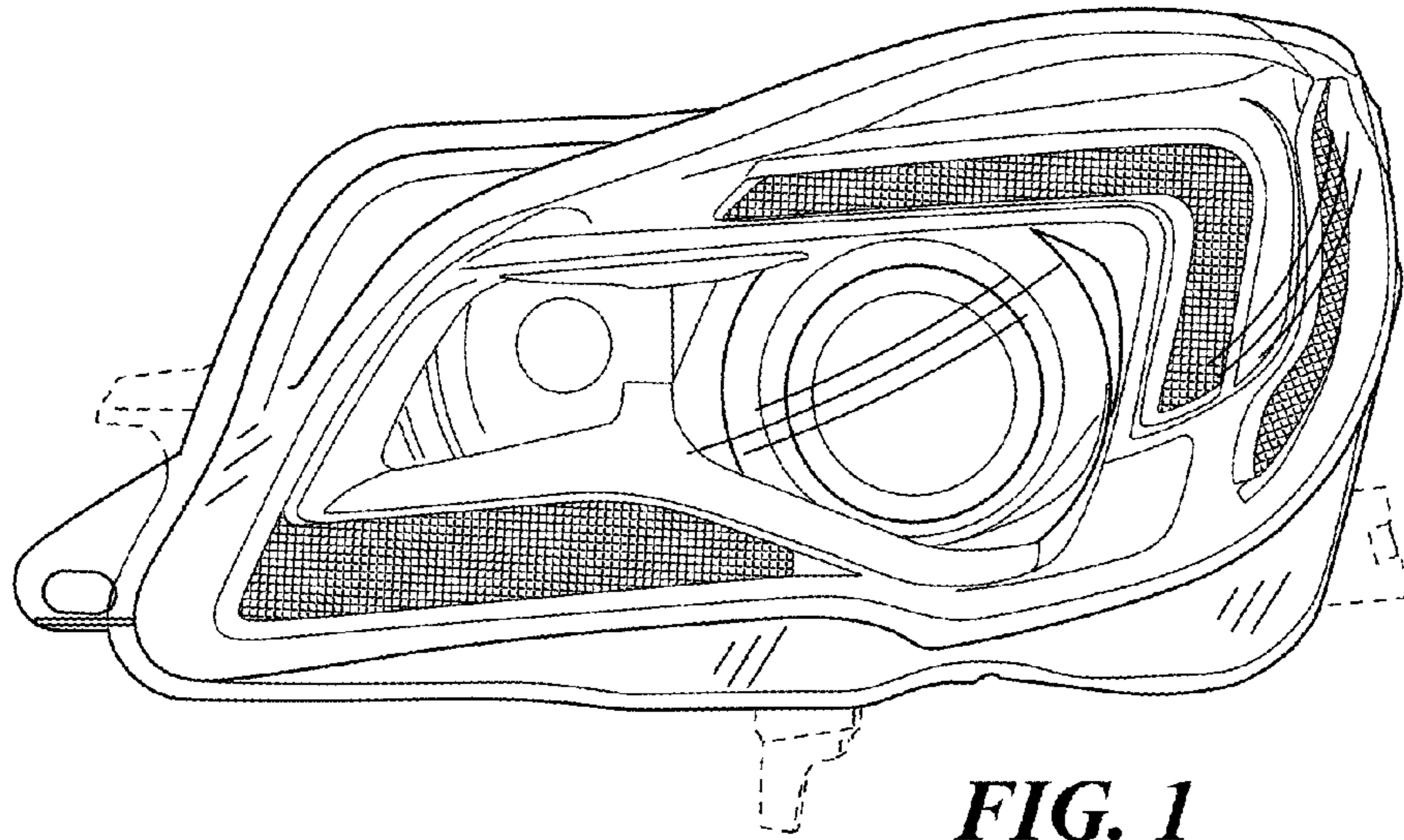
FIG. 1 is a front view of a vehicle headlight;  
FIG. 2 is a side view of the vehicle headlight;  
FIG. 3 is another side view of the vehicle headlight, this view provided at about a forty-five degree rotation relative to FIG. 2;  
FIG. 4 is another side view of the vehicle headlight, this view provided at about a forty-five degree rotation relative to FIG. 3;  
FIG. 5 is another side view of the vehicle headlight, this view provided at about a one-hundred-and-eighty degree rotation relative to FIG. 4;  
FIG. 6 is a rear view of the vehicle headlight, this view provided at about a forty-five degree rotation relative to FIG. 4;  
FIG. 7 is another rear view of the vehicle headlight, this view provided at about a forty-five degree rotation relative to FIG. 6;  
FIG. 8 is another rear view of the vehicle headlight, this view provided at about a forty-five degree rotation relative to FIG. 7;  
FIG. 9 is a top view of the vehicle headlight; and,  
FIG. 10 is a bottom view of the vehicle headlight.  
In the drawings, the portions shown by broken lines form no part of the claimed design.

(56) **References Cited**  
U.S. PATENT DOCUMENTS  
D550,380 S \* 9/2007 Lin ..... D26/28  
D560,291 S \* 1/2008 Koyama ..... D26/28  
D560,832 S \* 1/2008 Hsu ..... D26/28  
D561,358 S \* 2/2008 Tachibana ..... D26/28  
D561,359 S \* 2/2008 Hsu ..... D26/28  
D563,576 S \* 3/2008 Hanaoka ..... D26/28  
D569,533 S \* 5/2008 Hsu ..... D26/28  
D570,007 S \* 5/2008 Hsu ..... D26/28  
D593,232 S \* 5/2009 Koman et al. .... D26/28  
D683,057 S 5/2013 Aikawa et al.  
D683,487 S 5/2013 Scheinhutte et al.  
D683,488 S 5/2013 Scheinhutte et al.  
D683,875 S 6/2013 Platto et al.

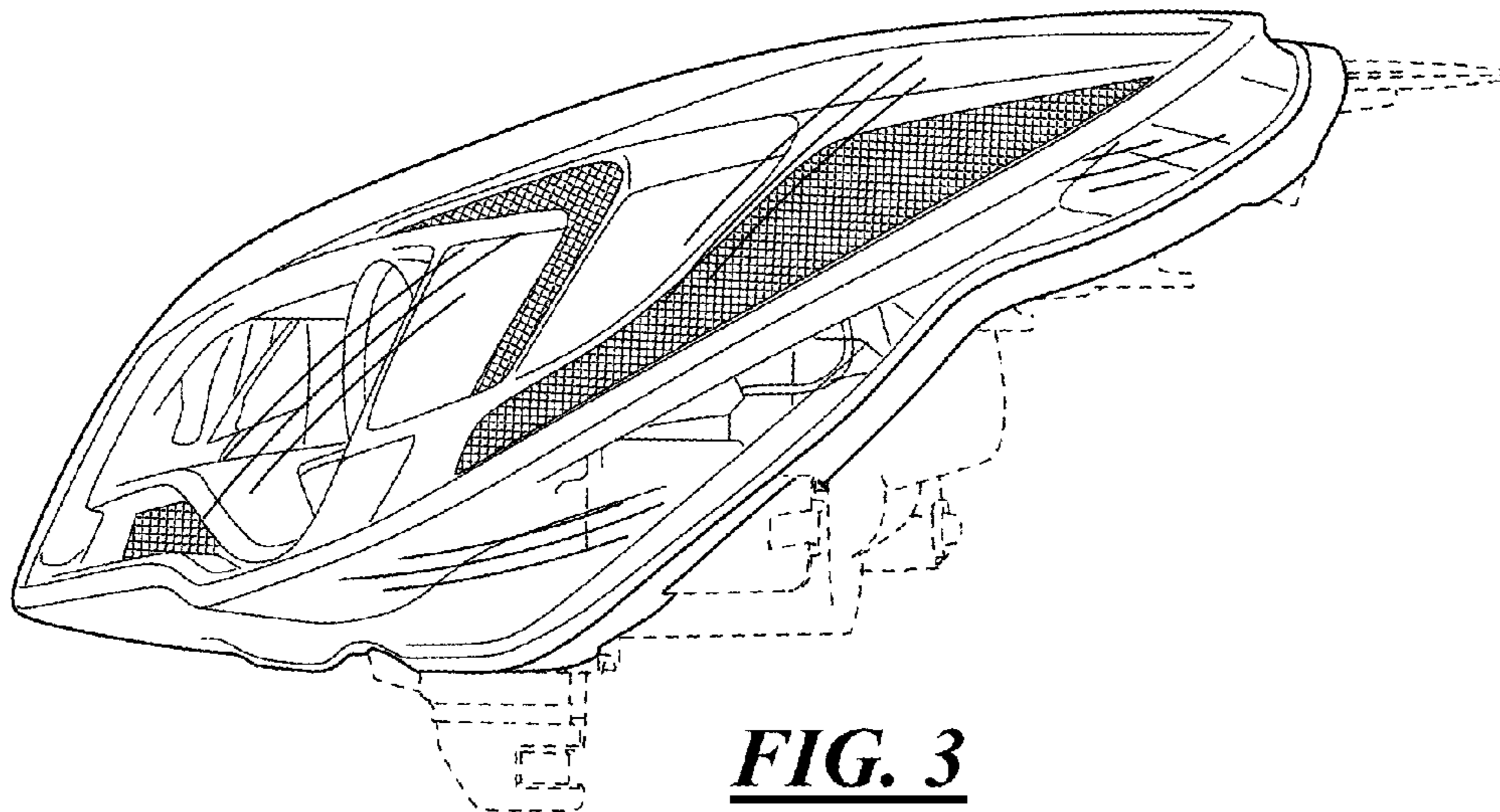
\* cited by examiner

**1 Claim, 5 Drawing Sheets**

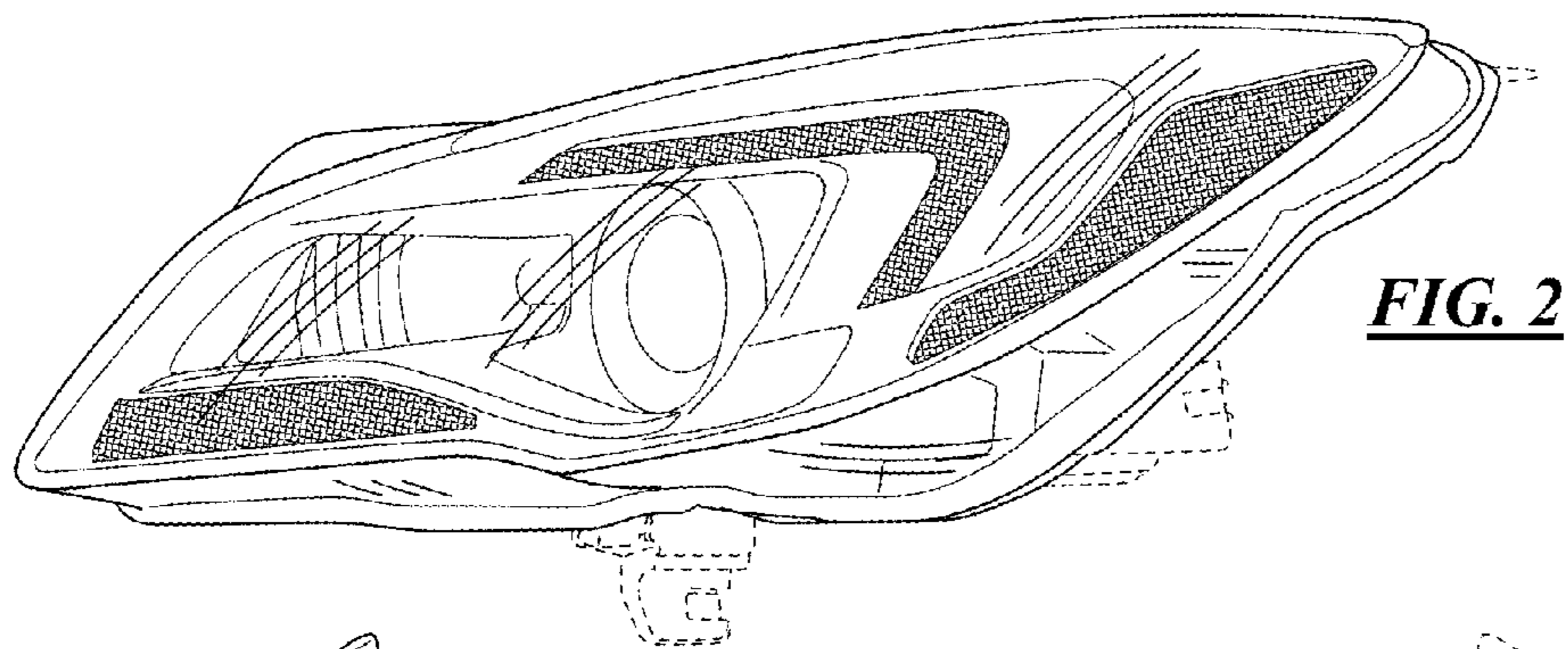




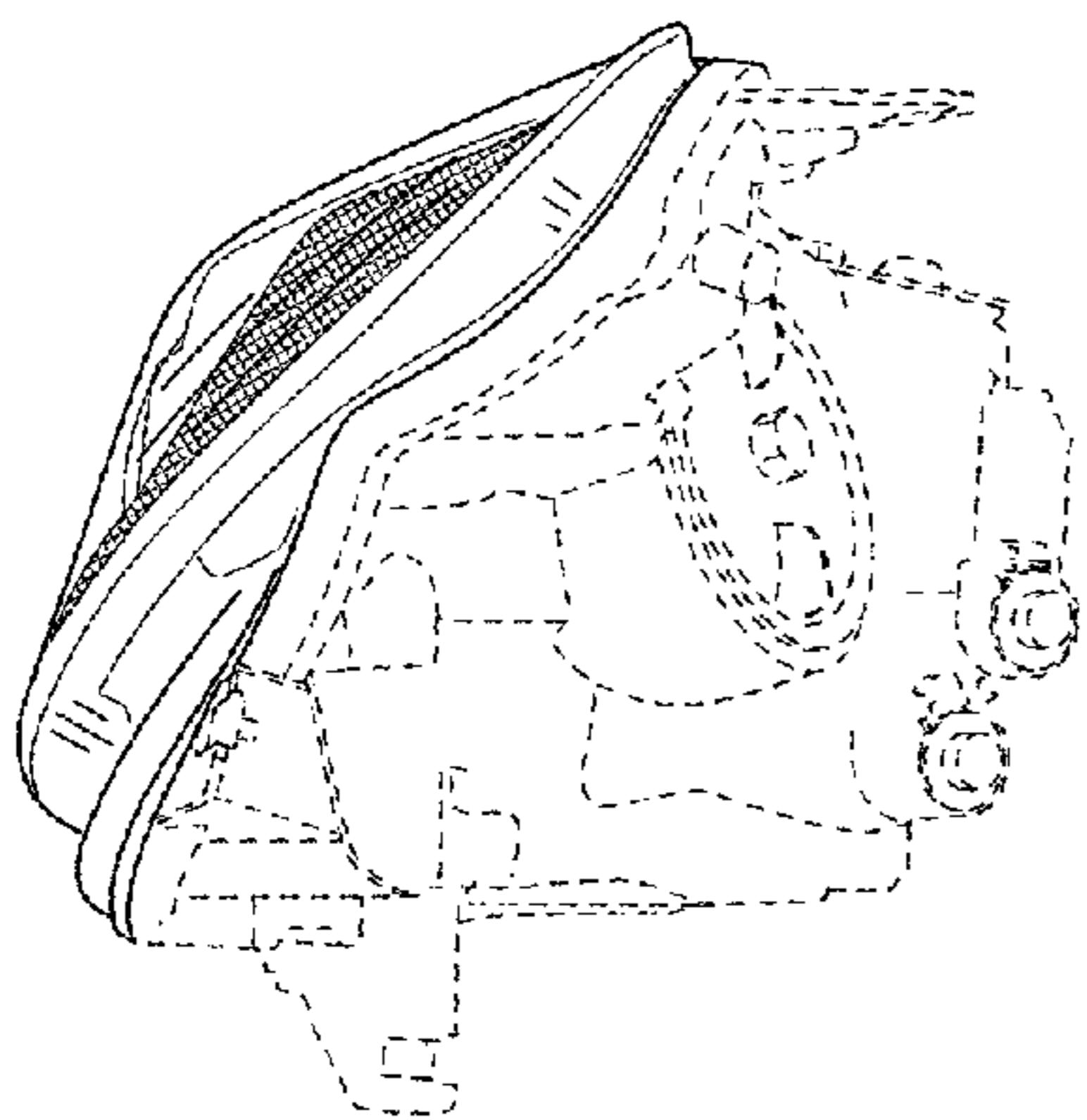
**FIG. 1**



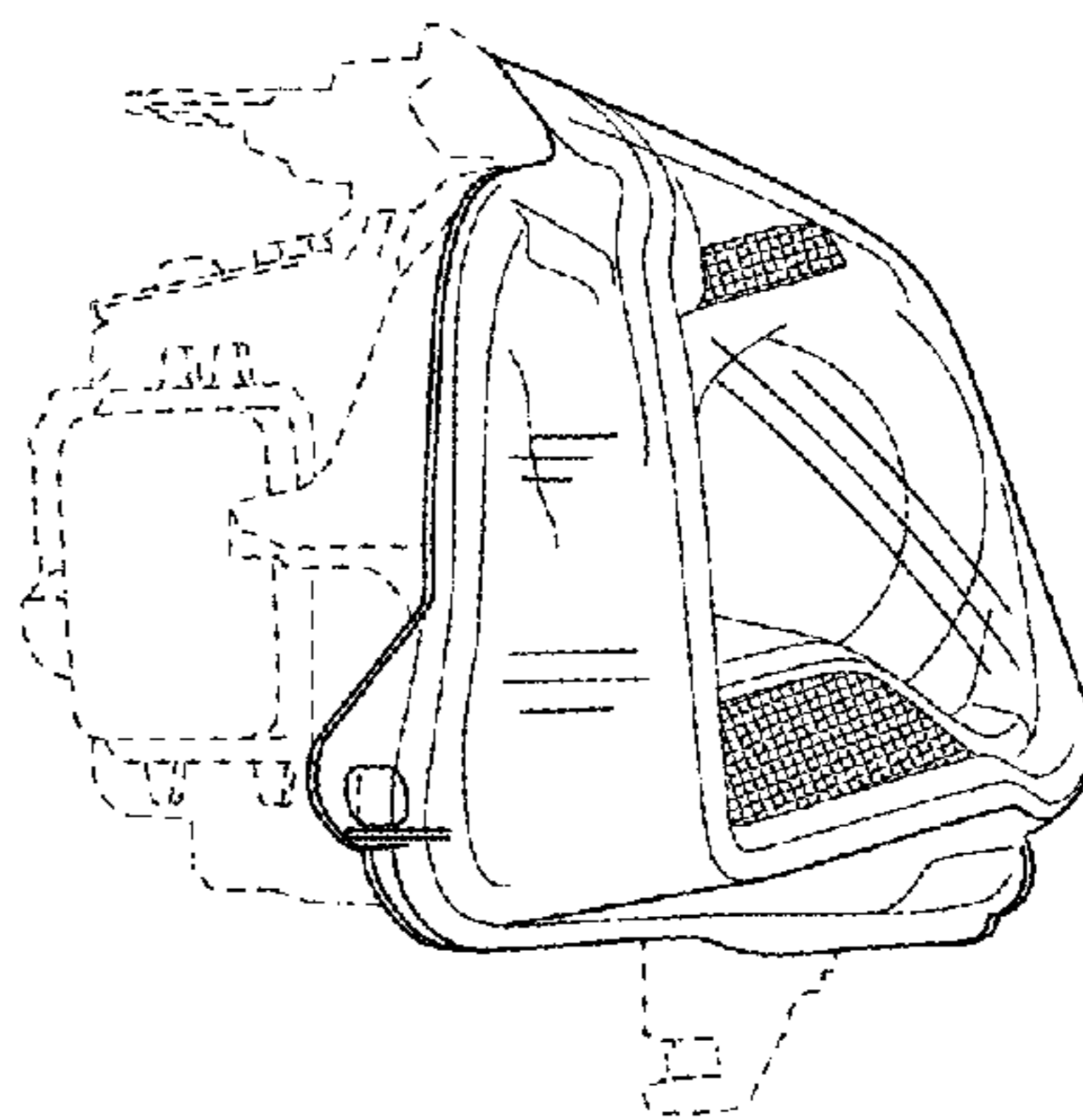
**FIG. 3**



**FIG. 2**

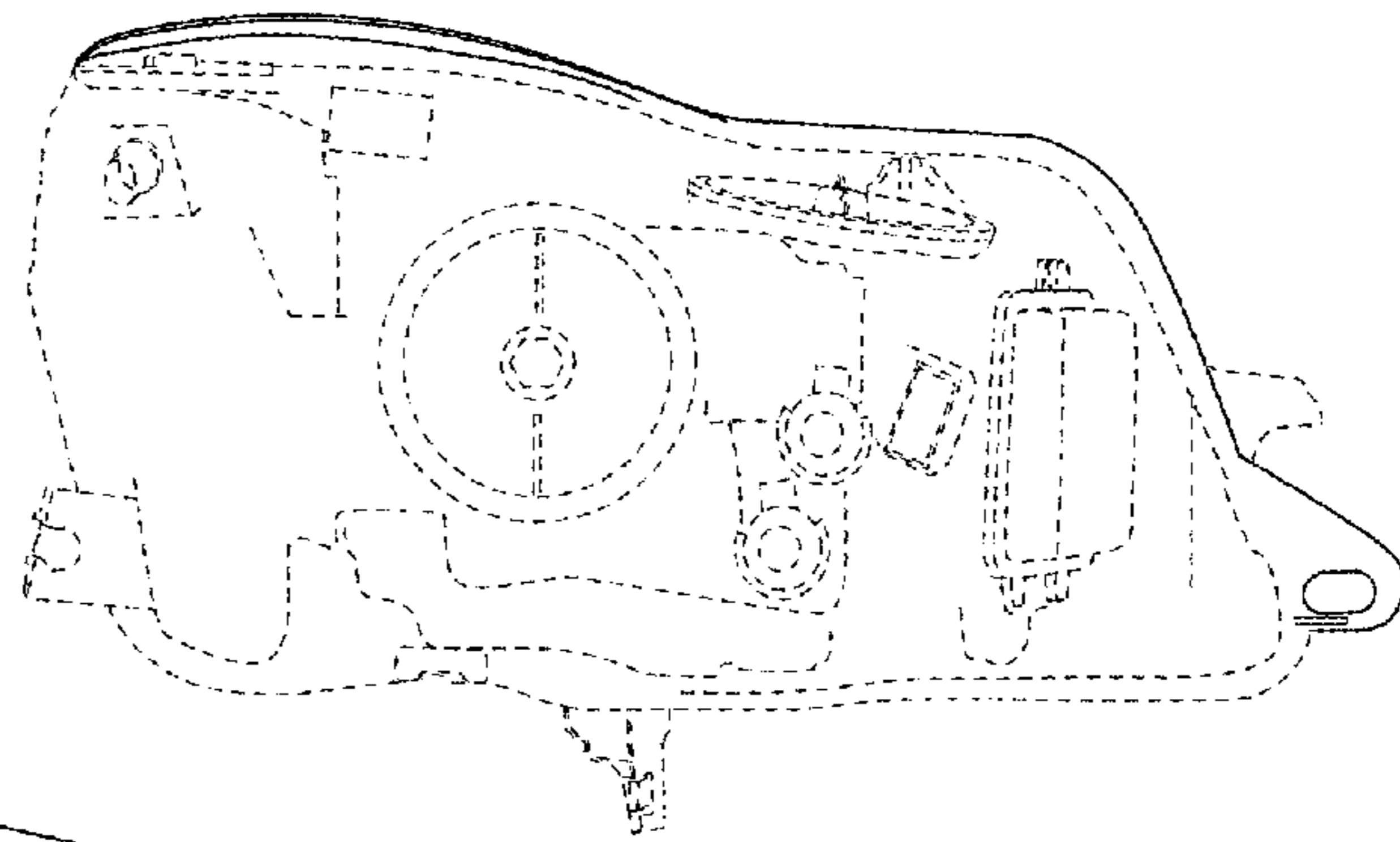


**FIG. 4**

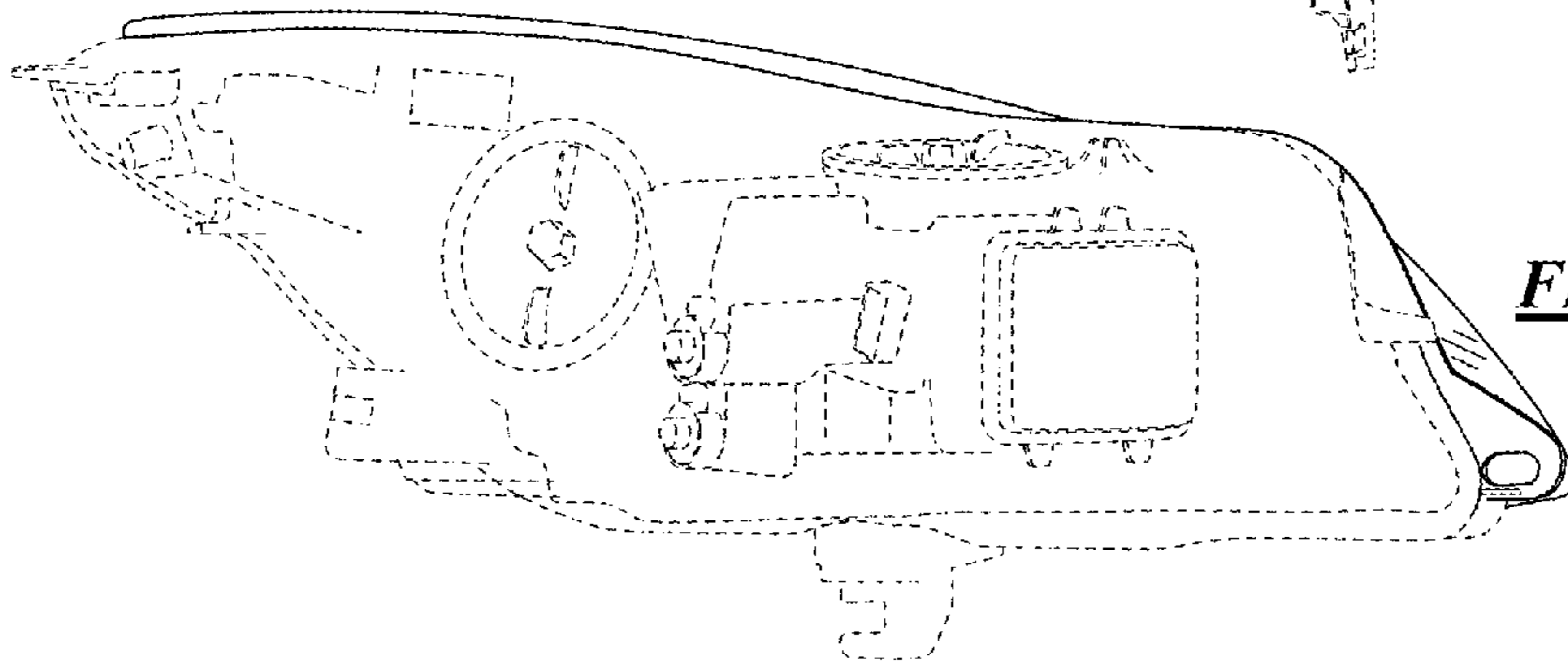


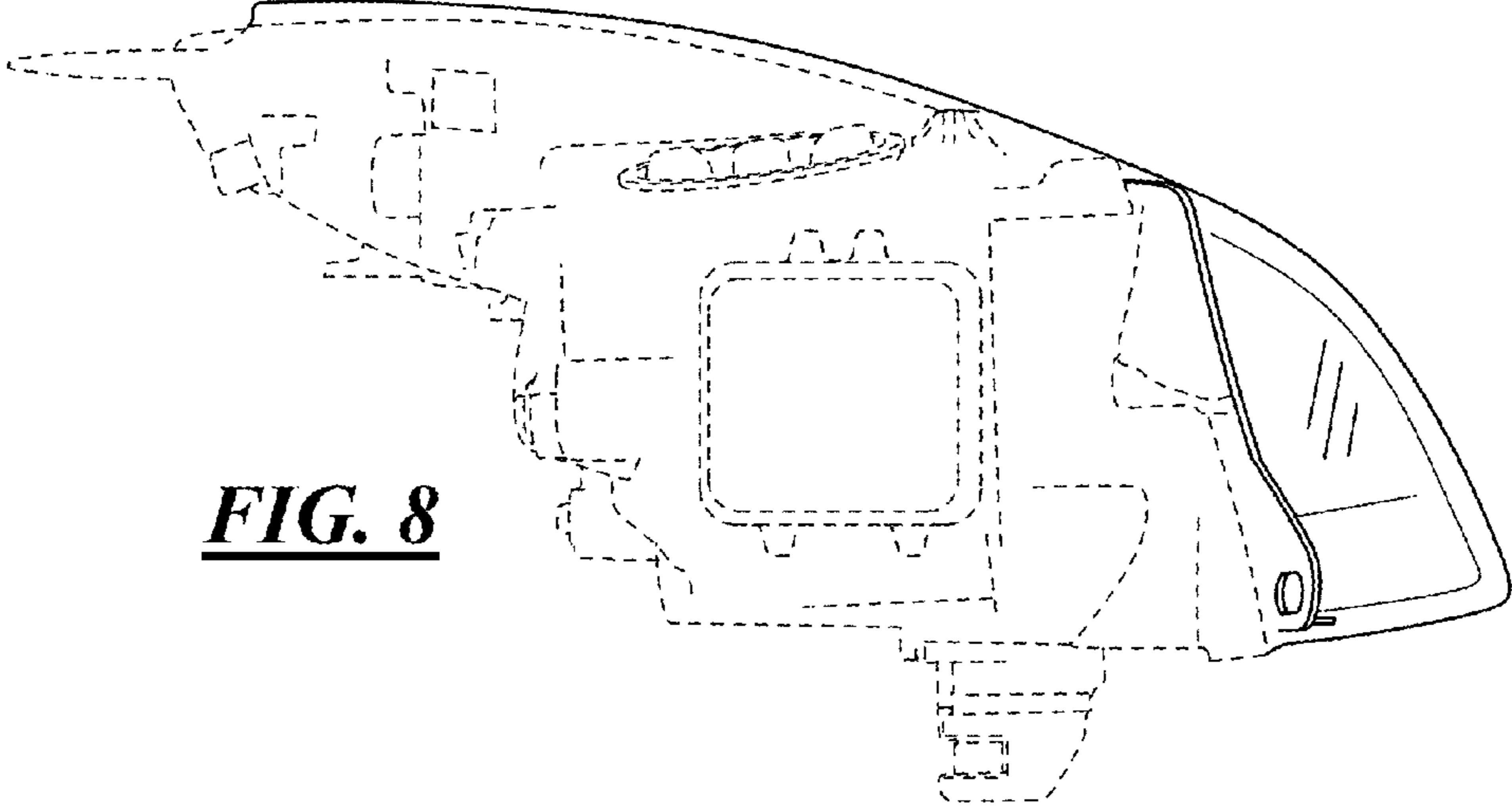
**FIG. 5**

**FIG. 6**

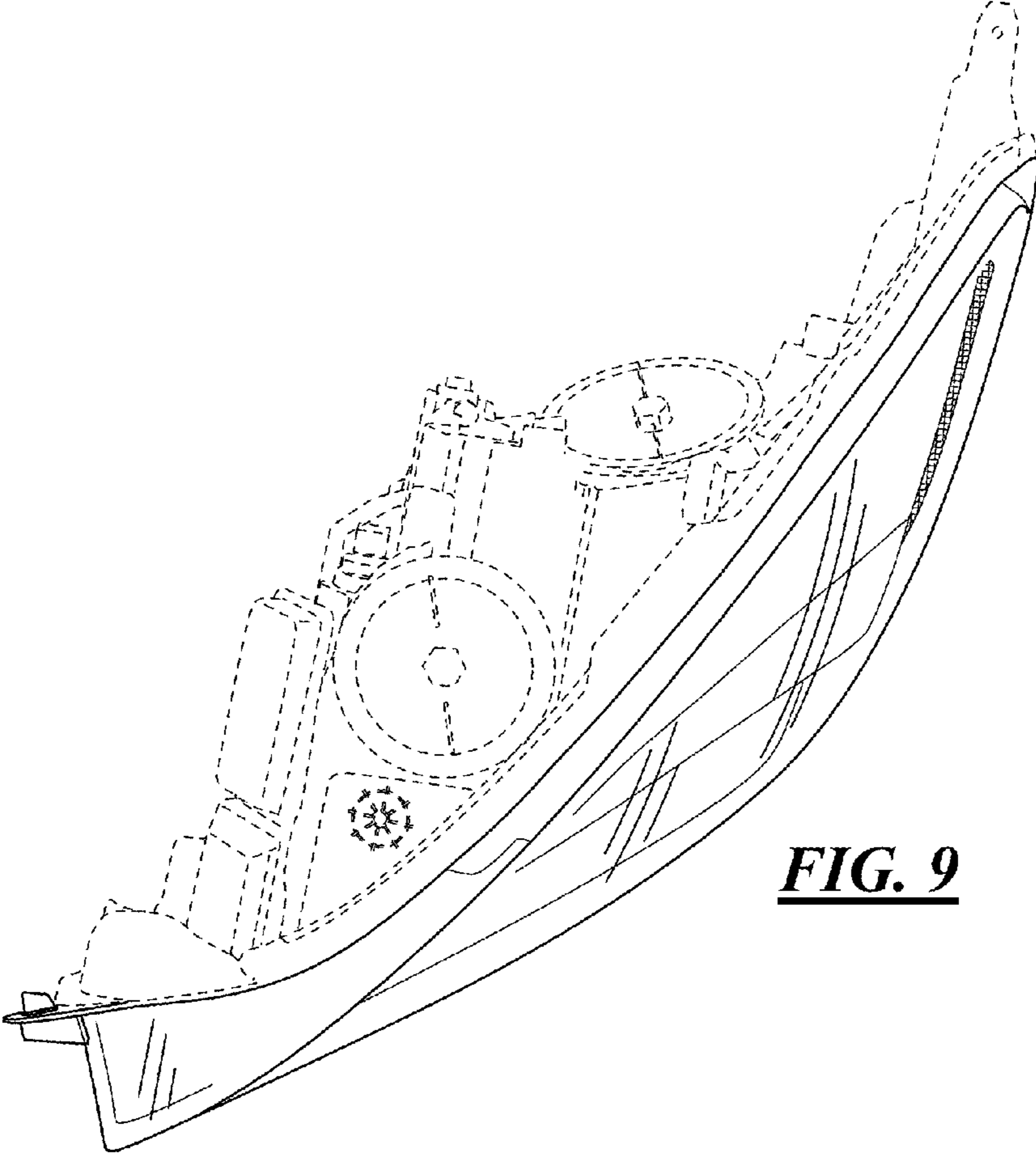


**FIG. 7**

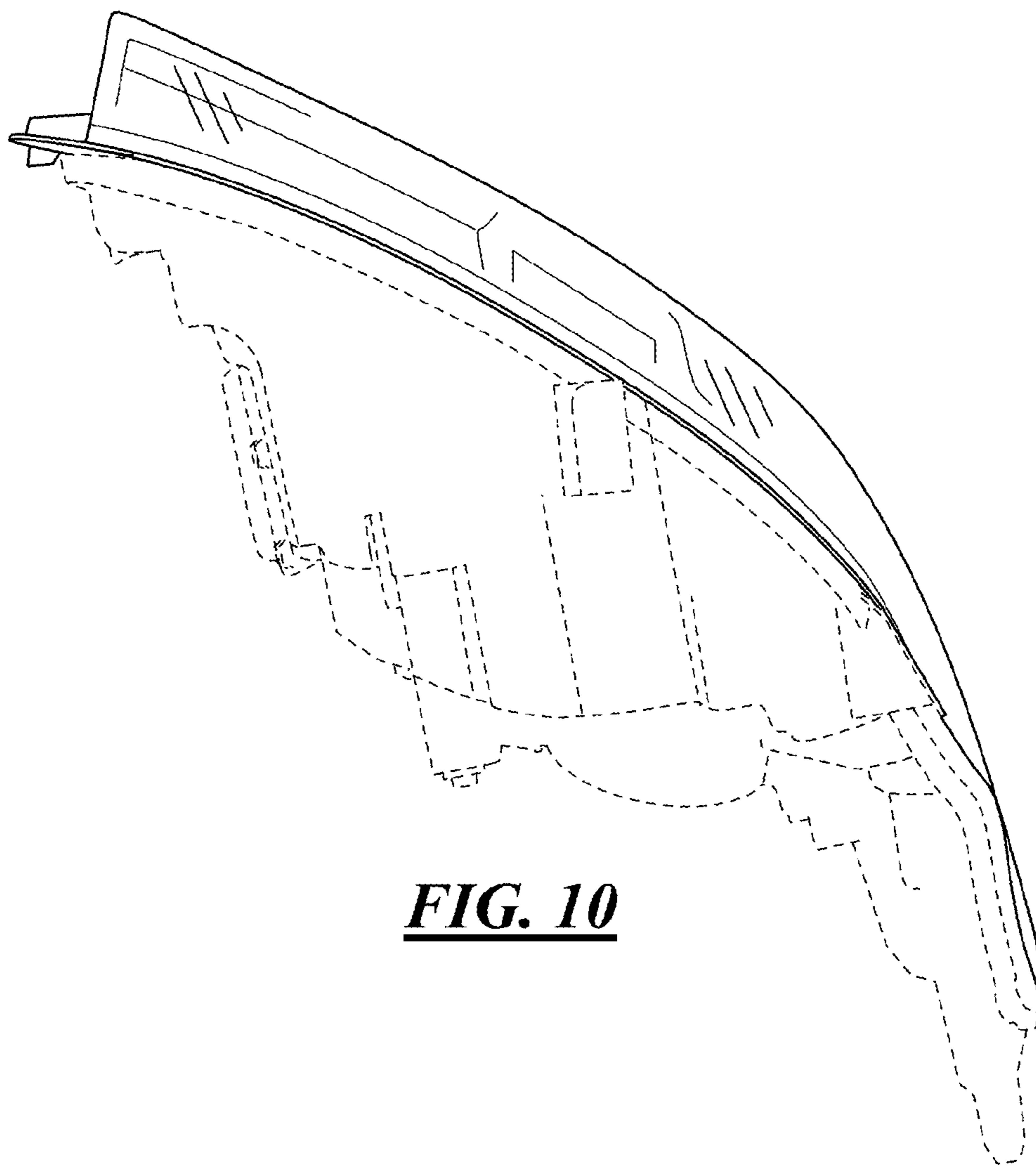




**FIG. 8**



**FIG. 9**



**FIG. 10**