



US00D715914S

(12) **United States Design Patent**
Schouten

(10) **Patent No.:** **US D715,914 S**
(45) **Date of Patent:** **** Oct. 21, 2014**

(54) **AIR FRESHENER**

(71) Applicant: **Hopkins Manufacturing Corporation,**
Emporia, KS (US)

(72) Inventor: **Pieter Schouten,** Berkeley, CA (US)

(73) Assignee: **Hopkins Manufacturing Corporation,**
Emporia, KS (US)

(**) Term: **14 Years**

(21) Appl. No.: **29/485,276**

(22) Filed: **Mar. 18, 2014**

(51) **LOC (10) Cl.** **28-99**

(52) **U.S. Cl.**
CPC **A61L 9/03** (2013.01)
USPC **D23/368**

(58) **Field of Classification Search**
CPC A61L 9/00; A61L 9/02; A61L 9/03;
A61L 9/032; A61L 9/035; A61L 9/037;
A61L 9/04; A61L 9/012; A61L 9/022
USPC D23/355-369; D28/5, 6; 261/DIG. 17,
261/DIG. 42, DIG. 65, DIG. 88, DIG. 89;
392/386, 390, 394, 395; 239/34, 44,
239/53, 55, 56, 326
See application file for complete search history.

(56) **References Cited**

U.S. PATENT DOCUMENTS

D437,041 S * 1/2001 Eisenbraun D23/366
D604,825 S * 11/2009 Brandenburg D23/366

7,687,037 B2 * 3/2010 Wheatley et al. 422/124
D619,693 S * 7/2010 Hami et al. D23/366
D619,694 S * 7/2010 Hami et al. D23/366
D620,573 S * 7/2010 Hami et al. D23/366
D625,798 S * 10/2010 Hami et al. D23/367
D640,781 S * 6/2011 Brandenburg D23/366
8,147,761 B2 * 4/2012 Wheatley et al. 422/123
D667,100 S * 9/2012 Hakim D23/366
D684,675 S * 6/2013 Irvin et al. D23/366
D697,603 S * 1/2014 Hakim D23/366
D699,334 S * 2/2014 Alesi et al. D23/366
2003/0202922 A1 * 10/2003 Farmer 422/306
2011/0108632 A1 * 5/2011 Brandenburg et al. 239/34

* cited by examiner

Primary Examiner — Sandra Snapp

(74) *Attorney, Agent, or Firm* — George R. McGuire; Bond
Schoeneck & King, PLLC

(57) **CLAIM**

The ornamental design for an air freshener, as shown and
described.

DESCRIPTION

FIG. 1 is a perspective view of a new and ornamental design
for an air freshener;
FIG. 2 is a front elevation view thereof;
FIG. 3 is a rear elevation view thereof;
FIG. 4 is a first side elevation view thereof;
FIG. 5 is a second side elevation view thereof;
FIG. 6 is a top plan view thereof; and,
FIG. 7 is a bottom plan view thereof.

1 Claim, 7 Drawing Sheets

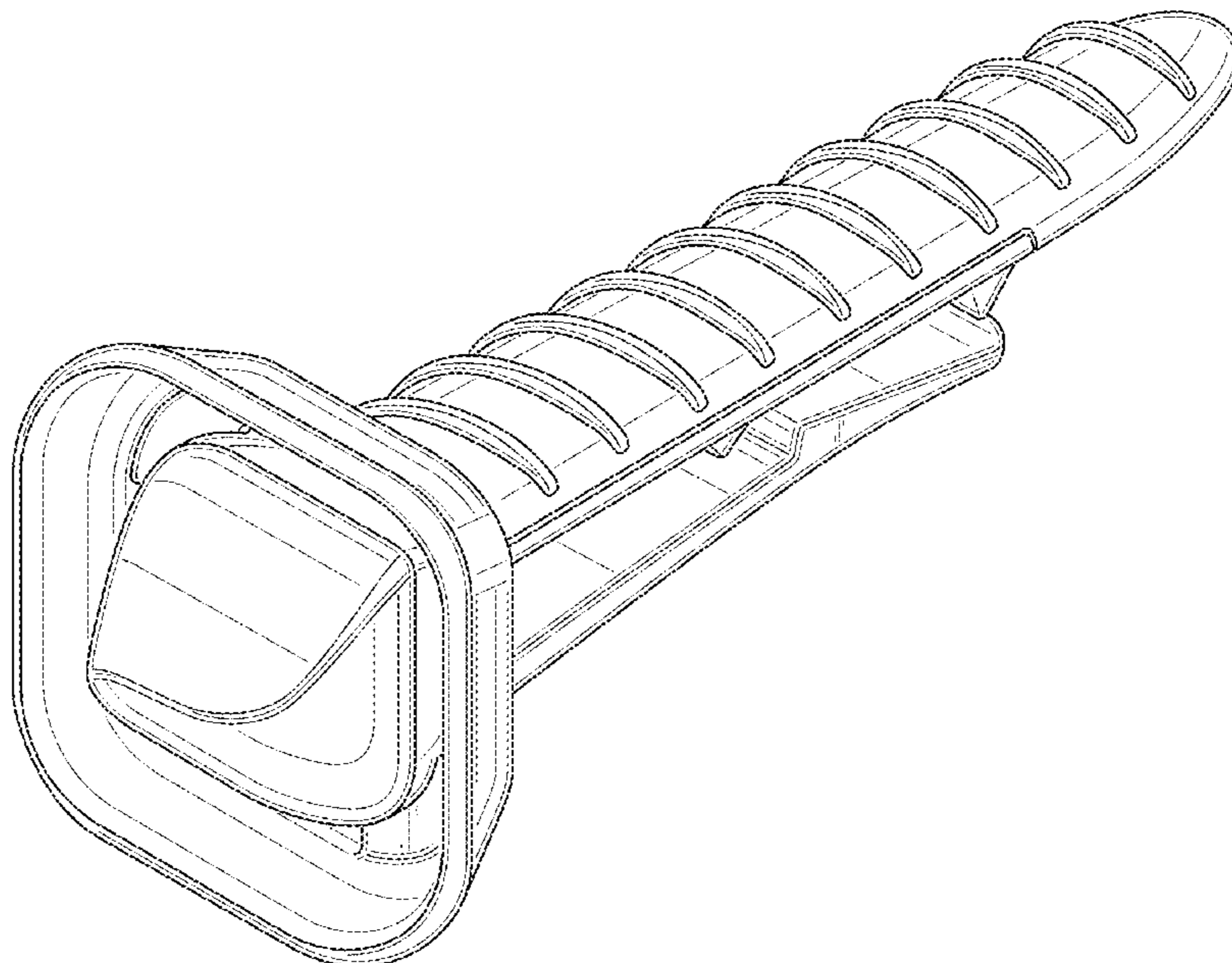

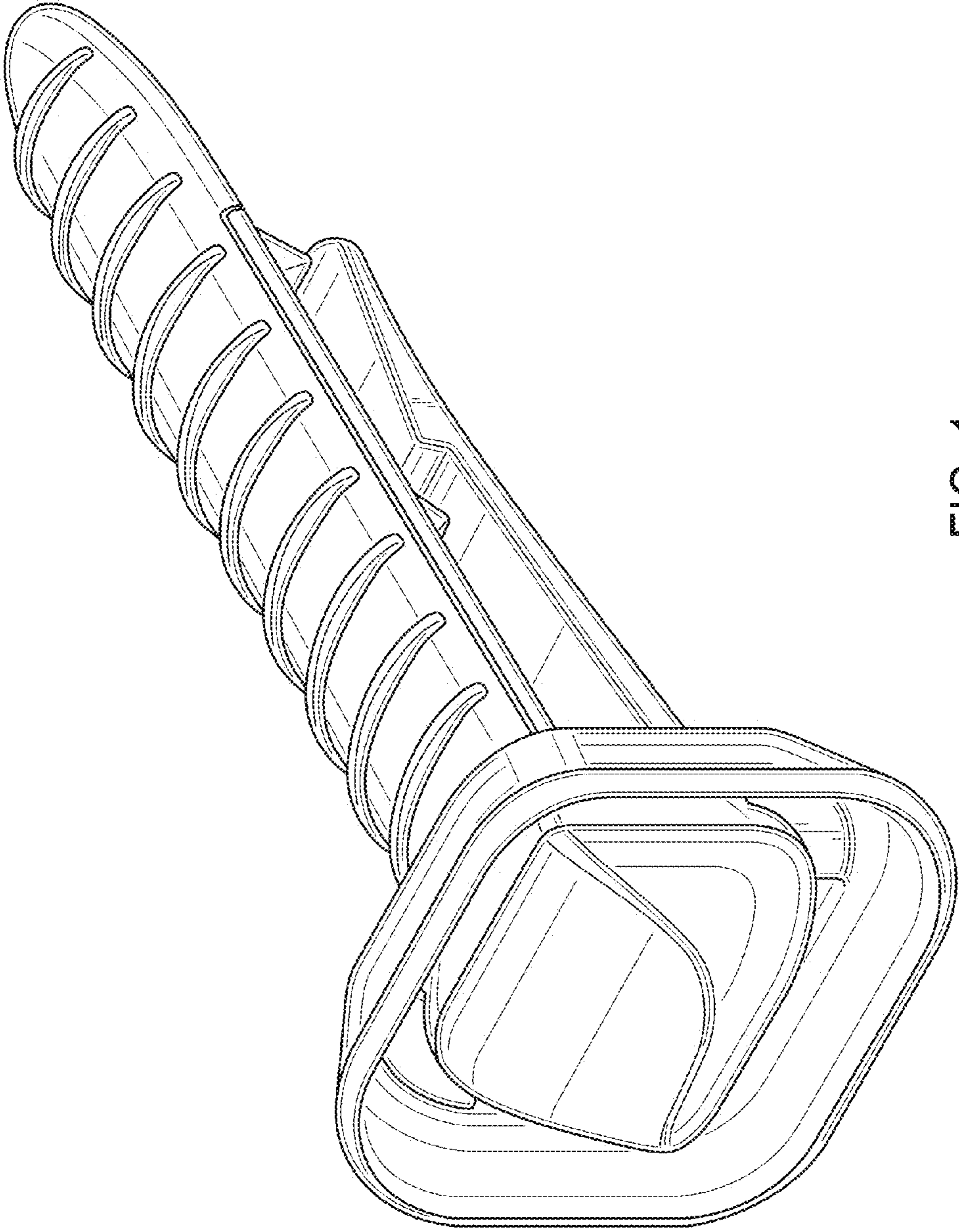

FIG. 1

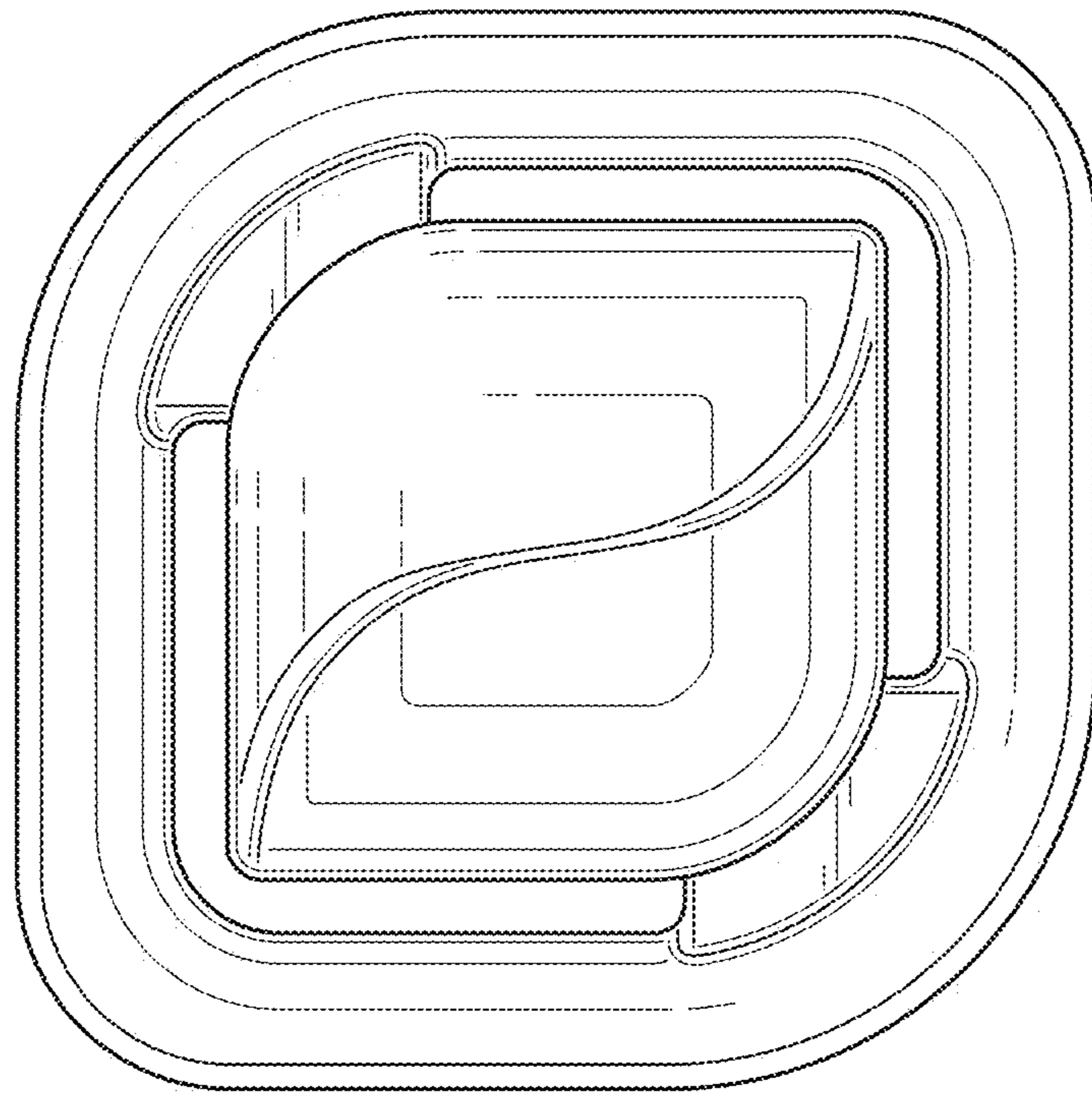

FIG. 2

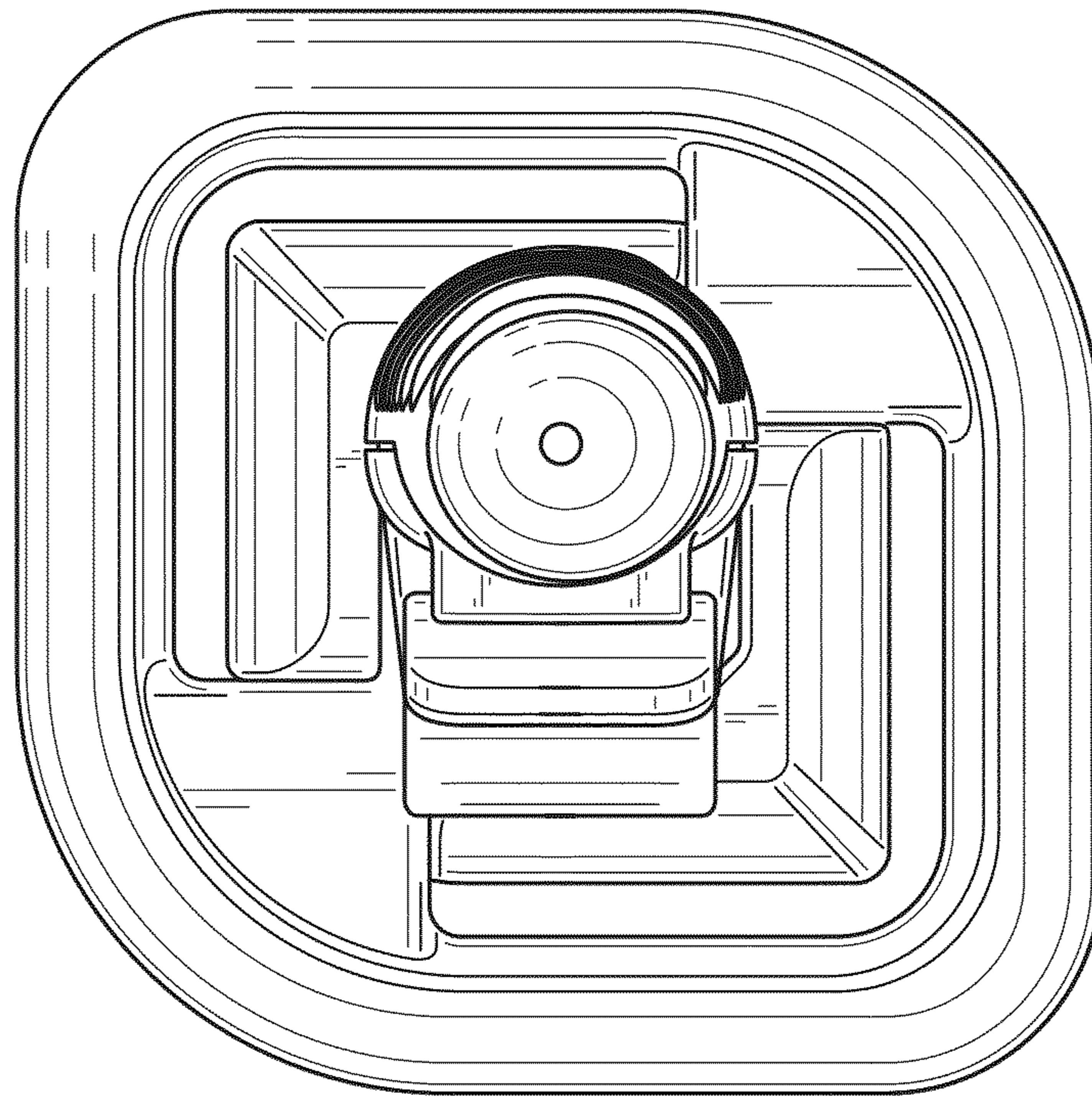

FIG. 3

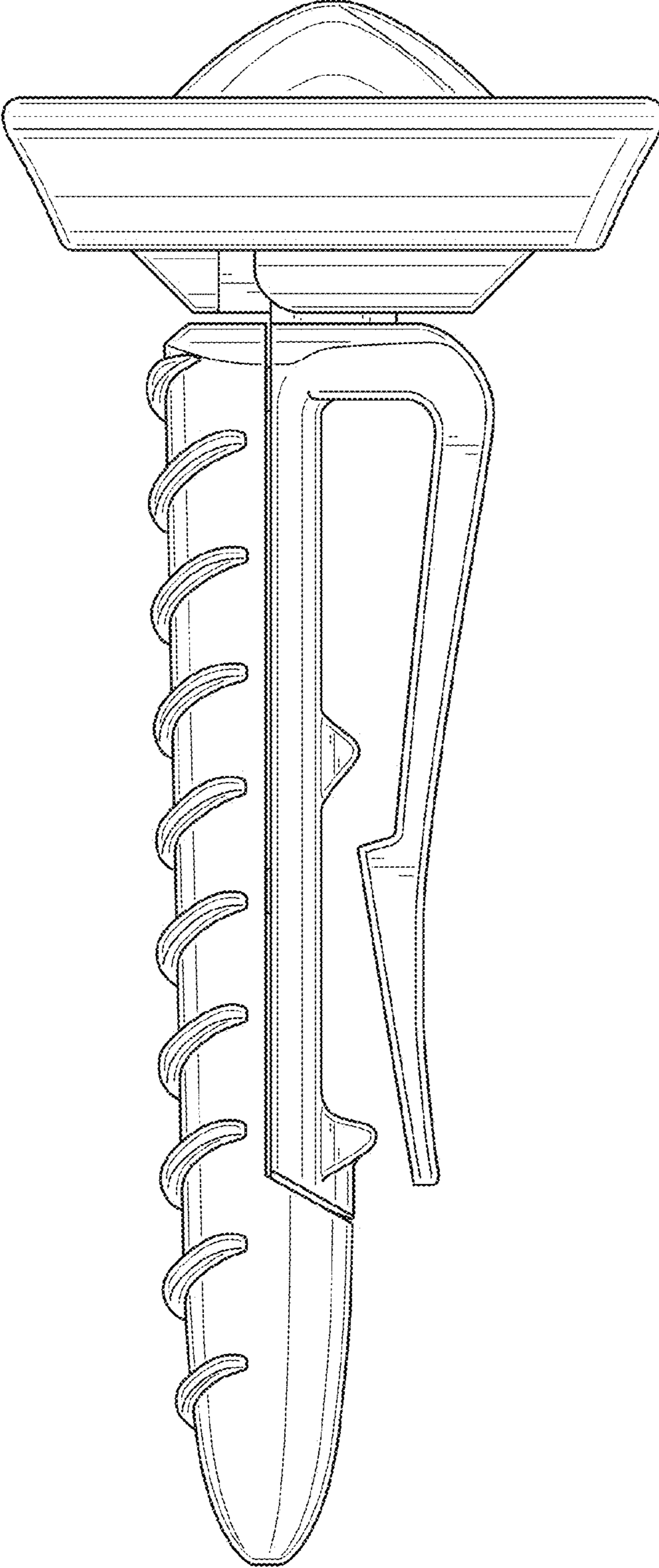

FIG. 4

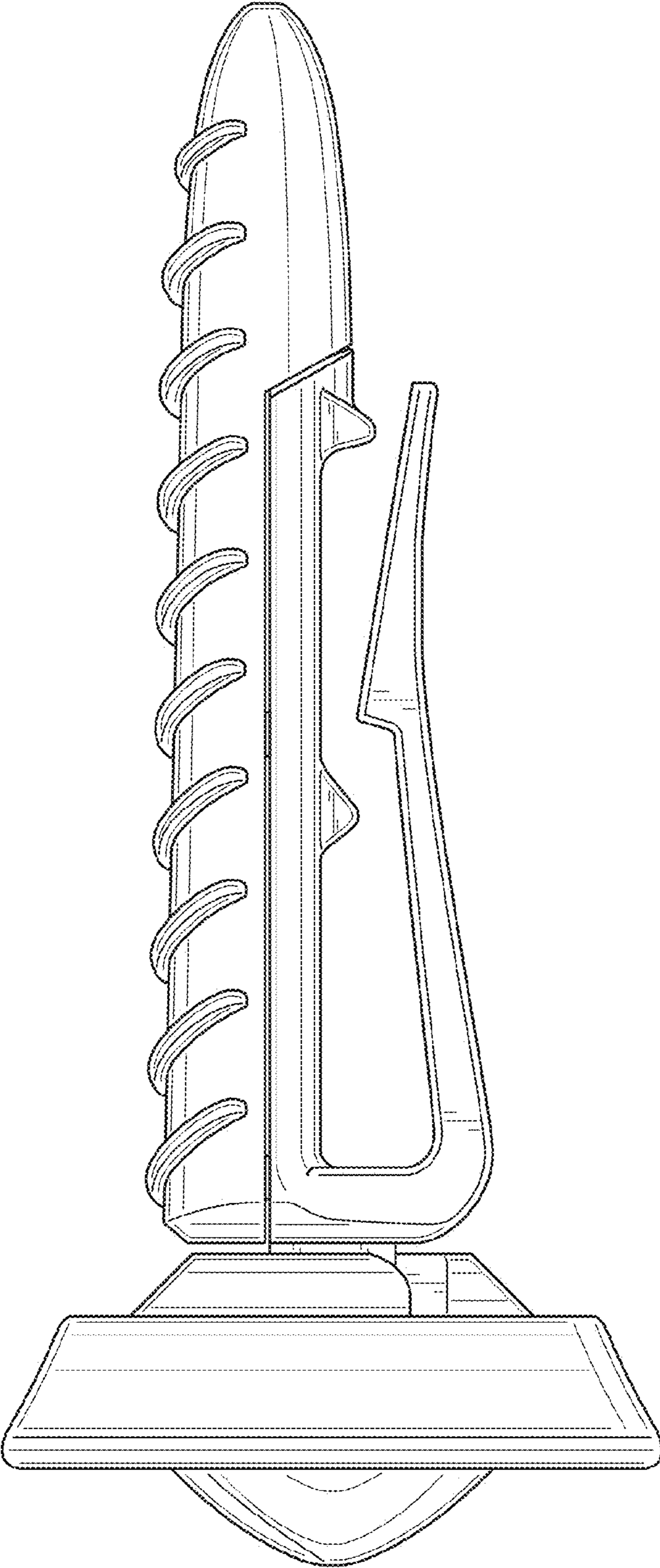

FIG. 5

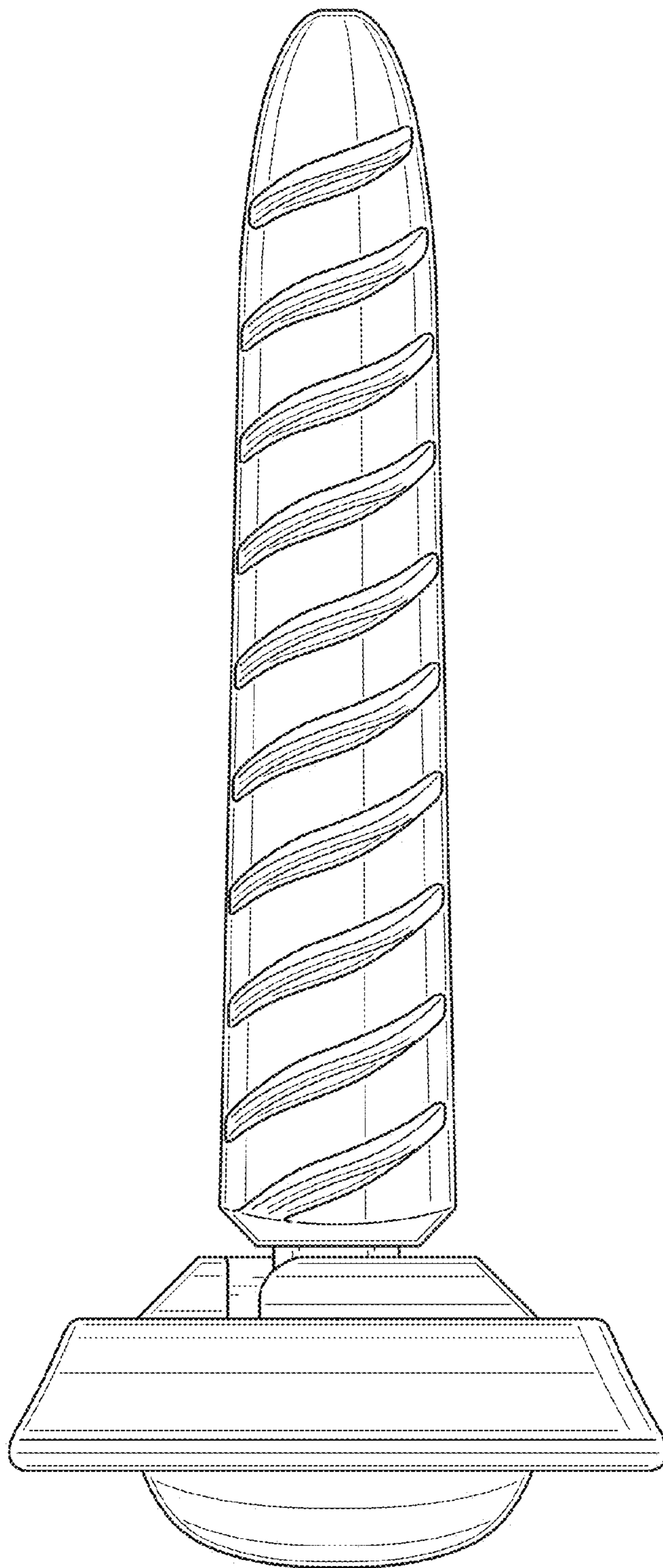

FIG. 6

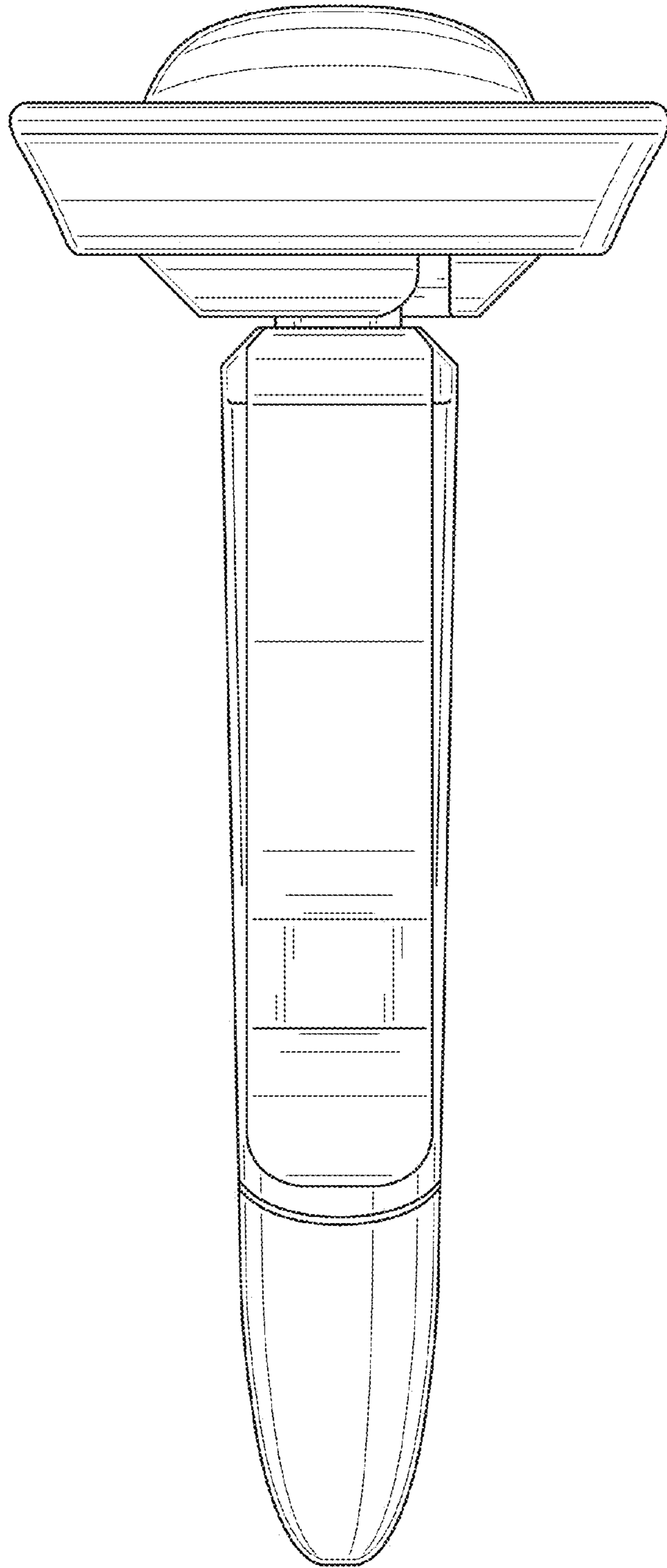

FIG. 7