



US00D715327S

(12) **United States Design Patent**
Lim et al.

(10) **Patent No.:** **US D715,327 S**
(45) **Date of Patent:** **** Oct. 14, 2014**

(54) **COMPRESSOR FOR VEHICLES**
(71) Applicant: **Halla Visteon Climate Control Corp.**,
Daejeon (KR)
(72) Inventors: **Kweon Soo Lim**, Daejeon (KR); **Min**
Gyu Kim, Daejeon (KR); **Jung Jae Lee**,
Daejeon (KR)
(73) Assignee: **Halla Visteon Climate Control Corp.**,
Daejeon (KR)

D440,232 S * 4/2001 Kou D15/9
D441,377 S * 5/2001 Kawaguchi et al. D15/9
D441,378 S * 5/2001 Kou D15/9
D456,029 S * 4/2002 Kawaguchi et al. D15/9
D456,423 S * 4/2002 Kanou et al. D15/9
D460,460 S * 7/2002 Kayukawa et al. D15/9
6,532,859 B1 * 3/2003 Kuhn et al. 92/71
D479,534 S * 9/2003 Shiina D15/9
D573,159 S * 7/2008 Etter D15/7
D695,789 S * 12/2013 Nam D15/9

(**) Term: **14 Years**

* cited by examiner
Primary Examiner — Ralf Seifert
(74) *Attorney, Agent, or Firm* — Dickinson Wright PLLC

(21) Appl. No.: **29/483,541**

(22) Filed: **Feb. 28, 2014**

(51) **LOC (10) Cl.** **15-02**

(52) **U.S. Cl.**
USPC **D15/9**

(58) **Field of Classification Search**
CPC F01D 5/14; F01D 5/12; F01D 5/04;
F02B 33/40; F04D 29/42
USPC D15/7-9; D23/231, 232, 225; 417/60,
417/235, 265, 321, 355, 358, 363, 359,
417/410.1, 415-416, 405, 900, 231, 313,
417/273, 539; 60/408, 412; 184/26-37;
415/140-147; 123/495, 509; 418/259
See application file for complete search history.

(57) **CLAIM**
We claim the ornamental design for a compressor for
vehicles, as shown herein.

DESCRIPTION

FIG. 1 is a perspective view of a compressor for vehicles
according to the present design;
FIG. 2 is a front view of the compressor for vehicles accord-
ing to the present design;
FIG. 3 is a rear view of the compressor for vehicles according
to the present design;
FIG. 4 is a left side view of the compressor for vehicles
according to the present design;
FIG. 5 is a right side view of the compressor for vehicles
according to the present design;
FIG. 6 is a plan view of the compressor for vehicles according
to the present design; and,
FIG. 7 is a bottom view of the compressor for vehicles accord-
ing to the present design.
The broken lines in FIG. 6 are included for the purposes of
illustrating portions of the compressor for vehicles that form
no part of the claimed design.

(56) **References Cited**
U.S. PATENT DOCUMENTS

D351,603 S * 10/1994 Ikeda et al. D15/9
5,470,207 A * 11/1995 Shockey et al. 417/313
D381,340 S * 7/1997 Takenaka et al. D15/9
D381,993 S * 8/1997 Takenaka et al. D15/9
5,674,054 A * 10/1997 Ota et al. 417/269
D429,738 S * 8/2000 Kayukawa et al. D15/9
D432,139 S * 10/2000 Chisenhall D15/9

1 Claim, 7 Drawing Sheets

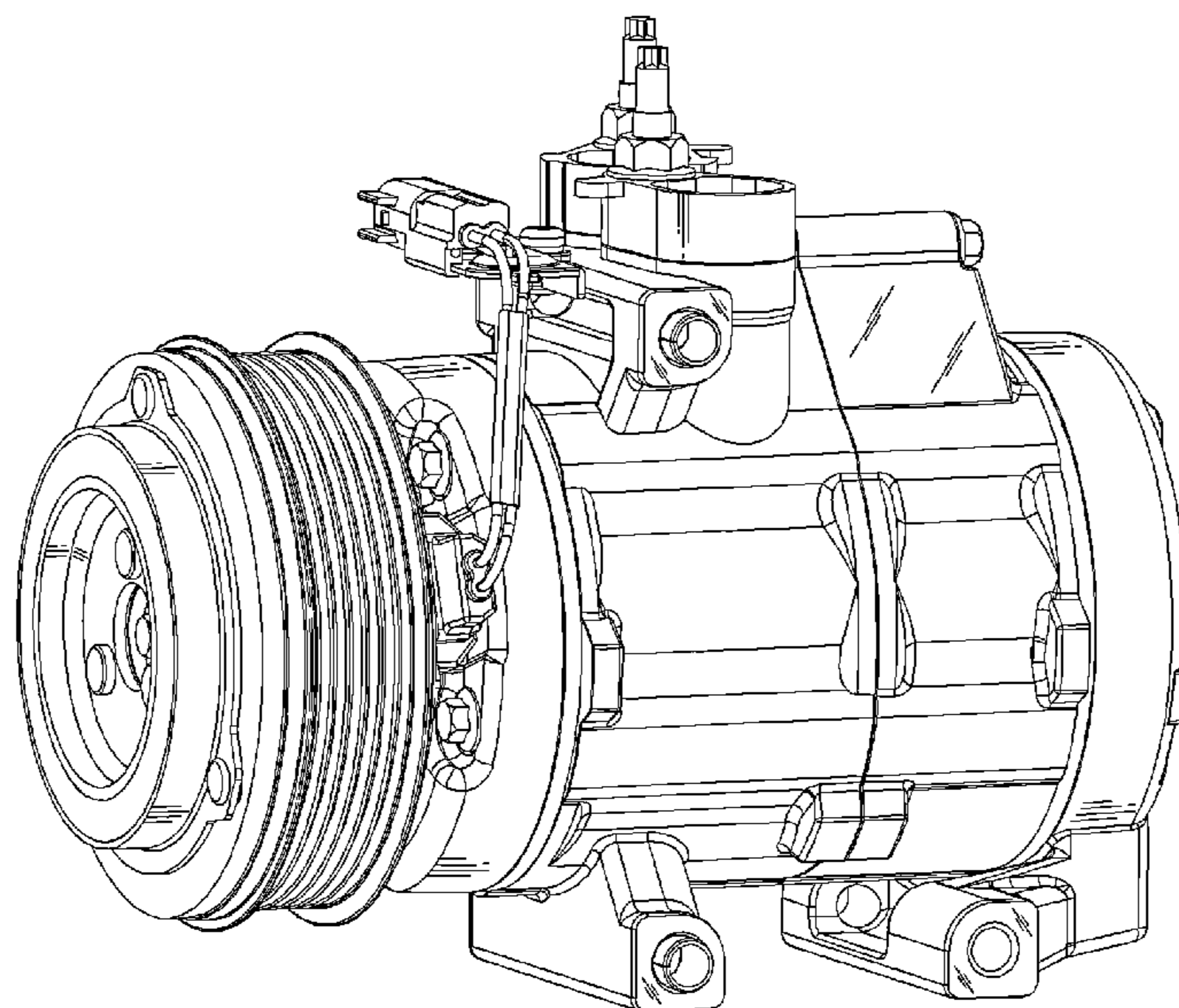

Fig. 1

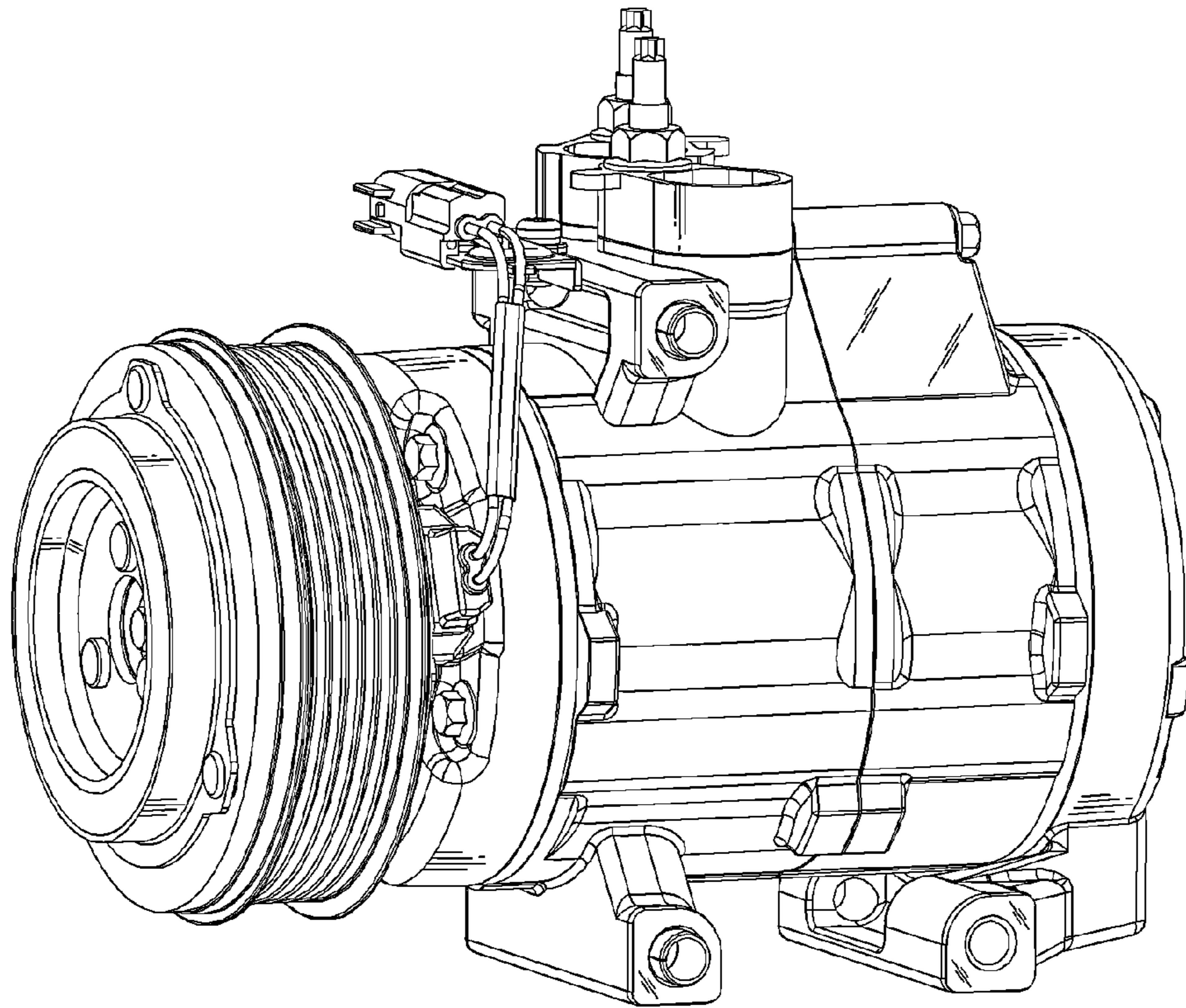

Fig. 2

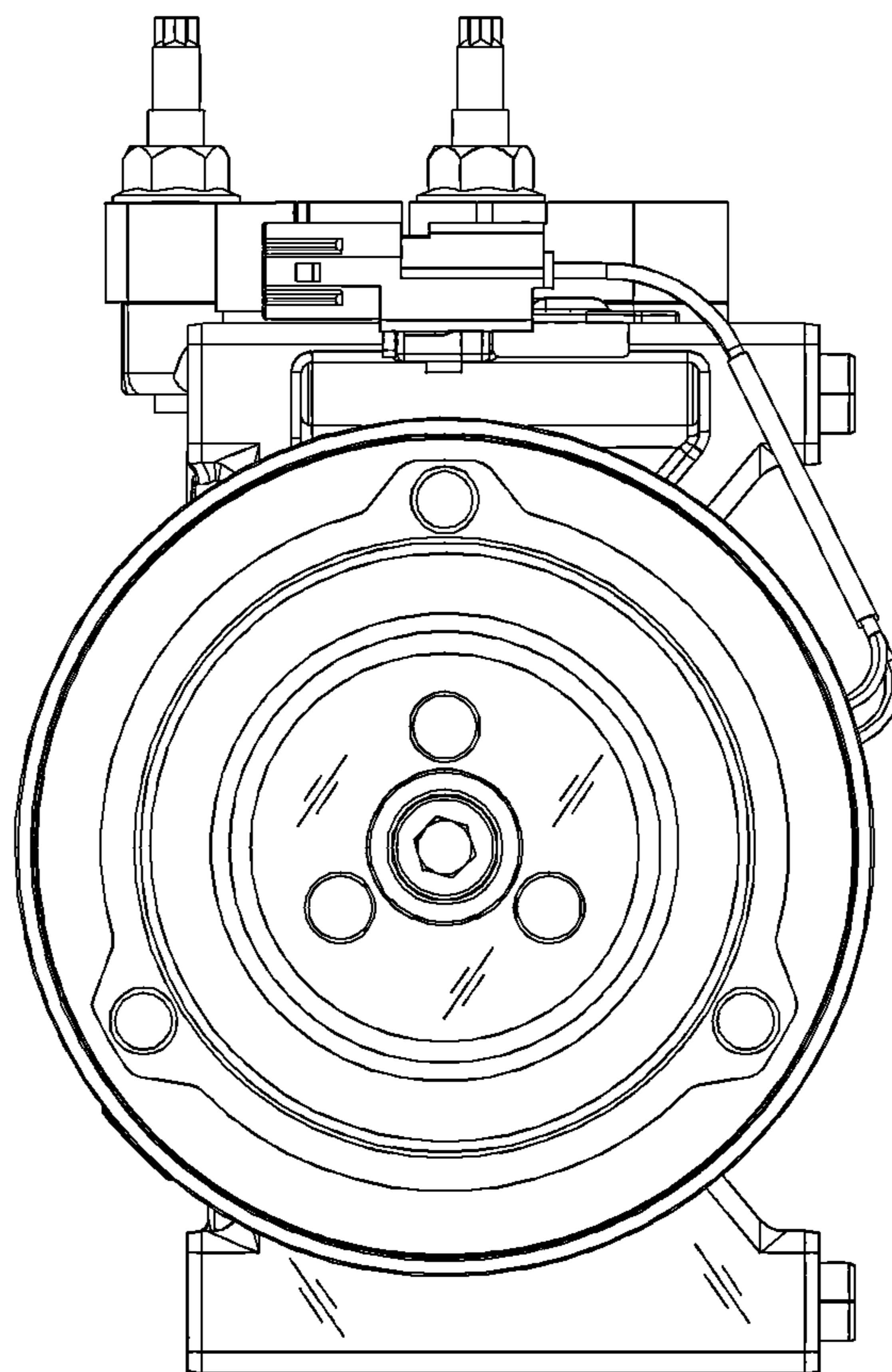

Fig. 3

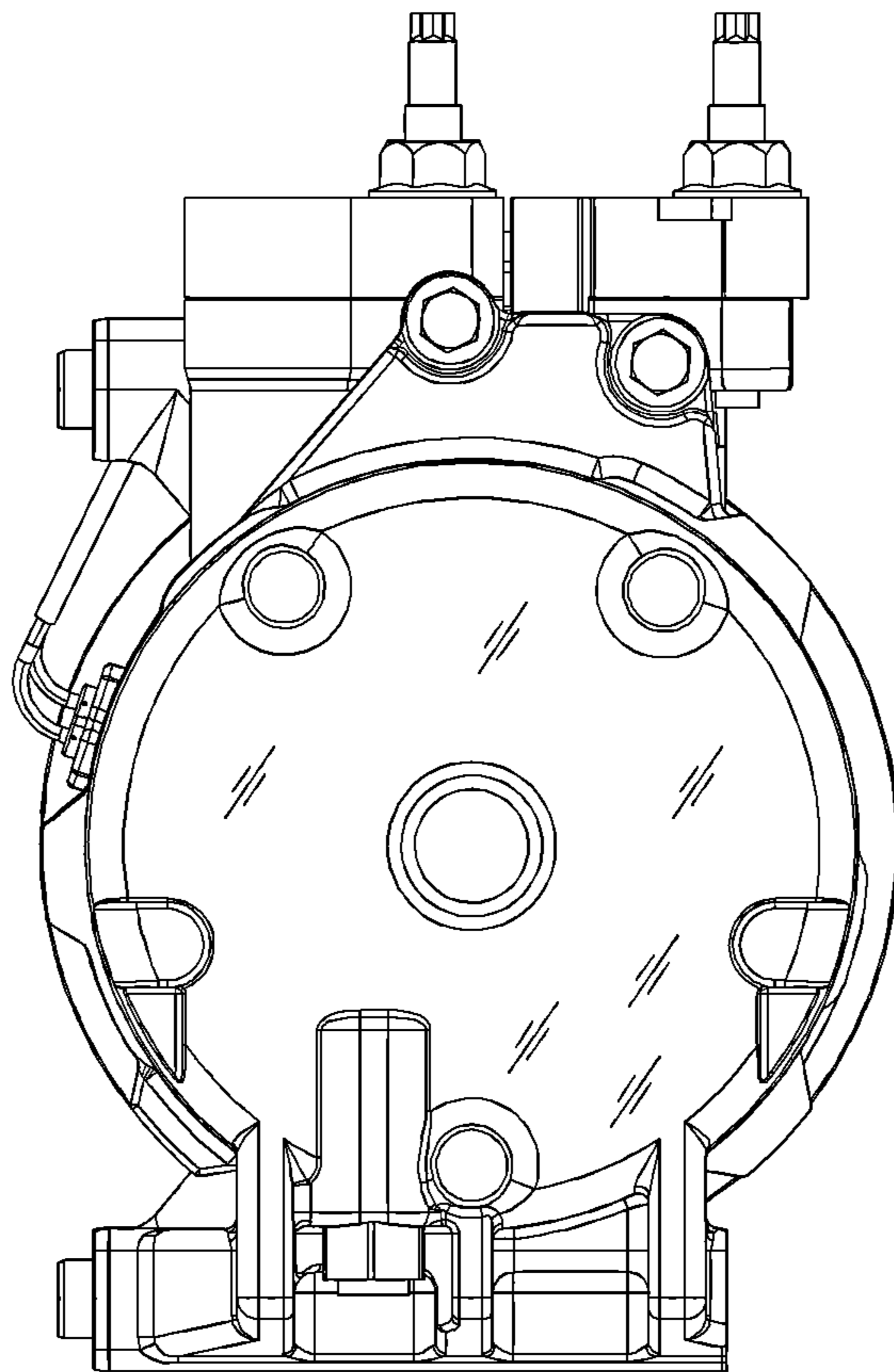

Fig. 4

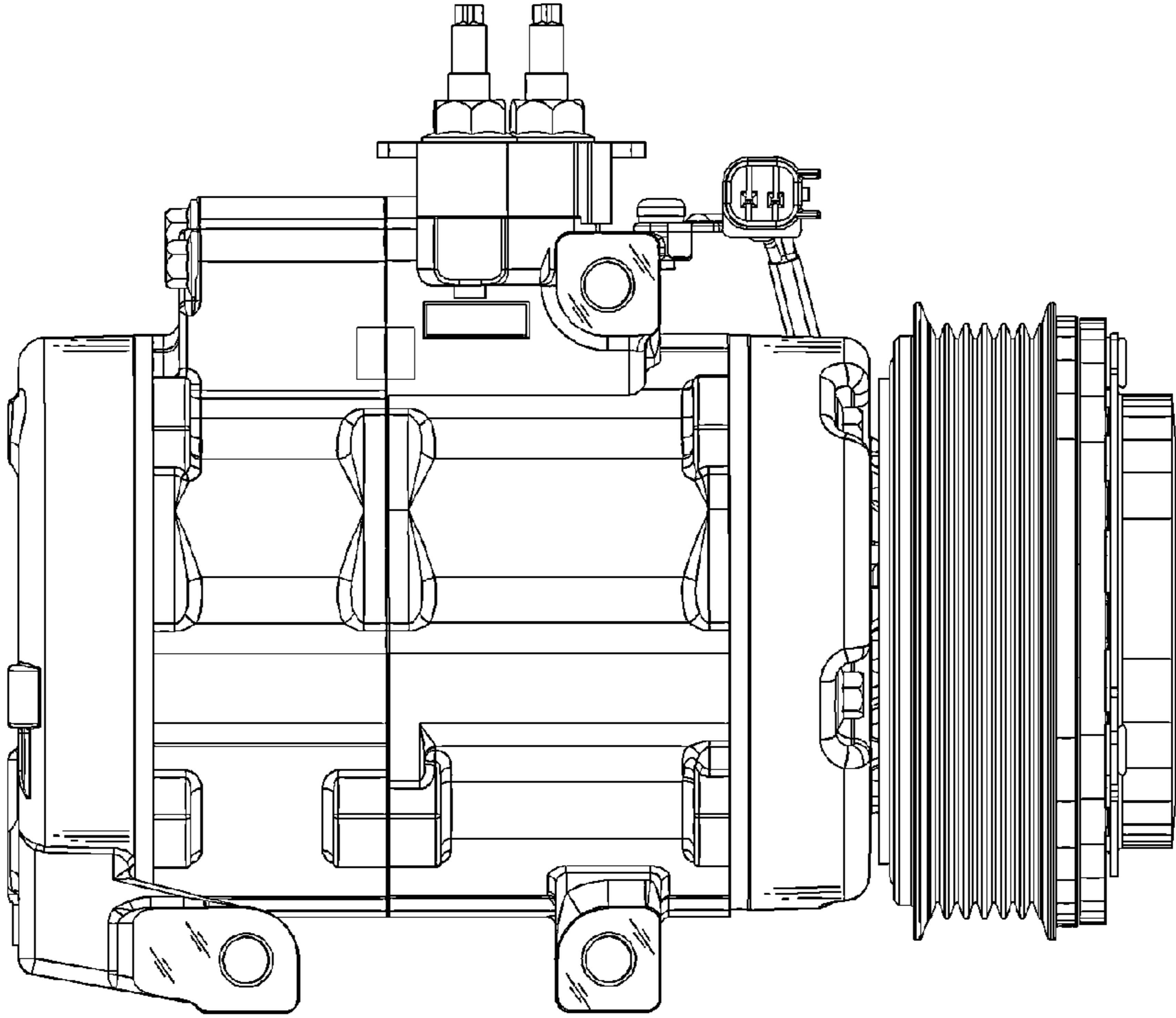

Fig. 5

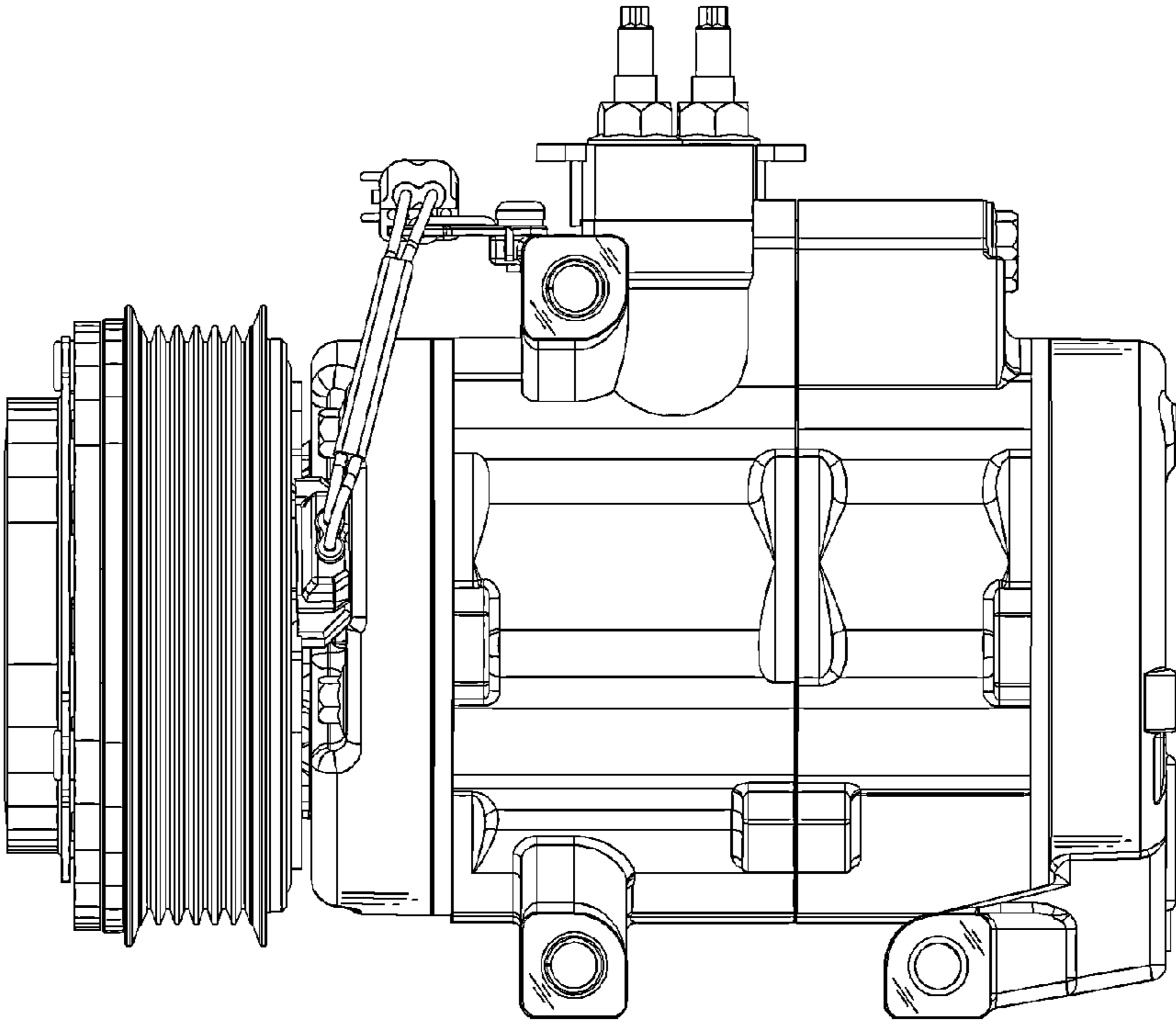

Fig. 6

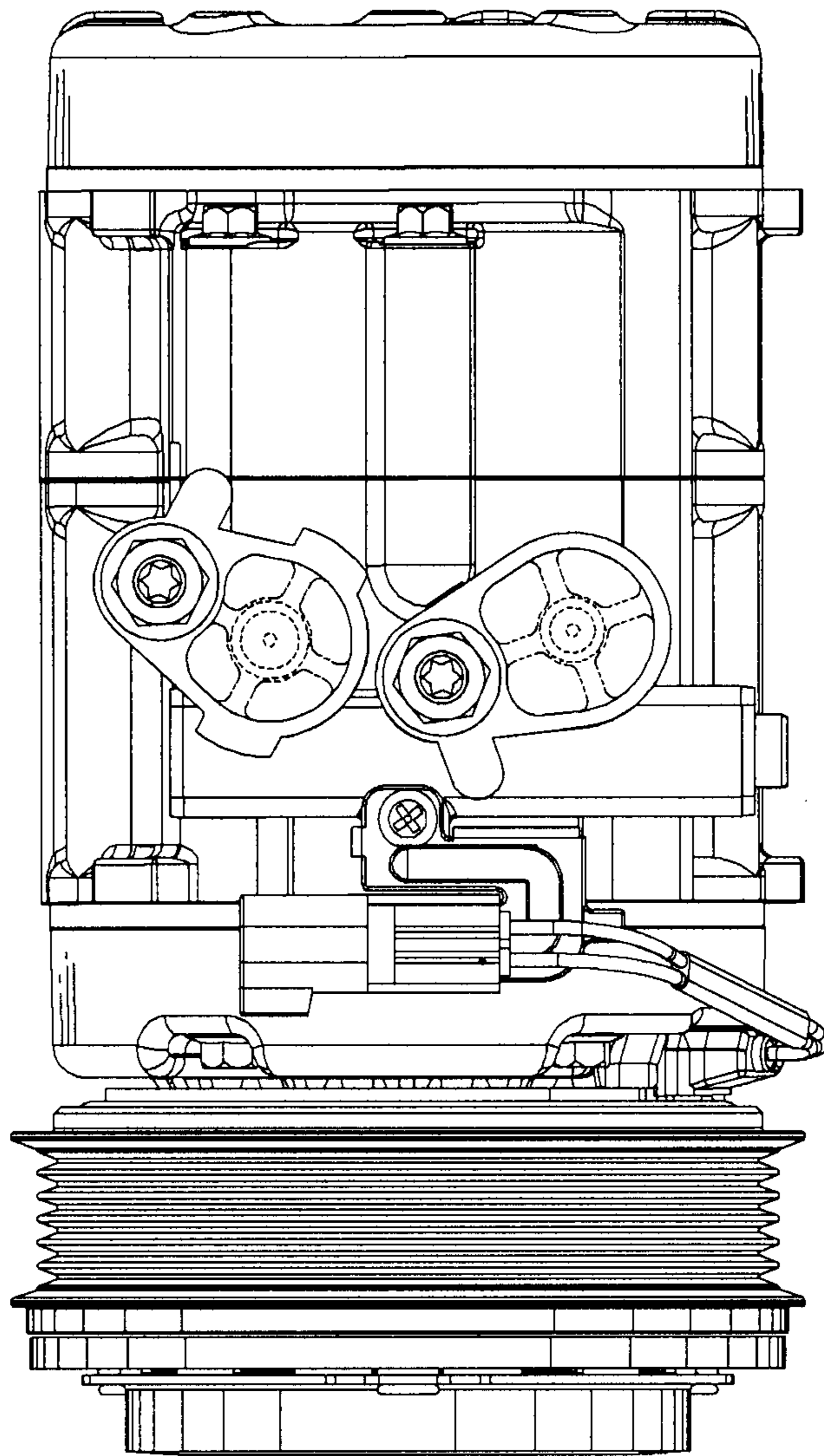

Fig. 7

