



US00D714878S

(12) **United States Design Patent**  
**Bean et al.**

(10) **Patent No.:** **US D714,878 S**

(45) **Date of Patent:** **\*\* Oct. 7, 2014**

(54) **FRAME OF A THREE-WHEELED VEHICLE**

(71) Applicant: **Huffy Corporation**, Centerville, OH (US)

(72) Inventors: **Andrew Bean**, Cincinnati, OH (US);  
**Douglas Barchek**, Centerville, OH (US);  
**Jason Jewell**, Fairborn, OH (US);  
**Jeremy Humble**, Beavercreek, OH (US)

(\*\*) Term: **14 Years**

(21) Appl. No.: **29/444,689**

(22) Filed: **Feb. 1, 2013**

(51) **LOC (10) Cl.** ..... **21-01**

(52) **U.S. Cl.**  
USPC ..... **D21/435**; D12/179

(58) **Field of Classification Search**  
USPC ..... D21/412, 414, 431-435; D12/1, 107,  
D12/110-114, 129, 130, 133, 179;  
280/87.01, 87.021, 87.05, 87.051,  
280/47.17, 47.25, 47.34, 47.38, 47.4, 827,  
280/828, 29, 200, 263, 266, 267, 270, 282,  
280/288.4, 291, 293; 297/5; 482/68  
See application file for complete search history.

(56) **References Cited**

**U.S. PATENT DOCUMENTS**

D251,264	S	*	3/1979	Cook et al.	.....	D12/112
4,168,846	A	*	9/1979	Carren	.....	280/278
D263,944	S	*	4/1982	Arad et al.	.....	D12/112
4,580,802	A	*	4/1986	Herman et al.	.....	280/267
D480,024	S	*	9/2003	Gunter et al.	.....	D12/112
D480,665	S	*	10/2003	Gunter et al.	.....	D12/112
D484,073	S	*	12/2003	Heinemann et al.	.....	D12/112

D493,391	S	*	7/2004	Gunter	.....	D12/112
D498,709	S	*	11/2004	Sramek	.....	D12/112
D514,476	S	*	2/2006	Glenn, II	.....	D12/112
D524,699	S	*	7/2006	Kurth et al.	.....	D12/112
D582,489	S	*	12/2008	Badanjo	.....	D21/435
D630,158	S	*	1/2011	Jessie, Jr.	.....	D12/423
D645,381	S	*	9/2011	Bricker et al.	.....	D12/112
D682,746	S	*	5/2013	Doherty et al.	.....	D12/112

\* cited by examiner

*Primary Examiner* — Cynthia M Chin

(74) *Attorney, Agent, or Firm* — Wood, Herron & Evans, LLP

(57) **CLAIM**

The ornamental design for a frame of a three-wheeled vehicle, as shown and described.

**DESCRIPTION**

FIG. 1 is a left front perspective view of our new, original and ornamental design;  
FIG. 2 is another left front perspective view thereof;  
FIG. 3 is a left rear perspective view thereof;  
FIG. 4 is a left side view thereof, the right side view being a mirror image thereof;  
FIG. 5 is a front view thereof;  
FIG. 6 is a rear view thereof;  
FIG. 7 is a top view thereof; and,  
FIG. 8 is a bottom view thereof.  
The dash broken lines of the frame of a three-wheeled vehicle represent the bounds of the claimed design while the dash-dot broken lines are directed to environment and are for illustrative purposes only. The dash broken lines and the dash-dot broken lines form no part of the claimed design. Additionally, the unshown portion of the frame of a three-wheeled vehicle forms no part of the claimed design.

**1 Claim, 8 Drawing Sheets**

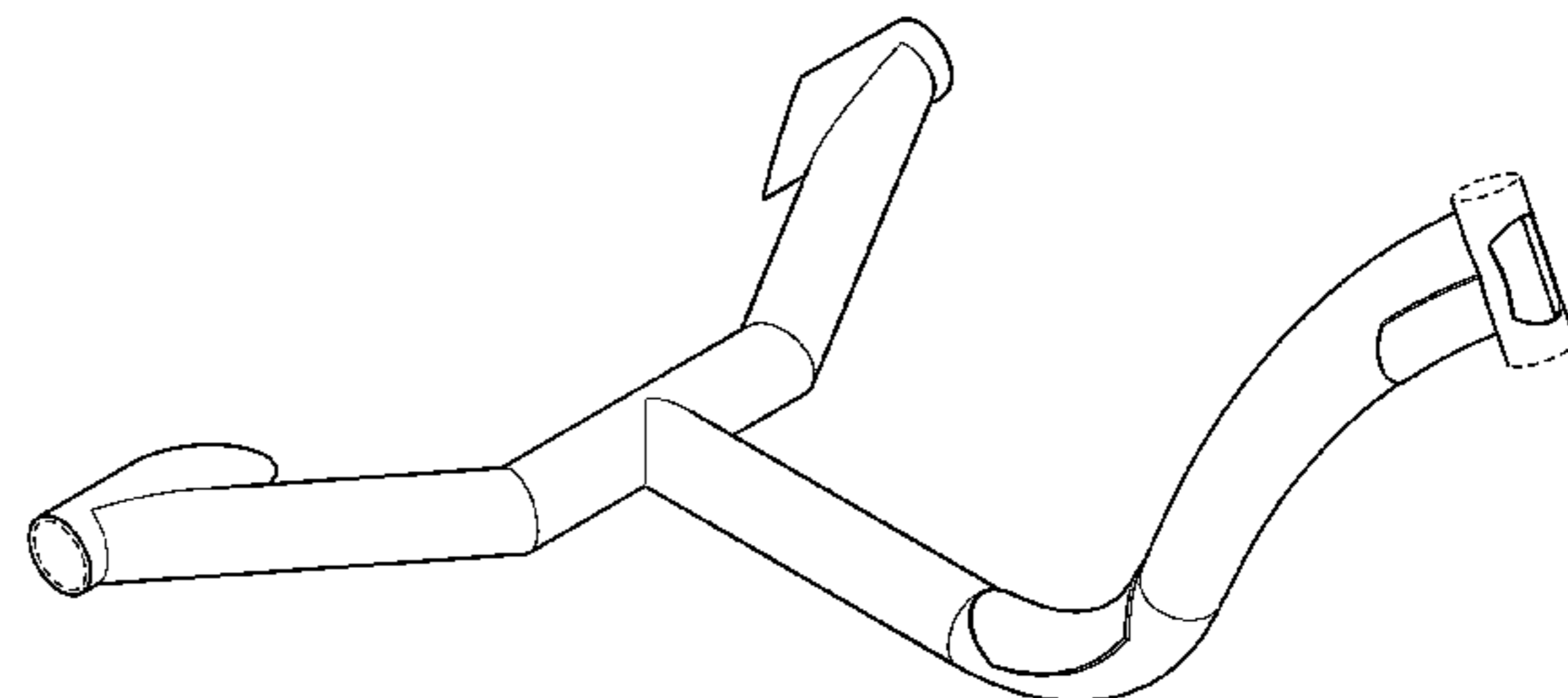
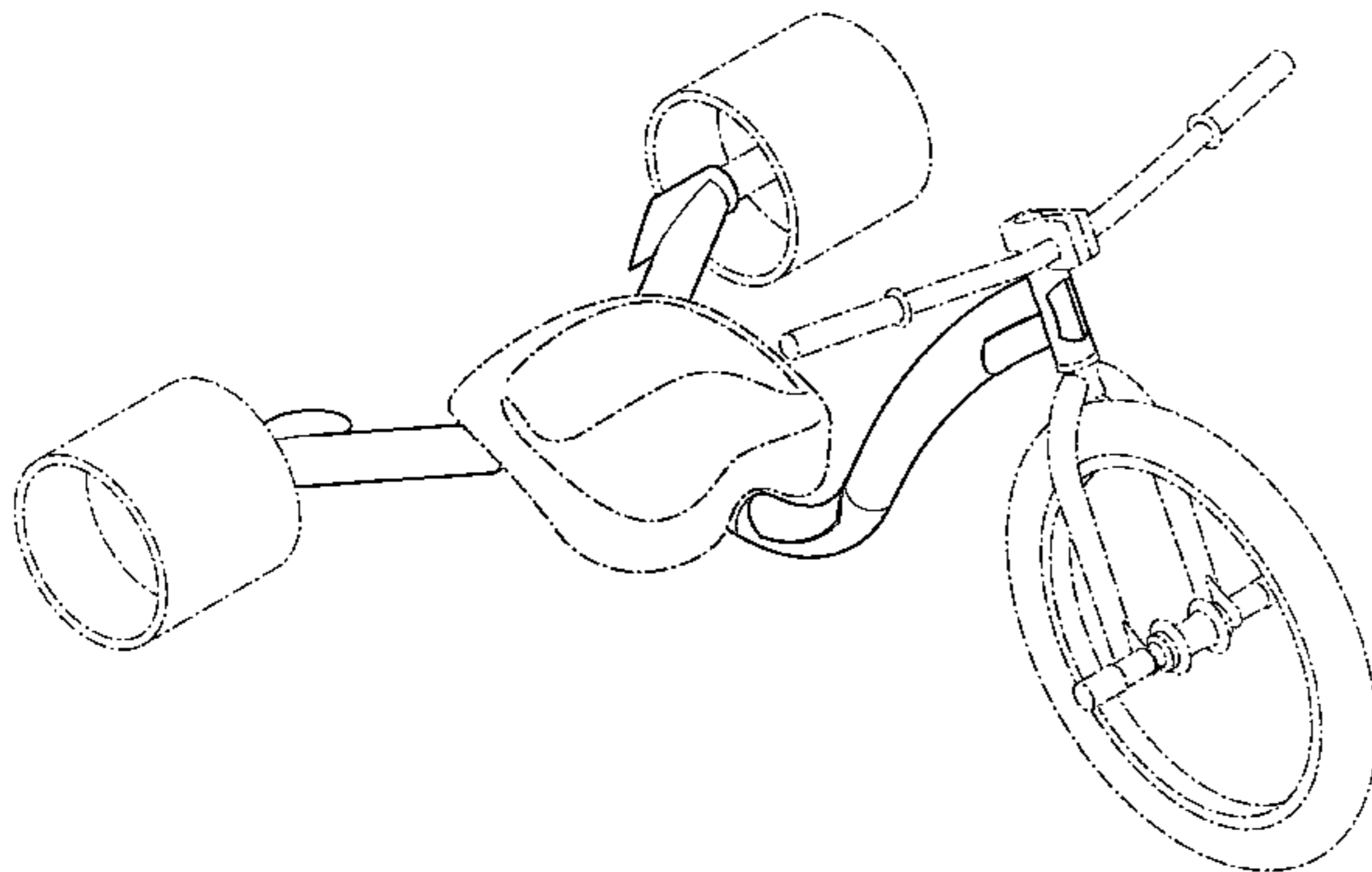

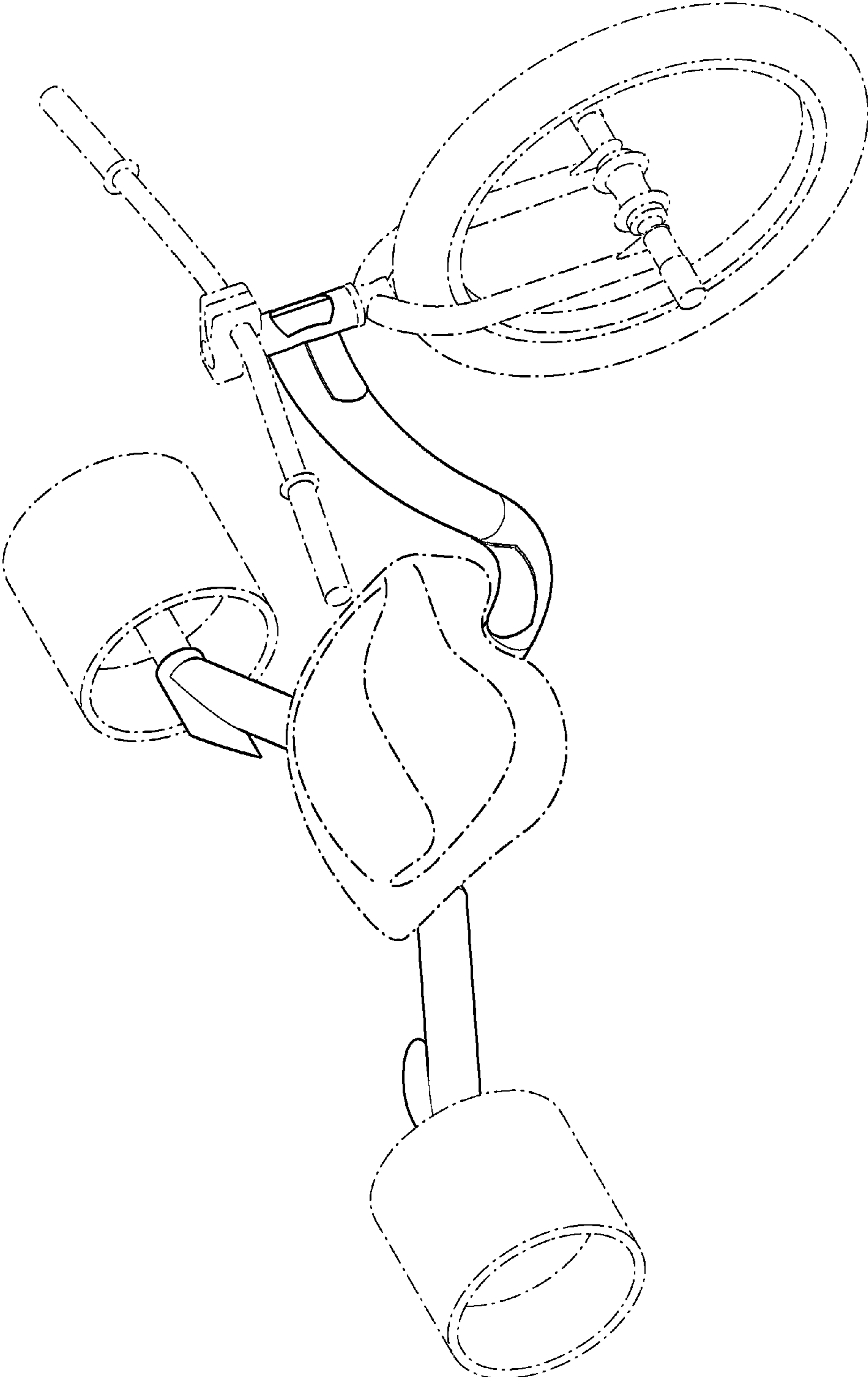

FIG. 1

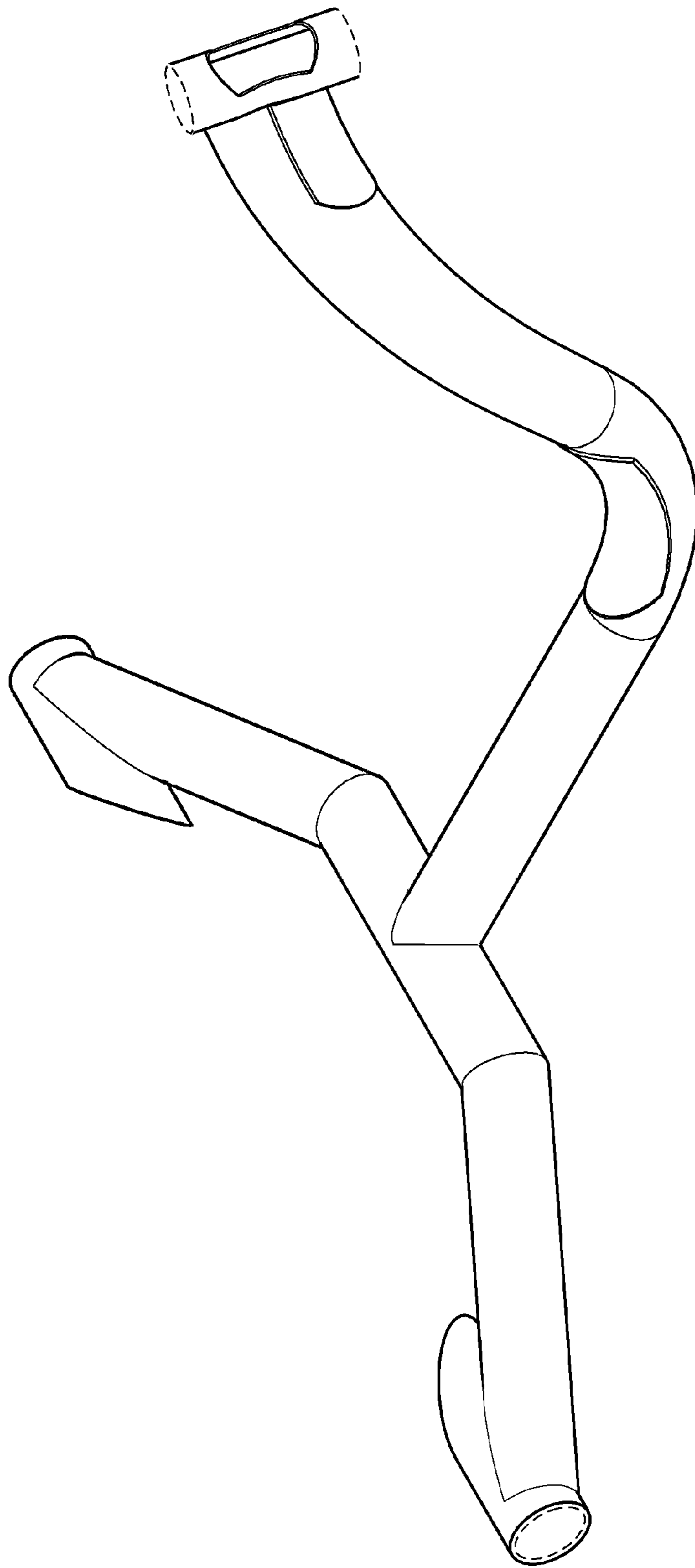

FIG. 2

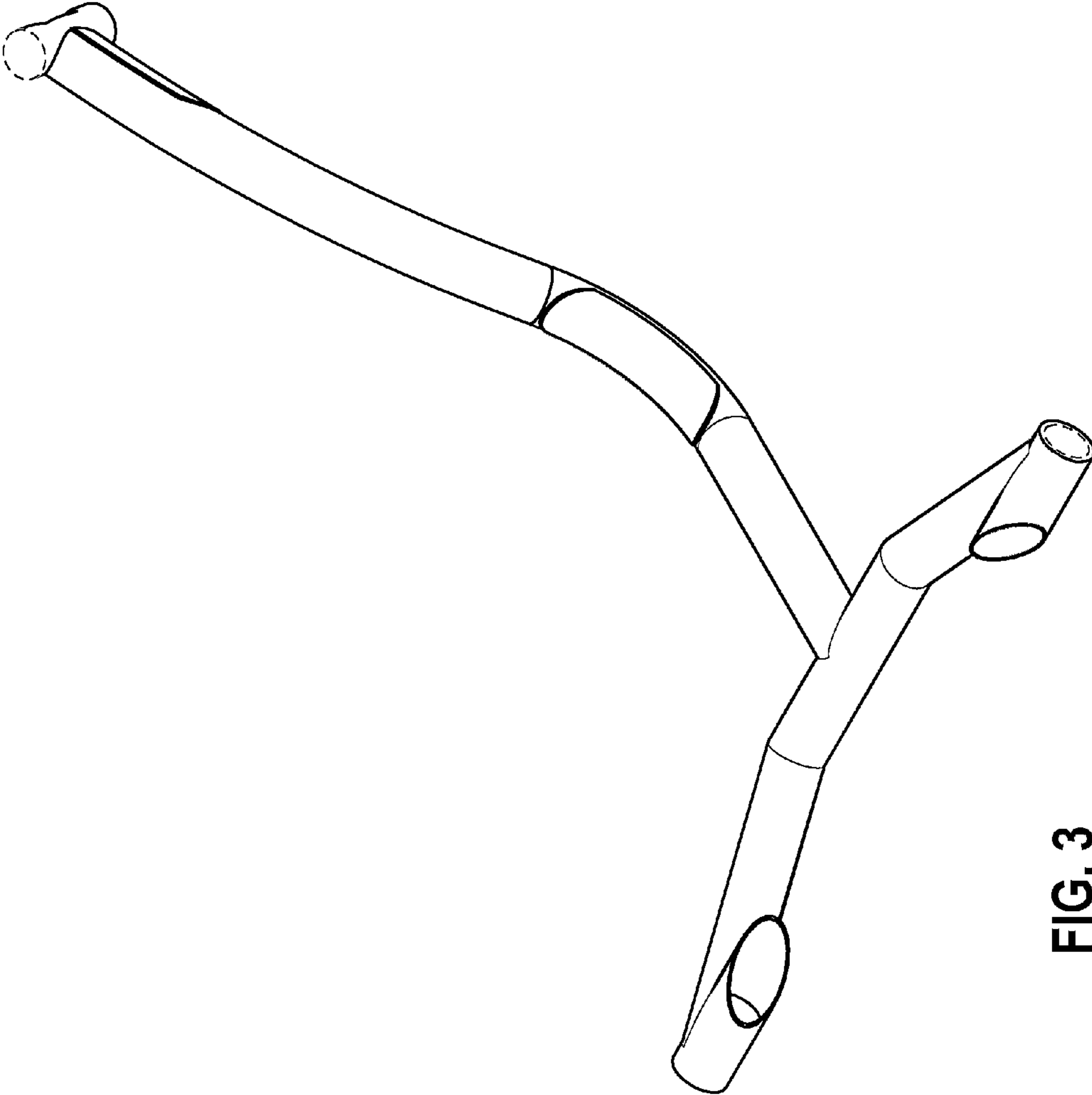

FIG. 3

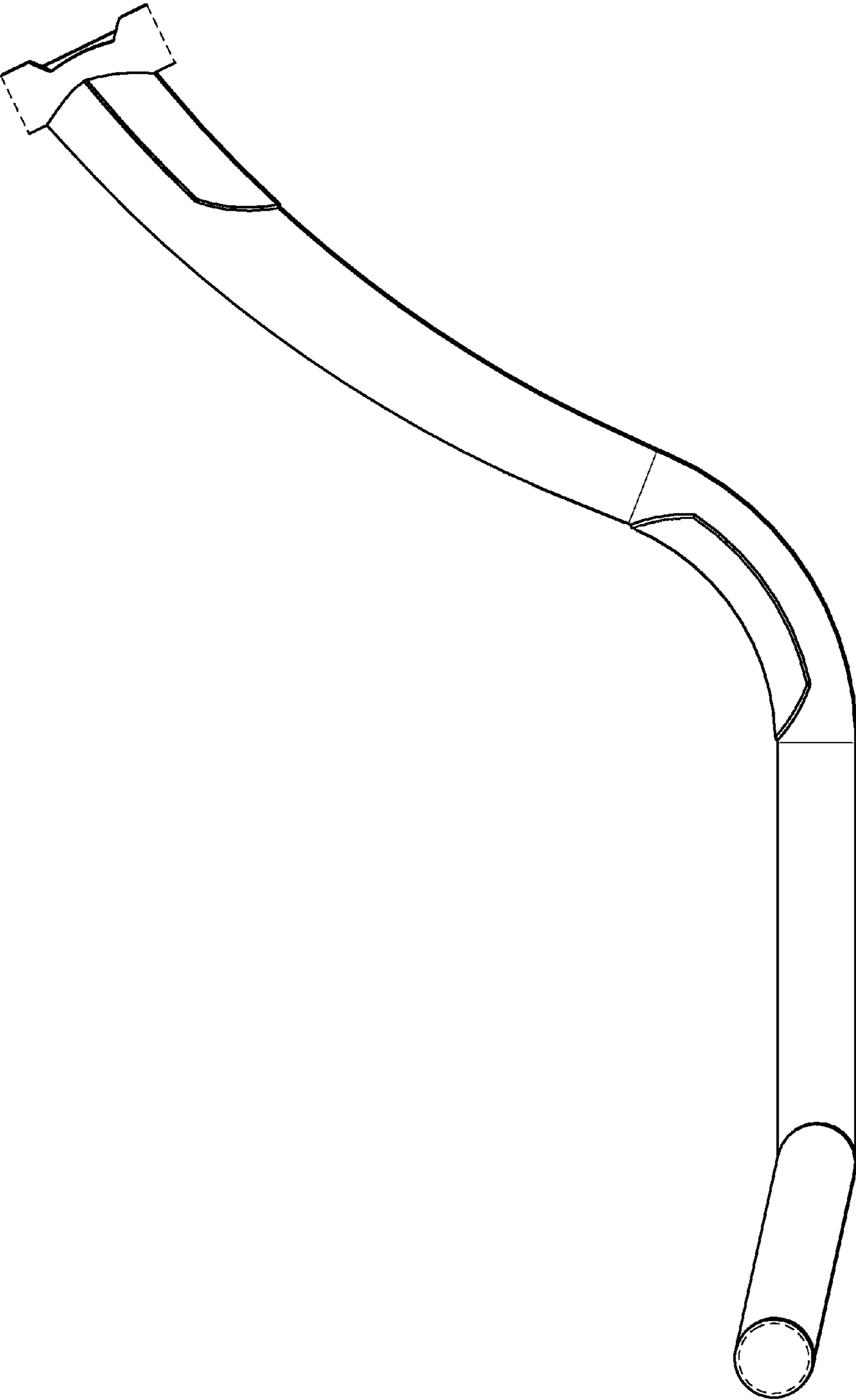

FIG. 4

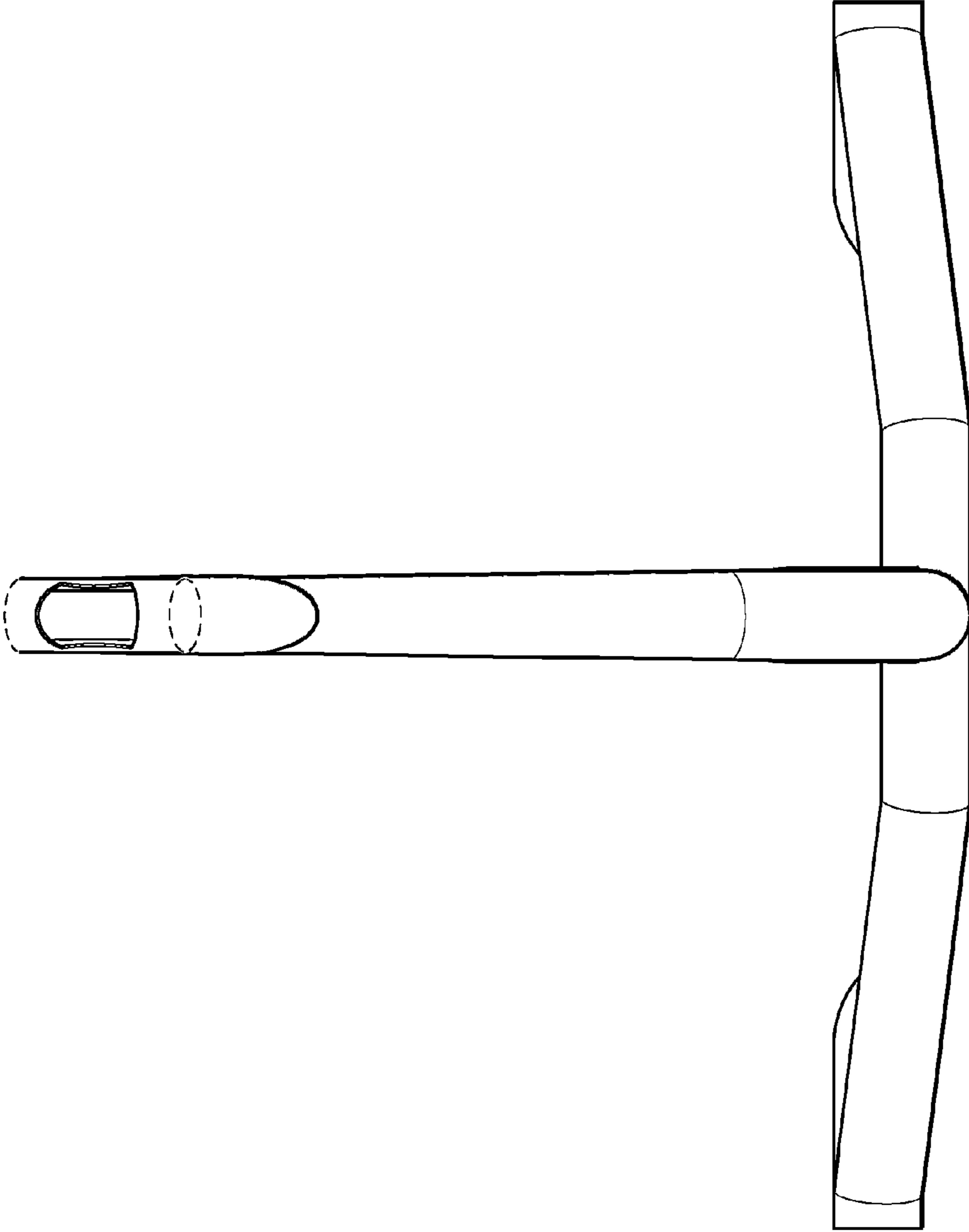

FIG. 5

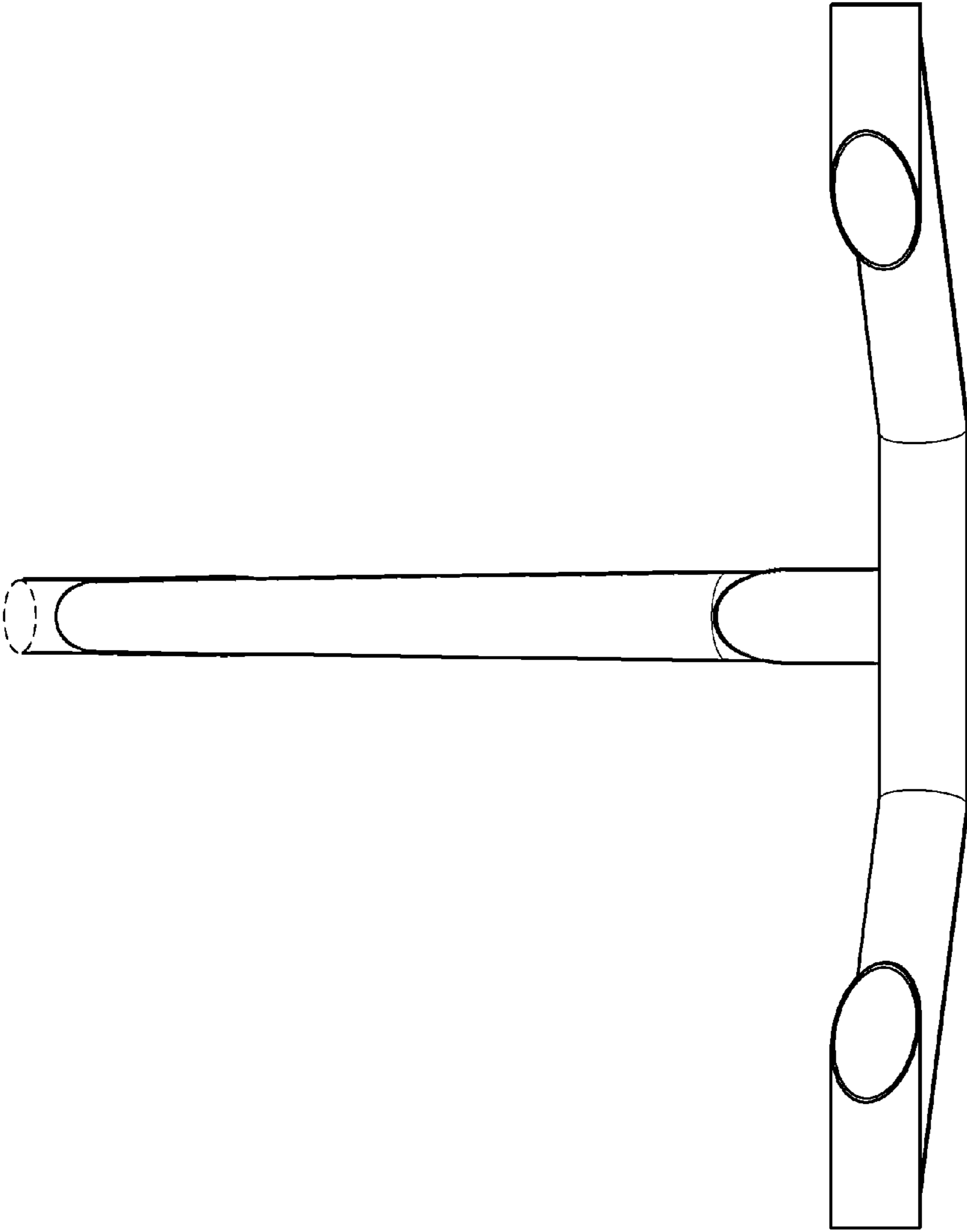

FIG. 6

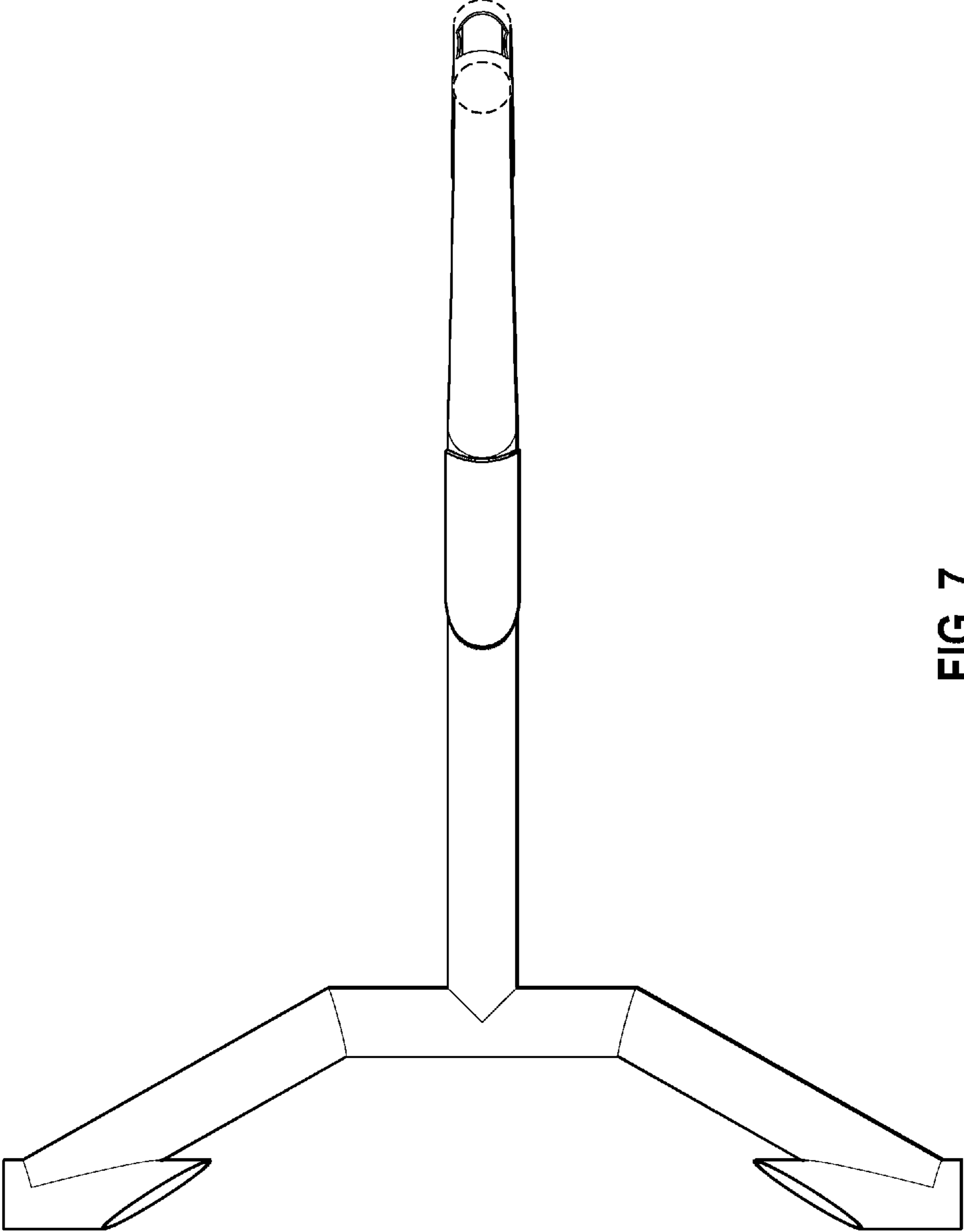

FIG. 7



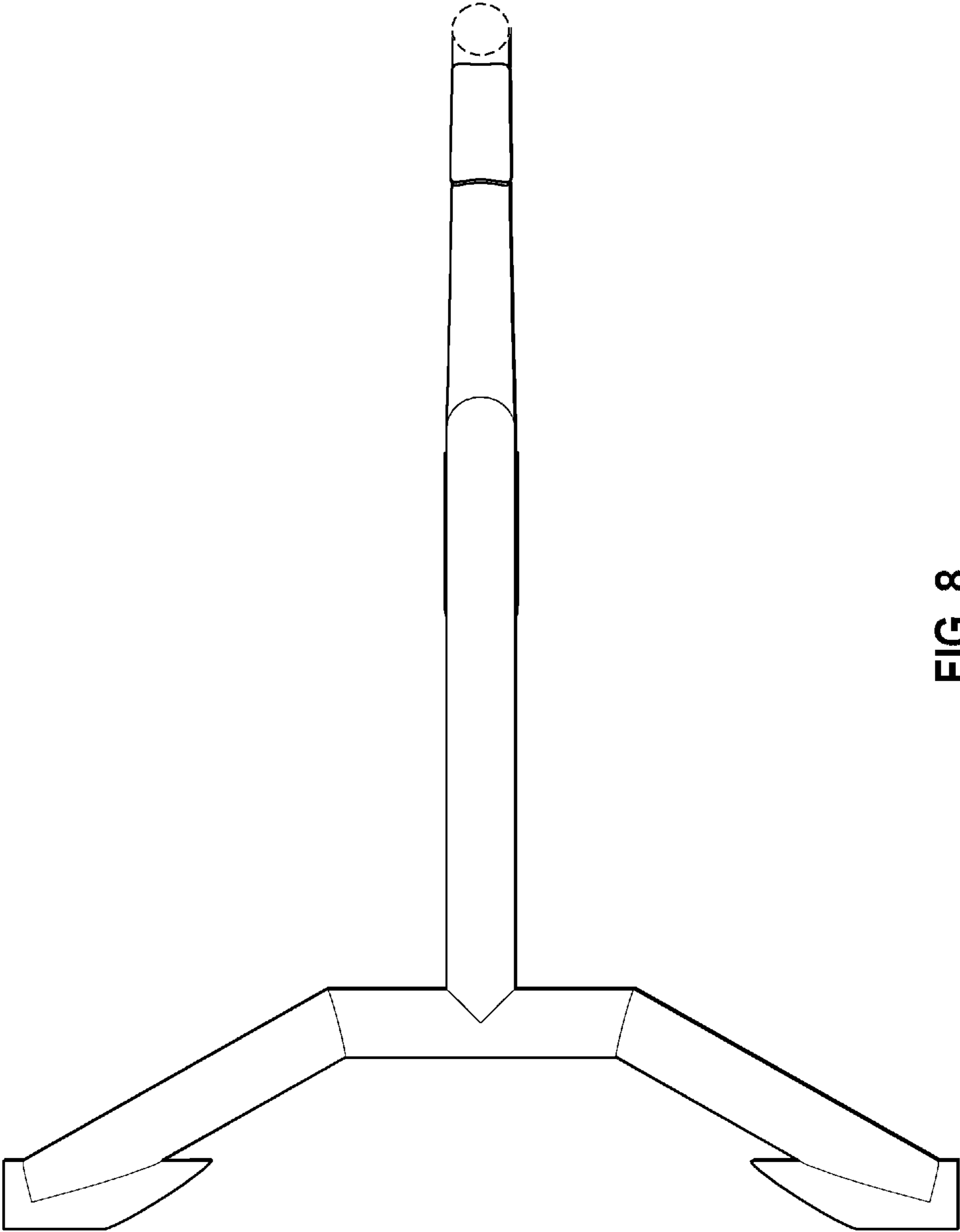

FIG. 8

UNITED STATES PATENT AND TRADEMARK OFFICE  
**CERTIFICATE OF CORRECTION**

PATENT NO. : D714,878 S  
APPLICATION NO. : 29/444689  
DATED : October 7, 2014  
INVENTOR(S) : Andrew Bean et al.

Page 1 of 1

It is certified that error appears in the above-identified patent and that said Letters Patent is hereby corrected as shown below:

On the title page add item (73), Assignee -- Huffy Corporation, Centerville, Ohio 45459 --

Signed and Sealed this  
Twenty-second Day of December, 2015



Michelle K. Lee  
*Director of the United States Patent and Trademark Office*