



US00D714828S

(12) **United States Design Patent**
Swanson et al.

(10) **Patent No.:** **US D714,828 S**
(45) **Date of Patent:** **** Oct. 7, 2014**

(54) **ADAPTER FOR A MODULAR VISCOUS FAN CLUTCH SYSTEM**

(71) Applicant: **Kit Masters**, Perham, MN (US)

(72) Inventors: **Craig Swanson**, Perham, MN (US);
Dale Scherman, Perham, MN (US)

(73) Assignee: **Kit Masters**, Perham, MN (US)

(**) Term: **14 Years**

(21) Appl. No.: **29/475,454**

(22) Filed: **Dec. 3, 2013**

Related U.S. Application Data

(63) Continuation of application No. 13/843,703, filed on Mar. 15, 2013.

(51) **LOC (10) Cl.** **15-01**

(52) **U.S. Cl.**
USPC **D15/5**

(58) **Field of Classification Search**
USPC D15/1-6, 148; D8/330, 331, 382, 387, D8/396; 123/41.12; 192/82 T, 84 C, 58.61, 192/58.8; 476/11; 29/592.1, 889.1, 889.3, 29/402.09, 804.08, 402.12, 402.14, 469, 29/428; 74/325

See application file for complete search history.

(56) **References Cited**

U.S. PATENT DOCUMENTS

3,186,530 A * 6/1965 Petroff 192/12 BA
D283,819 S * 5/1986 Brown D15/148
D398,984 S * 9/1998 Freeman D23/411

D462,256 S * 9/2002 Jaynes D8/382
D479,541 S * 9/2003 Lannoch D15/148
D479,542 S * 9/2003 Lannoch D15/148
2006/0243556 A1 * 11/2006 Houtman et al. 192/84.8
2007/0023248 A1 * 2/2007 Nguyen et al. 192/43

OTHER PUBLICATIONS

U.S. Appl. No. 29/475,484, filed Dec. 3, 2013, Swanson, et al.
U.S. Appl. No. 29/475,493, filed Dec. 3, 2013, Swanson, et al.

* cited by examiner

Primary Examiner — T. Chase Nelson

Assistant Examiner — Ania Aman

(74) *Attorney, Agent, or Firm* — Oblon, Spivak, McClelland, Maier & Neustadt, L.L.P.

(57) **CLAIM**

The ornamental design for an adapter for a modular viscous fan clutch system, as shown and described.

DESCRIPTION

FIG. 1 is a perspective view of an adapter for a modular viscous fan clutch system;
FIG. 2 is a front elevational view thereof;
FIG. 3 is a rear elevational view thereof;
FIG. 4 is a left side elevational view thereof, the right side elevational view thereof being a mirror image of the left side elevational view;
FIG. 5 is a top plan view thereof, the bottom plan view thereof being a mirror image of the top plan view; and,
FIG. 6 is a cross-sectional view thereof along the line 6-6 in FIG. 2.

The broken lines in the drawings depict environmental subject matter only and form no part of the claimed design.

1 Claim, 6 Drawing Sheets

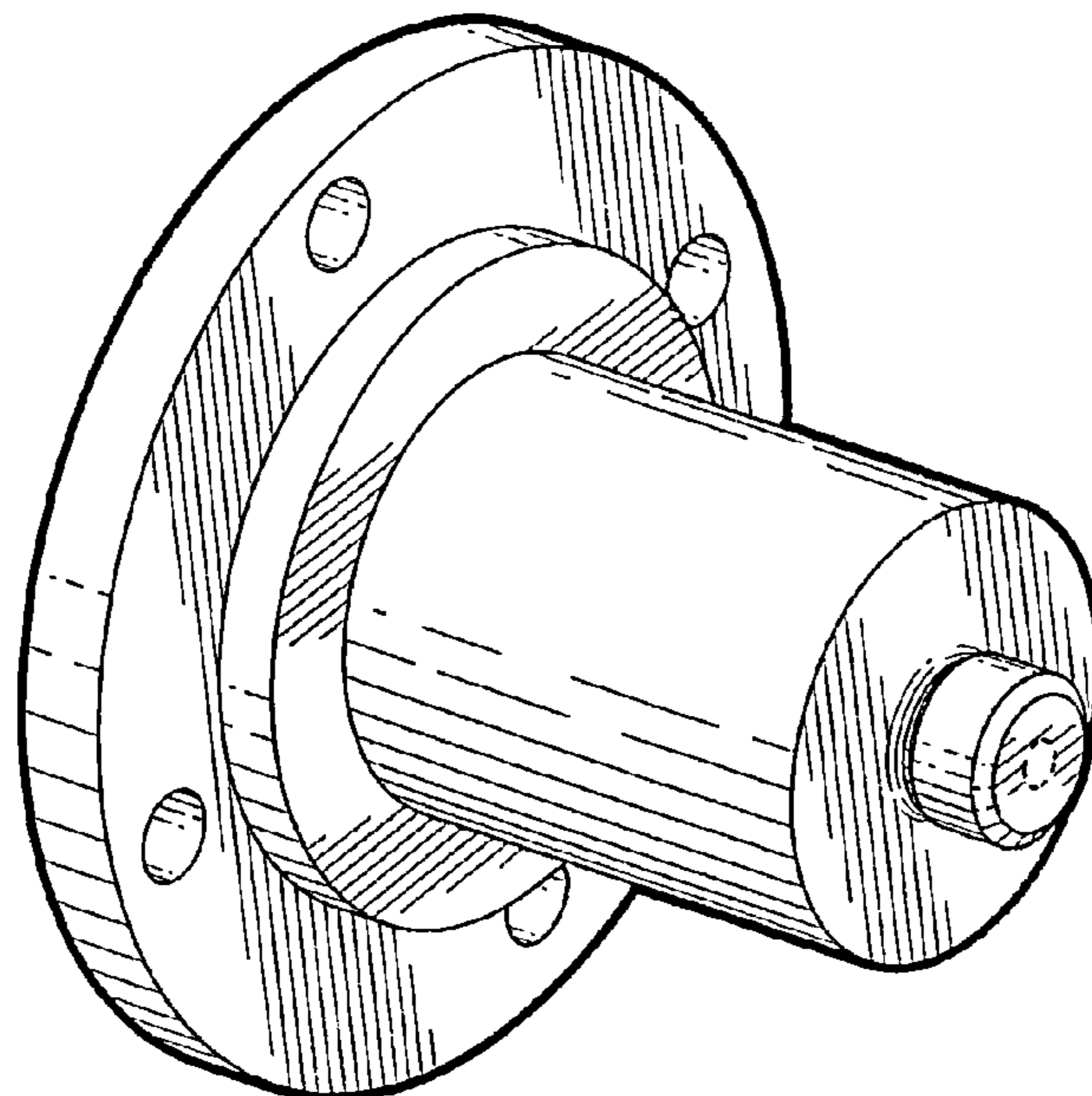

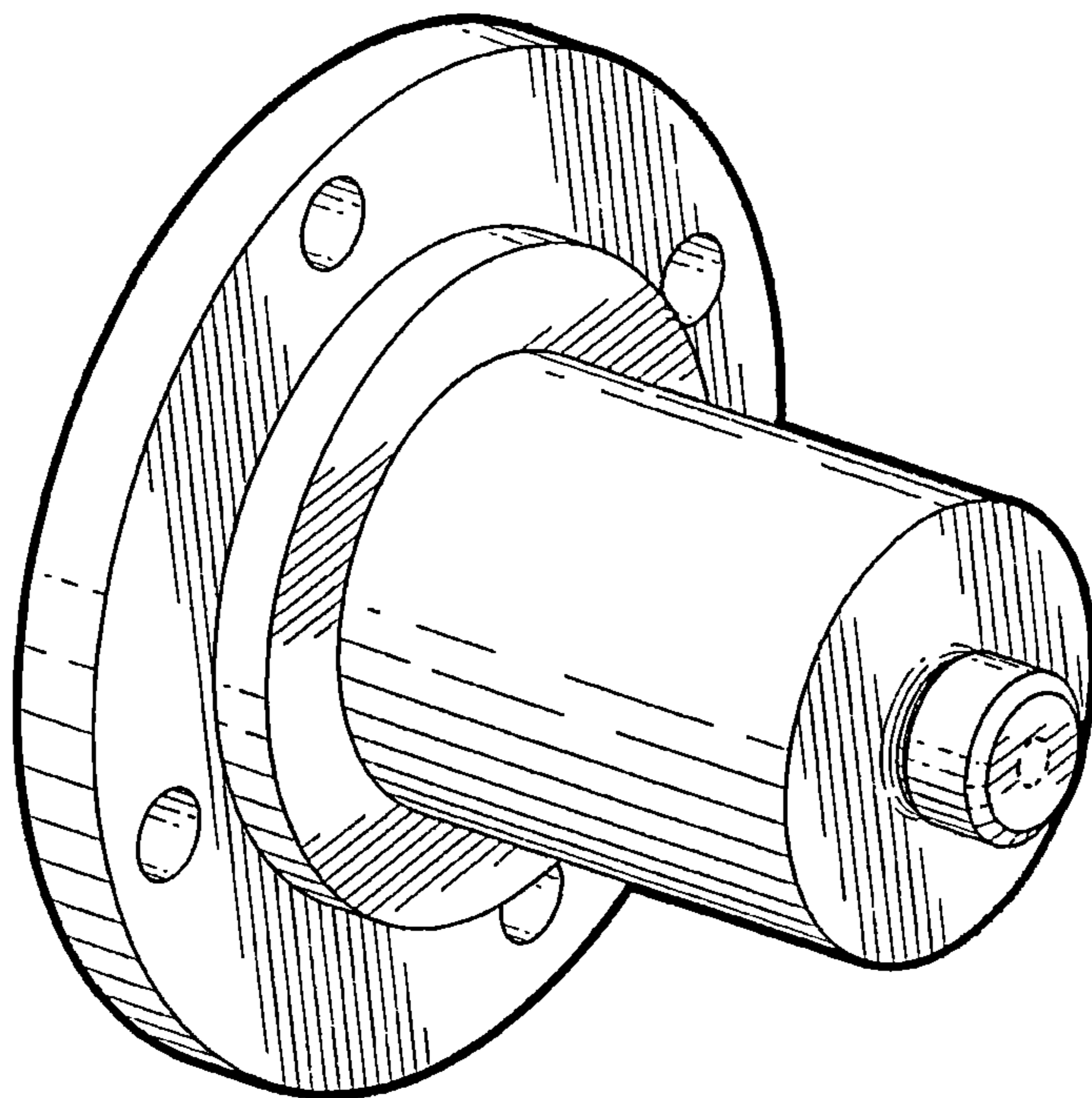

Fig. 1

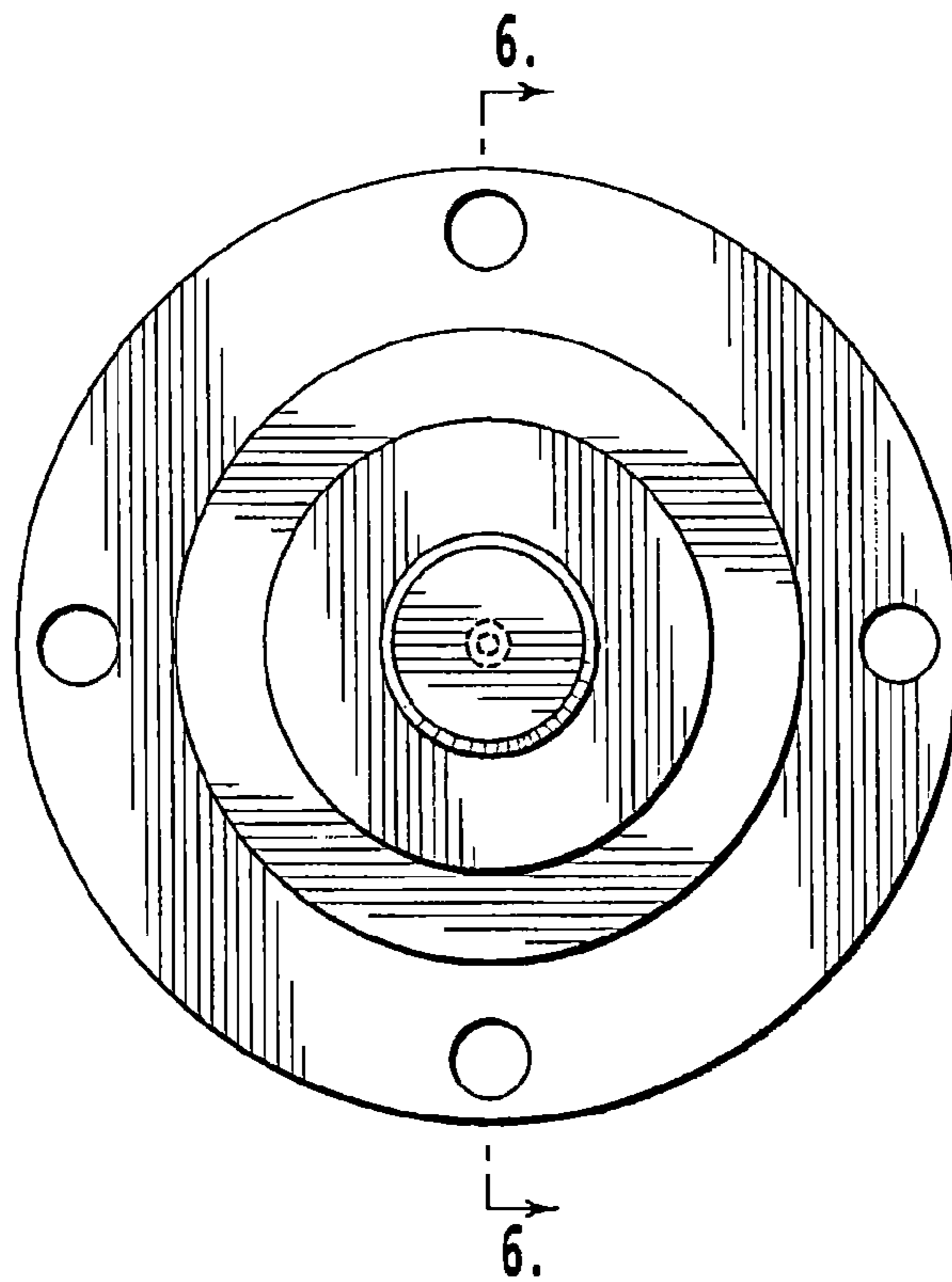

Fig. 2

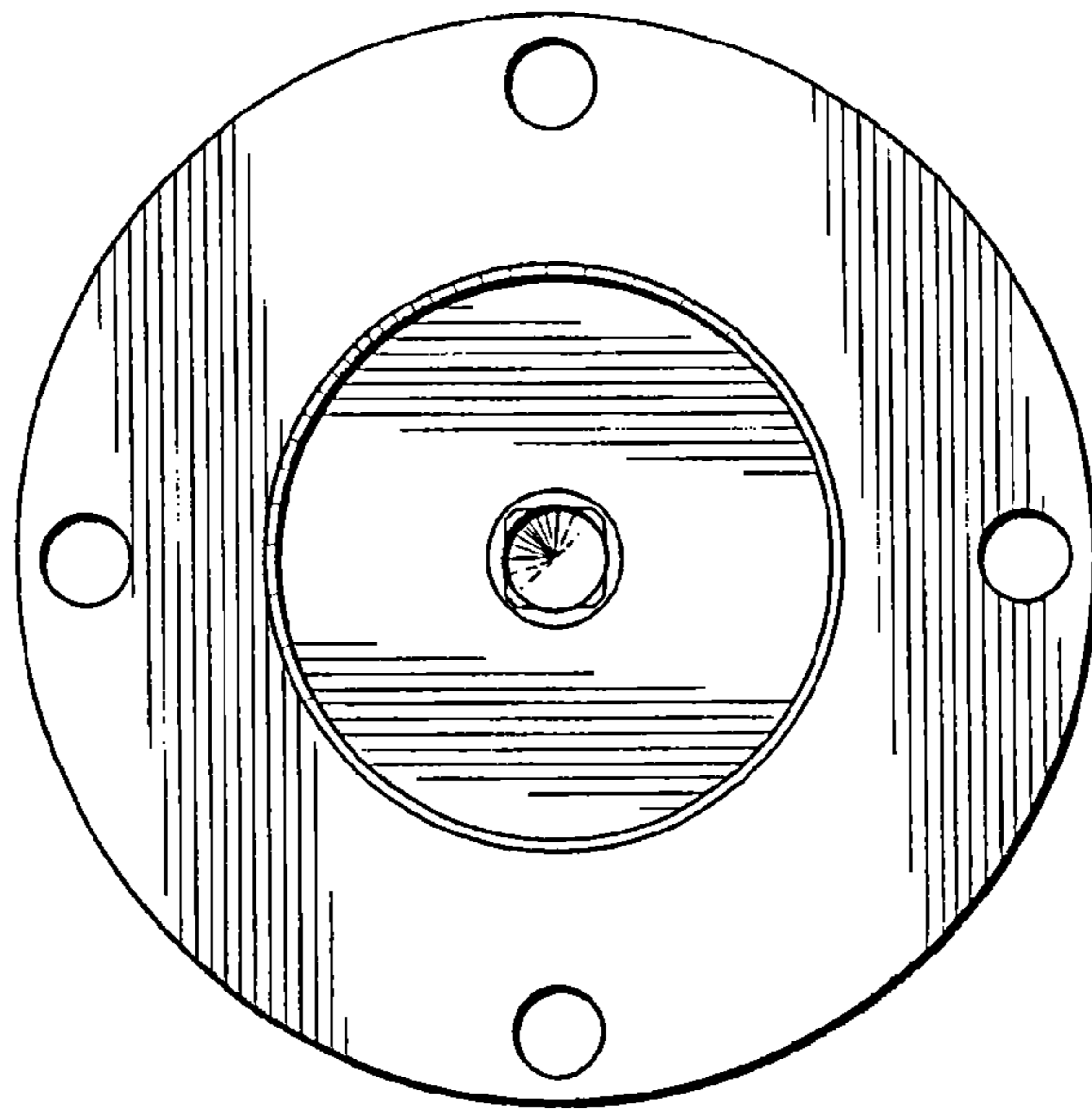

Fig.3

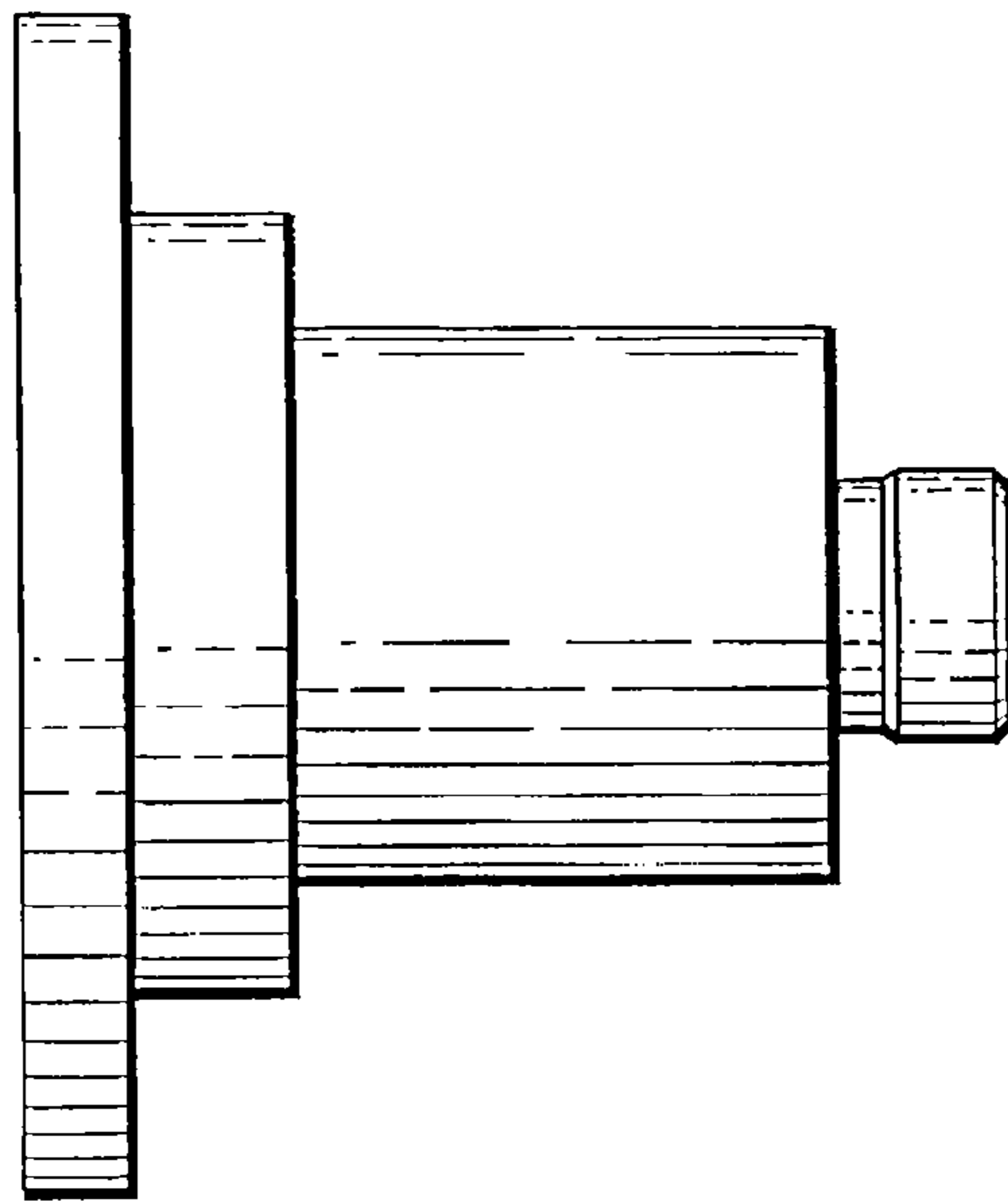

Fig. 4

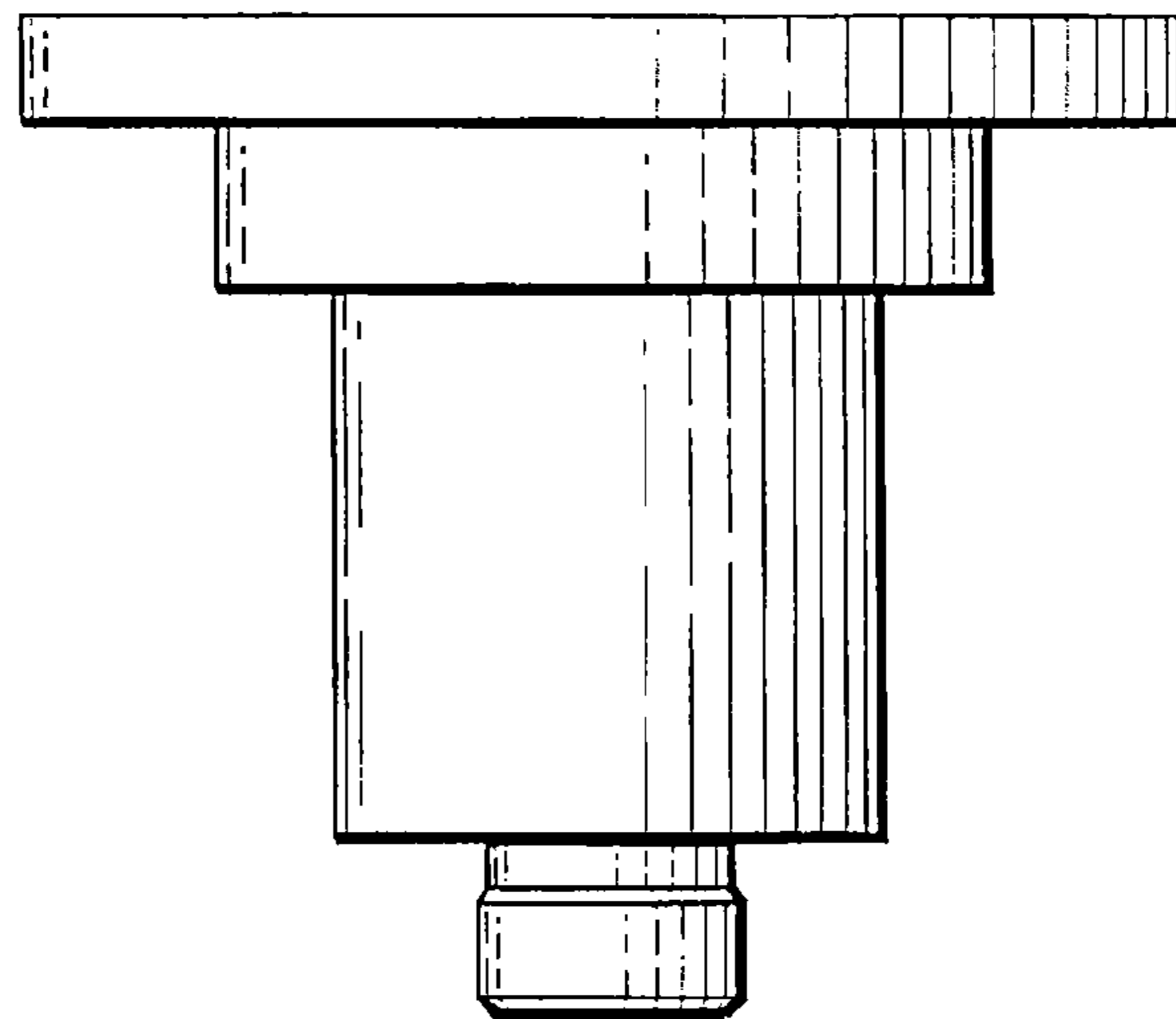

Fig.5

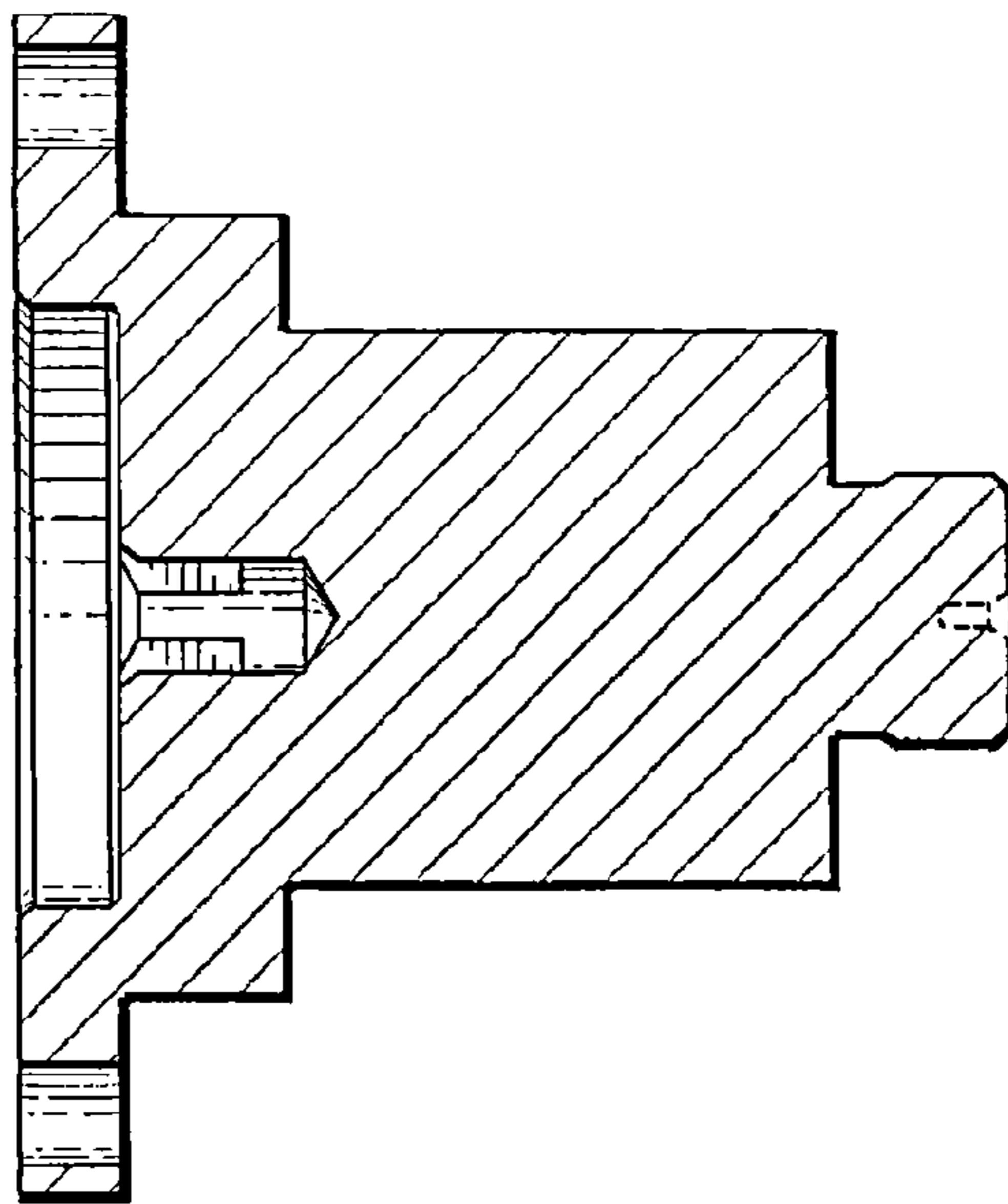

Fig. 6