



US00D714737S

(12) **United States Design Patent**
Imaizumi et al.

(10) **Patent No.:** **US D714,737 S**
(45) **Date of Patent:** **** Oct. 7, 2014**

(54) **ROTARY SOLENOID**

(75) Inventors: **Norihisa Imaizumi**, Gumma (JP);
Takeshi Kirihara, Gumma (JP); **Osamu Sekiguchi**, Gumma (JP); **Takaya Kato**, Gumma (JP); **Shoji Oiwa**, Gumma (JP)

(73) Assignee: **Nidec Servo Corporation**, Gumma (JP)

(**) Term: **14 Years**

(21) Appl. No.: **29/423,099**

(22) Filed: **May 29, 2012**

(30) **Foreign Application Priority Data**

Dec. 8, 2011 (JP) 2011-028477

(51) **LOC (10) Cl.** **13-03**

(52) **U.S. Cl.**
USPC **D13/166**

(58) **Field of Classification Search**
USPC D13/158, 166; 251/129.15; 335/126,
335/202, 206, 220, 272, 278; 361/160, 206
See application file for complete search history.

(56) **References Cited**

U.S. PATENT DOCUMENTS

D231,362 S *	4/1974	Doherty	D13/166
4,626,718 A *	12/1986	Moriyama	310/37
6,373,361 B1 *	4/2002	Umemoto et al.	335/220
6,611,186 B2 *	8/2003	Hanson et al.	335/220
7,078,992 B2 *	7/2006	Hasegawa et al.	335/220
7,701,314 B2 *	4/2010	Hazzard et al.	335/278
7,871,060 B2 *	1/2011	Armour	251/129.15
D658,593 S *	5/2012	Hsu et al.	D13/166
D676,393 S *	2/2013	Hsu	D13/166
D684,937 S *	6/2013	Hsu et al.	D13/166
2013/0249326 A1 *	9/2013	Kirihara et al.	310/38
2013/0342296 A1 *	12/2013	Li et al.	335/220

FOREIGN PATENT DOCUMENTS

JP 1047634 S 8/1999
JP D1047634/1 S 3/2000

OTHER PUBLICATIONS

Oki Micro Engineering Co., Ltd., "Swing Selector Reference Guide", KSA30H Series (Swing Selector), <http://www.oki-microeng.co.jp/product/pdf/11-ksa30h.pdf>.

Oki Micro Engineering Co., Ltd., "Swing Selector Reference Guide", KSA40F Series (Swing Selector), <http://www.oki-microeng.co.jp/product/pdf/12-ksa40f.pdf>.

* cited by examiner

Primary Examiner — Selina Sikder

(74) *Attorney, Agent, or Firm* — Keating & Bennett, LLP

(57) **CLAIM**

The ornamental design for a rotary solenoid, as shown and described.

DESCRIPTION

FIG. 1 is a front elevation view of rotary solenoid according to our principal new design;
FIG. 2 is a rear elevation view thereof;
FIG. 3 is a right side elevation view thereof;
FIG. 4 is a left side elevation view thereof;
FIG. 5 is a top plan view thereof;
FIG. 6 is a bottom plan view thereof;
FIG. 7 is a front perspective view thereof;
FIG. 8 is a rear perspective view thereof;
FIG. 9 is a front elevation view of a rotary solenoid according to our second related new design;
FIG. 10 is a rear elevation view thereof;
FIG. 11 is a right side elevation view thereof;
FIG. 12 is a left side elevation view thereof;
FIG. 13 is a top plan view thereof;
FIG. 14 is a bottom plan view thereof; and,
FIG. 15 is a perspective view thereof.

1 Claim, 15 Drawing Sheets

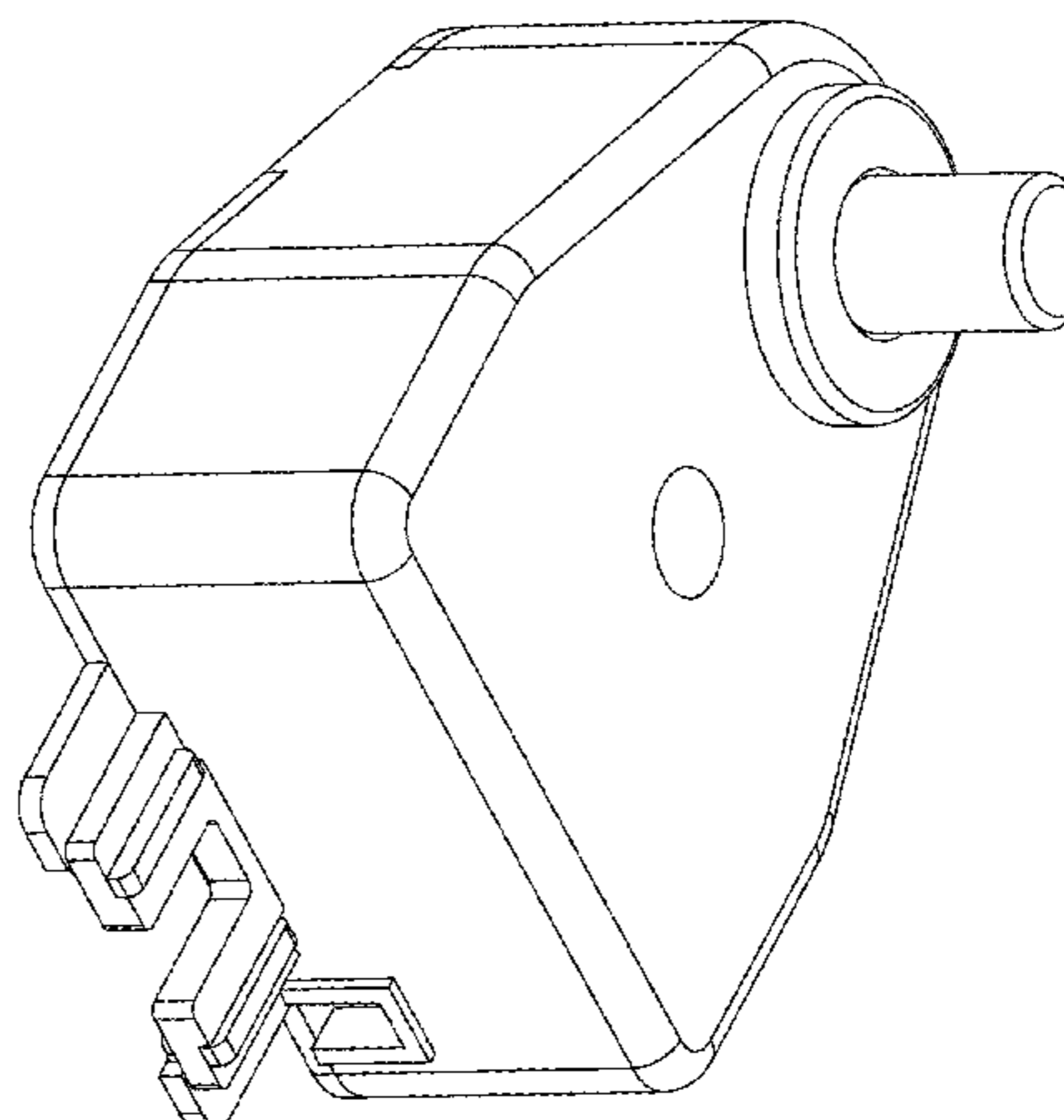
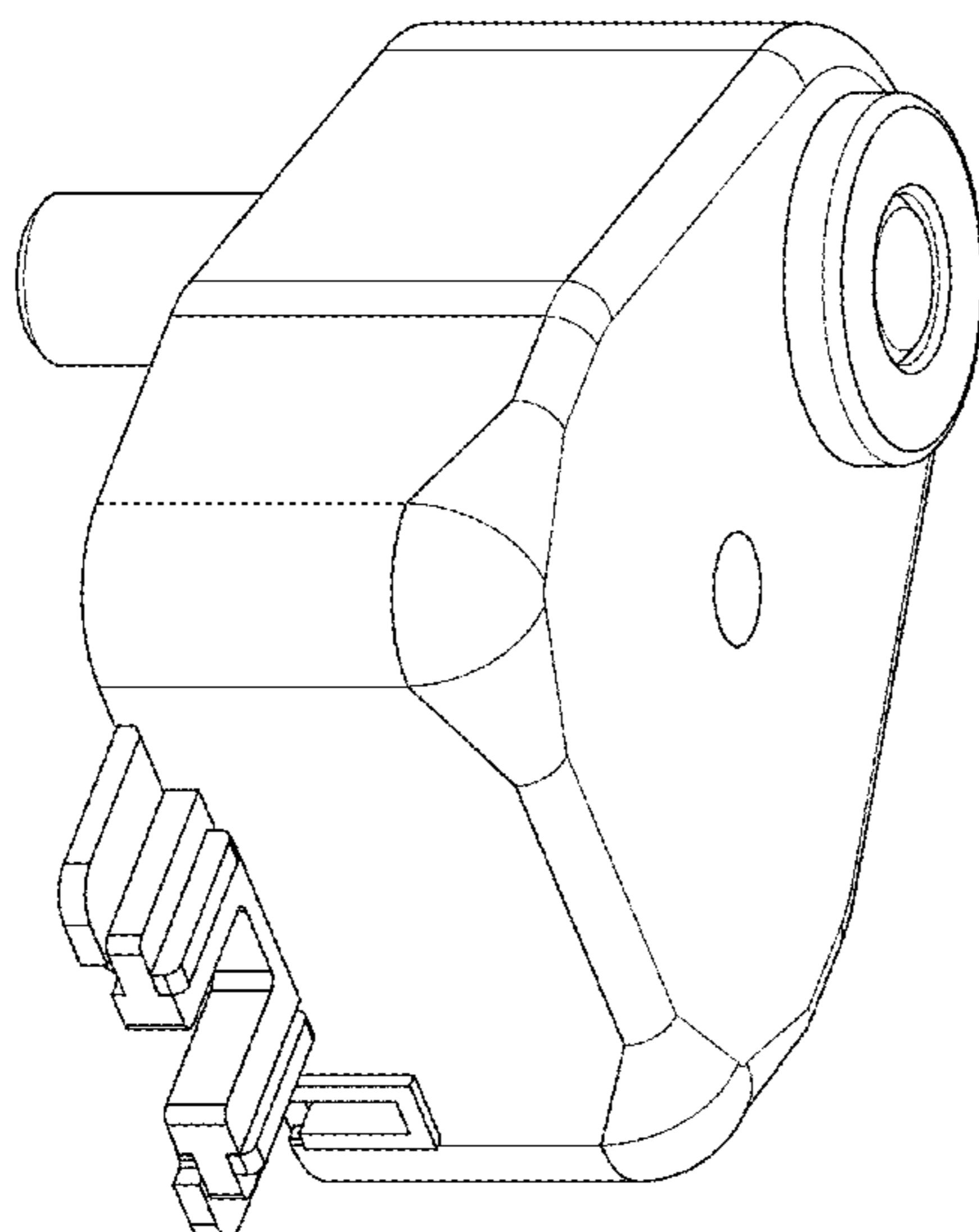

FIG. 1

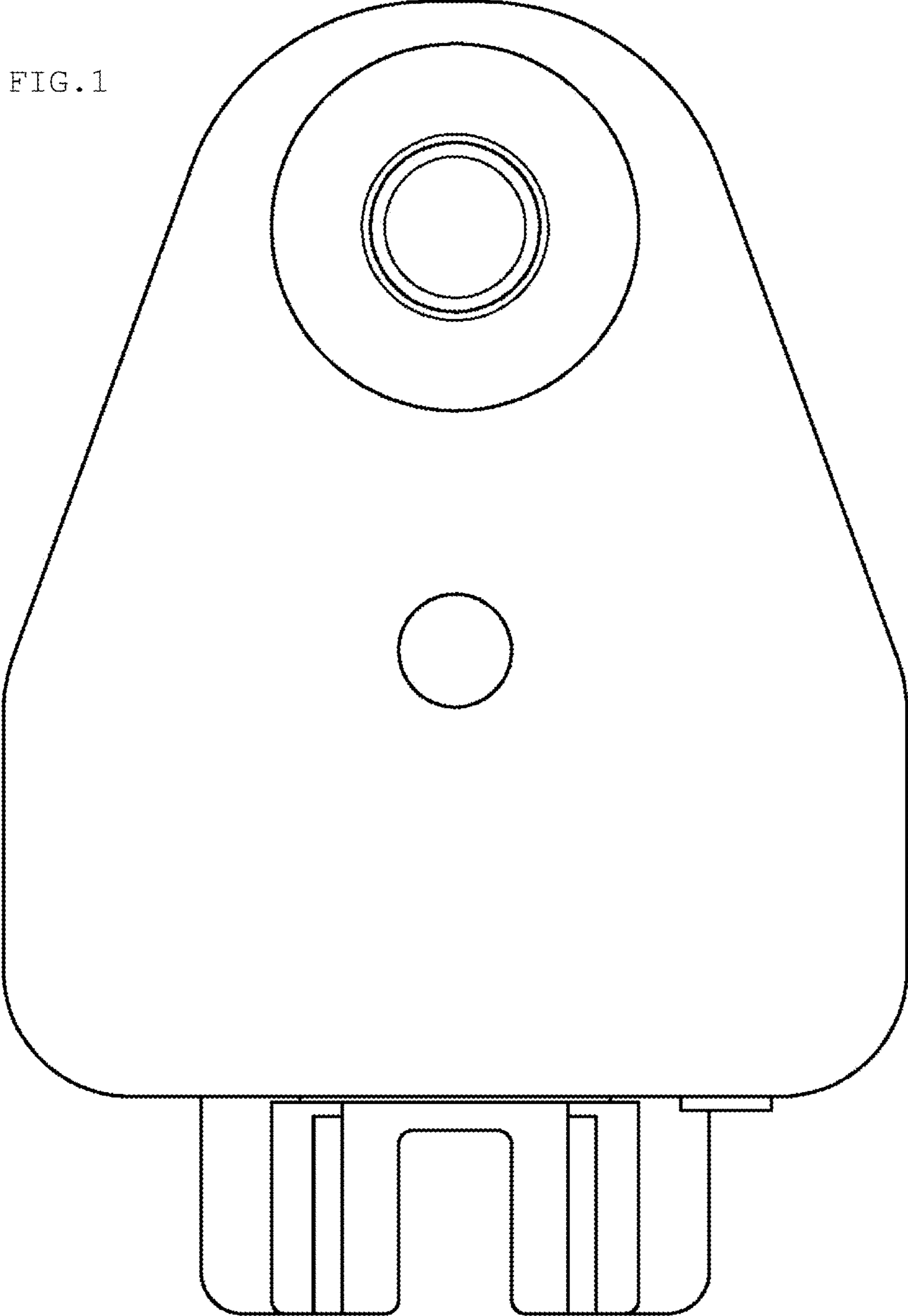
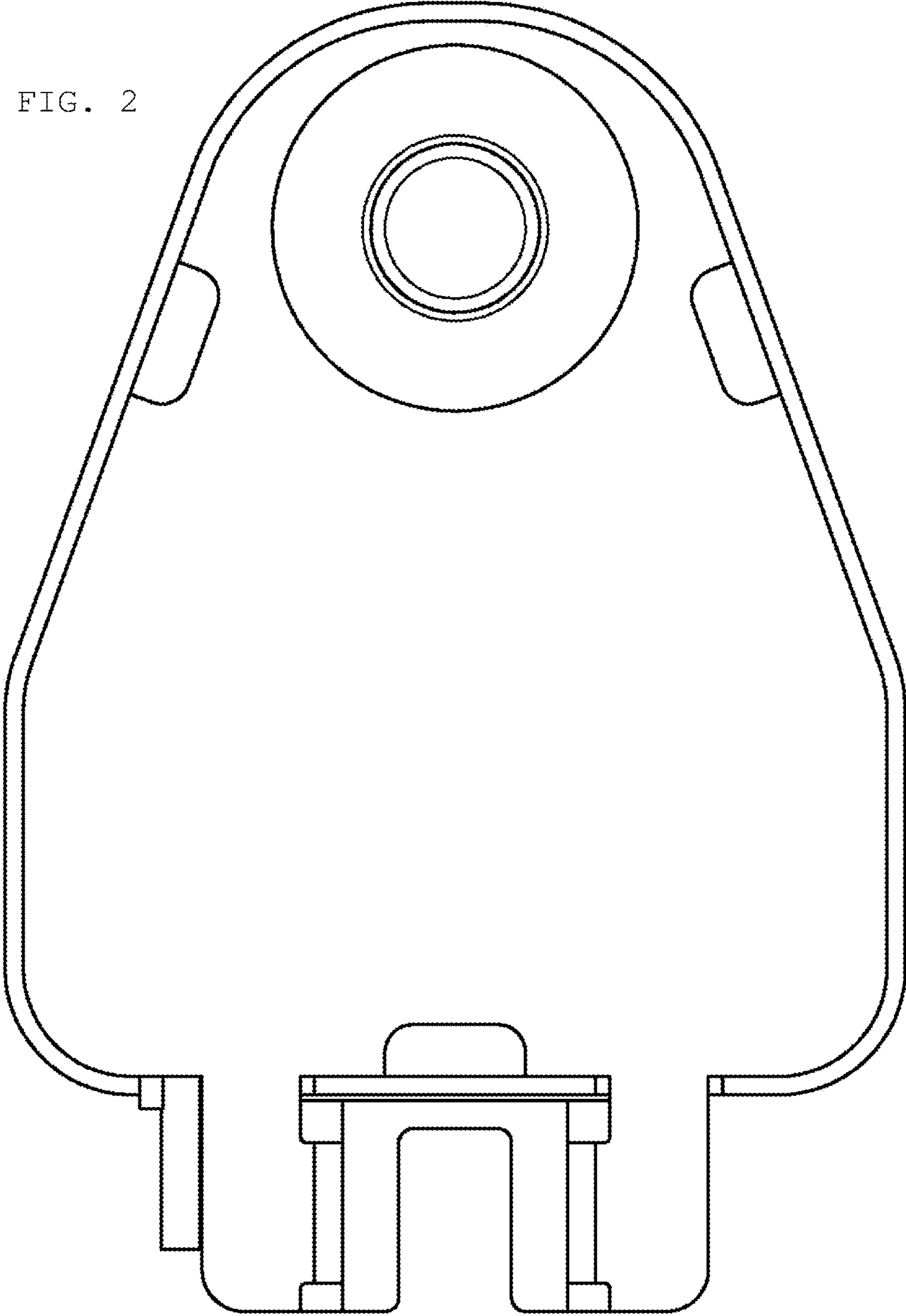

FIG. 2



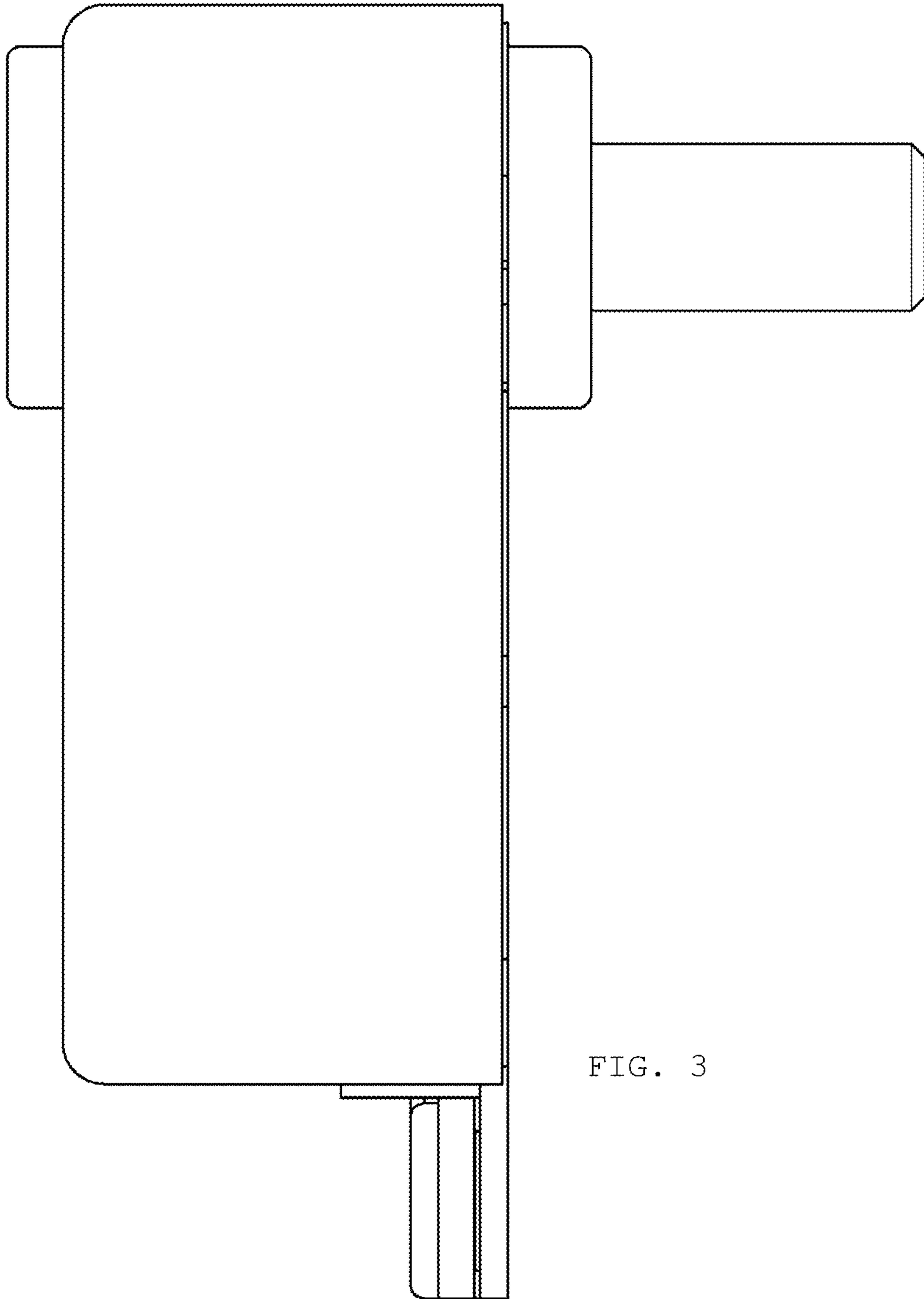

FIG. 3

FIG. 4

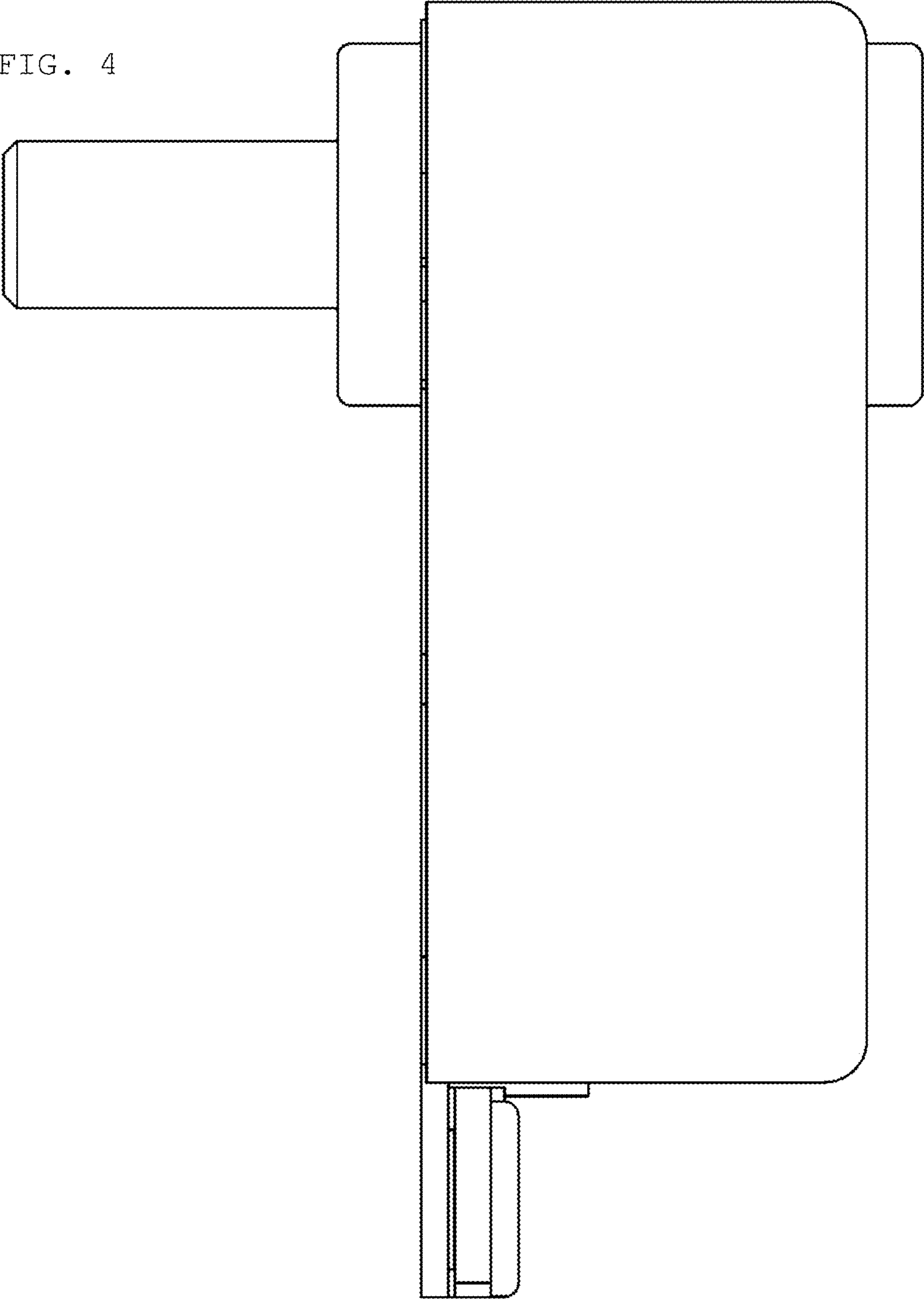

FIG. 5

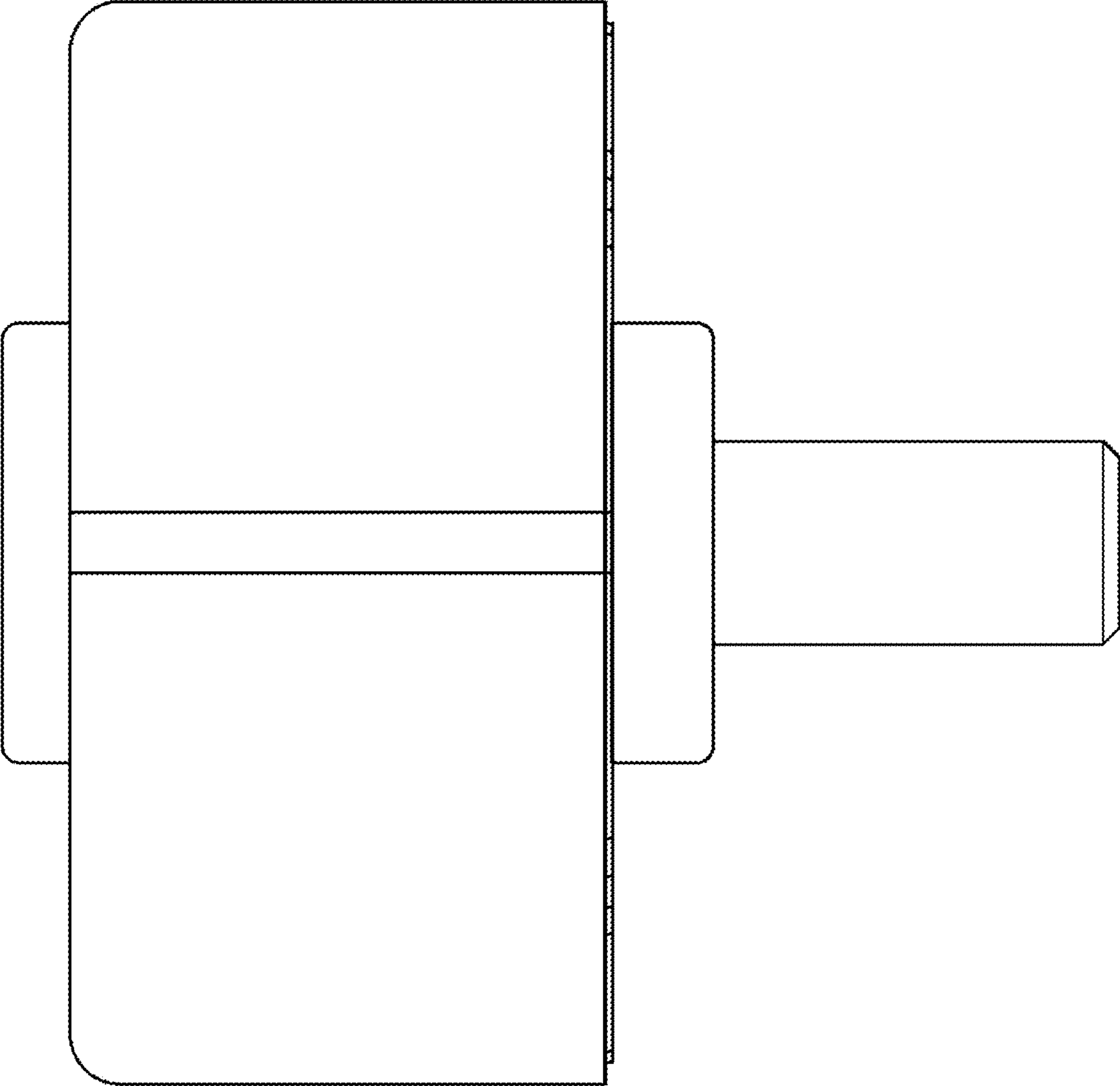

FIG. 6

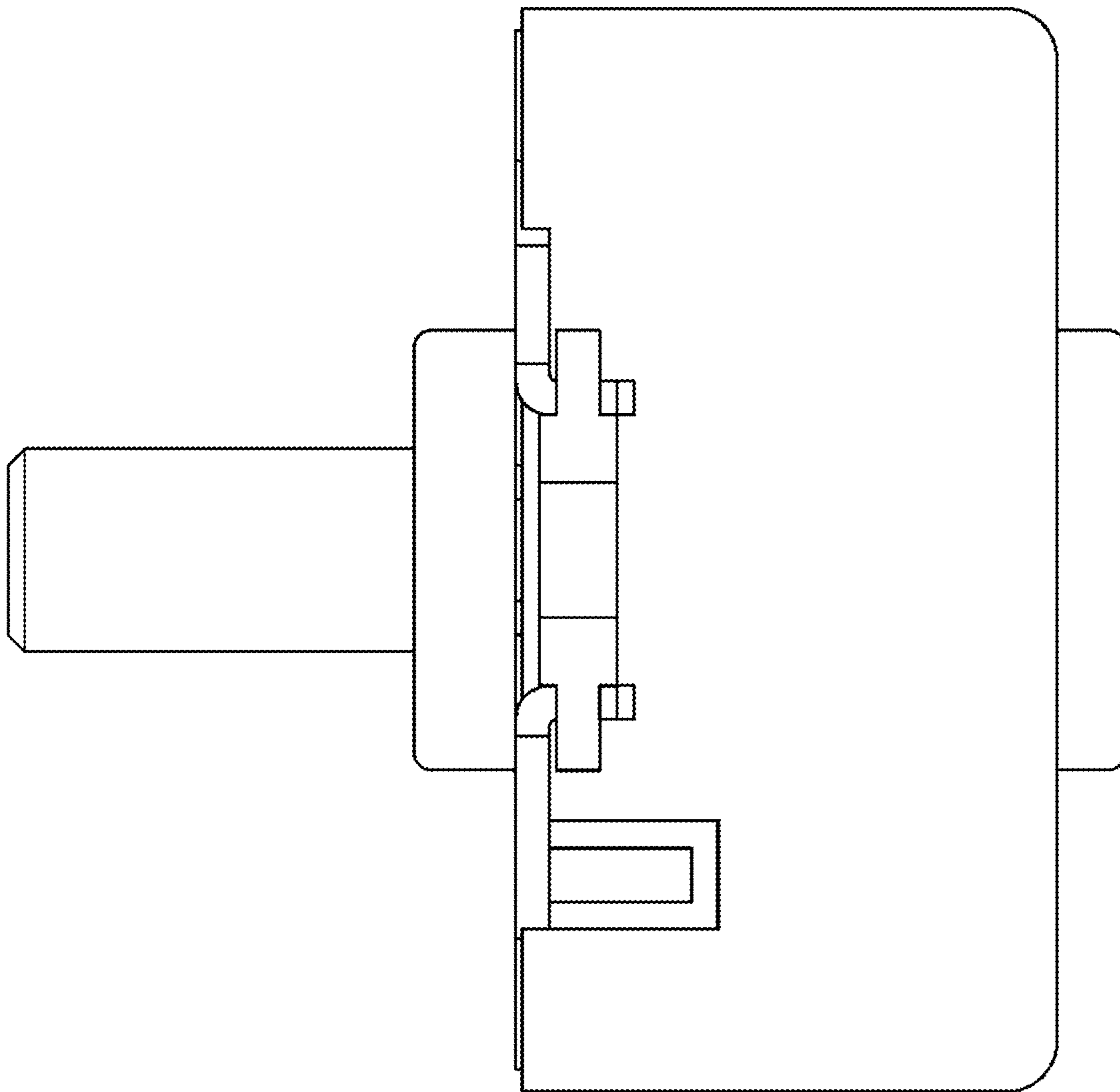

FIG. 7

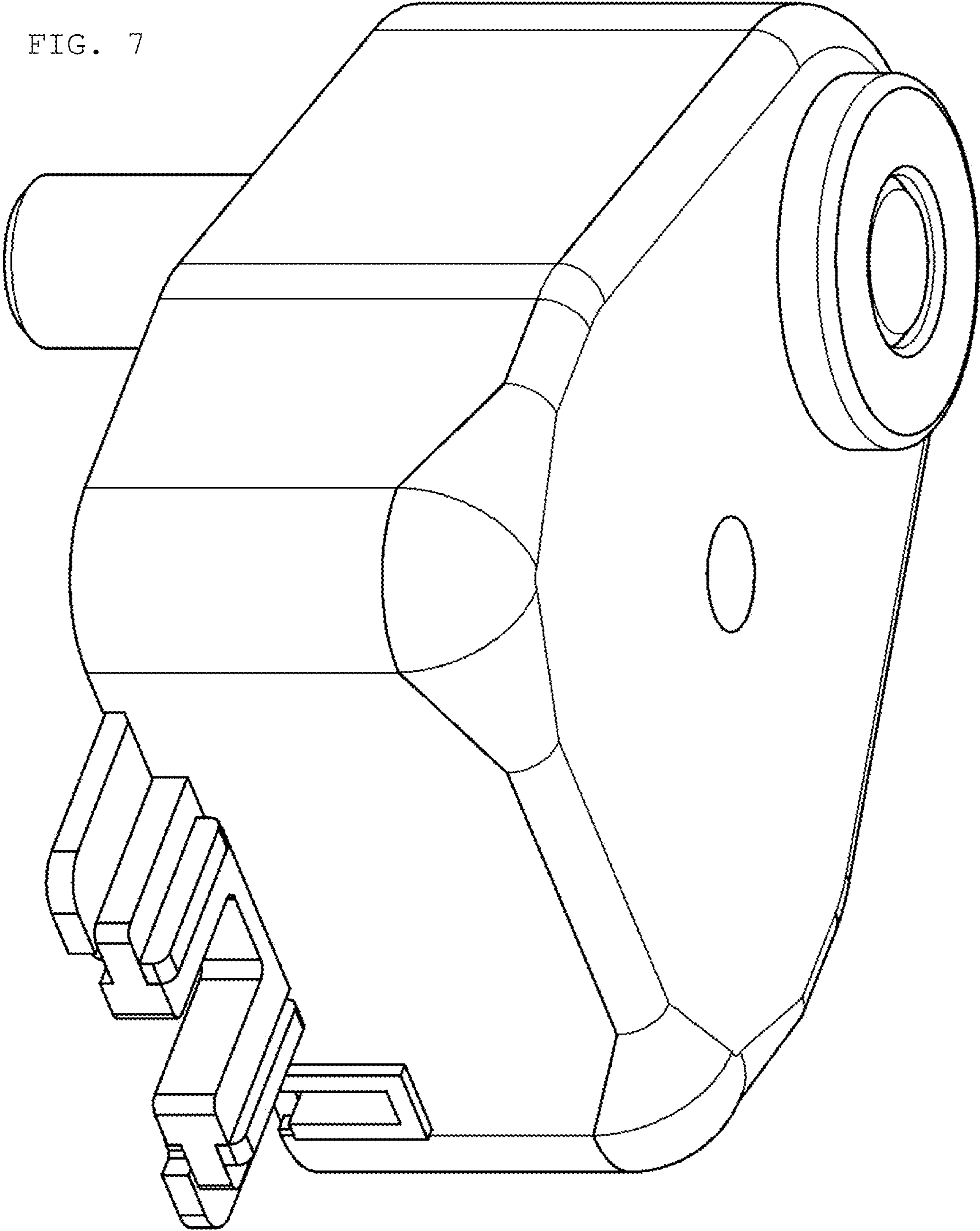

FIG. 8

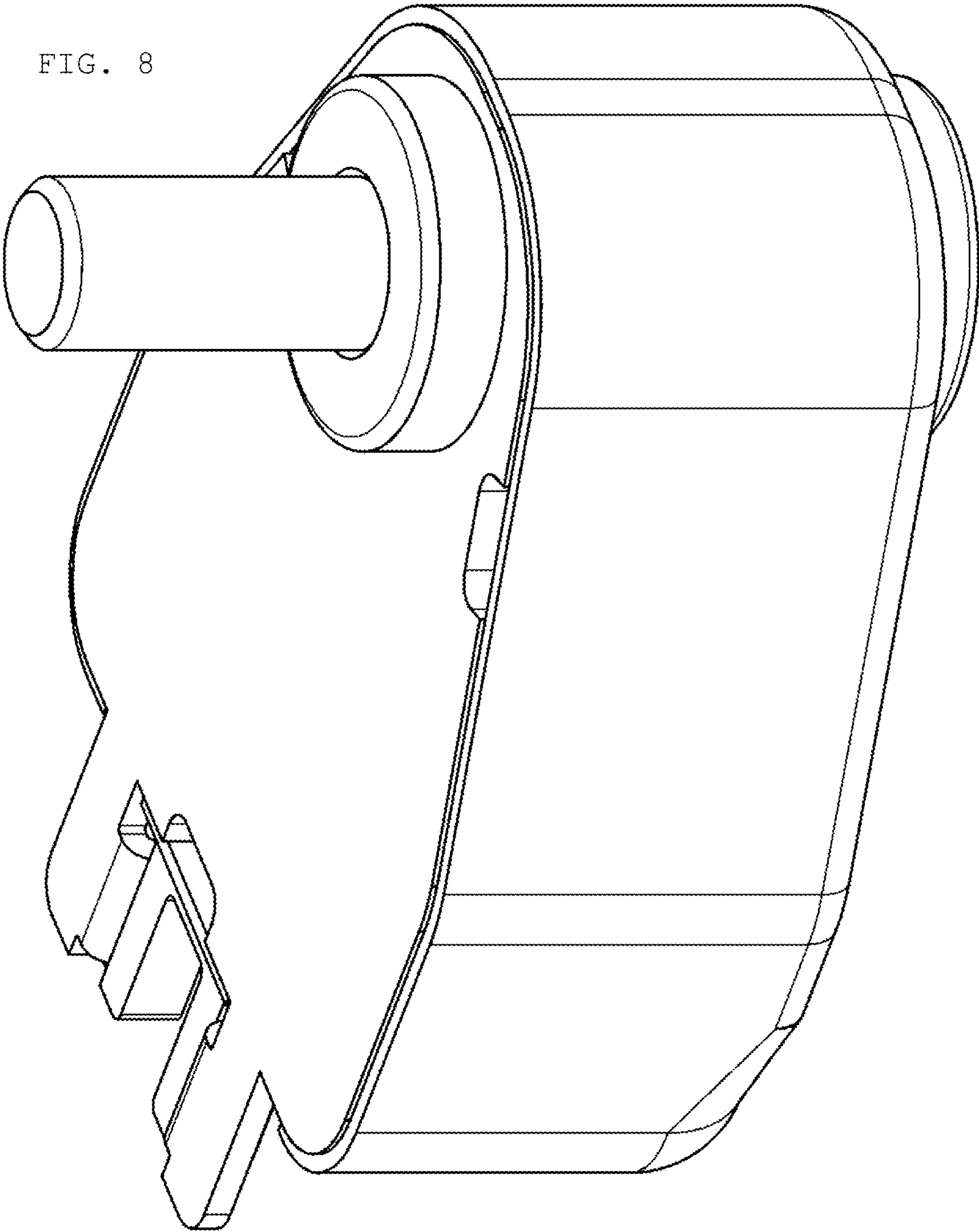

FIG. 9

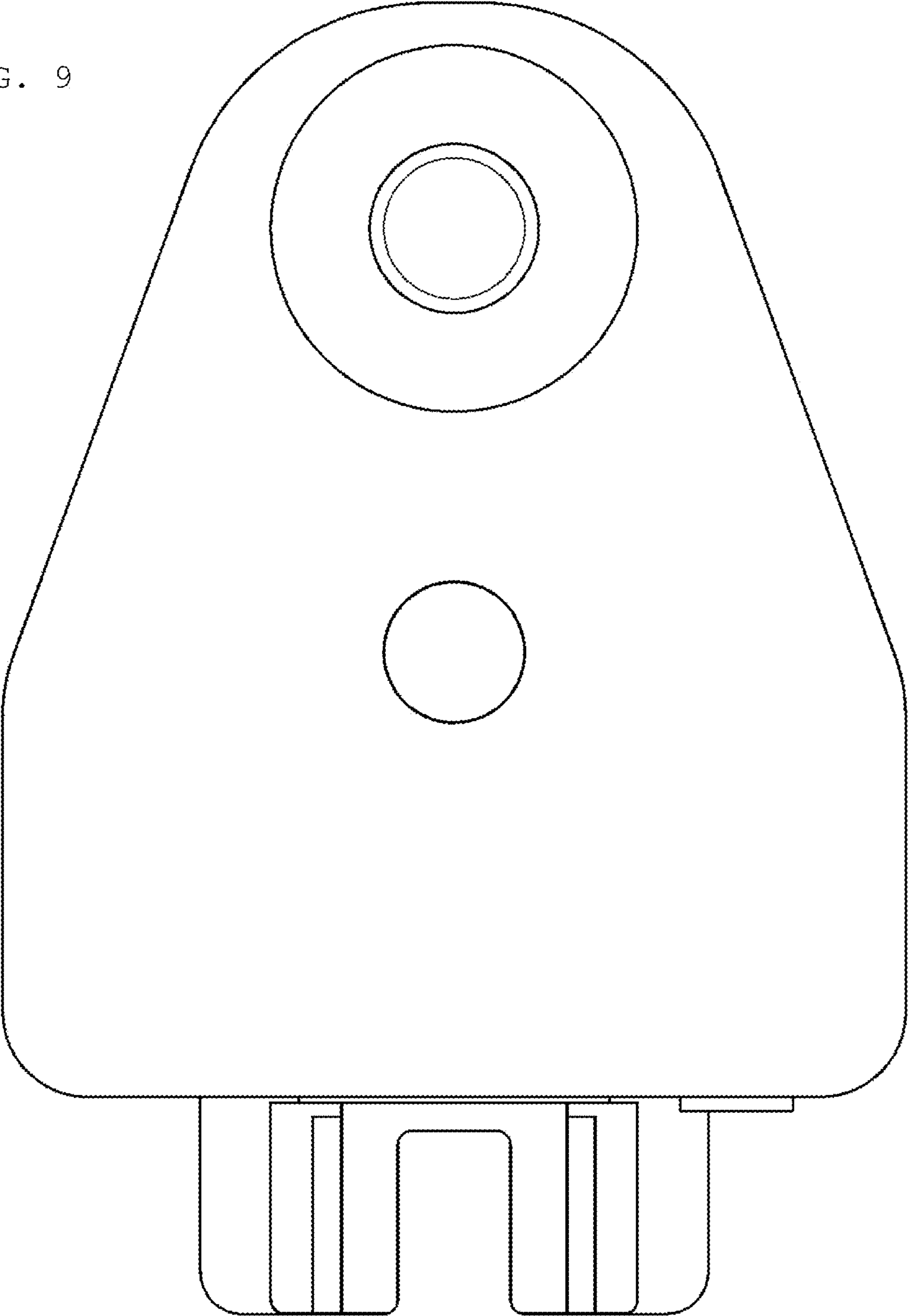

FIG. 10

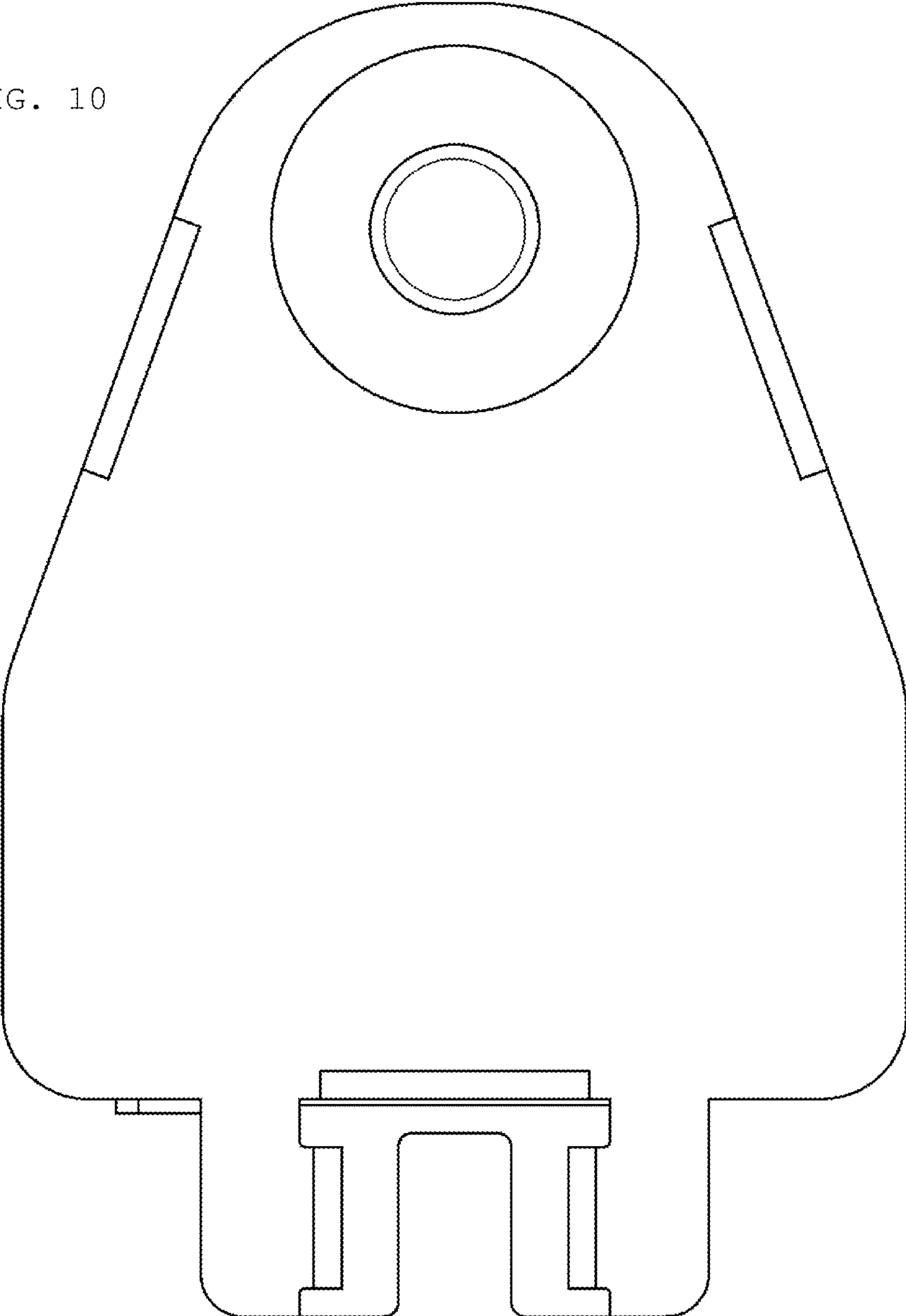
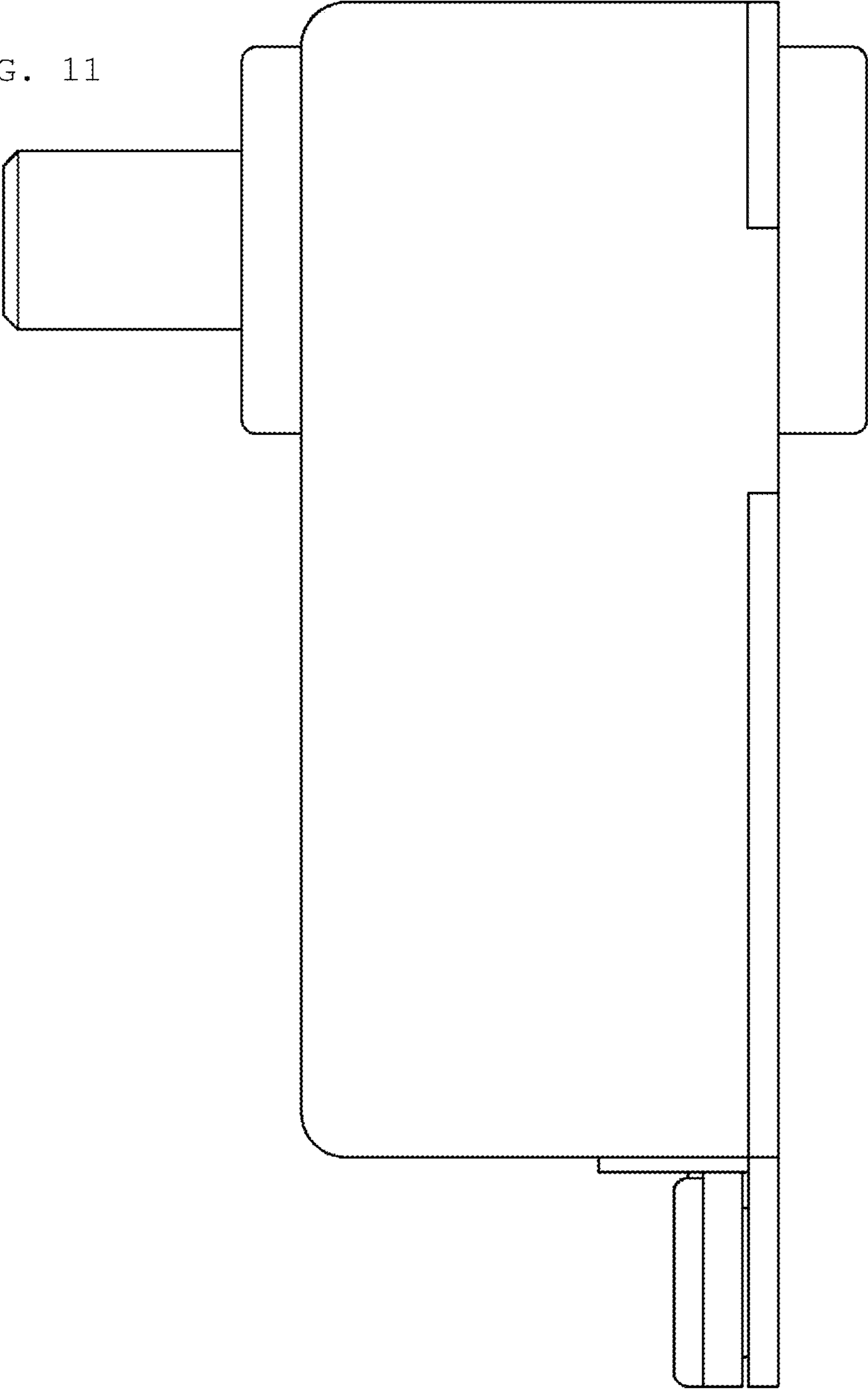

FIG. 11



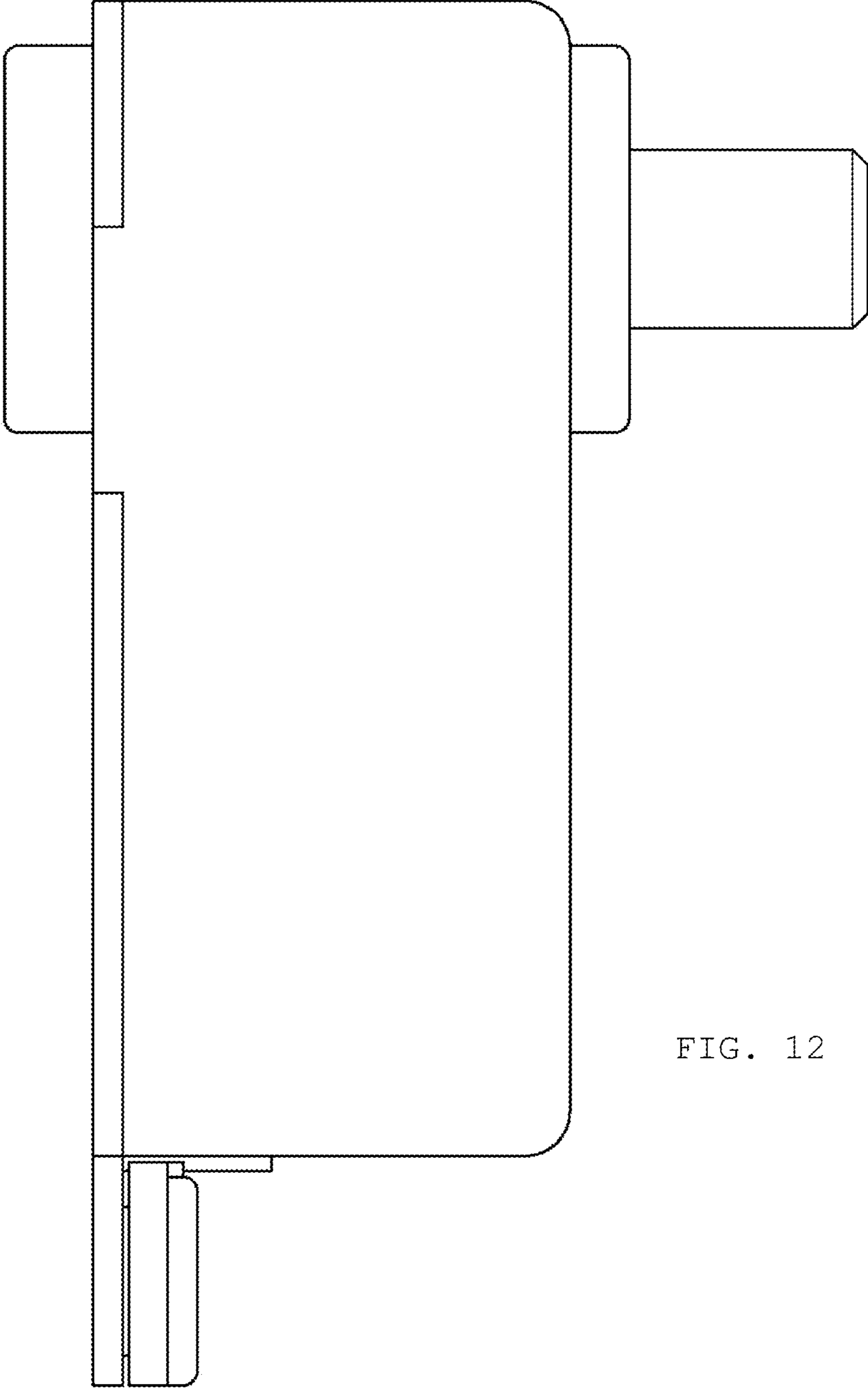
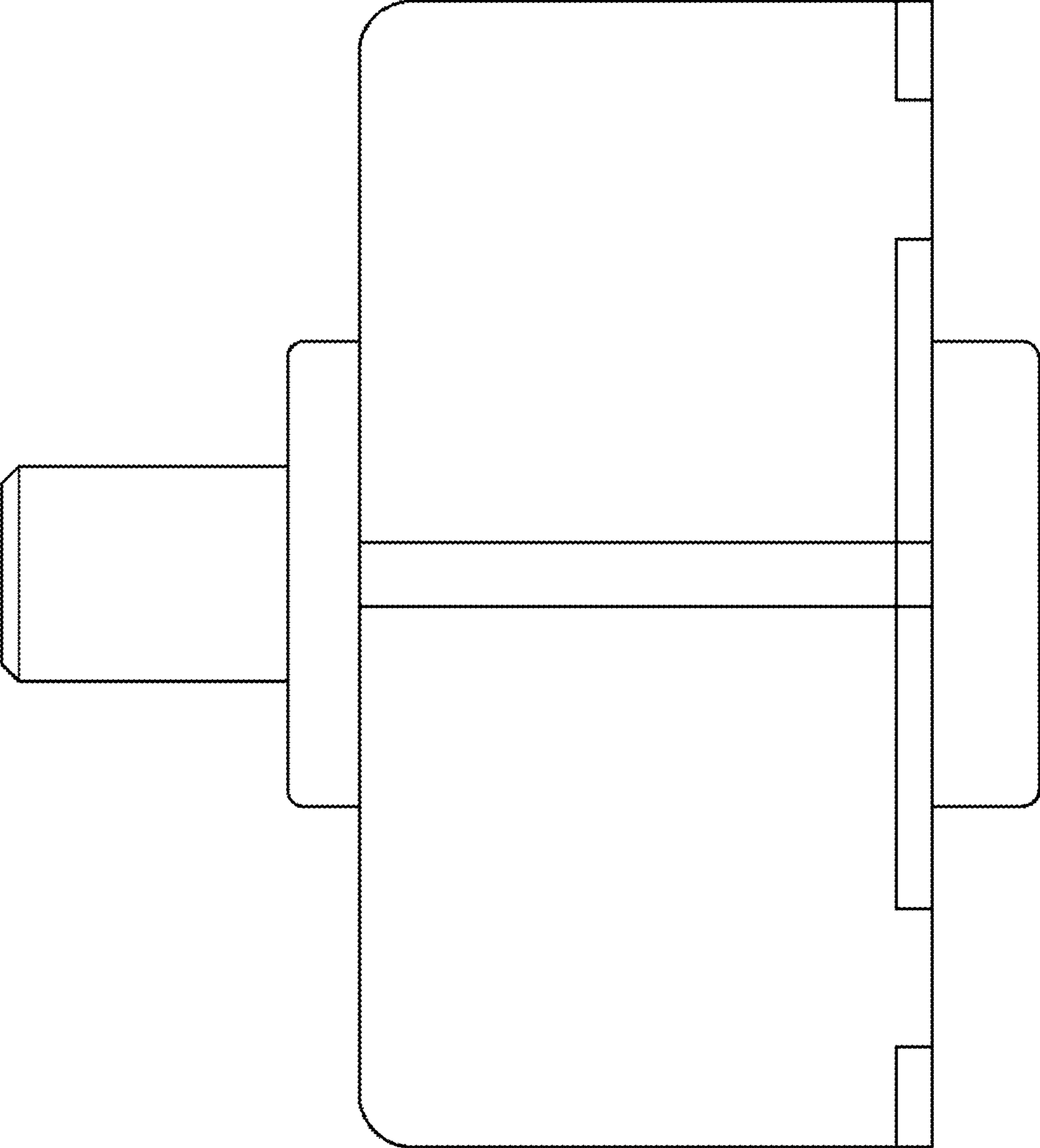

FIG. 12

FIG. 13



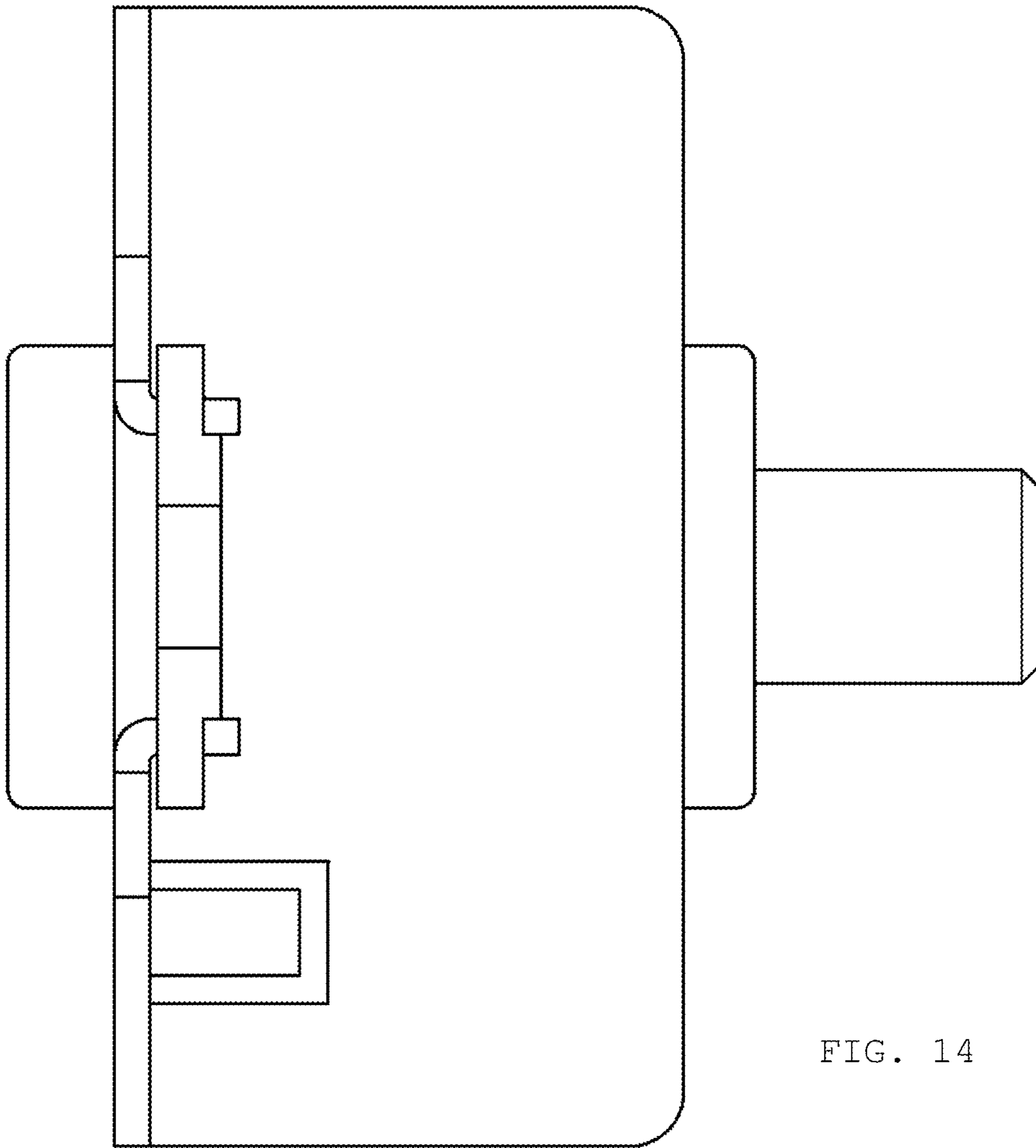

FIG. 14

FIG. 15

