



US00D714354S

(12) **United States Design Patent**  
**Talbot**

(10) **Patent No.:** **US D714,354 S**  
(45) **Date of Patent:** **\*\* Sep. 30, 2014**

- (54) **HOLD DOWN FOR A BLADE OF A SICKLE**
- (71) Applicant: **MacDon Industries Ltd.**, Winnipeg (CA)
- (72) Inventor: **Francois R. Talbot**, Winnipeg (CA)
- (73) Assignee: **MacDon Industries Ltd.**, Winnipeg MB (CA)
- (\*\*) Term: **14 Years**
- (21) Appl. No.: **29/477,344**
- (22) Filed: **Dec. 20, 2013**
- (51) **LOC (10) Cl.** ..... **15-03**
- (52) **U.S. Cl.**  
USPC ..... **D15/28**
- (58) **Field of Classification Search**  
USPC ..... D15/11, 17, 28, 29, 32; 56/298, 310, 56/307, 305  
See application file for complete search history.

(56) **References Cited**

**U.S. PATENT DOCUMENTS**

|           |     |         |                 |        |
|-----------|-----|---------|-----------------|--------|
| 413,116   | A * | 10/1889 | Walker          | 56/311 |
| D44,224   | S * | 6/1913  | Suhr            | D15/28 |
| 1,728,326 | A * | 9/1929  | Borkhuis        | 56/311 |
| 2,431,663 | A * | 11/1947 | Scranton        | 56/307 |
| 2,484,630 | A * | 10/1949 | Magee           | 56/309 |
| 2,619,787 | A * | 12/1952 | Mills et al.    | 56/310 |
| 2,654,987 | A * | 10/1953 | Mills et al.    | 56/310 |
| D197,903  | S * | 4/1964  | Scarnato et al. | D15/28 |
| 3,146,570 | A * | 9/1964  | Otten           | 56/311 |
| 3,171,242 | A * | 3/1965  | Scarnato et al. | 56/310 |
| 3,401,512 | A * | 9/1968  | Pool et al.     | 56/298 |
| 3,553,948 | A * | 1/1971  | White           | 56/307 |
| 3,566,592 | A * | 3/1971  | Jerman et al.   | 56/311 |
| D225,356  | S * | 12/1972 | Neal et al.     | D15/28 |
| 3,978,645 | A * | 9/1976  | Bennett et al.  | 56/310 |
| D254,548  | S * | 3/1980  | Dowd et al.     | D15/28 |

|              |      |         |                    |          |
|--------------|------|---------|--------------------|----------|
| 4,290,326    | A *  | 9/1981  | Ibach et al.       | 76/101.1 |
| 4,519,192    | A *  | 5/1985  | Oppenhuisen et al. | 56/298   |
| 4,644,738    | A *  | 2/1987  | Krambeck et al.    | 56/259   |
| 4,651,511    | A *  | 3/1987  | Majkrzak           | 56/310   |
| 4,909,026    | A *  | 3/1990  | Molzahn et al.     | 56/298   |
| 5,123,237    | A *  | 6/1992  | Lutz               | 56/298   |
| 5,209,053    | A *  | 5/1993  | Verbeek            | 56/298   |
| 5,241,811    | A *  | 9/1993  | Bolinger           | 56/310   |
| 5,343,682    | A *  | 9/1994  | Puncochar          | 56/305   |
| 5,884,465    | A *  | 3/1999  | Ibach et al.       | 56/298   |
| 5,979,152    | A *  | 11/1999 | McCredie           | 56/298   |
| 6,305,154    | B1 * | 10/2001 | Yang et al.        | 56/298   |
| 6,510,681    | B2 * | 1/2003  | Yang et al.        | 56/298   |
| 6,543,211    | B1 * | 4/2003  | Talbot             | 56/296   |
| D494,605     | S *  | 8/2004  | Calmer             | D15/28   |
| 6,962,040    | B2 * | 11/2005 | Talbot             | 56/297   |
| 7,328,565    | B2 * | 2/2008  | Snider et al.      | 56/298   |
| 7,373,769    | B2 * | 5/2008  | Talbot et al.      | 56/303   |
| 7,464,527    | B2 * | 12/2008 | Blakeslee et al.   | 56/298   |
| D623,671     | S *  | 9/2010  | Bolyard            | D15/32   |
| 7,870,713    | B2 * | 1/2011  | Schroeder          | 56/298   |
| 2002/0005035 | A1 * | 1/2002  | Hovsepian          | 56/298   |

(Continued)

*Primary Examiner* — Mark Goodwin

(74) *Attorney, Agent, or Firm* — Adrian D. Battison; Ade & Company Inc.

(57) **CLAIM**

The ornamental design for a hold down for a blade of a sickle, as shown and described.

**DESCRIPTION**

FIG. 1 is a top, side, isometric view of a hold down for a blade of a sickle showing my new design.  
 FIG. 2 is a top plan view thereof.  
 FIG. 3 is a rear elevational view thereof.  
 FIG. 4 is a front elevational view thereof.  
 FIG. 5 is a bottom plan view thereof.  
 FIG. 6 is a first side elevational view thereof; and,  
 FIG. 7 is a second side elevational view thereof.

**1 Claim, 4 Drawing Sheets**

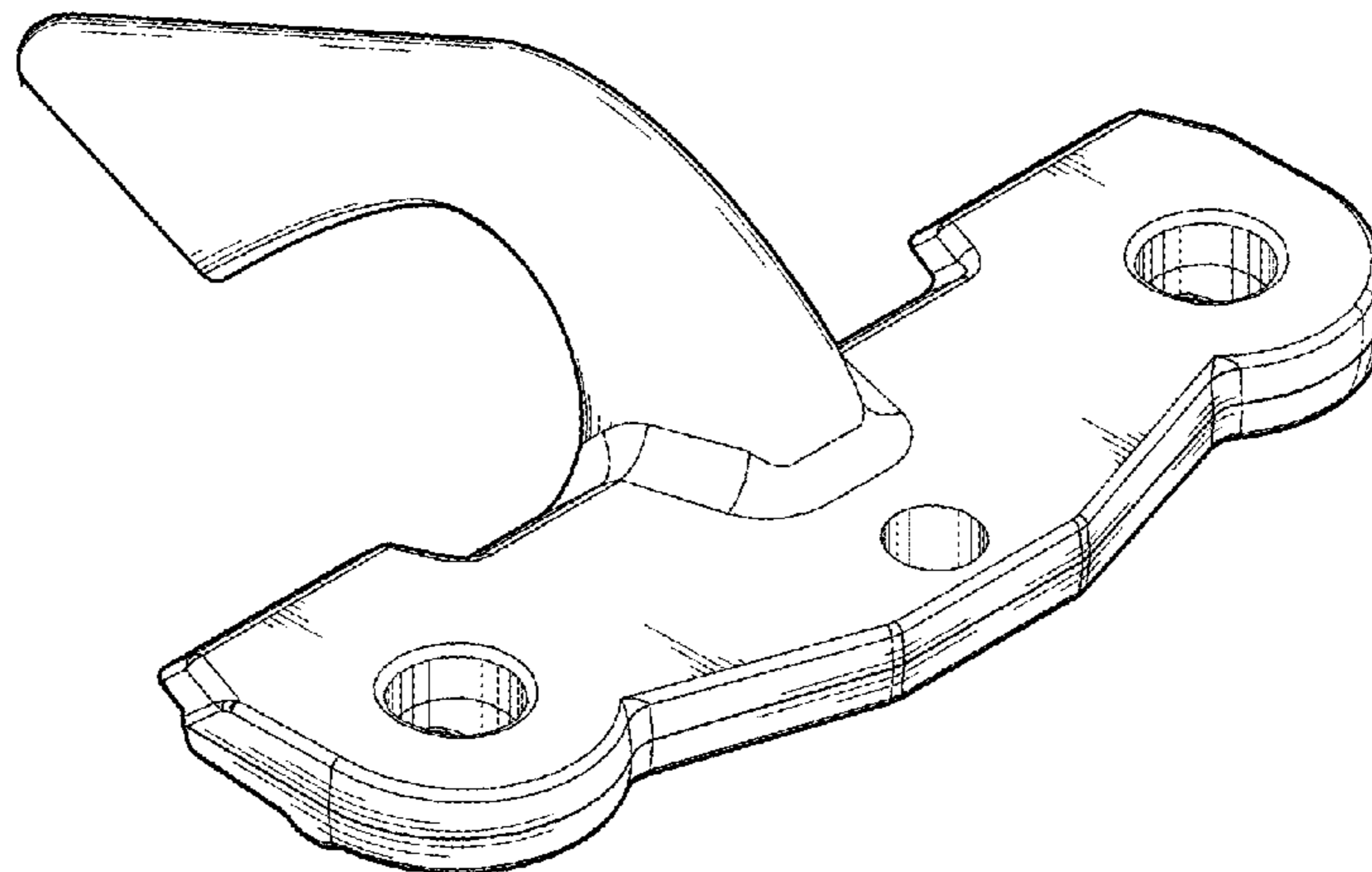

# US D714,354 S

Page 2

---

(56)

## References Cited

### U.S. PATENT DOCUMENTS

|                  |        |                    |         |
|------------------|--------|--------------------|---------|
| 2005/0016151 A1* | 1/2005 | Lolley .....       | 56/307  |
| 2008/0006016 A1* | 1/2008 | Snider et al. .... | 56/297  |
| 2009/0199529 A1* | 8/2009 | Schroeder .....    | 56/12.9 |
| 2003/0074875 A1* | 4/2003 | Talbot .....       | 56/257  |

\* cited by examiner

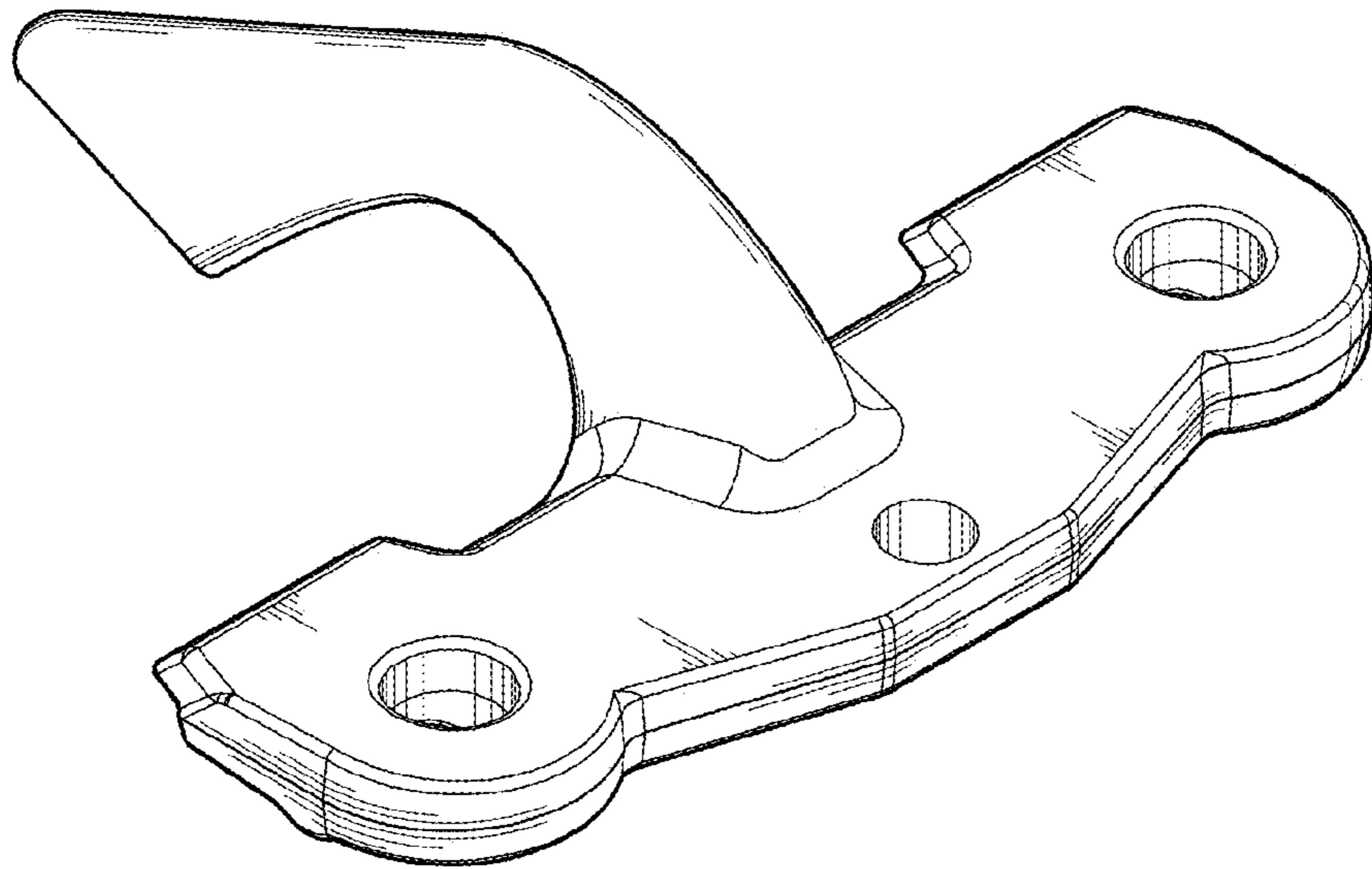

**FIG. 1**

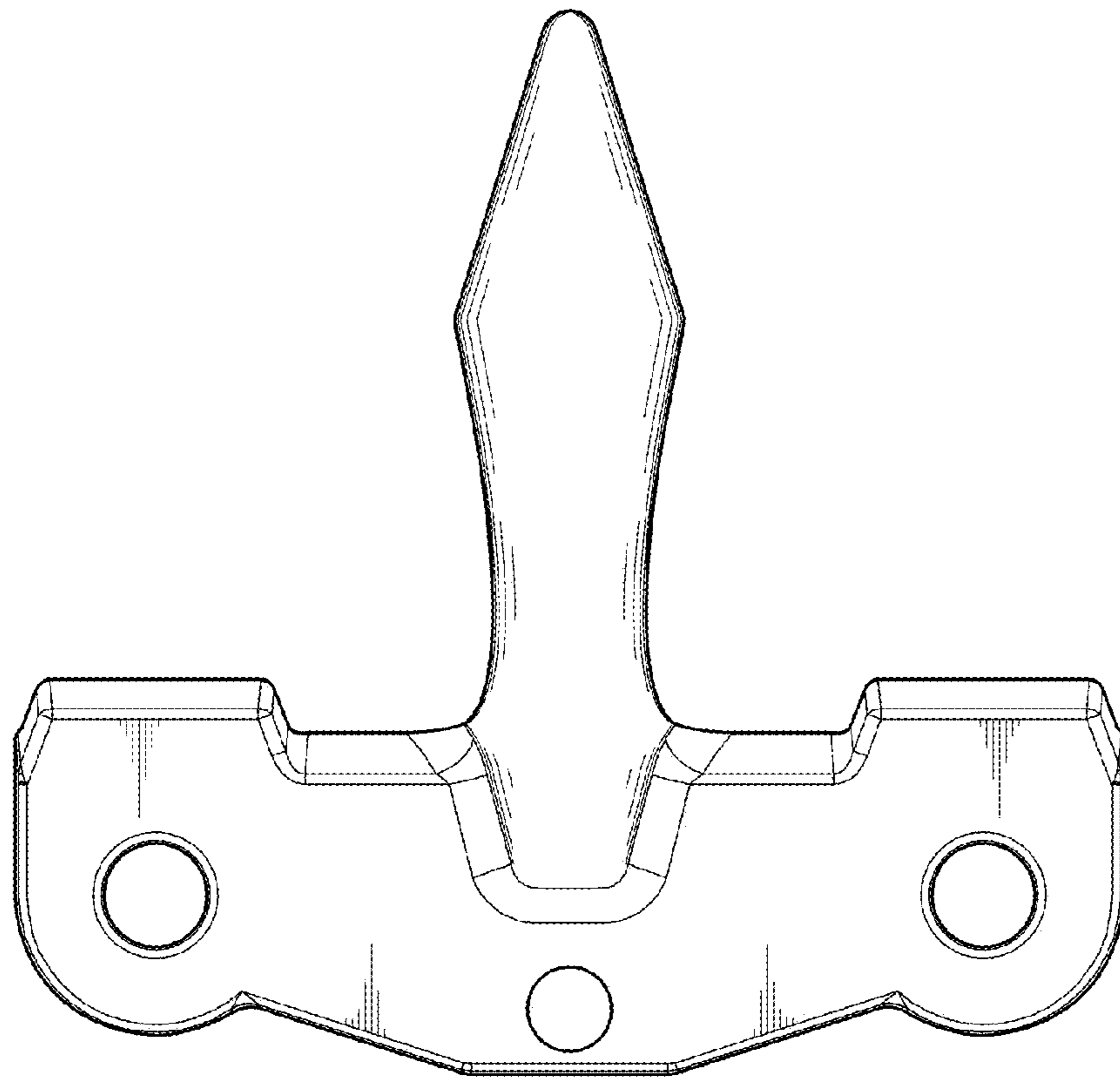

**FIG. 2**

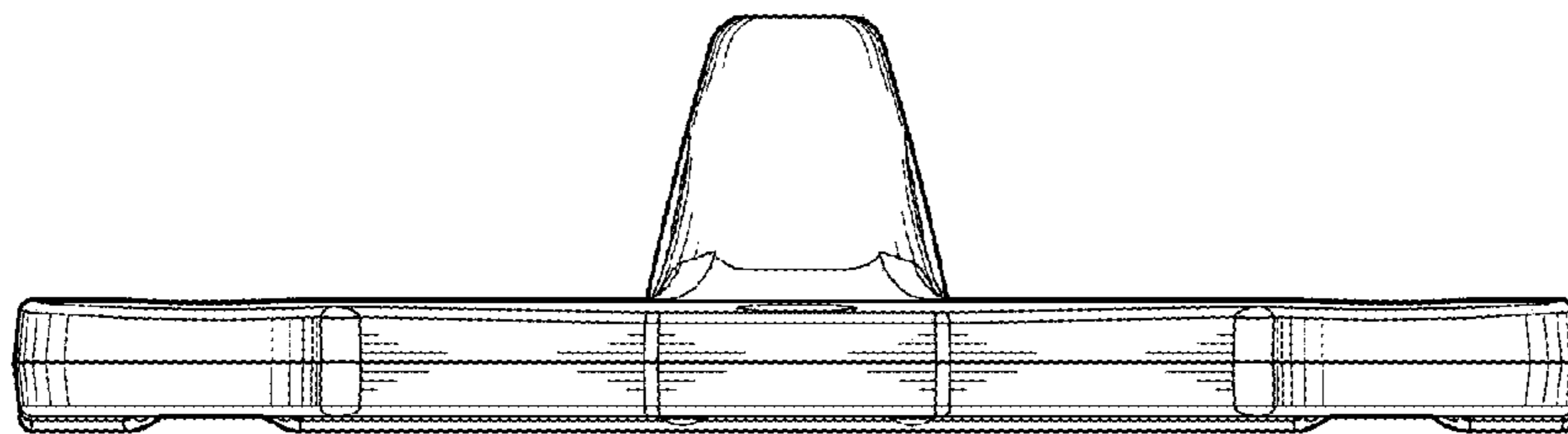

**FIG. 3**

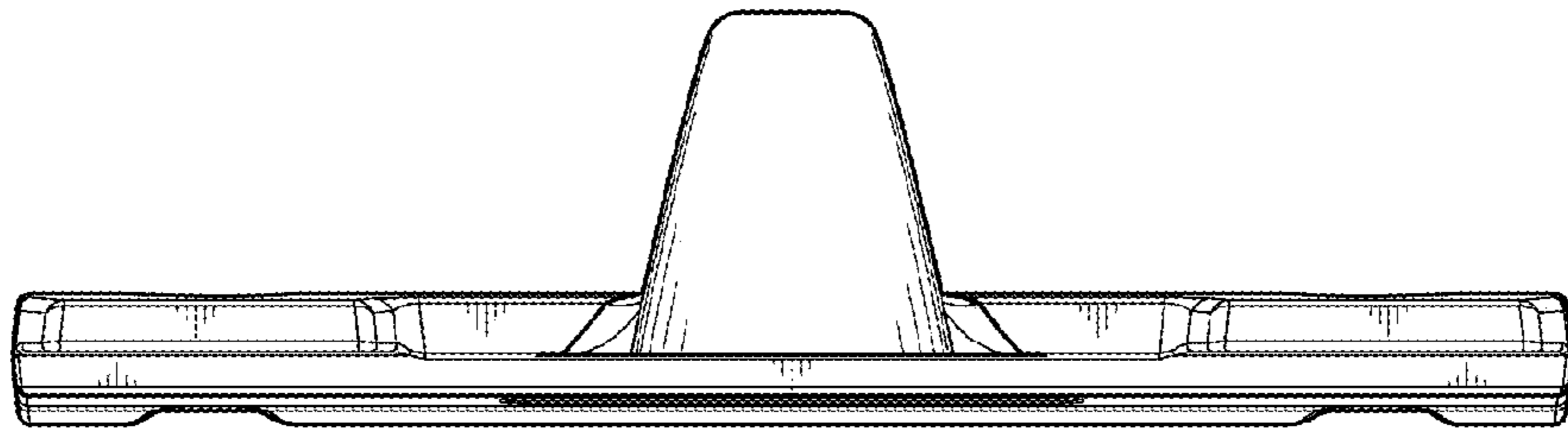

**FIG. 4**

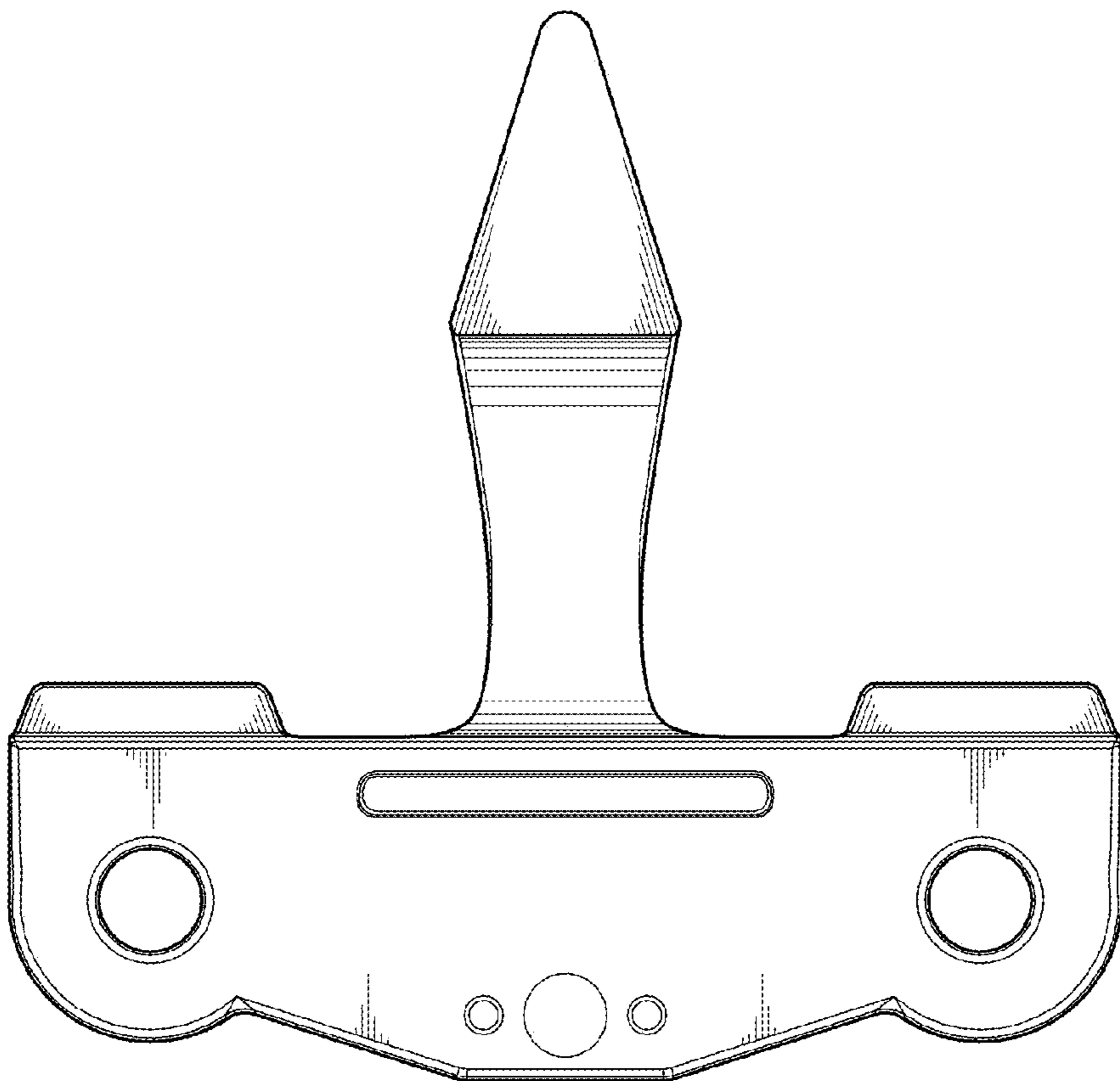

**FIG. 5**

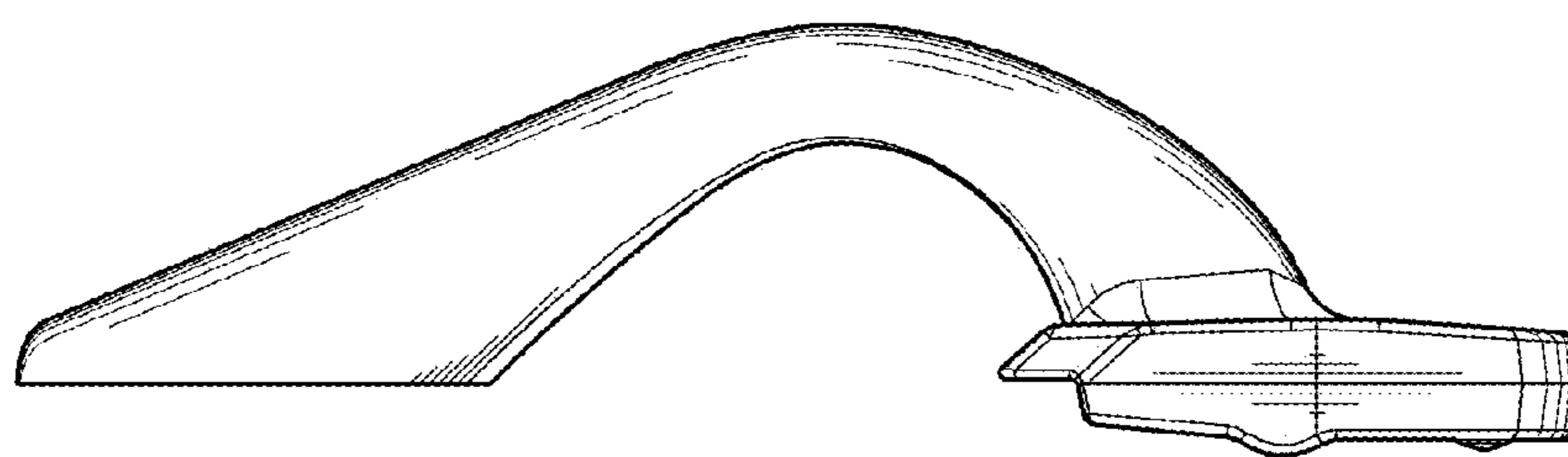

**FIG. 6**

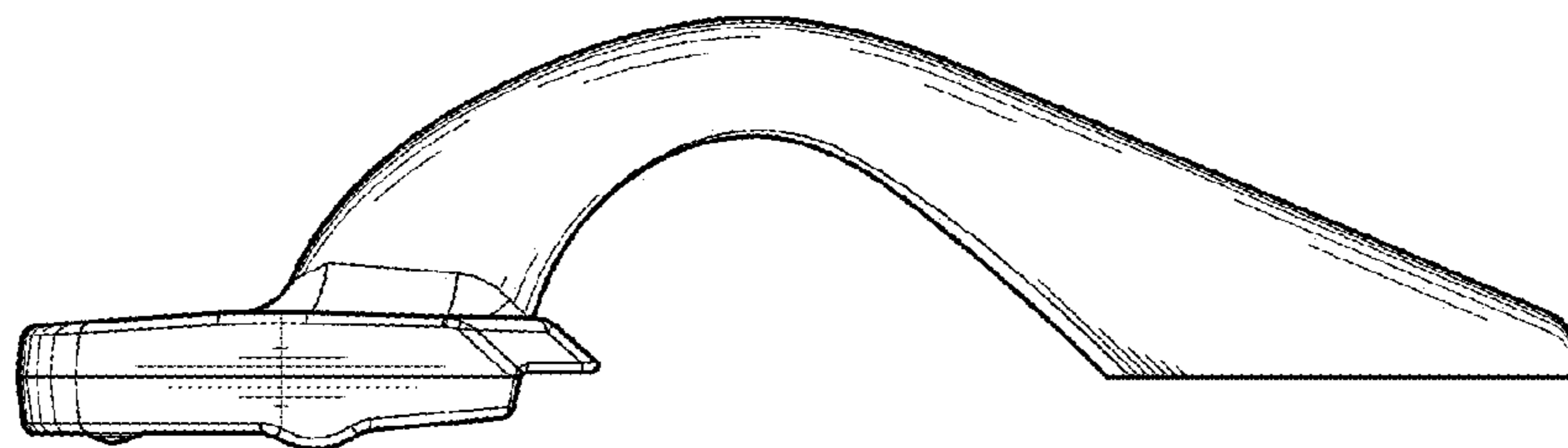

**FIG. 7**