



US00D713986S

(12) **United States Design Patent**
Auras

(10) **Patent No.:** **US D713,986 S**

(45) **Date of Patent:** **** Sep. 23, 2014**

(54) **AIRPORT-LIGHTING TAXIWAY CURVE**

(75) Inventor: **Klaus Auras**, Lippstadt (DE)

(73) Assignee: **Hella KGAA Hueck & Co.** (DE)

(**) Term: **14 Years**

(21) Appl. No.: **29/416,606**

(22) Filed: **Mar. 23, 2012**

(30) **Foreign Application Priority Data**

Sep. 23, 2011 (EM) 001921966-0004

(51) **LOC (10) Cl.** **26-05**

(52) **U.S. Cl.**
USPC **D26/67**

(58) **Field of Classification Search**
USPC D26/51, 60-63, 67, 72, 74, 85, 113,
D26/118, 120, 139; D10/106.2, 106.5,
D10/114.1; 362/146, 148, 152, 153, 153.1,
362/181, 217.01, 235, 249.01, 267, 310,
362/315, 364, 365, 390, 555, 558-560,
362/632-634

See application file for complete search history.

(56) **References Cited**

U.S. PATENT DOCUMENTS

D183,068	S	*	6/1958	Spaulding	D26/24
2,848,597	A	*	8/1958	Knottnerus	362/227
3,007,034	A	*	10/1961	Reed et al.	362/153
3,066,217	A	*	11/1962	McDonald	362/297
3,155,321	A	*	11/1964	McDonald	362/223
3,200,243	A	*	8/1965	McDevitt et al.	362/153
3,327,104	A	*	6/1967	Loch	362/223
3,369,114	A	*	2/1968	Carter	362/382
3,697,736	A	*	10/1972	Frederiksen	362/235
D246,131	S	*	10/1977	Schifrin	D26/28
4,382,274	A	*	5/1983	De Backer et al.	362/153
4,617,616	A	*	10/1986	Juell et al.	362/267
4,924,364	A	*	5/1990	Pannier	362/153.1

D312,319	S	*	11/1990	Kunz	D26/72
5,669,691	A	*	9/1997	Barrow	362/153.1
D415,588	S	*	10/1999	Hann	D26/139
6,033,083	A	*	3/2000	Reinert, Sr.	362/153.1
6,113,245	A	*	9/2000	Reinert, Sr.	362/153.1

(Continued)

FOREIGN PATENT DOCUMENTS

JP	2001184907	A	*	7/2001	B64F 1/36
JP	2005259466	A	*	9/2005	E01F 9/06
KR	952375	B1	*	4/2010	F21V 29/00

OTHER PUBLICATIONS

Flight Light Inc., Taxiway Centerline Straight Section FAA Light Type L-852A and L-852C "H" Series, Jan. 28, 2006, Products Website, http://www.flightlight.com/airportlighting/honeywell_web/H40_TaxiwayCenterline/H40.html.*

Primary Examiner — Garth Rademaker
Assistant Examiner — Llorellys Martinez-Rivera
(74) *Attorney, Agent, or Firm* — Quarles & Brady LLP

(57) **CLAIM**

The ornamental design for an airport-lighting taxiway curve, as shown and described.

DESCRIPTION

FIG. 1 is a top, front, right perspective view of an airport-lighting taxiway curve embodying my new design;
FIG. 2 is a top plan view thereof;
FIG. 3 is a front elevational view thereof;
FIG. 4 is an enlarged, cross-section detailed view taken along line 4-4 of FIG. 2; and,
FIG. 5 is an enlarged, cross-section detailed view taken along line 5-5 of FIG. 2.
The dash-dash broken line representations in the views are for the purpose of illustrating unclaimed environment of the claimed design. The dot-dash-dot broken line representations define unclaimed boundaries of the claimed design.

1 Claim, 3 Drawing Sheets

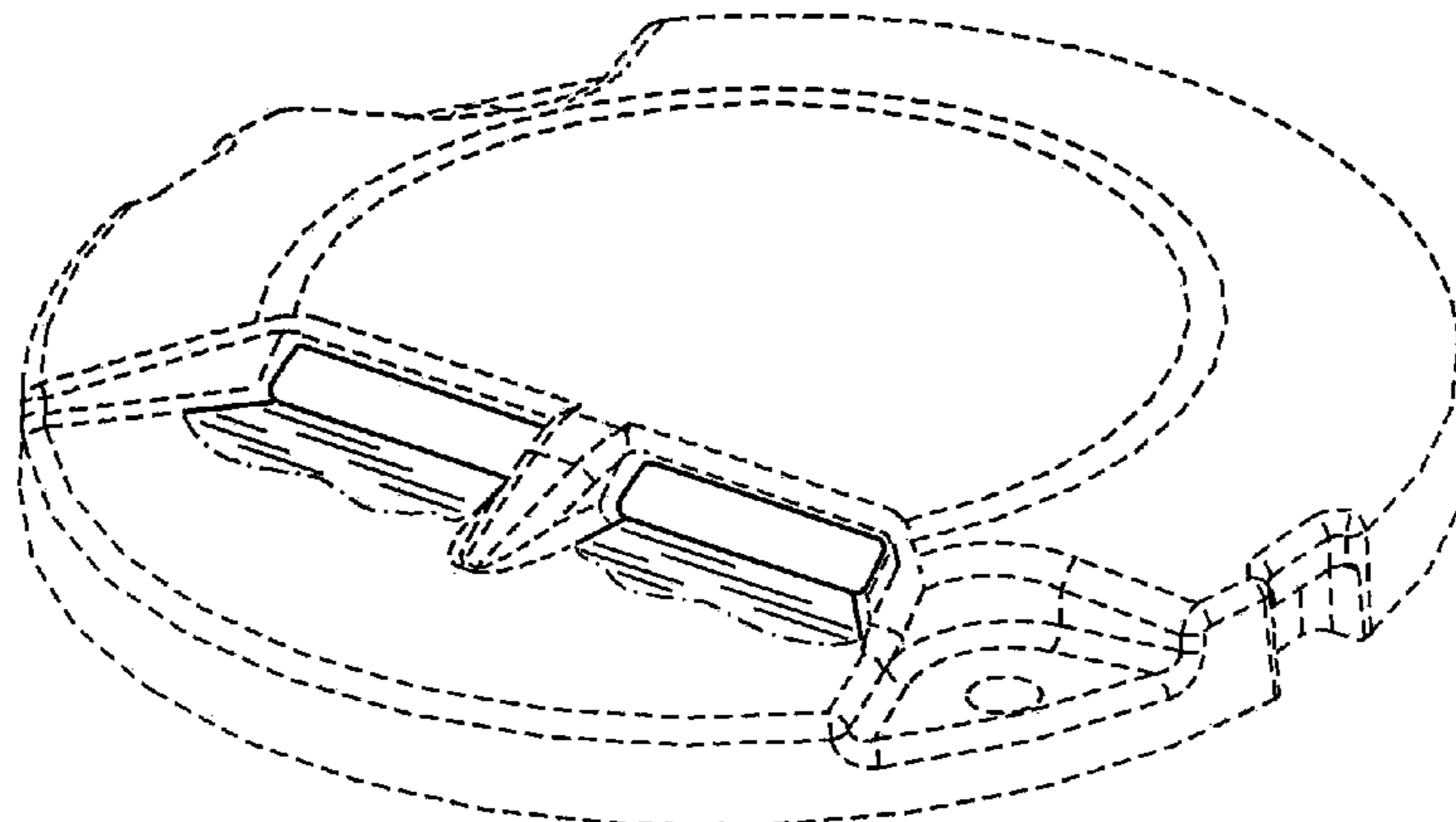

(56)

References Cited

U.S. PATENT DOCUMENTS

D589,638 S * 3/2009 Collins D26/72
D617,929 S * 6/2010 Kuo D26/60
D623,326 S * 9/2010 Chen D26/63
D632,008 S * 2/2011 Kim et al. D26/120
7,878,673 B2 * 2/2011 Kempkey et al. 362/555
D643,951 S * 8/2011 Cai D26/28
8,138,661 B2 * 3/2012 Kokubu et al. 362/555
8,152,347 B2 * 4/2012 Brukilacchio 362/555

D670,421 S * 11/2012 Herberholt D26/63
D676,993 S * 2/2013 Kotsis et al. D26/46
D680,253 S * 4/2013 Herberholt D26/60
D682,133 S * 5/2013 Chen D10/114.1
D690,444 S * 9/2013 Katoh et al. D26/1
D690,847 S * 10/2013 Wang D26/24
2001/0010803 A1 * 8/2001 Freeman et al. D26/6
2007/0139959 A1 * 6/2007 Yang 362/603
2008/0094679 A1 * 4/2008 Wang et al. 362/555
2009/0027914 A1 * 1/2009 Wu 362/555
2013/0170205 A1 * 7/2013 Abel et al. 362/249.01

* cited by examiner

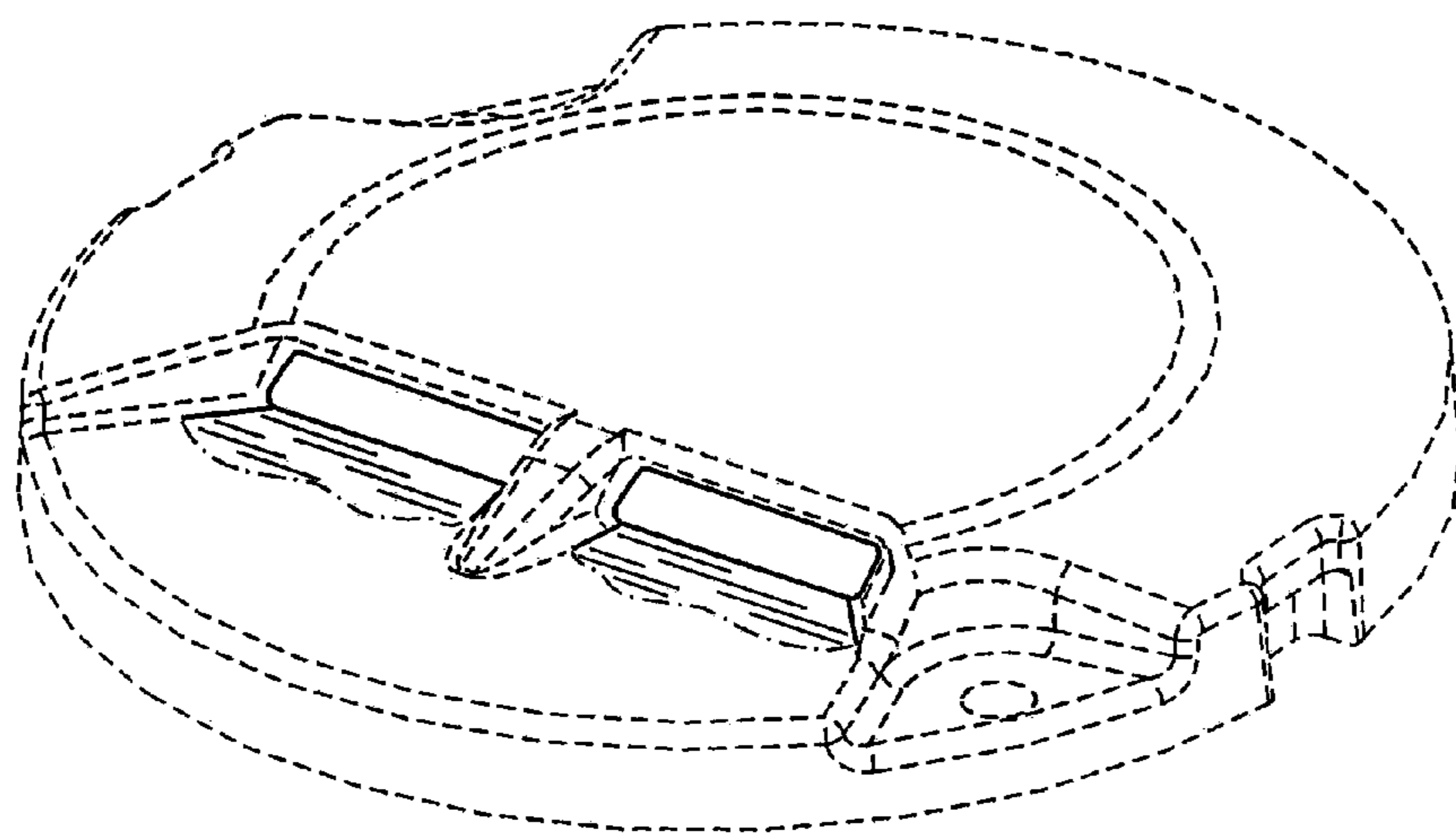

FIG. 1

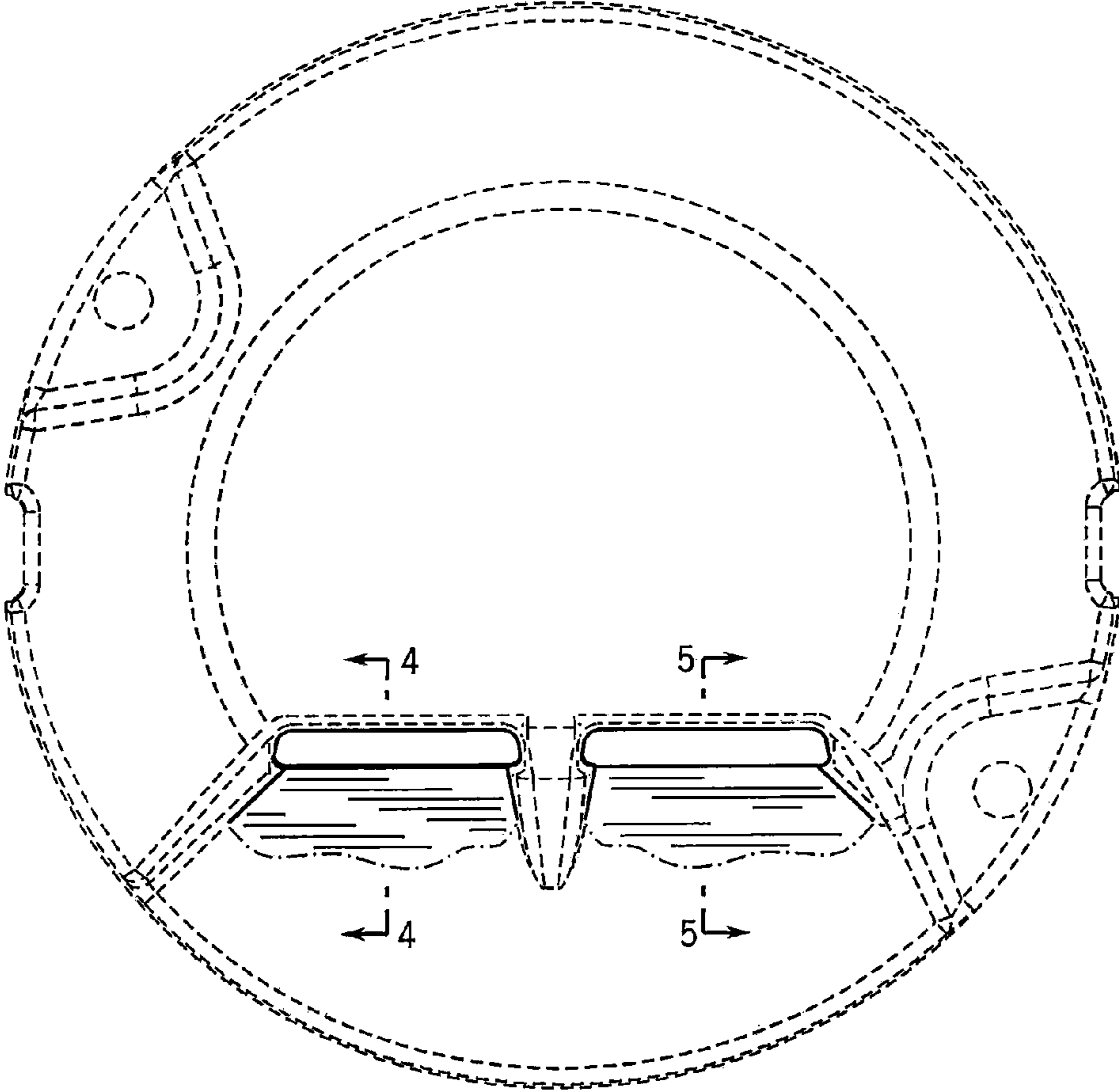

FIG. 2

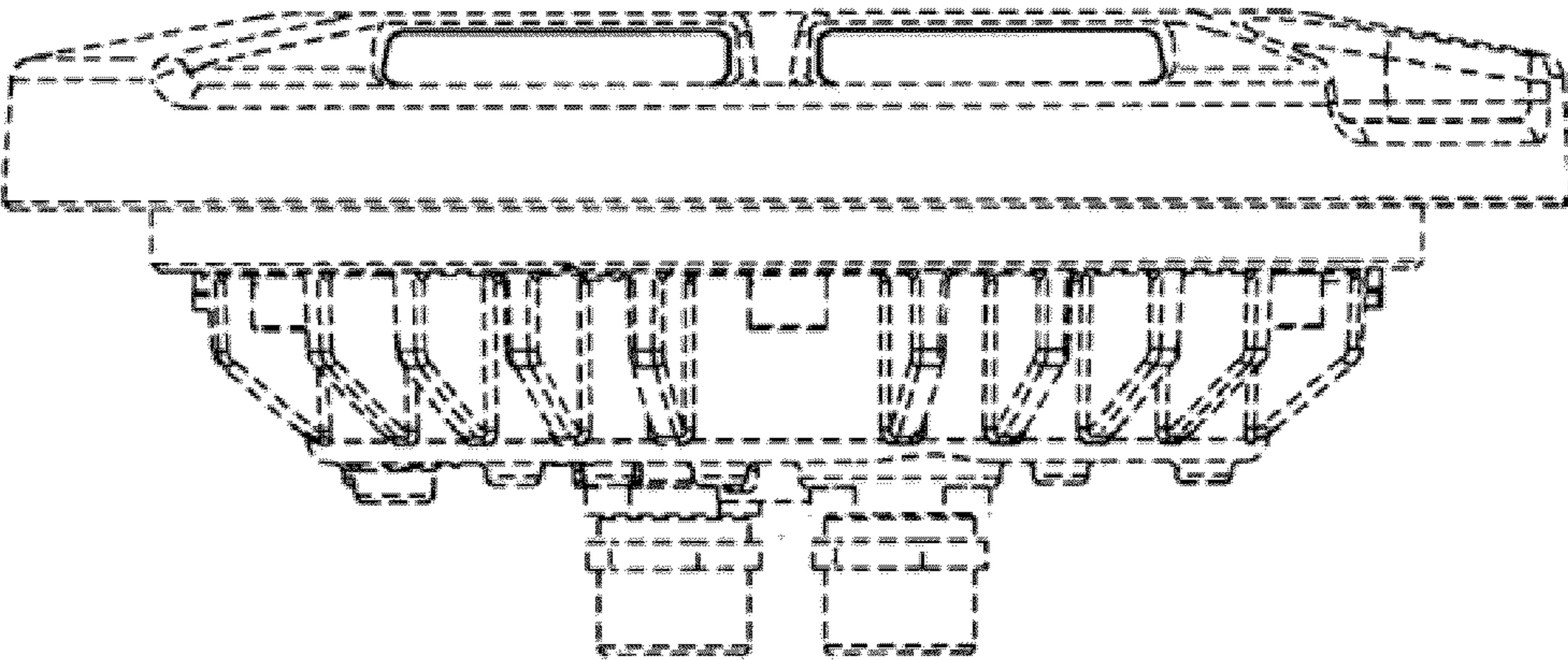

FIG. 3

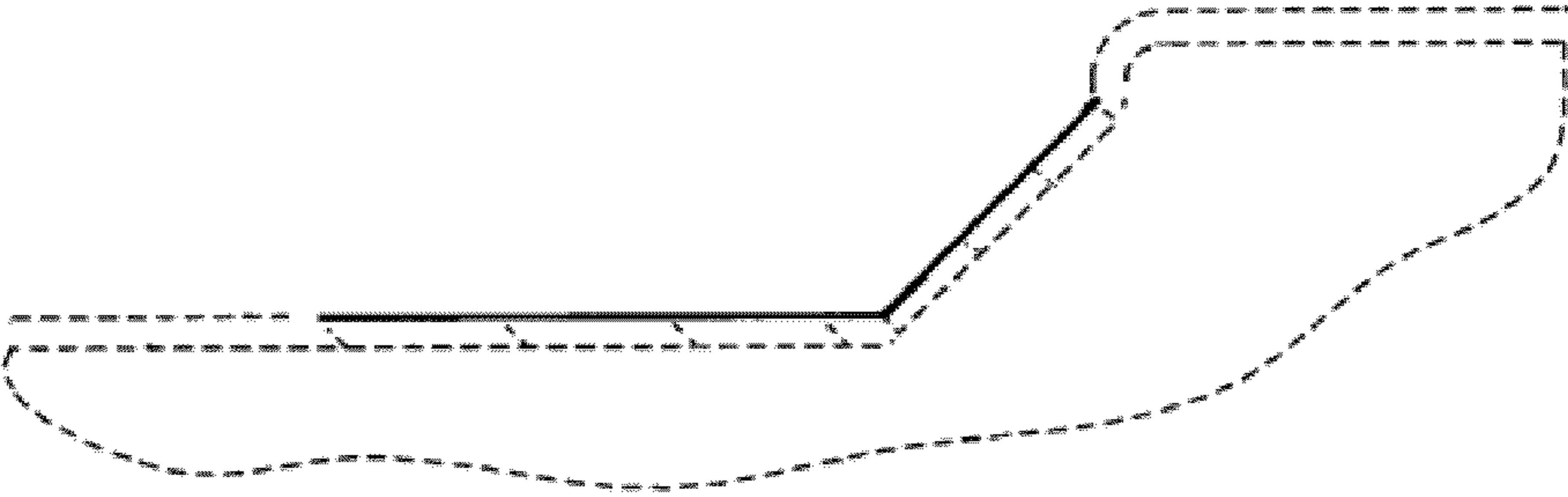

FIG. 4

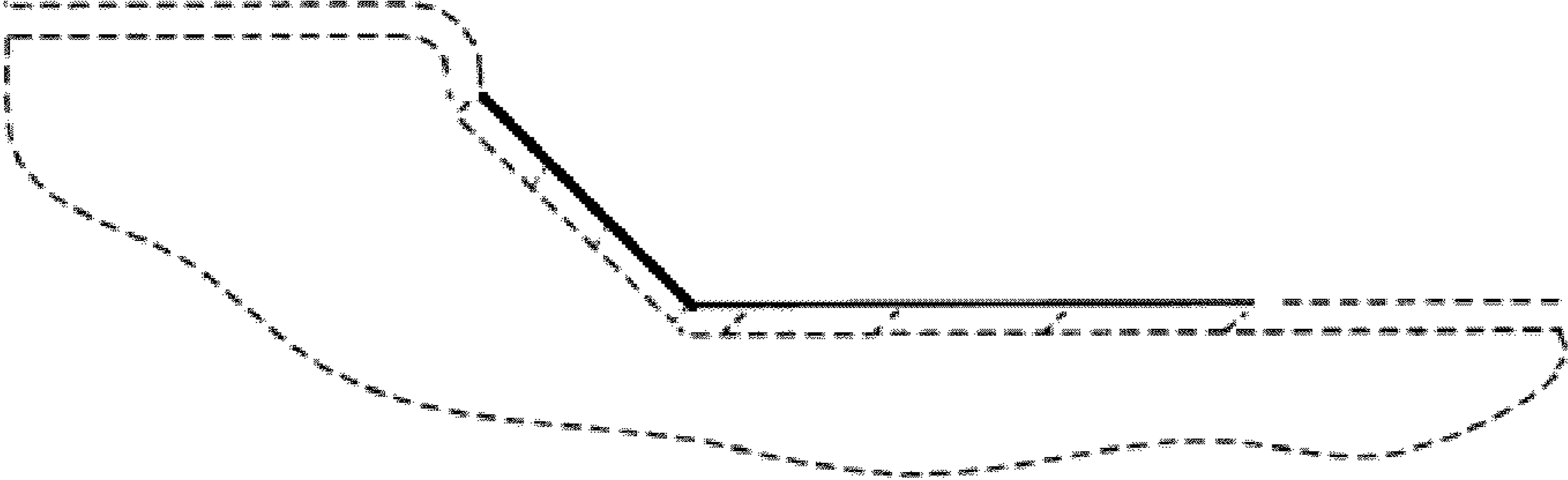

FIG. 5