



US00D713931S

(12) **United States Design Patent**
Dobias et al.

(10) **Patent No.:** **US D713,931 S**
(45) **Date of Patent:** **** Sep. 23, 2014**

(54) **SPRAYER**
(71) Applicant: **Central Garden & Pet Company,**
Walnut Creek, CA (US)
(72) Inventors: **Scott F. Dobias,** Johns Creek, GA (US);
Antonio Gatta, Philadelphia, PA (US);
Christopher Murray, Philadelphia, PA
(US); **Christopher Phelan,**
Collingswood, NJ (US); **David Schiff,**
Highland Park, NJ (US); **Mathieu**
Zastawny, Philadelphia, PA (US)

(73) Assignee: **Central Garden & Pet Company,**
Walnut Creek, CA (US)

(**) Term: **14 Years**

(21) Appl. No.: **29/445,683**

(22) Filed: **Feb. 14, 2013**

Related U.S. Application Data

(63) Continuation-in-part of application No. 13/737,593,
filed on Jan. 9, 2013.

(51) **LOC (10) Cl.** **23-01**

(52) **U.S. Cl.**
USPC **D23/213**

(58) **Field of Classification Search**
USPC D23/213, 223, 225, 226; 239/302, 308,
239/310, 332, 333, 337, 526; 222/465.1,
222/383.1, 383.3, 143, 154; D8/1, 2
See application file for complete search history.

(56) **References Cited**

U.S. PATENT DOCUMENTS

555,318 A 2/1896 Hitt
2,031,672 A 2/1936 Schaefer
2,083,058 A 6/1937 De Weal
2,164,885 A 7/1939 Raiche
2,334,905 A 11/1943 Cherkin
2,372,154 A 3/1945 Ahern
2,500,119 A 3/1950 Cooper
2,536,277 A 1/1951 Grieme

2,564,058 A 8/1951 Fletcher et al.
2,715,481 A 8/1955 McGhie et al.
2,882,940 A 4/1959 Zellweger
3,092,106 A 6/1963 Butler
3,098,589 A 7/1963 Graham
3,116,856 A 1/1964 Prussin et al.
3,131,712 A 5/1964 Risley et al.
3,148,806 A 9/1964 Meshberg
3,200,994 A 8/1965 Levinson et al.
3,255,933 A 6/1966 Martin
3,402,862 A 9/1968 Meshberg
3,542,240 A 11/1970 Solowey
3,554,450 A 1/1971 D'Muhala
3,685,694 A 8/1972 Ianelli
3,788,519 A 1/1974 Mengel
3,828,973 A 8/1974 Birrell
3,893,630 A 7/1975 Bochmann
3,901,449 A 8/1975 Bochmann
3,904,116 A 9/1975 Jones et al.
3,926,339 A 12/1975 Openchowski
3,952,918 A 4/1976 Poitras et al.
3,953,902 A 5/1976 Taylor
3,974,930 A 8/1976 Gizard et al.
3,995,772 A 12/1976 Liautaud
4,039,105 A 8/1977 Chan
4,081,006 A 3/1978 Crowell et al.
4,173,295 A 11/1979 Steinmann
4,177,828 A 12/1979 Vache
D254,321 S 2/1980 Sidor et al.
4,186,849 A 2/1980 Spangler
4,189,068 A 2/1980 Apellaniz
D272,380 S 1/1984 Poon
4,512,955 A 4/1985 Etani
4,529,106 A 7/1985 Broadfoot et al.
4,618,099 A 10/1986 Nagao et al.
4,621,770 A * 11/1986 Sayen 239/304
4,699,188 A 10/1987 Baker et al.
4,790,454 A 12/1988 Clark
4,793,501 A 12/1988 Beck
4,801,088 A 1/1989 Baker
4,925,105 A 5/1990 Lin
4,955,544 A 9/1990 Kopp
RE33,539 E 2/1991 Karpal
4,994,042 A 2/1991 Vadher
5,020,220 A 6/1991 Miyake et al.
5,029,738 A 7/1991 Dillon
5,086,950 A 2/1992 Crossdale et al.
5,104,003 A 4/1992 Stecoza
5,118,009 A 6/1992 Novitsky
5,148,912 A 9/1992 Nozawa
5,150,841 A 9/1992 Silvenis et al.
5,154,324 A 10/1992 Stratford
5,156,298 A 10/1992 LaRue

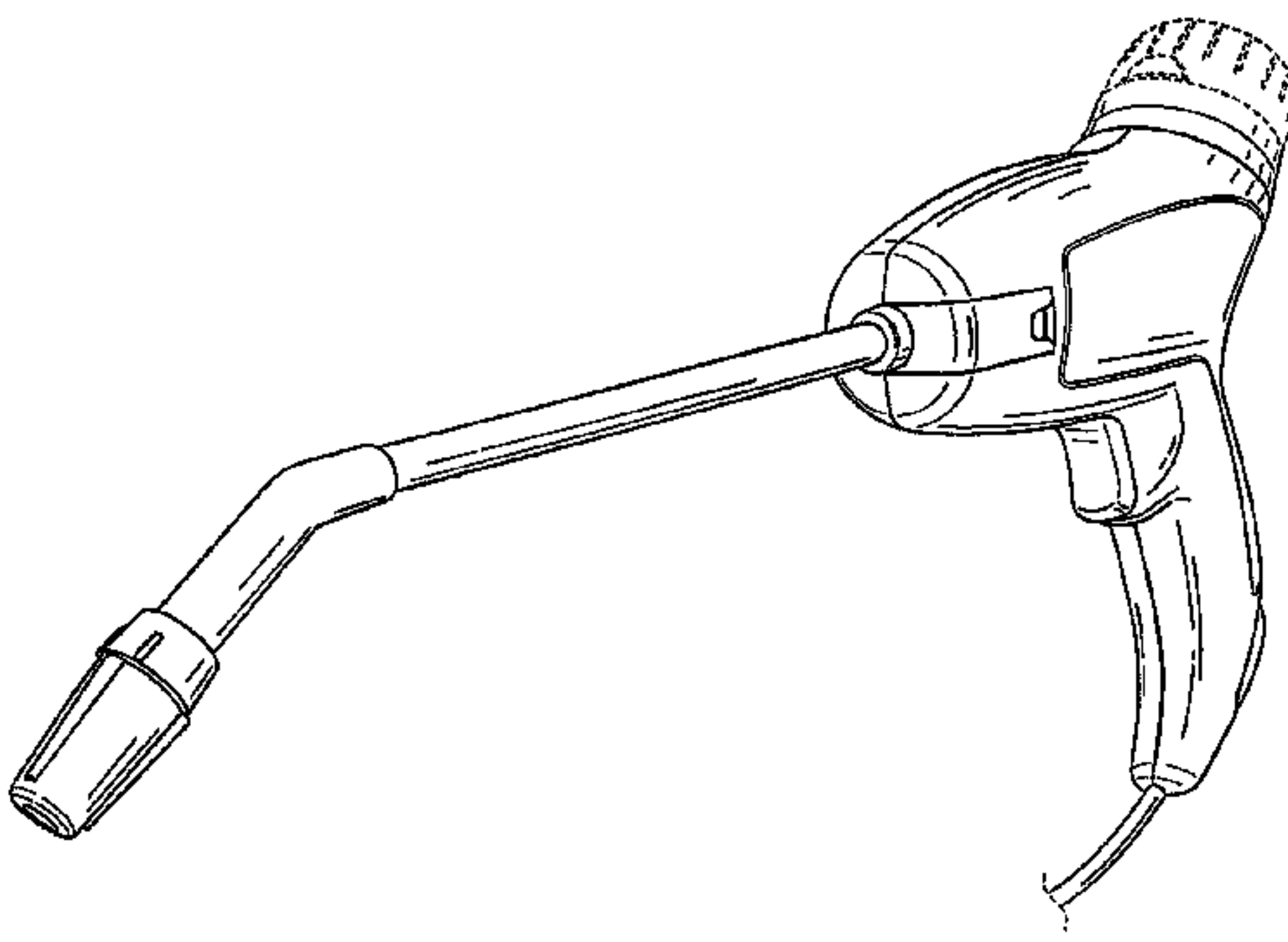
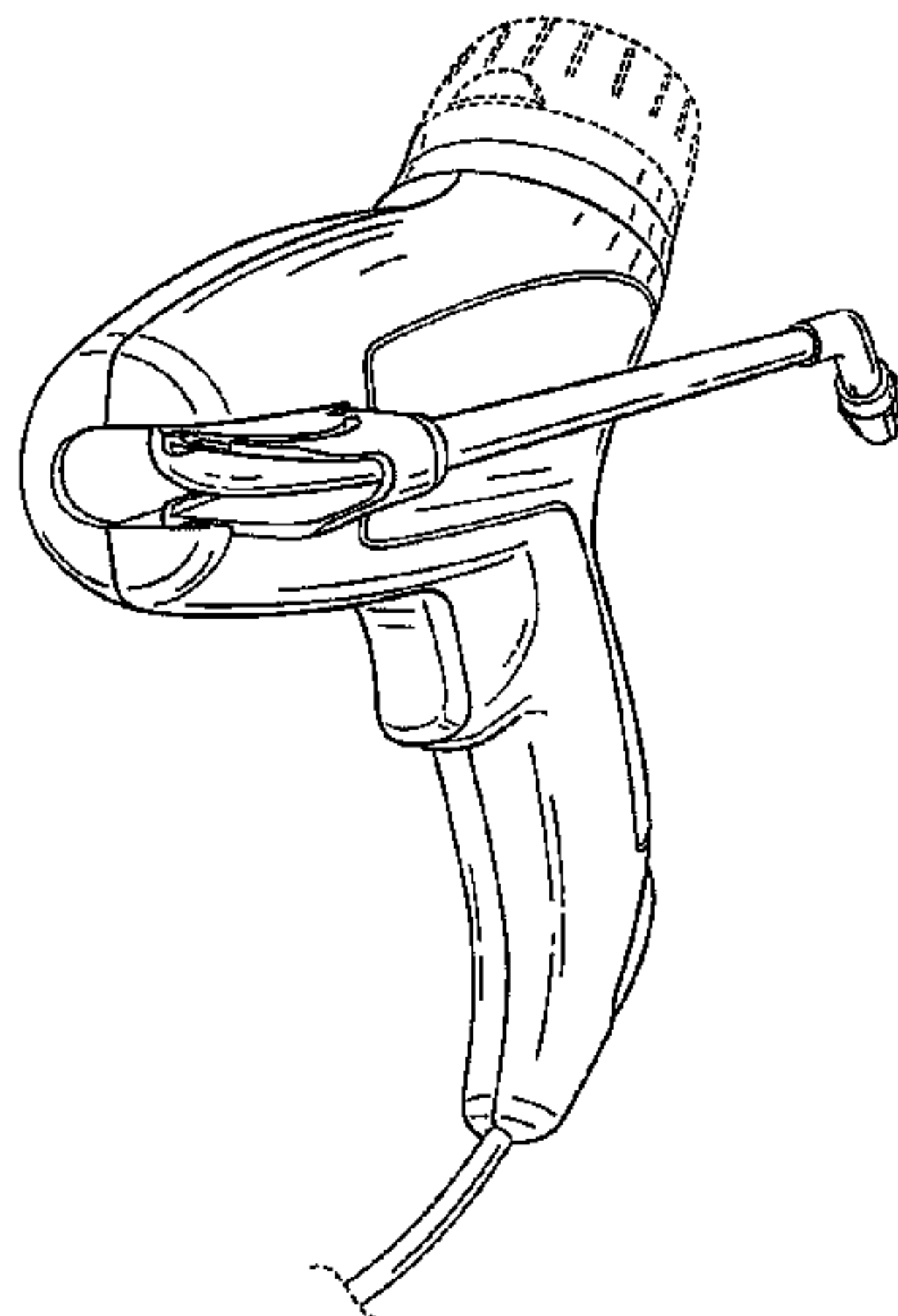

5,199,948 A 4/1993 McPhee
 5,215,537 A 6/1993 Lynn et al.
 5,273,186 A 12/1993 Widmer
 5,332,158 A 7/1994 Styne et al.
 5,338,304 A 8/1994 Adams
 D350,287 S 9/1994 Kobayashi et al.
 5,358,491 A 10/1994 Johnson et al.
 D352,344 S 11/1994 Mizuguchi
 5,370,164 A 12/1994 Galloway
 5,415,324 A 5/1995 Coventry
 5,417,350 A 5/1995 Koo
 5,425,404 A 6/1995 Dyer
 5,425,528 A 6/1995 Rains et al.
 5,435,462 A 7/1995 Fujii
 5,469,993 A * 11/1995 Hauf et al. 222/383.3
 5,487,728 A 1/1996 Vaillancourt
 5,490,614 A 2/1996 Sardynski
 5,509,551 A 4/1996 Terrell, II
 5,524,795 A 6/1996 Lee
 5,526,963 A 6/1996 Smith
 5,553,750 A * 9/1996 Foster 222/179.5
 5,575,777 A 11/1996 Cover et al.
 5,582,350 A 12/1996 Kosmyna et al.
 5,591,138 A 1/1997 Vaillancourt
 5,595,566 A 1/1997 Vallelunga et al.
 5,601,211 A * 2/1997 Foster 222/143
 5,716,007 A 2/1998 Nottingham et al.
 5,732,853 A 3/1998 Ganzeboom et al.
 5,752,661 A 5/1998 Lewis
 5,816,449 A 10/1998 Tanno et al.
 5,827,486 A 10/1998 Crossdale
 5,840,189 A 11/1998 Sylvan et al.
 5,842,682 A 12/1998 Schennum et al.
 5,860,574 A * 1/1999 Shanklin et al. 222/530
 5,875,921 A 3/1999 Osgar et al.
 5,893,397 A 4/1999 Peterson et al.
 5,896,898 A 4/1999 Crossdale et al.
 5,897,013 A 4/1999 Manganiello
 5,951,489 A 9/1999 Bauer
 5,967,197 A 10/1999 Shown
 6,017,329 A 1/2000 Hake
 6,050,459 A 4/2000 Johnson et al.
 D424,167 S 5/2000 Yuen et al.
 6,095,370 A 8/2000 Rhine et al.
 6,109,480 A 8/2000 Monsrud et al.
 6,145,711 A 11/2000 Prosper et al.
 6,152,327 A 11/2000 Rhine et al.
 6,321,941 B1 11/2001 Argentieri et al.
 6,367,665 B1 4/2002 Barriac et al.
 6,386,392 B1 5/2002 Argentieri et al.
 6,390,335 B1 5/2002 Lawson et al.
 6,409,052 B1 6/2002 Barriac et al.
 6,419,128 B1 7/2002 Barriac et al.
 6,508,410 B1 * 1/2003 Thomas et al. 239/1
 6,511,001 B1 1/2003 Huang
 6,551,001 B2 4/2003 Aberegg et al.
 6,554,319 B2 4/2003 Barriac et al.
 6,561,438 B1 * 5/2003 Restive et al. 239/428.5
 6,644,564 B2 11/2003 Perkitny
 6,685,056 B1 2/2004 Argentieri et al.
 6,716,197 B2 4/2004 Svendsen
 6,796,464 B1 9/2004 Tung
 6,811,100 B2 11/2004 Bardinet et al.
 6,820,769 B2 * 11/2004 Foster et al. 222/153.13
 6,824,025 B1 11/2004 Ruble et al.
 6,971,549 B2 12/2005 Leifheit et al.
 6,971,589 B2 12/2005 Incardona et al.
 7,032,841 B1 4/2006 Swisher
 D524,906 S 7/2006 Birrenkott et al.
 7,097,119 B2 8/2006 Hornsby et al.
 D529,575 S 10/2006 Birrenkott et al.
 7,156,324 B2 1/2007 Birrenkott et al.
 D536,970 S 2/2007 Shannan et al.
 7,182,280 B2 2/2007 Ye et al.
 7,204,382 B2 4/2007 Cezeaux
 7,207,500 B2 4/2007 Hudson et al.
 7,246,755 B2 7/2007 Hornsby et al.
 7,325,706 B2 2/2008 Sweeton et al.
 7,328,859 B2 2/2008 Hornsby et al.

7,337,989 B1 3/2008 Penner et al.
 D569,478 S 5/2008 Cichy et al.
 7,384,006 B2 6/2008 Hornsby et al.
 7,398,726 B2 7/2008 Streeter et al.
 7,470,237 B2 12/2008 Beckman et al.
 7,513,444 B1 4/2009 Kurimski et al.
 7,562,834 B2 7/2009 Hornsby et al.
 7,563,256 B2 7/2009 Hearne
 7,568,637 B2 8/2009 Hornsby et al.
 7,588,198 B2 9/2009 Hornsby et al.
 D602,117 S 10/2009 Fontaine
 7,631,818 B2 * 12/2009 Wu 239/302
 7,690,392 B1 4/2010 Sarkiss
 7,717,354 B1 * 5/2010 Robinson 239/1
 7,753,887 B2 7/2010 Botich et al.
 7,819,292 B2 10/2010 Arcuri et al.
 7,971,803 B1 7/2011 Barlowe
 8,056,774 B2 11/2011 Arcuri et al.
 8,100,302 B2 * 1/2012 Bonner 222/401
 8,141,754 B2 * 3/2012 Conner et al. 222/333
 D670,788 S 11/2012 Plantz et al.
 D670,982 S 11/2012 Goodwin et al.
 D678,464 S 3/2013 Chen
 2004/0050959 A1 3/2004 Mazooji et al.
 2004/0084552 A1 5/2004 Huartson
 2005/0082389 A1 4/2005 Sanchez et al.
 2007/0131794 A1 6/2007 Lai et al.
 2008/0061167 A1 3/2008 Gansebom
 2008/0296398 A1 12/2008 Hickman et al.
 2010/0193517 A1 8/2010 Takanohashi
 2010/0243760 A1 9/2010 Birrenkott et al.
 2010/0282866 A1 11/2010 Gilpatrick et al.
 2011/0062159 A1 3/2011 Khubani
 2012/0037625 A1 2/2012 Hasunuma et al.
 2012/0223160 A1 9/2012 Goodwin et al.
 2013/0175363 A1 7/2013 Dobias et al.
 2013/0193232 A1 8/2013 Dobias et al.

FOREIGN PATENT DOCUMENTS

CA 2007887 7/1990
 CA 2075473 8/1991
 CA 2157597 9/1994
 CA 2008148 9/2002
 CA 2091020 1/2005
 EP 0369722 B1 8/1993
 EP 2 439 357 4/2012
 GB 2264702 A 9/1993
 GB 2339772 A 2/2000
 WO WO-83/00932 3/1983
 WO WO 2009/055588 4/2009
 WO WO-2010/059494 A2 5/2010

OTHER PUBLICATIONS

One Stop Gardens Lawn & Garden Motorized Caddy Sprayer—2 Gallon, Model 96622: Cleaning, Assembly, and Operation Instructions, 2007, cover and pp. 2-10, Harbor Freight Tools, Camarillo, California.

U.S. Appl. No. 13/803,245, filed Mar. 14, 2013, Dobias et al. International Search Report and Written Opinion of the International Searching Authority issued in corresponding International Application No. PCT/US2013/036704, mailed Feb. 4, 2014.

* cited by examiner

Primary Examiner — Robin V Webster
 (74) Attorney, Agent, or Firm — Womble, Carlyle Sandridge & Rice, LLP

(57)

CLAIM

The ornamental design for a sprayer, as shown and described.

DESCRIPTION

FIG. 1 is a front pictorial view of a sprayer in a first configuration, in accordance with a first embodiment of the invention;

FIG. 2 is a rear pictorial view of the sprayer of FIG. 1 in the first configuration;
FIG. 3 is a front elevation view of the sprayer of FIG. 1 in the first configuration;
FIG. 4 is a rear elevation view of the sprayer of FIG. 1 in the first configuration;
FIG. 5 is a left elevation view of the sprayer of FIG. 1 in the first configuration;
FIG. 6 is a right elevation view of the sprayer of FIG. 1 in the first configuration;
FIG. 7 is a top plan view of the sprayer of FIG. 1 in the first configuration;
FIG. 8 is a bottom plan view of the sprayer of FIG. 1 in the first configuration;
FIG. 9 is a front pictorial view of the sprayer of FIG. 1 in a second configuration;
FIG. 10 is a rear pictorial view of the sprayer of FIG. 1 in the second configuration;
FIG. 11 is a front elevation view of the sprayer of FIG. 1 in the second configuration;
FIG. 12 is a rear elevation view of the sprayer of FIG. 1 in the second configuration;
FIG. 13 is a left elevation view of the sprayer of FIG. 1 in the second configuration;
FIG. 14 is a right elevation view of the sprayer of FIG. 1 in the second configuration;
FIG. 15 is a top plan view of the sprayer of FIG. 1 in the second configuration;
FIG. 16 is a bottom plan view of the sprayer of FIG. 1 in the second configuration;
FIG. 17 is a front pictorial view of a sprayer in a first configuration, in accordance with a second embodiment of the invention;

FIG. 18 is a rear pictorial view of the sprayer of FIG. 17 in the first configuration;
FIG. 19 is a front elevation view of the sprayer of FIG. 17 in the first configuration;
FIG. 20 is a rear elevation view of the sprayer of FIG. 17 in the first configuration;
FIG. 21 is a left elevation view of the sprayer of FIG. 17 in the first configuration;
FIG. 22 is a right elevation view of the sprayer of FIG. 17 in the first configuration;
FIG. 23 is a top plan view of the sprayer of FIG. 17 in the first configuration;
FIG. 24 is a bottom plan view of the sprayer of FIG. 17 in the first configuration;
FIG. 25 is a front pictorial view of the sprayer of FIG. 17 in a second configuration;
FIG. 26 is a rear pictorial view of the sprayer of FIG. 17 in the second configuration;
FIG. 27 is a front elevation view of the sprayer of FIG. 17 in the second configuration;
FIG. 28 is a rear elevation view of the sprayer of FIG. 17 in the second configuration;
FIG. 29 is a left elevation view of the sprayer of FIG. 17 in the second configuration;
FIG. 30 is a right elevation view of the sprayer of FIG. 17 in the second configuration;
FIG. 31 is a top plan view of the sprayer of FIG. 17 in the second configuration; and,
FIG. 32 is a bottom plan view of the sprayer of FIG. 17 in the second configuration.
The broken line showing is included for the purpose of illustrating and forms no part of the claimed design.

1 Claim, 20 Drawing Sheets

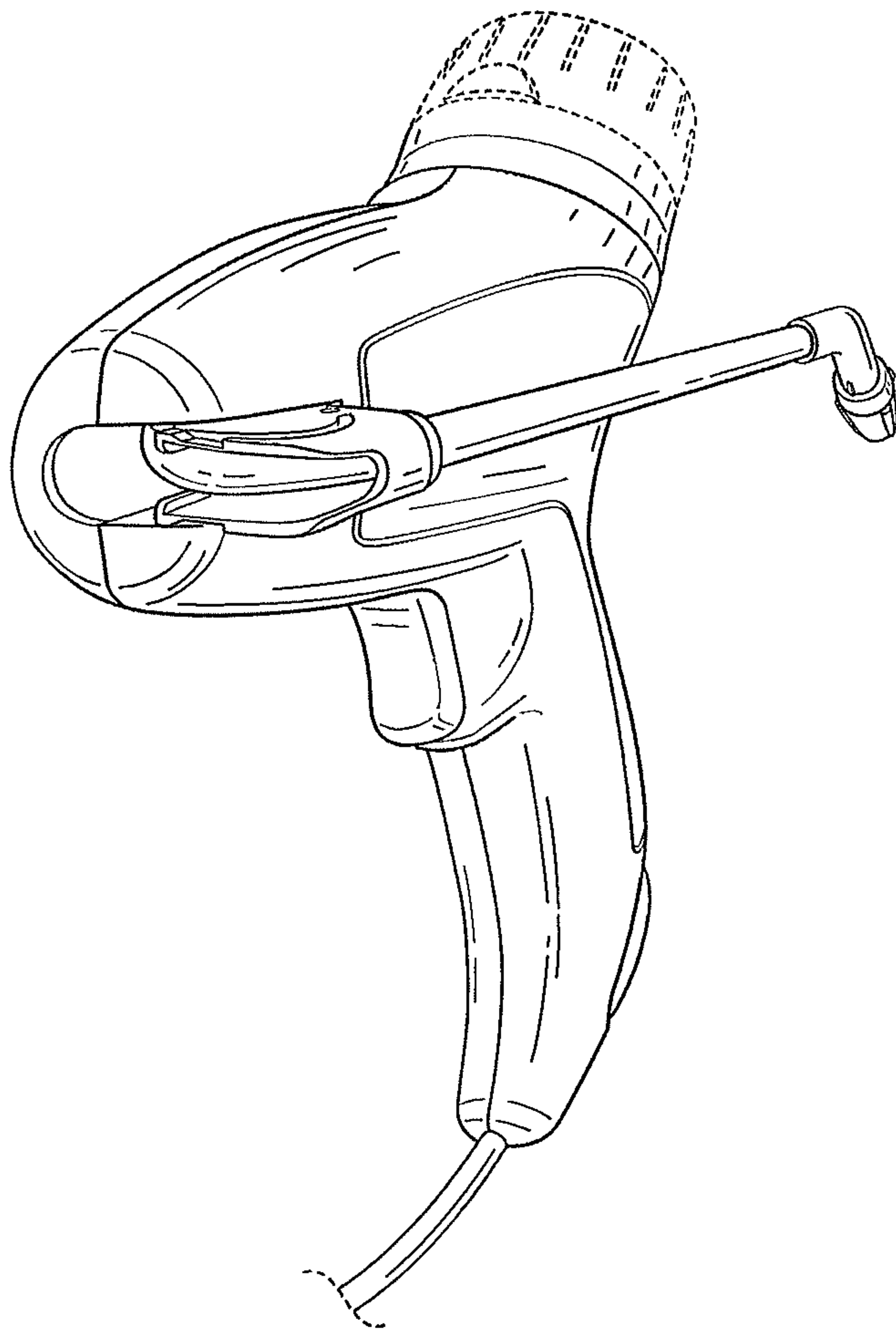

FIG. 1

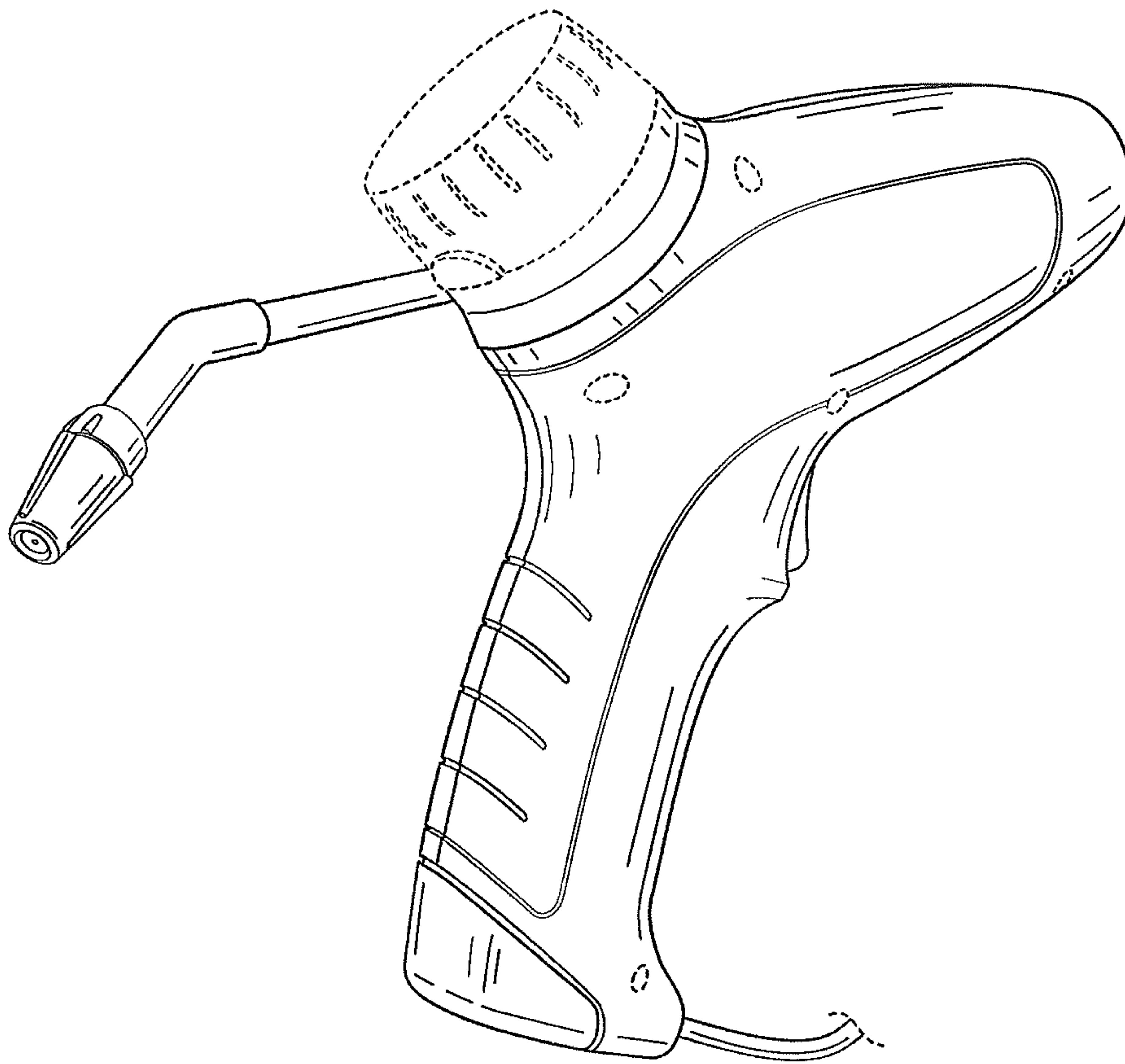

FIG. 2

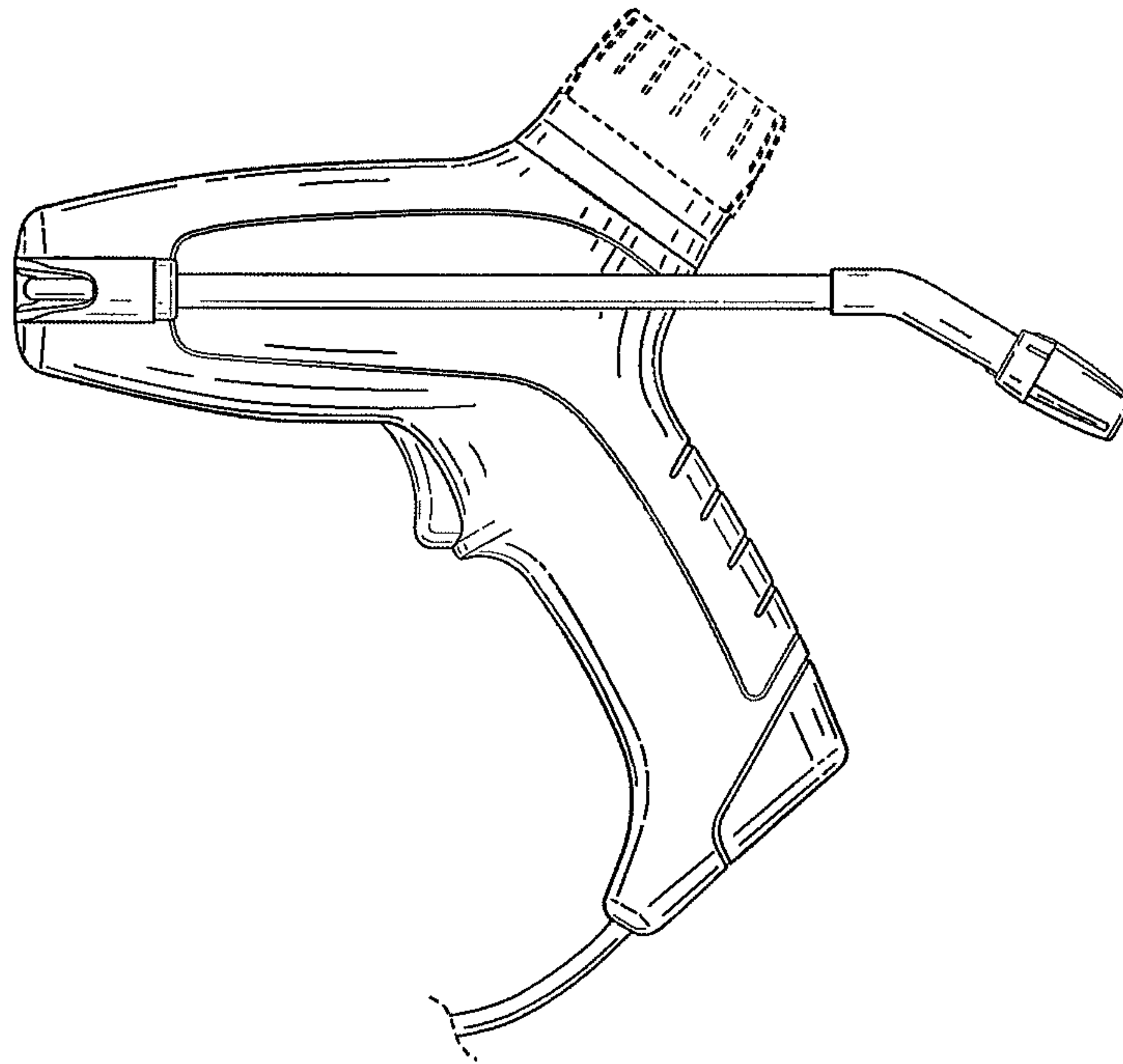

FIG. 3

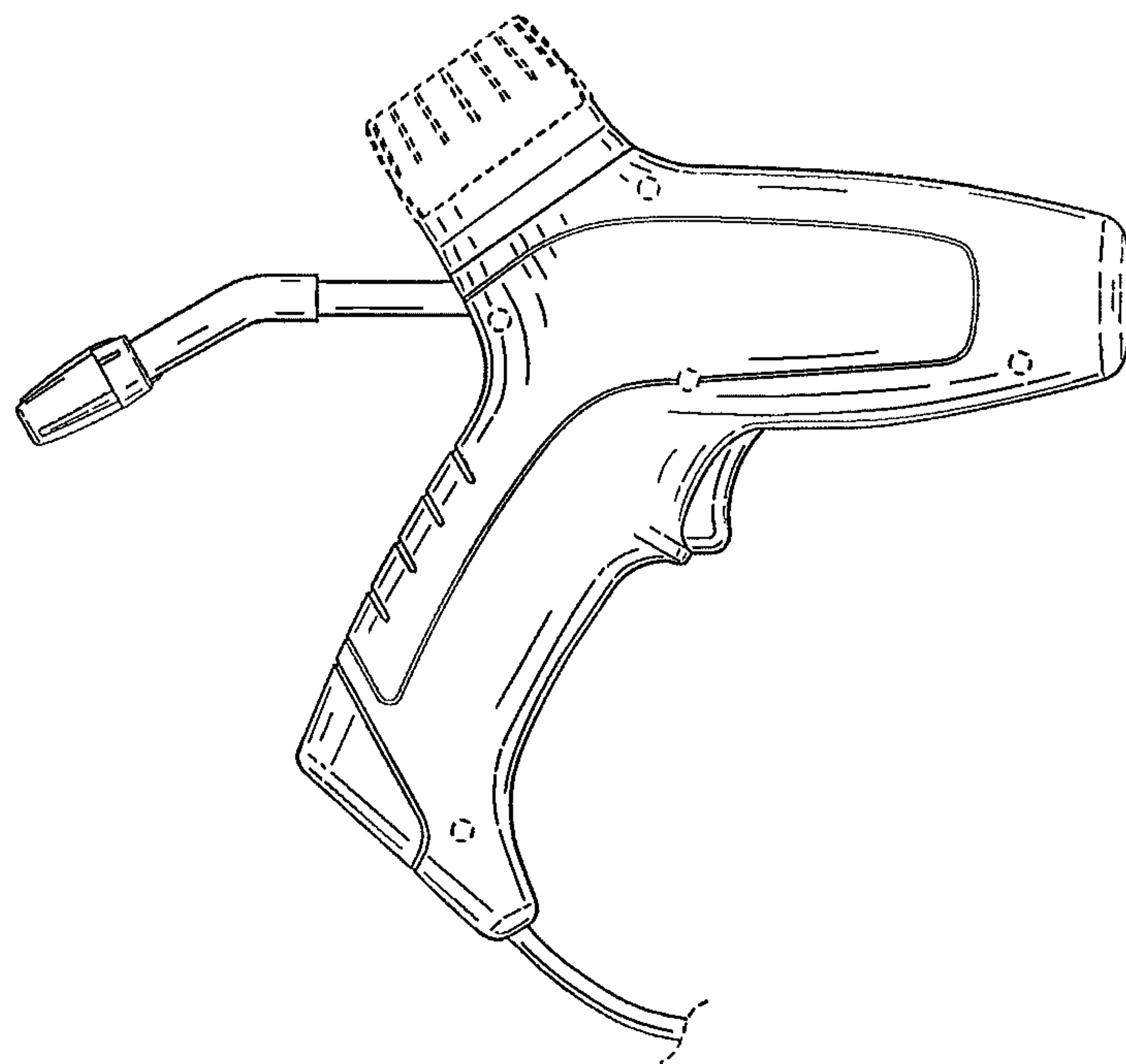

FIG. 4

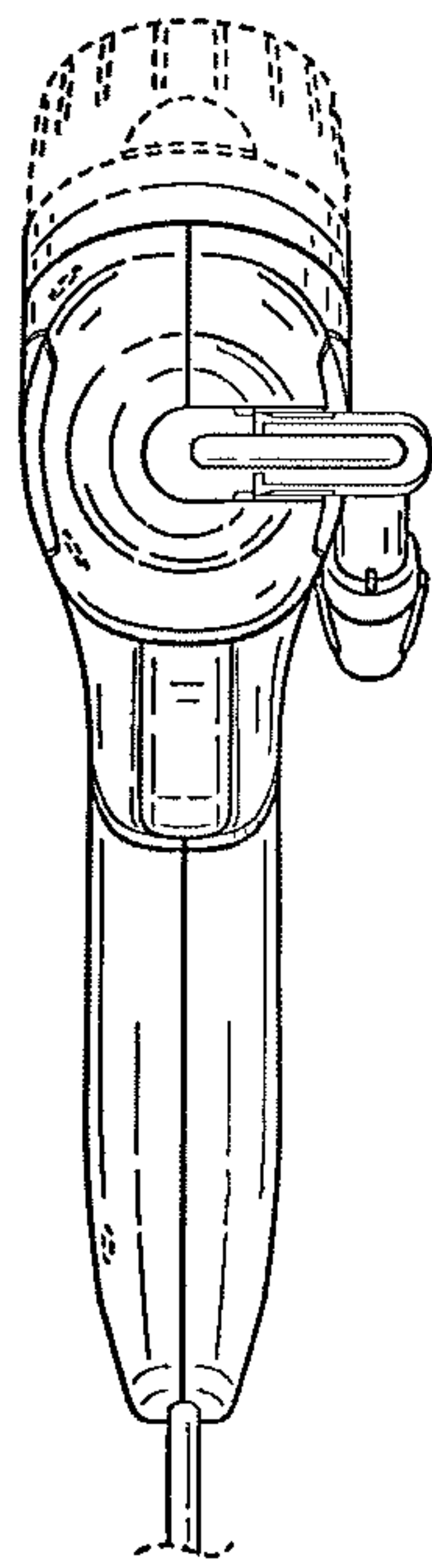

FIG. 5

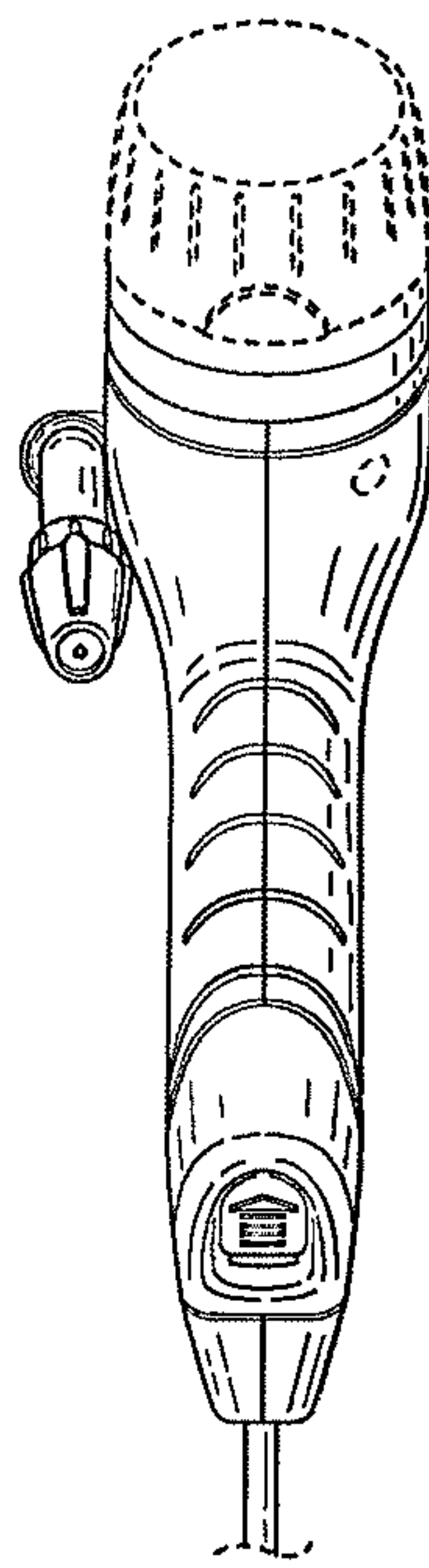

FIG. 6

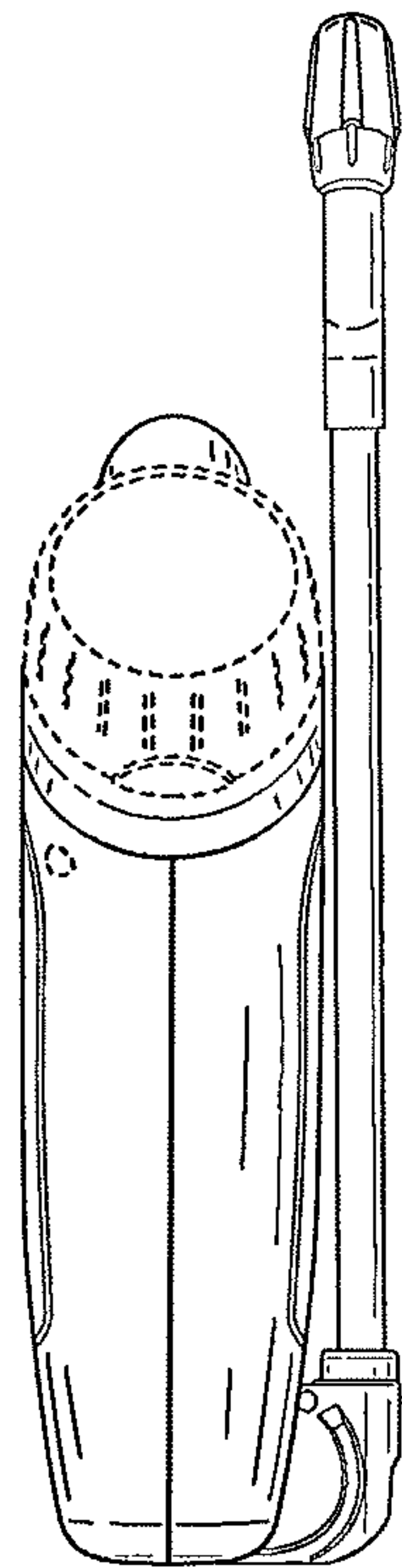

FIG. 7

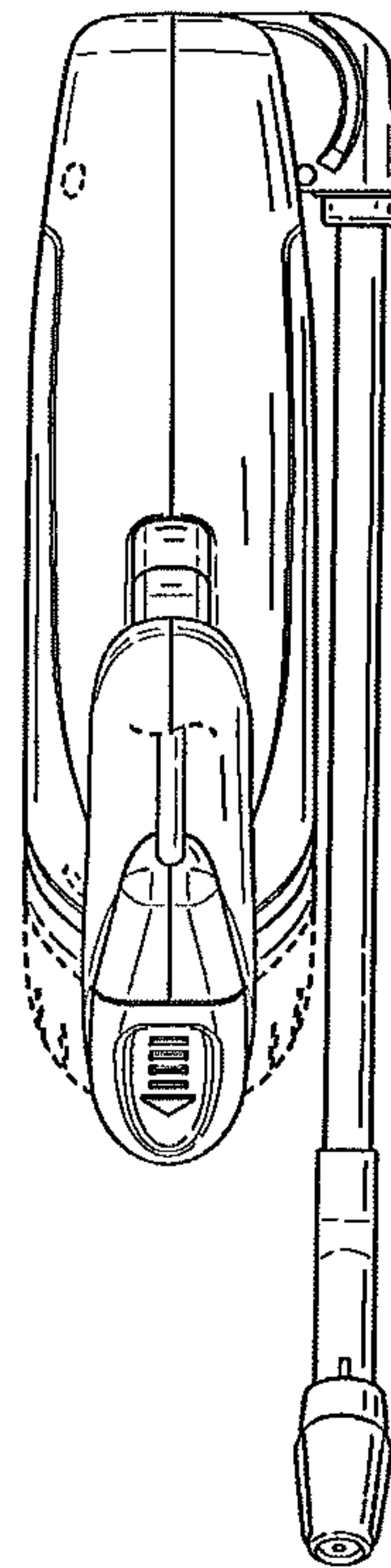

FIG. 8

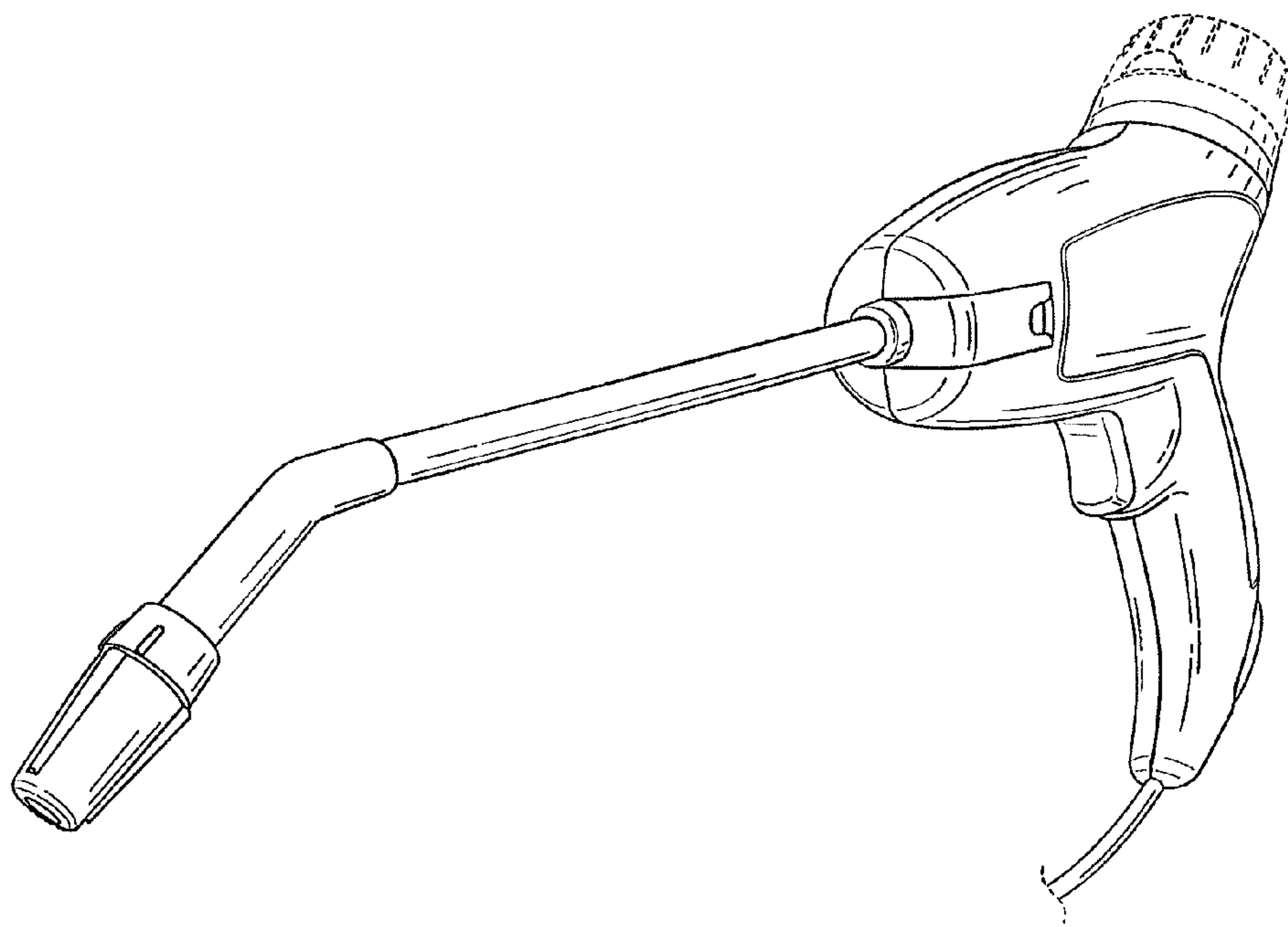

FIG. 9

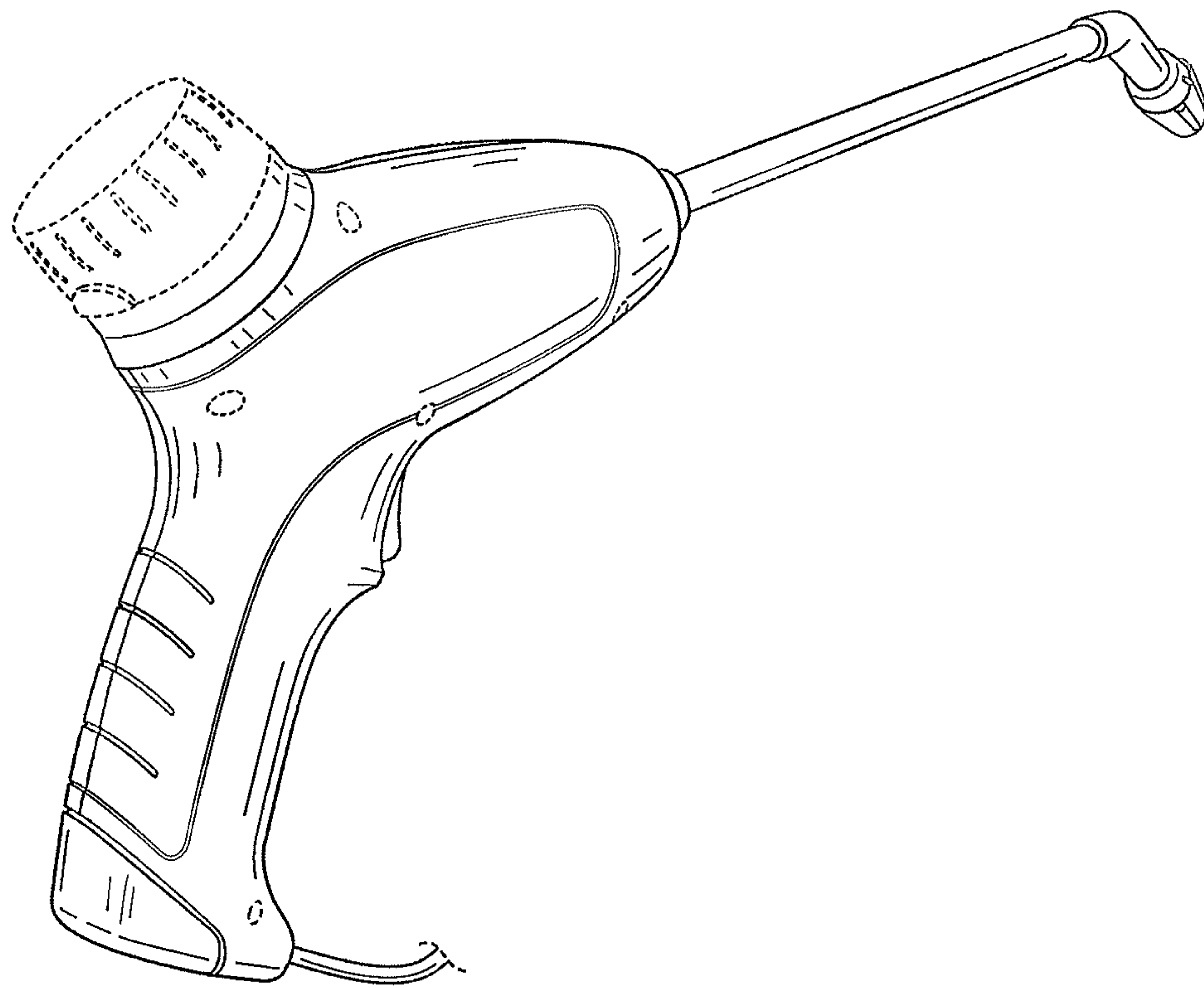

FIG. 10

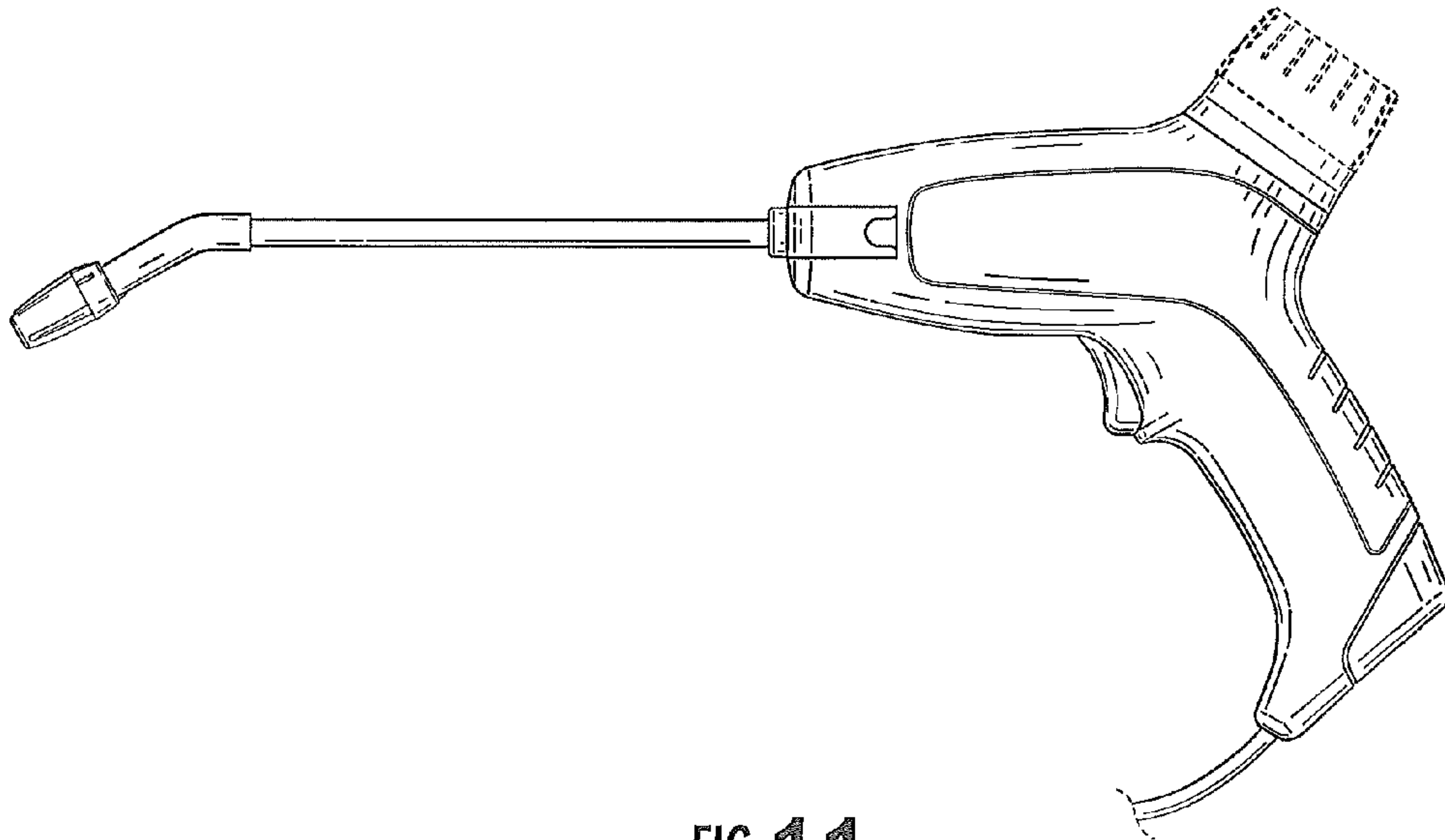

FIG. 11

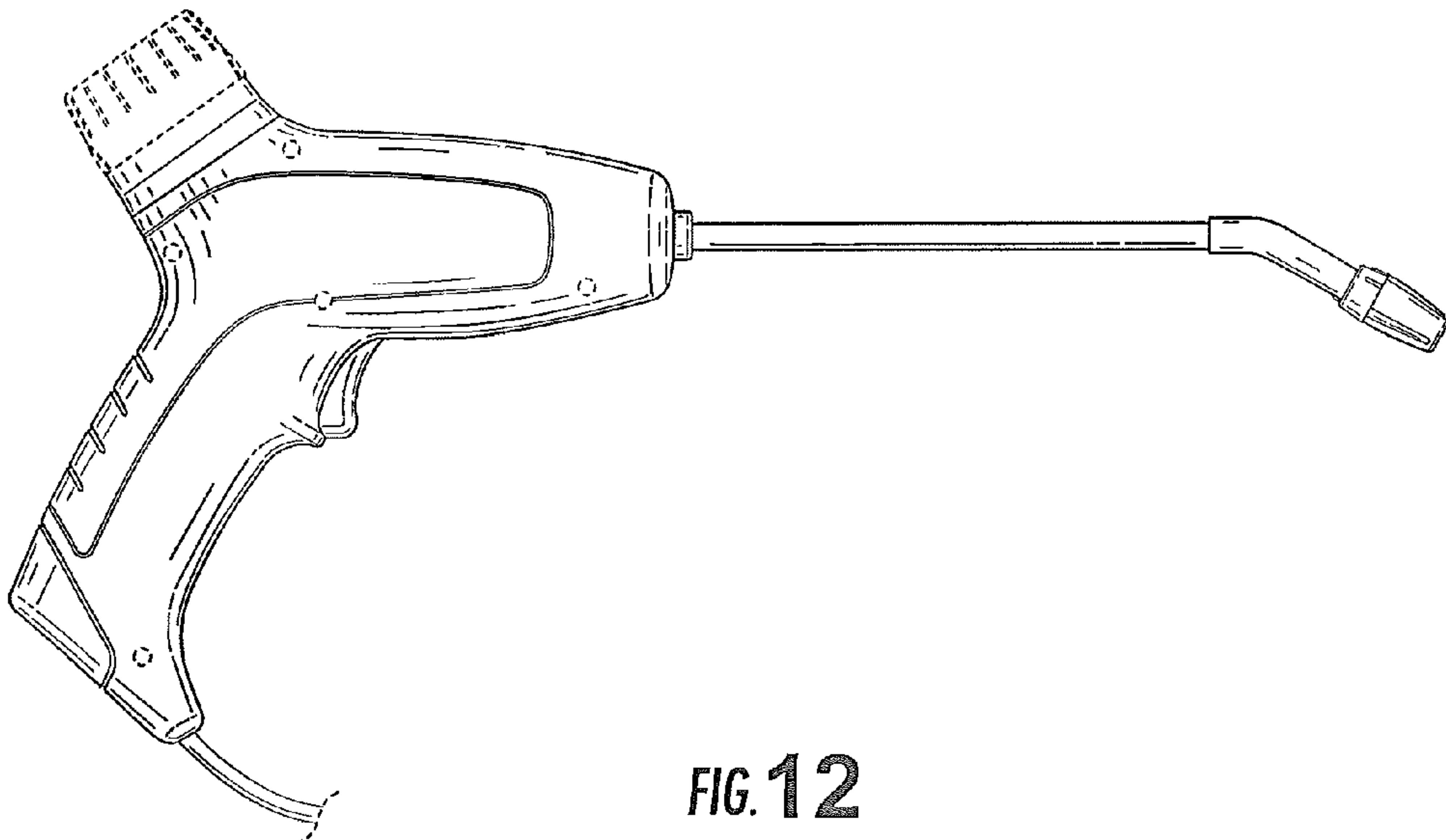

FIG. 12

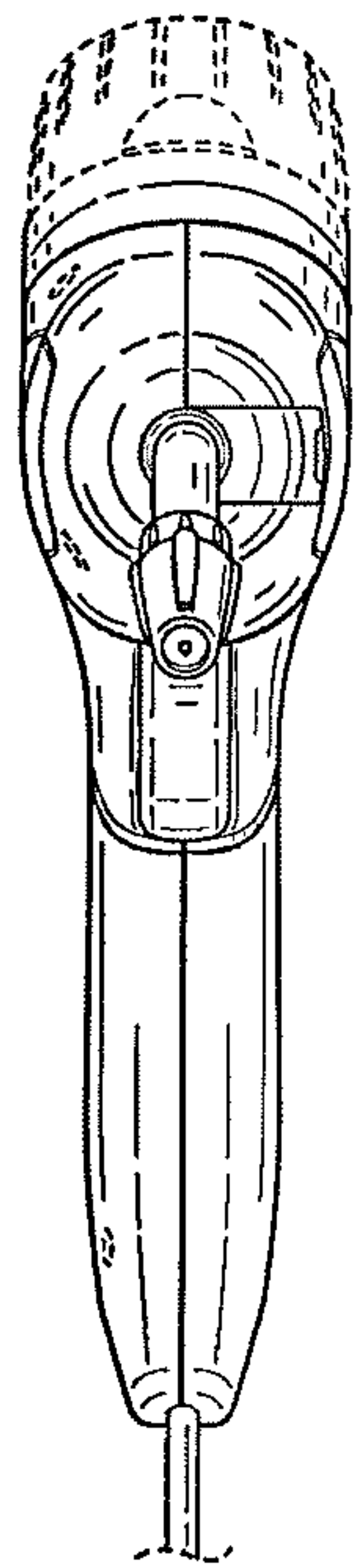

FIG. 13

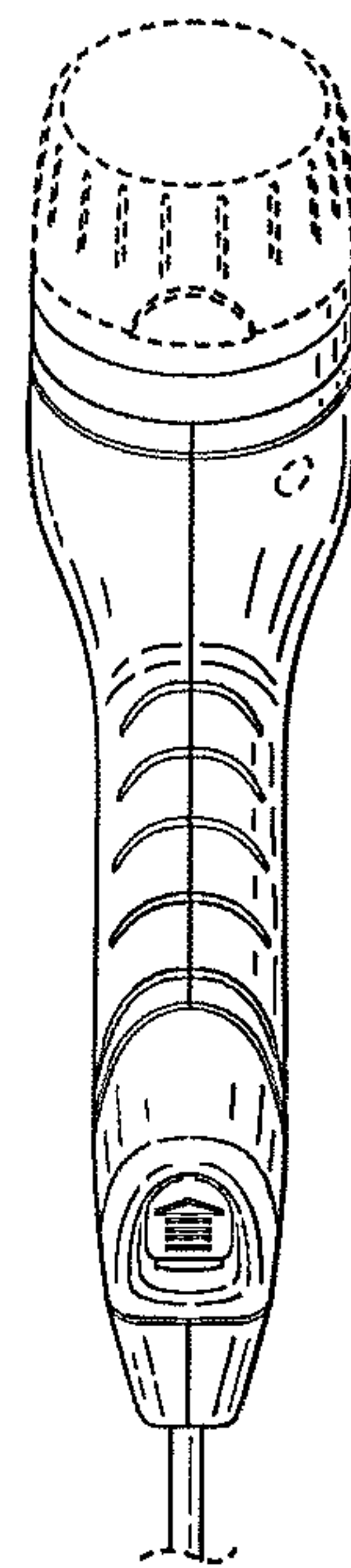

FIG. 14

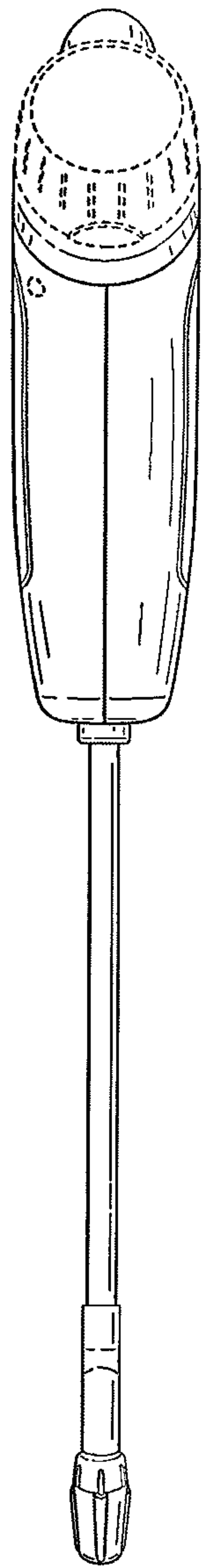

FIG. 15

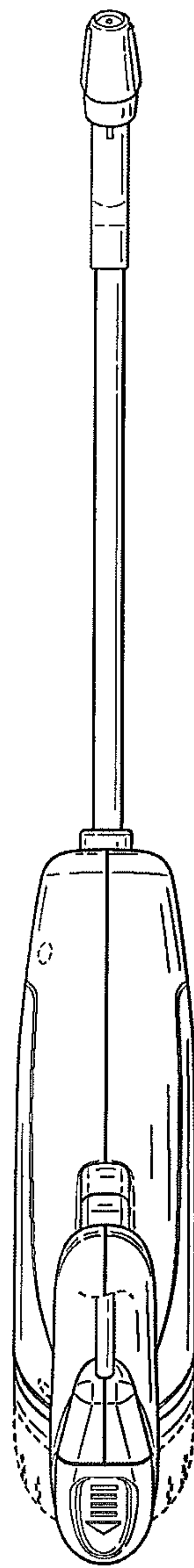

FIG. 16

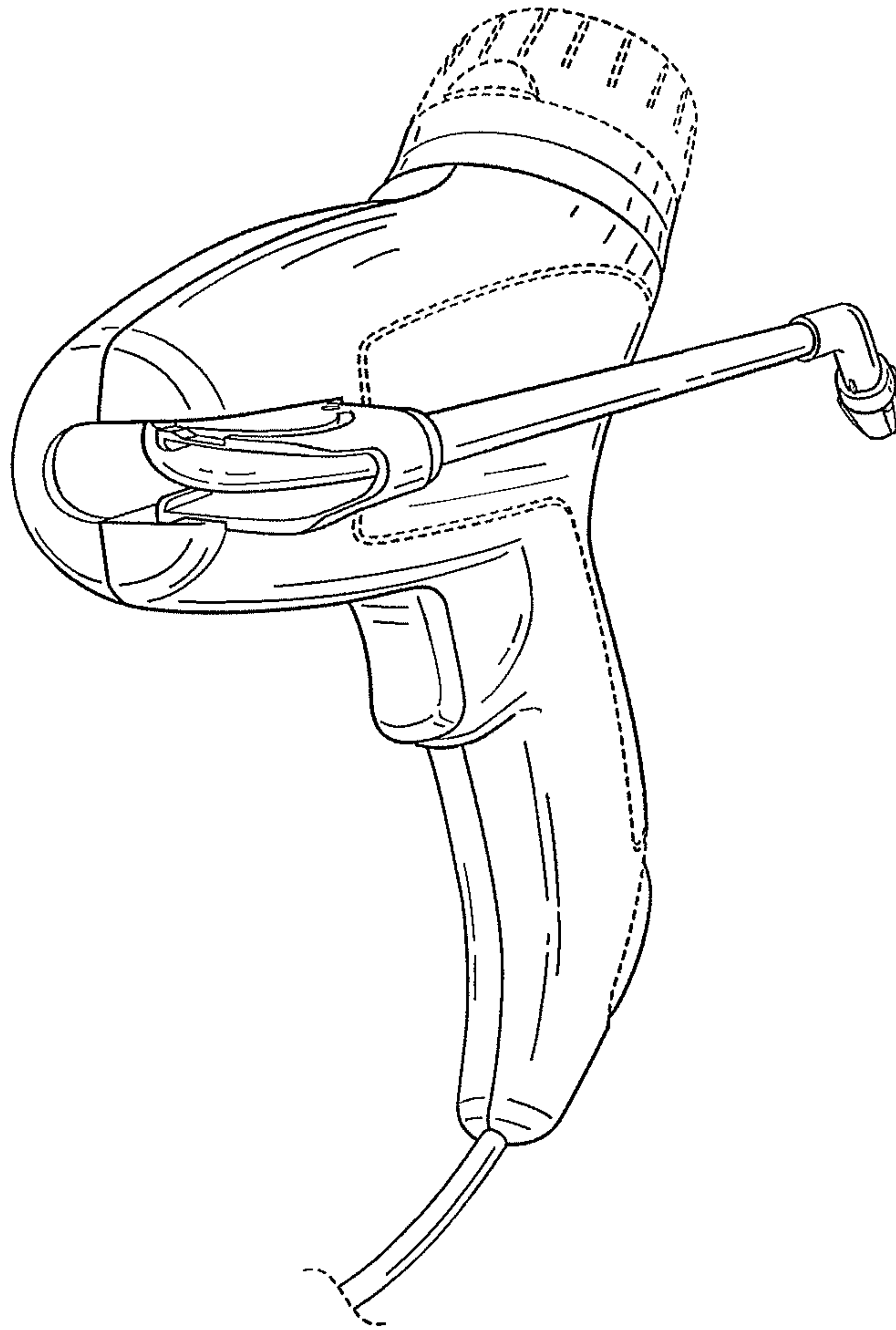

FIG. 17

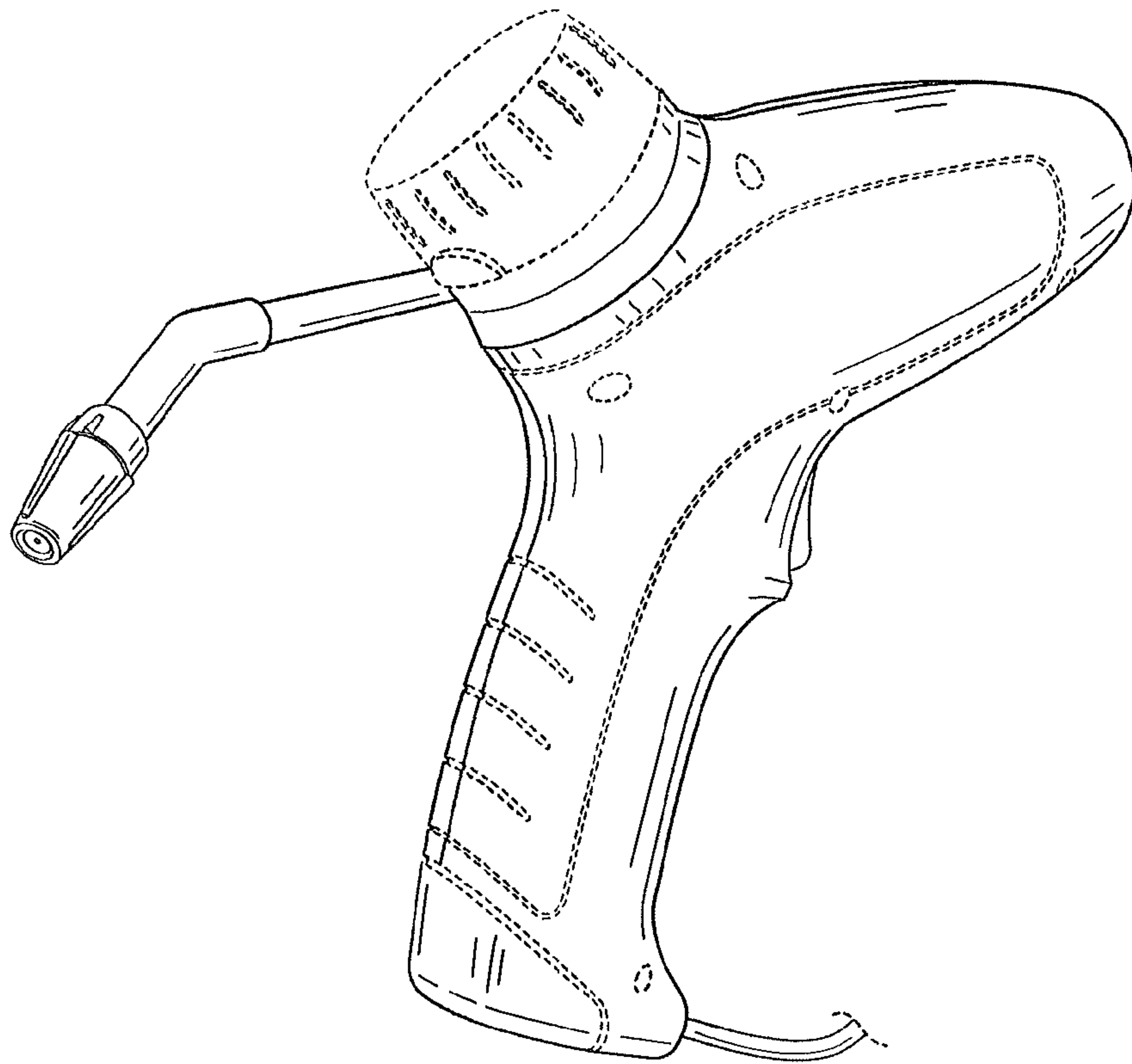

FIG. 18

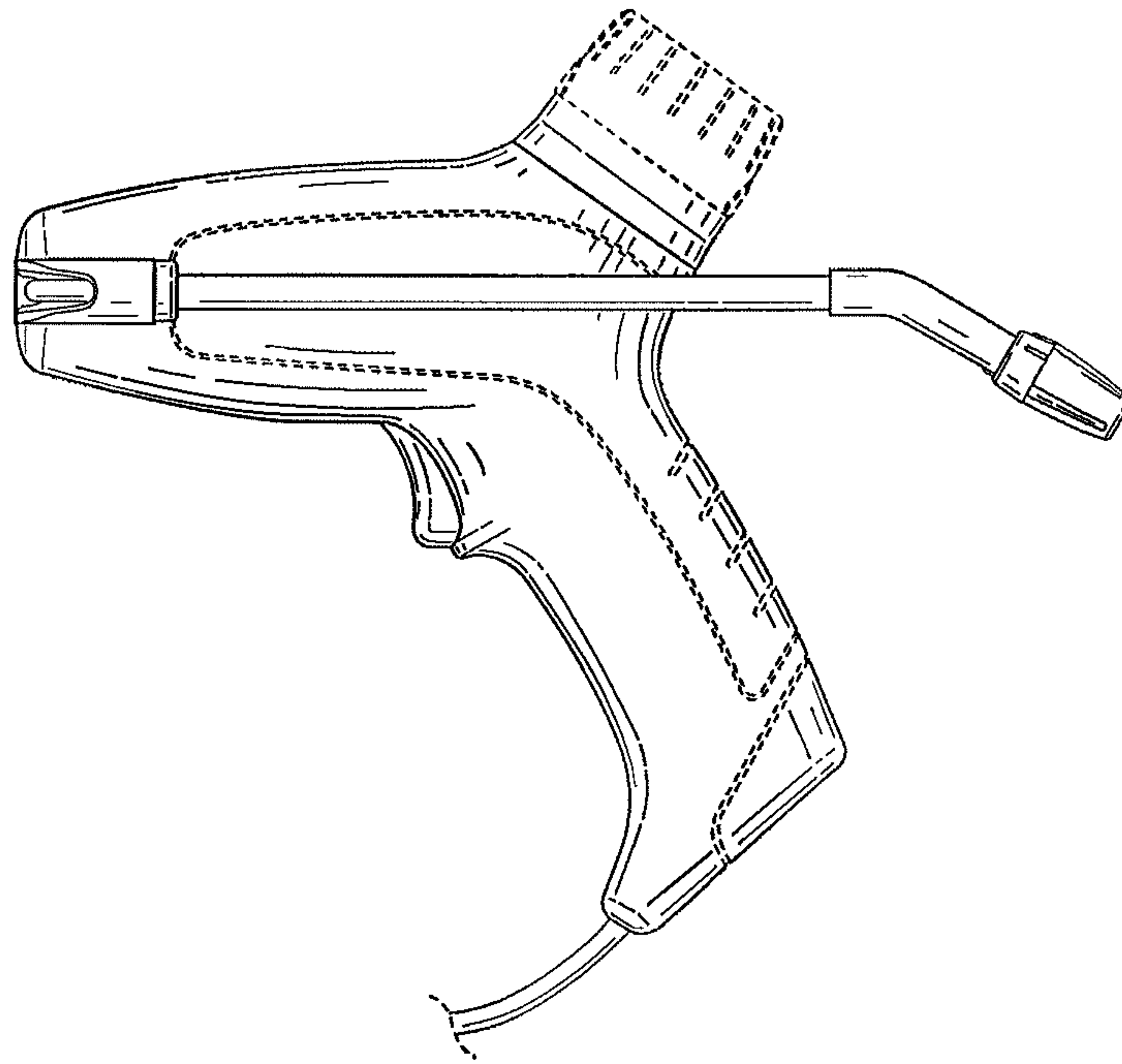

FIG. 19

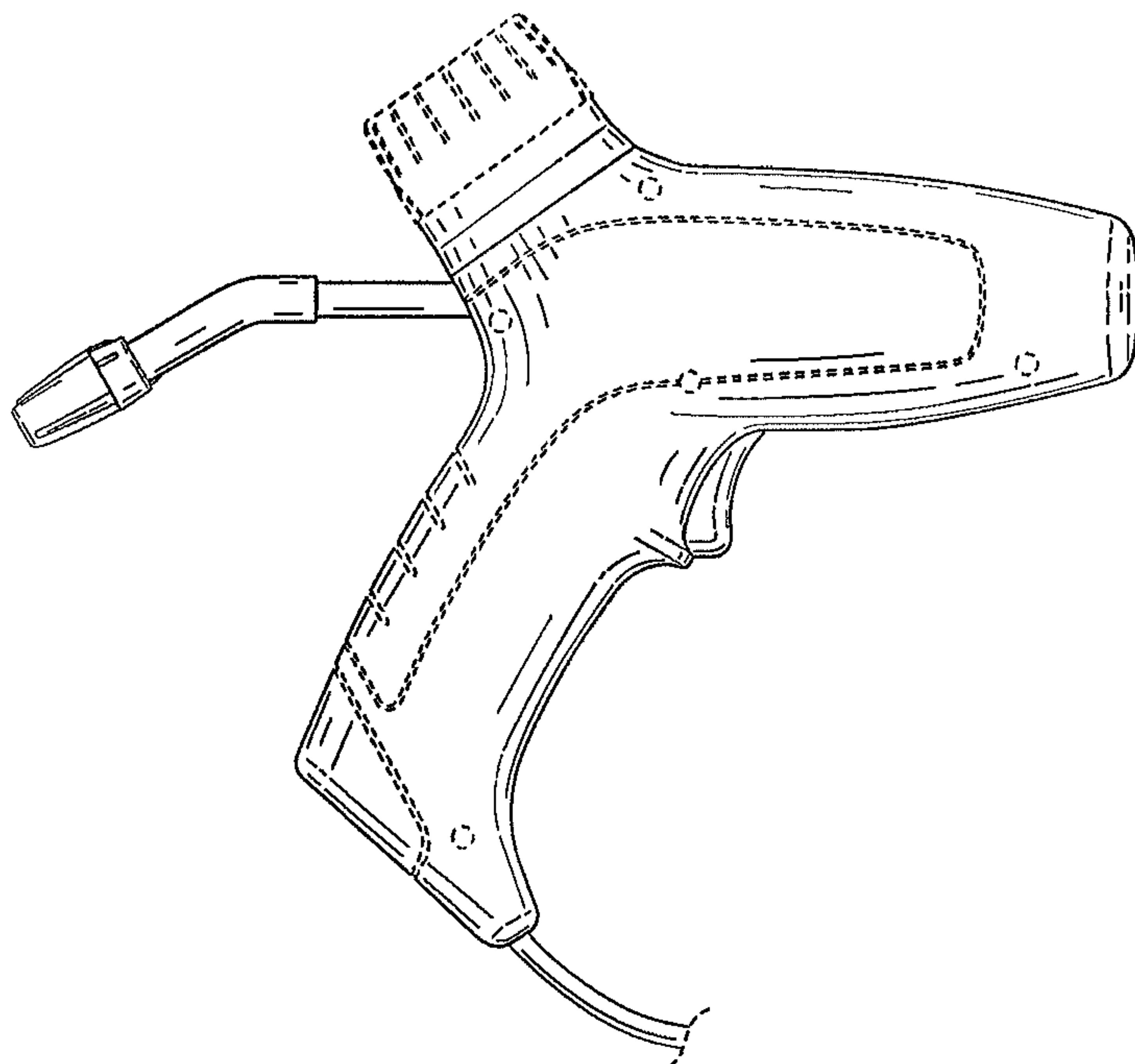

FIG. 20

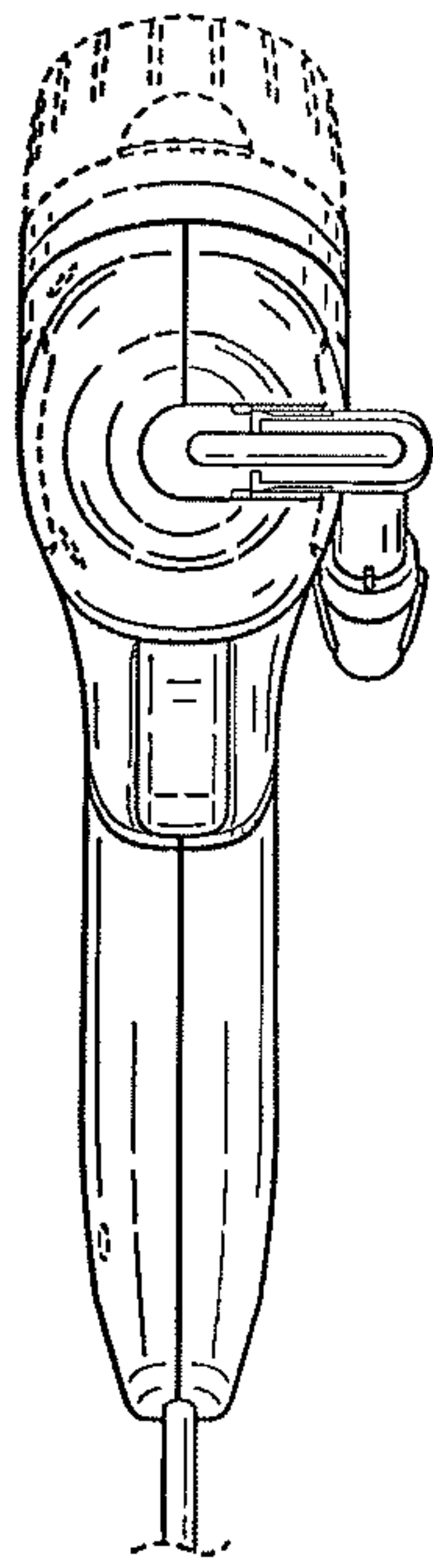

FIG. 21

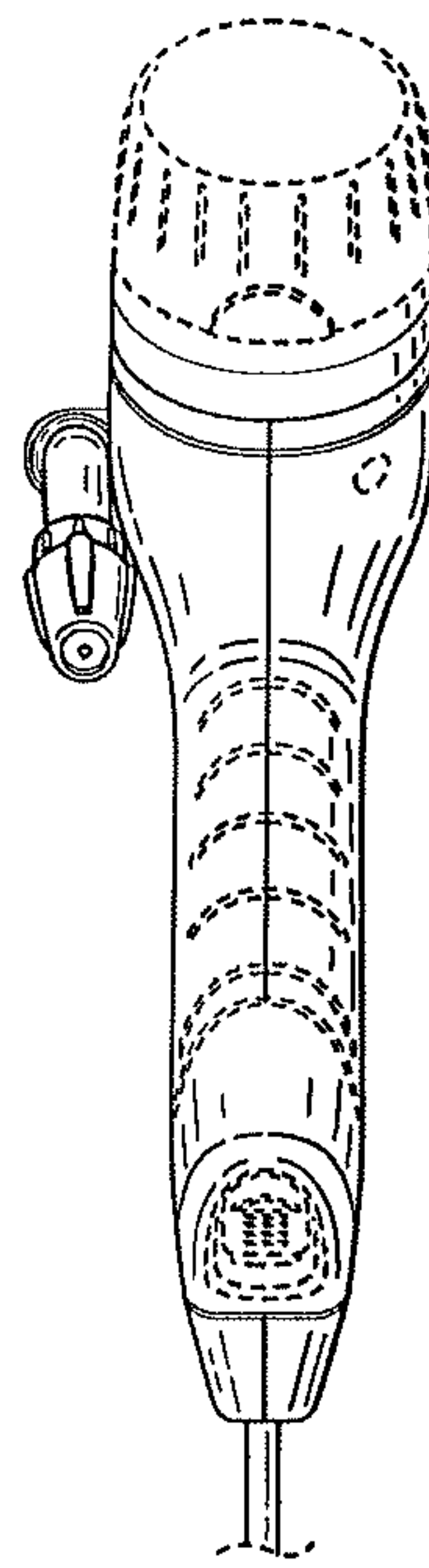

FIG. 22

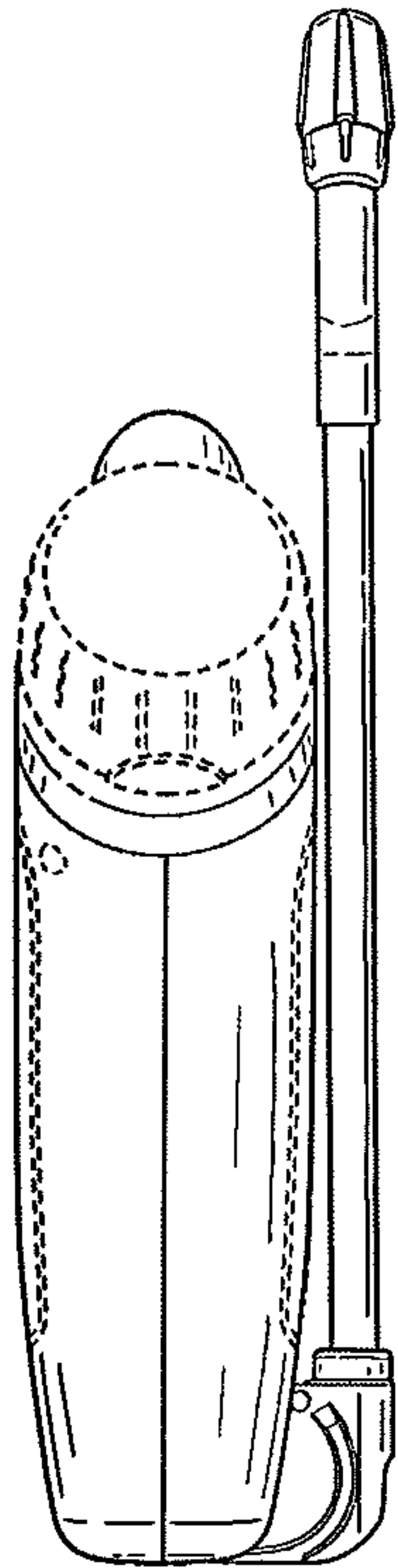

FIG. 23

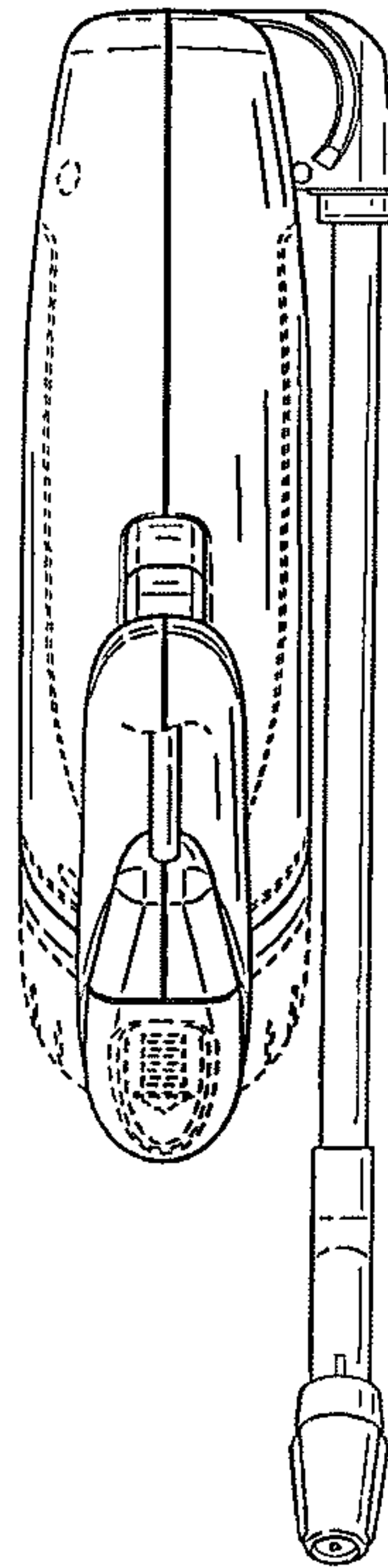

FIG. 24

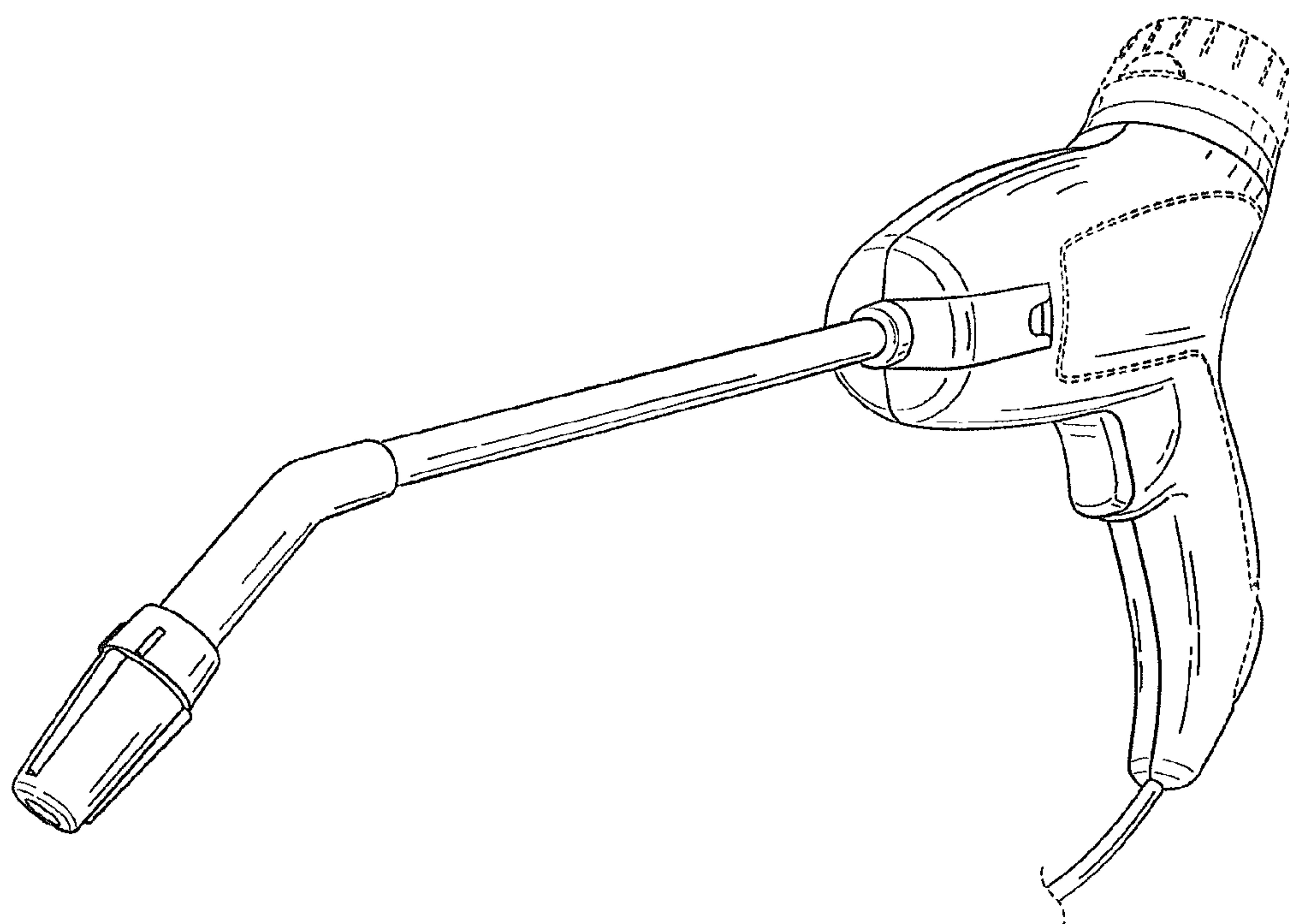

FIG. 25

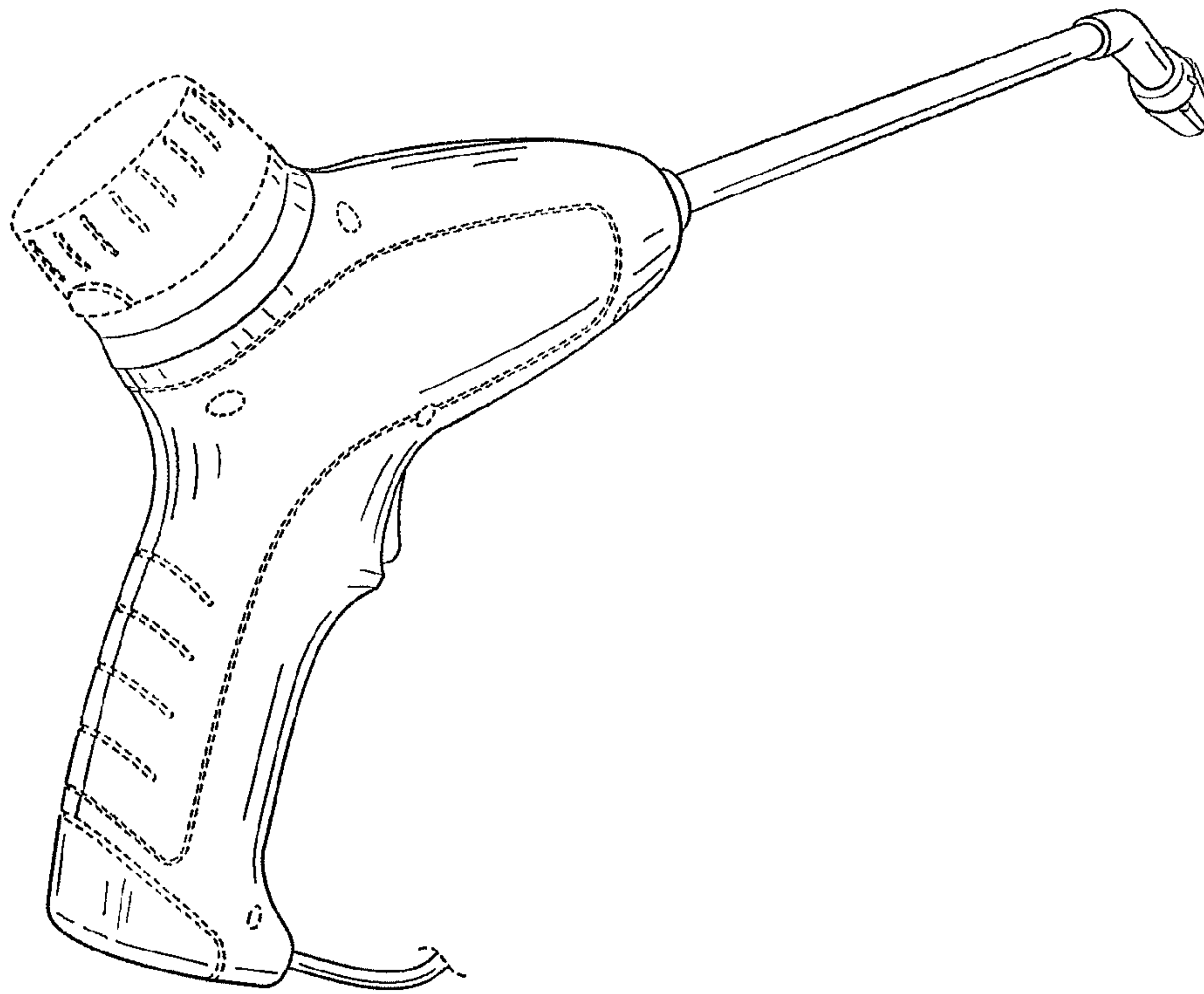

FIG. 26

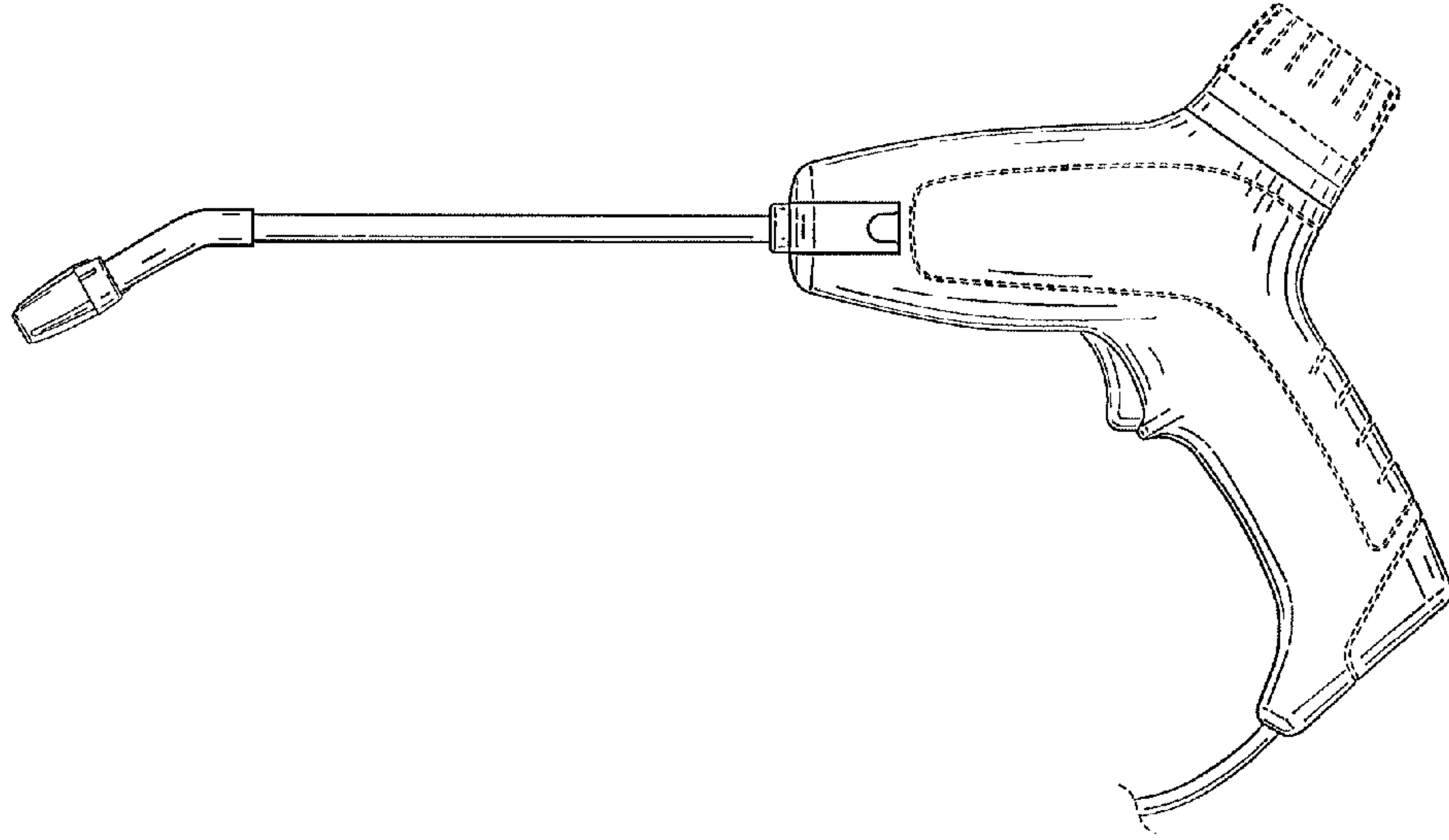

FIG. 27

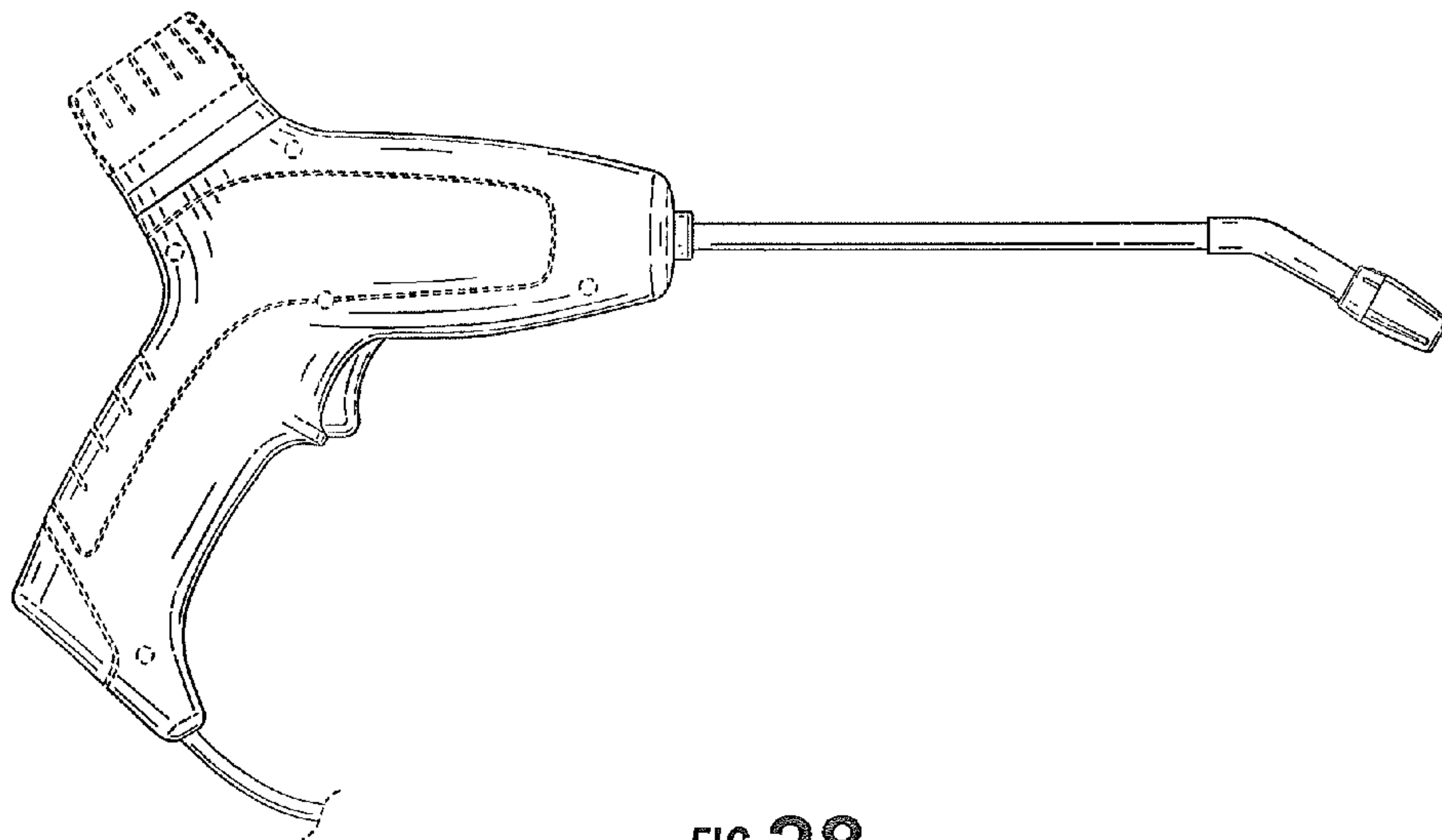

FIG. 28

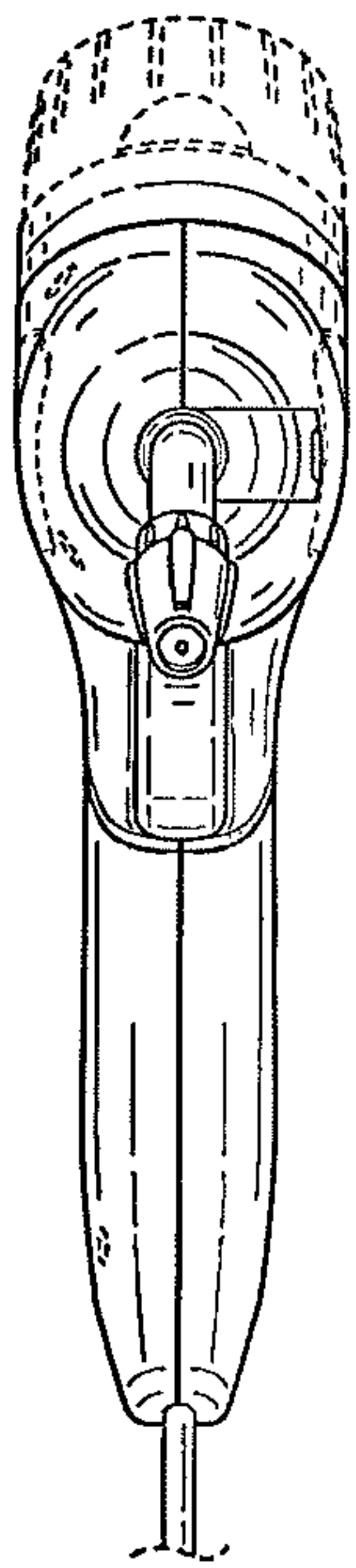

FIG. 29

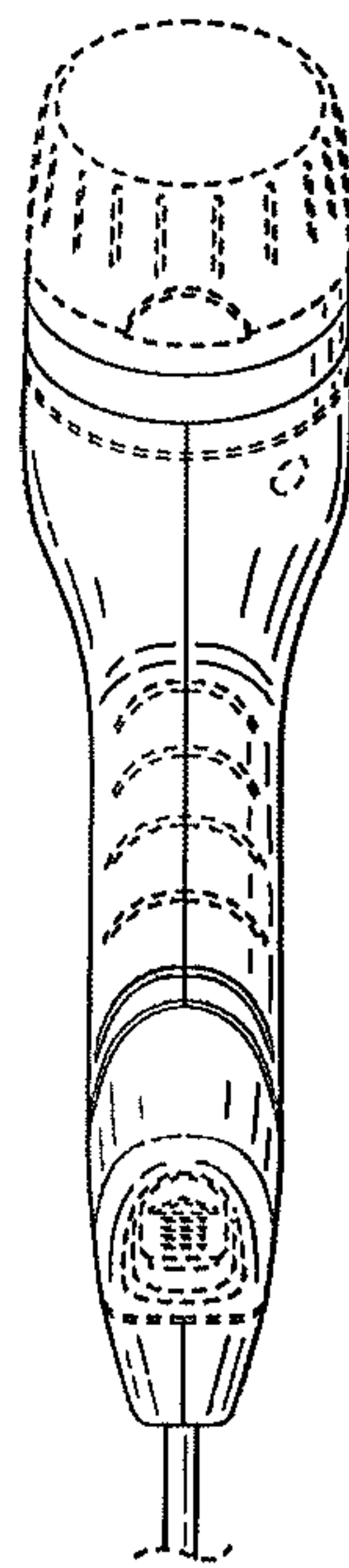

FIG. 30

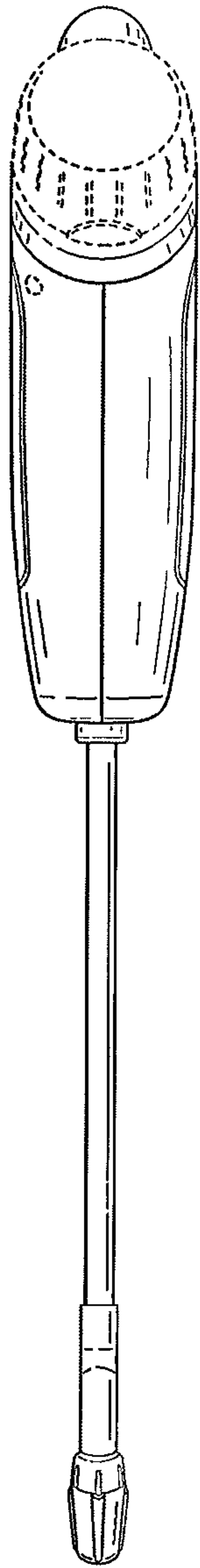

FIG. 31

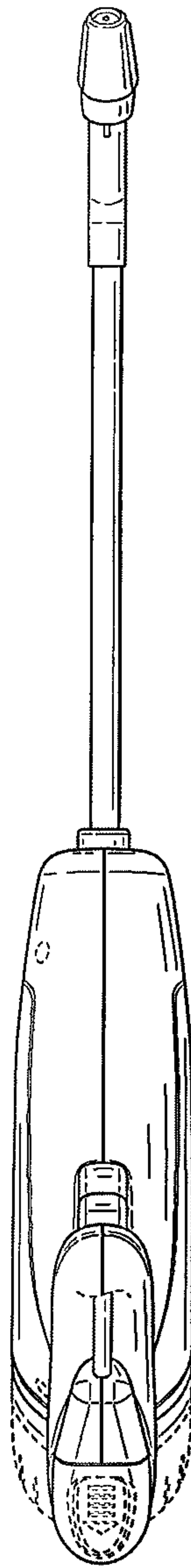

FIG. 32