



US00D713774S

(12) **United States Design Patent**
Tritschler et al.

(10) **Patent No.:** **US D713,774 S**

(45) **Date of Patent:** **** *Sep. 23, 2014**

(54) **AMPHIBIOUS SPORT AIRCRAFT WITH WINGS STOWED**

(71) Applicant: **ICON Aircraft, Inc.**, Los Angeles, CA (US)

(72) Inventors: **Klaus Tritschler**, Tehachapi, CA (US);
Steen Strand, Los Angeles, CA (US);
Jon Karkow, Tehachapi, CA (US)

(73) Assignee: **Icon Aircraft, Inc.**, Los Angeles, CA (US)

(*) Notice: This patent is subject to a terminal disclaimer.

(**) Term: **14 Years**

(21) Appl. No.: **29/460,807**

(22) Filed: **Jul. 15, 2013**

(51) **LOC (10) Cl.** **12-07**

(52) **U.S. Cl.**
USPC **D12/324**; D12/3; D12/339

(58) **Field of Classification Search**
USPC D12/2, 3, 4, 16.1, 319, 324, 326-334,
D12/337, 338, 339, 341, 344, 345;
D21/430, 436, 441, 442, 446-450, 451,
D21/452, 453; 244/2, 5, 6, 7 R, 7 A, 7 C, 8,
244/13, 55, 56, 101, 105, 106, 120, 125,
244/17.19; 280/1.12, 1.21; 446/34-38,
446/57-59, 230-236

See application file for complete search history.

(56) **References Cited**

U.S. PATENT DOCUMENTS

D137,661	S	*	4/1944	Sheffield	D12/344
D178,584	S	*	8/1956	Toth	D12/324
4,121,791	A	*	10/1978	Taylor et al.	244/120
4,962,978	A	*	10/1990	Weston	244/105
D325,021	S	*	3/1992	Mouton, Jr.	D12/324
D392,937	S	*	3/1998	Brichard et al.	D12/324
5,913,493	A	*	6/1999	Labouchere	244/105
6,113,028	A	*	9/2000	Lohse et al.	244/13
D613,202	S	*	4/2010	Rodriguez et al.	D12/3
D620,392	S	*	7/2010	Rodriguez et al.	D12/3
D620,838	S	*	8/2010	Miralles et al.	D12/3
8,177,162	B2	*	5/2012	Karkow et al.	244/105
2006/0255208	A1	*	11/2006	Hawkins	244/105

* cited by examiner

Primary Examiner — Martie K Holtje

(74) *Attorney, Agent, or Firm* — Martensen IP

(57) **CLAIM**

The ornamental design for an amphibious sport aircraft with wings stowed, as shown and described.

DESCRIPTION

FIG. 1 is a right front perspective view of an amphibious sport aircraft with wings stowed showing our new design;
FIG. 2 is a front elevational view thereof;
FIG. 3 is a rear elevational view thereof;
FIG. 4 is a right side elevational view thereof;
FIG. 5 is a left side elevational view thereof;
FIG. 6 is a top plan view thereof; and,
FIG. 7 is a bottom plan view thereof.

The structural elements depicted by broken lines have been shown for the purpose of illustrating portions of the amphibious sport aircraft with wings stowed that form no part of the claimed design.

1 Claim, 5 Drawing Sheets

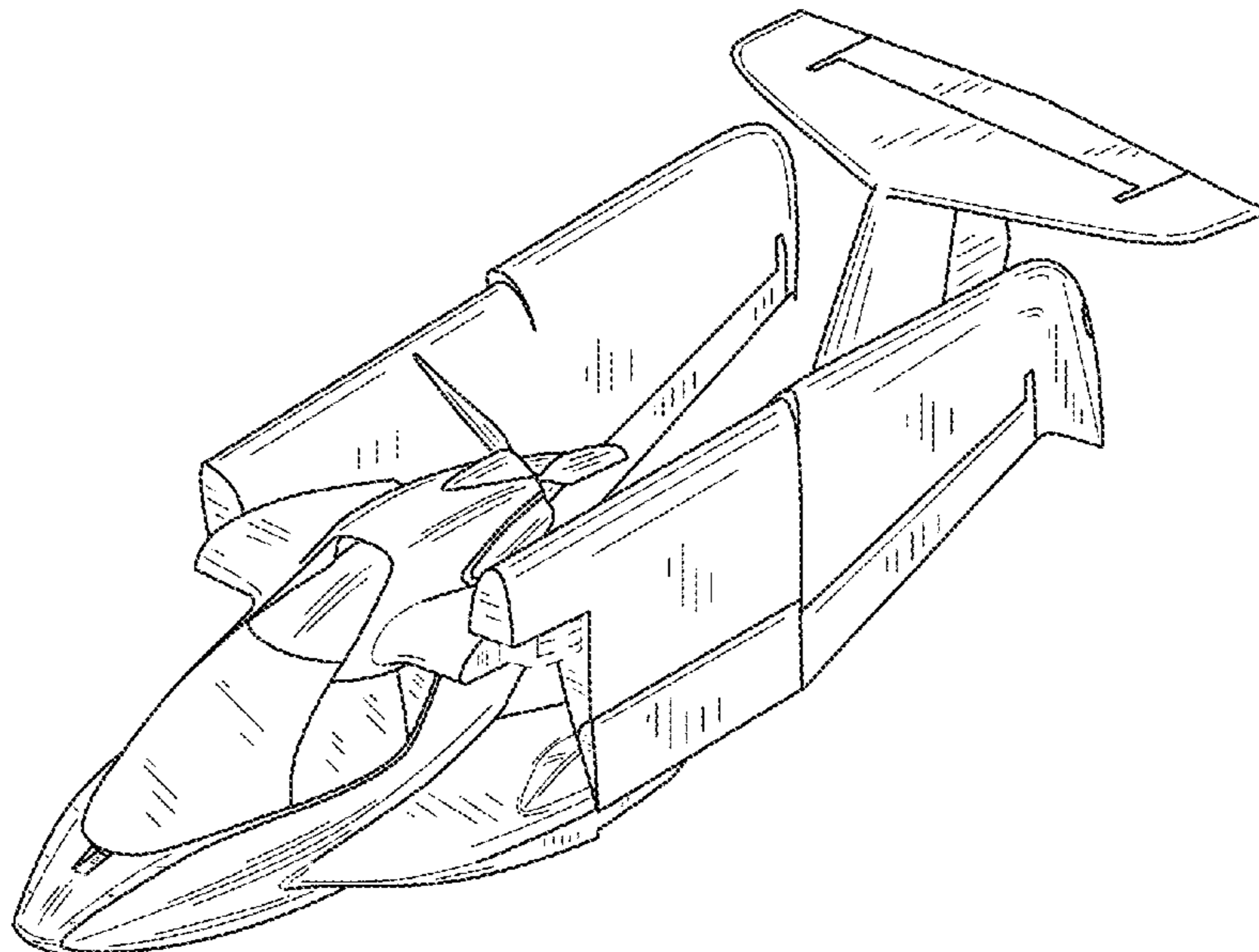

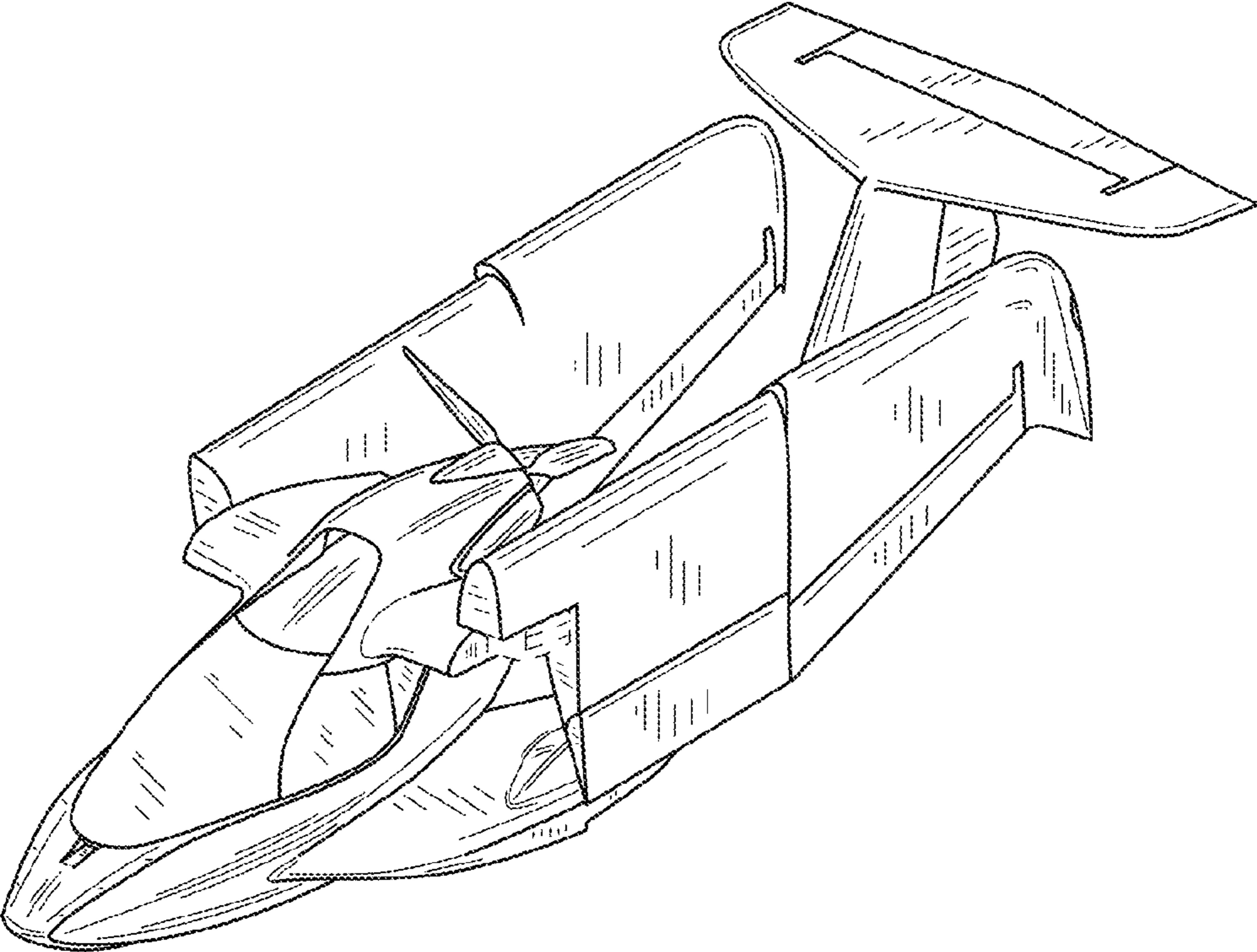

FIG.1

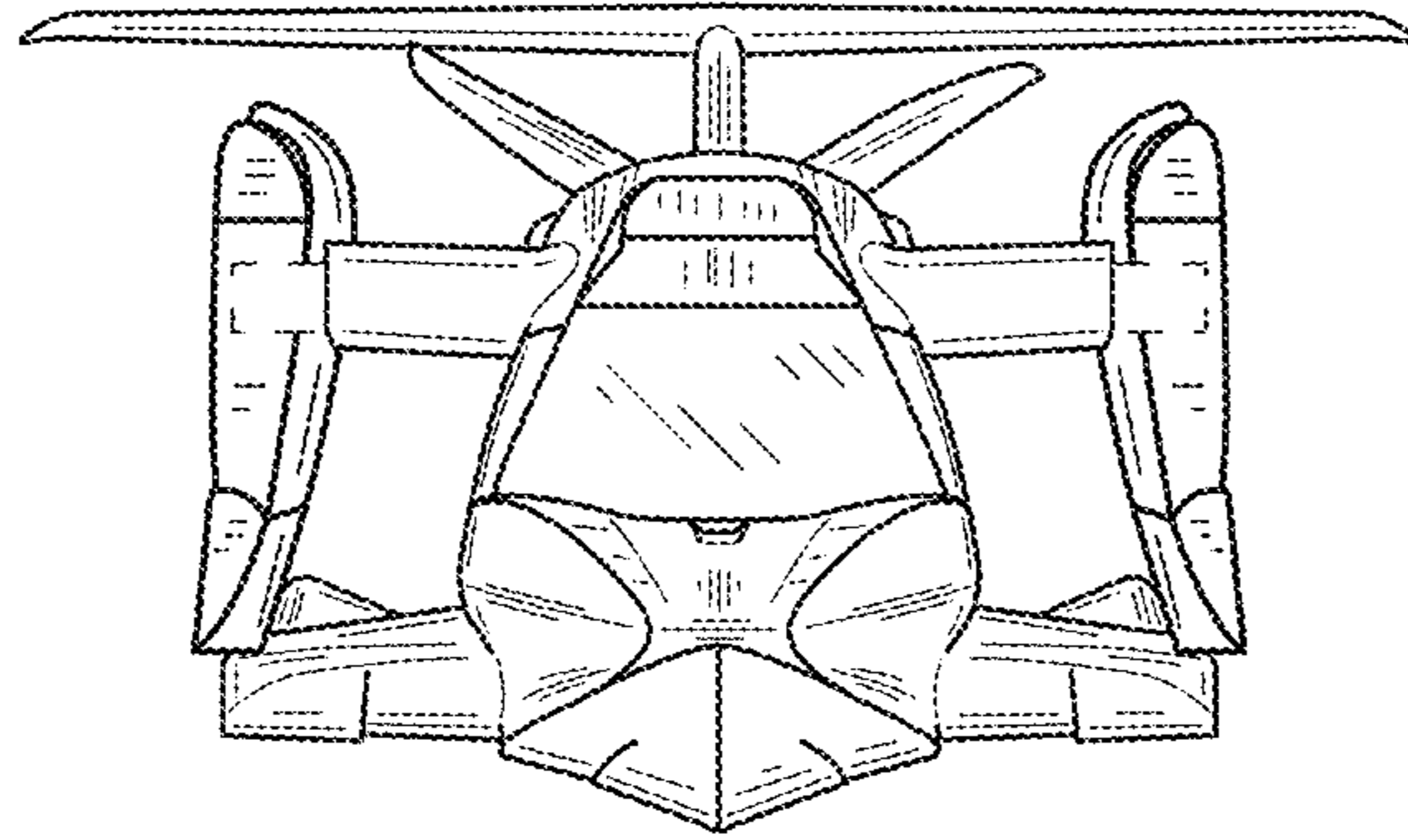

FIG. 2

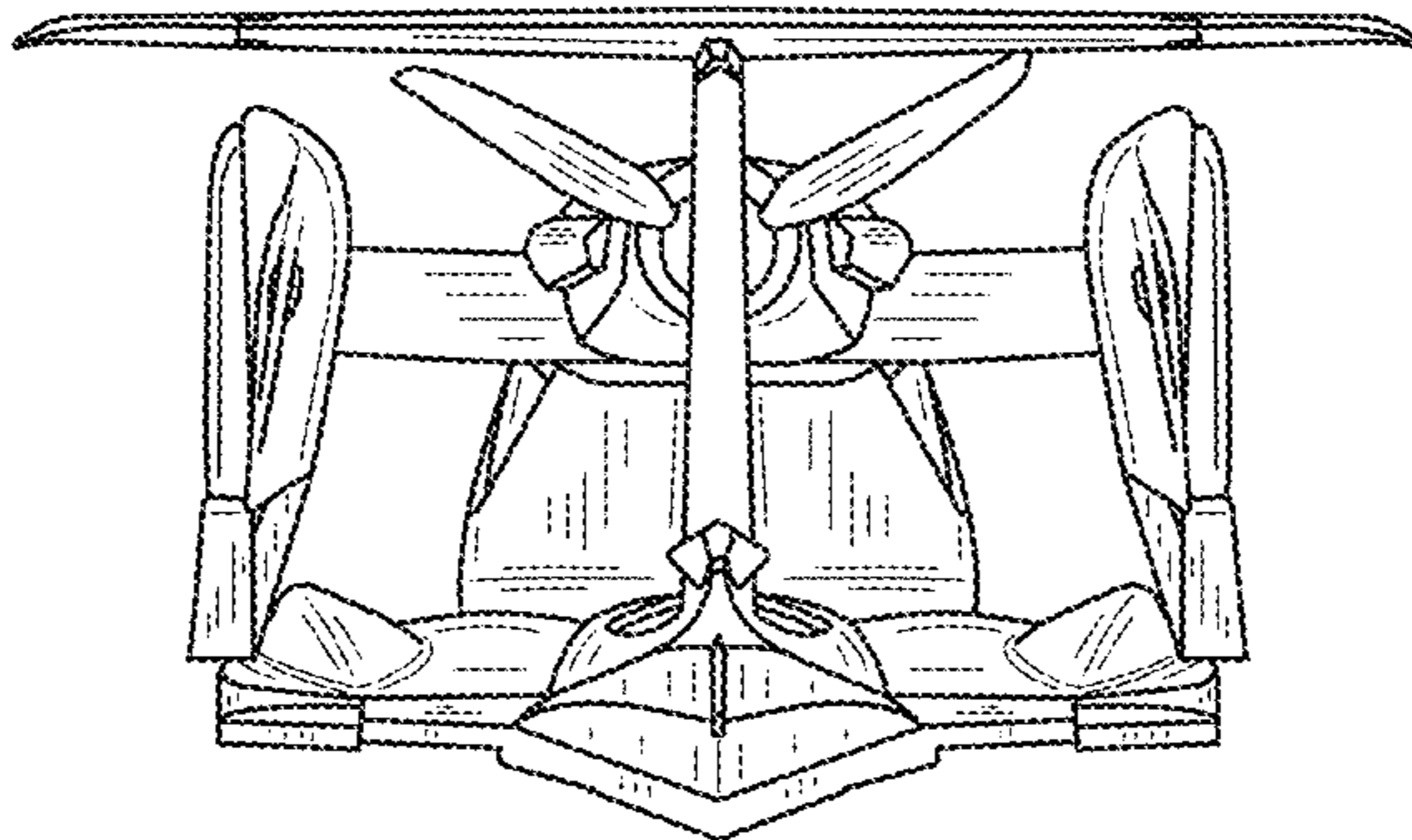

FIG. 3

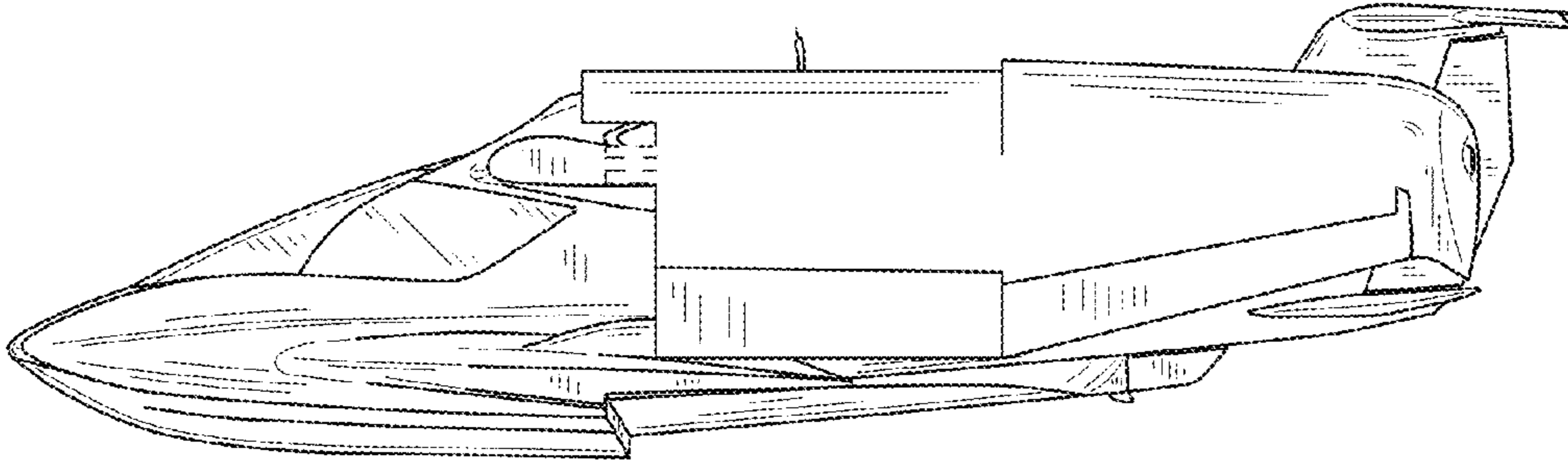

FIG.4

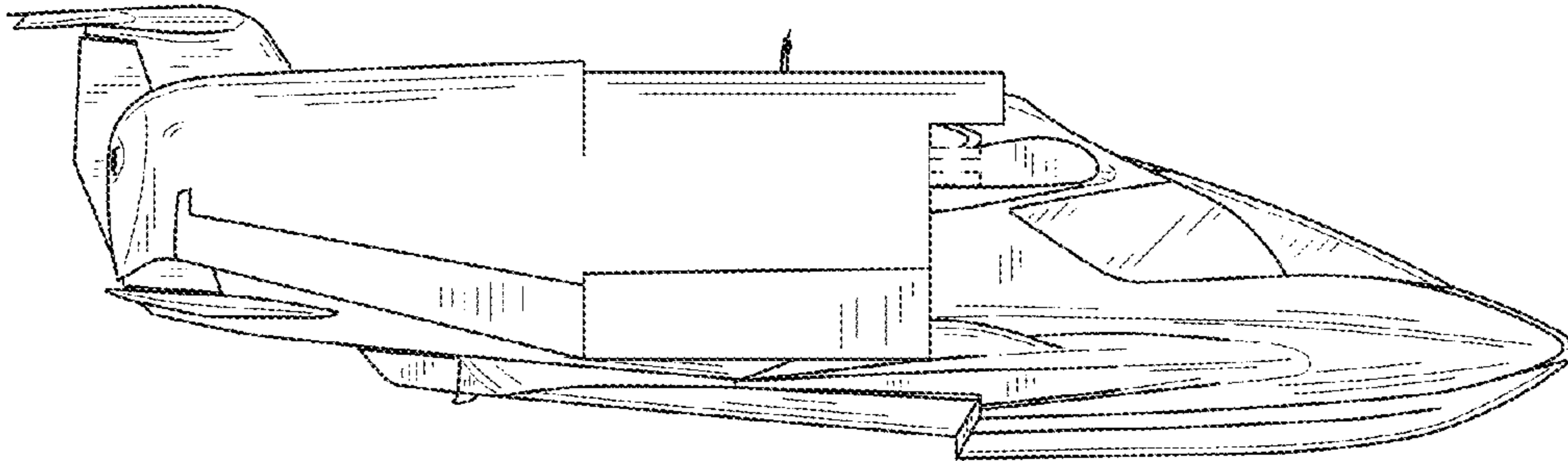

FIG.5

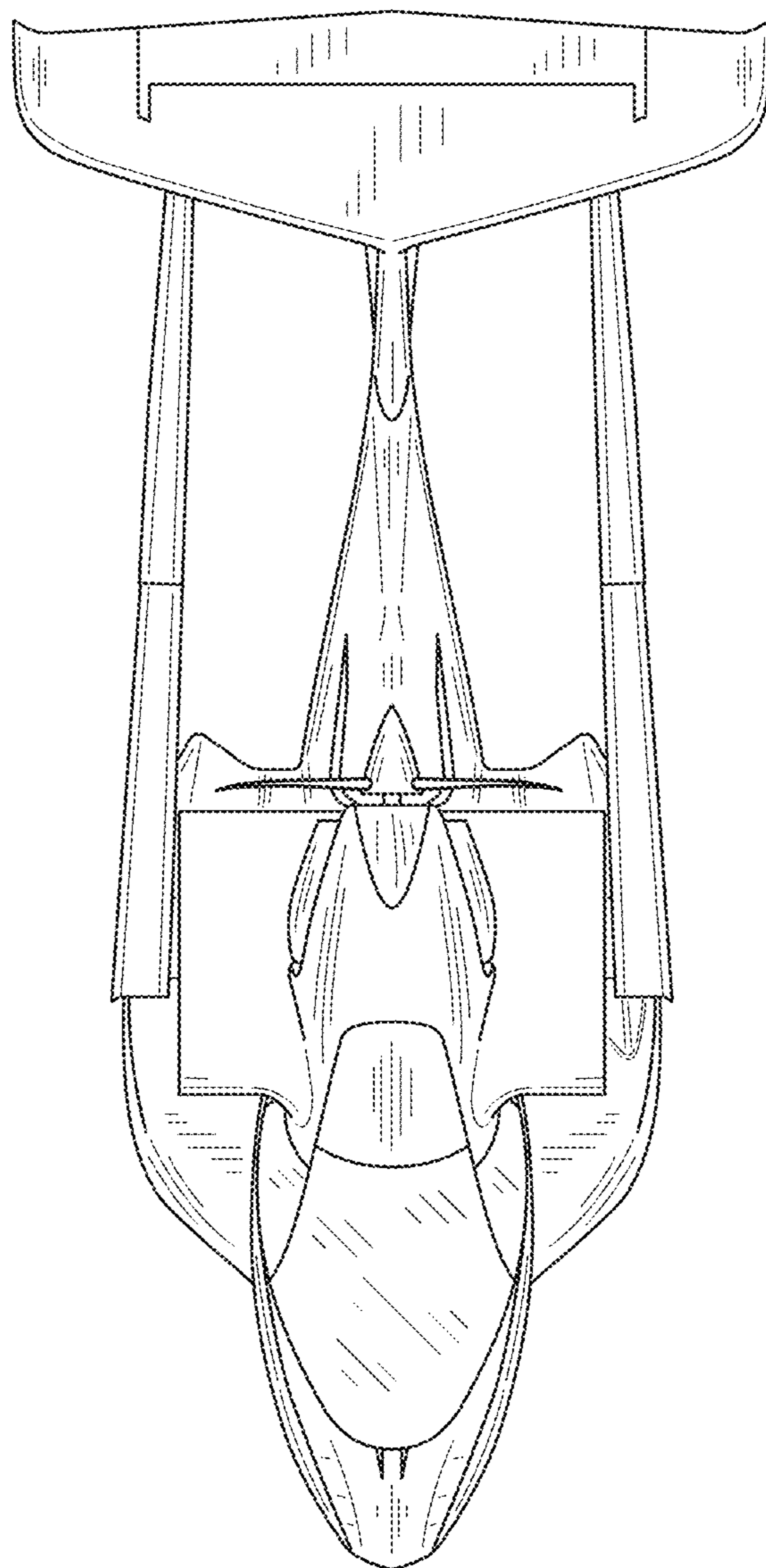

FIG.6

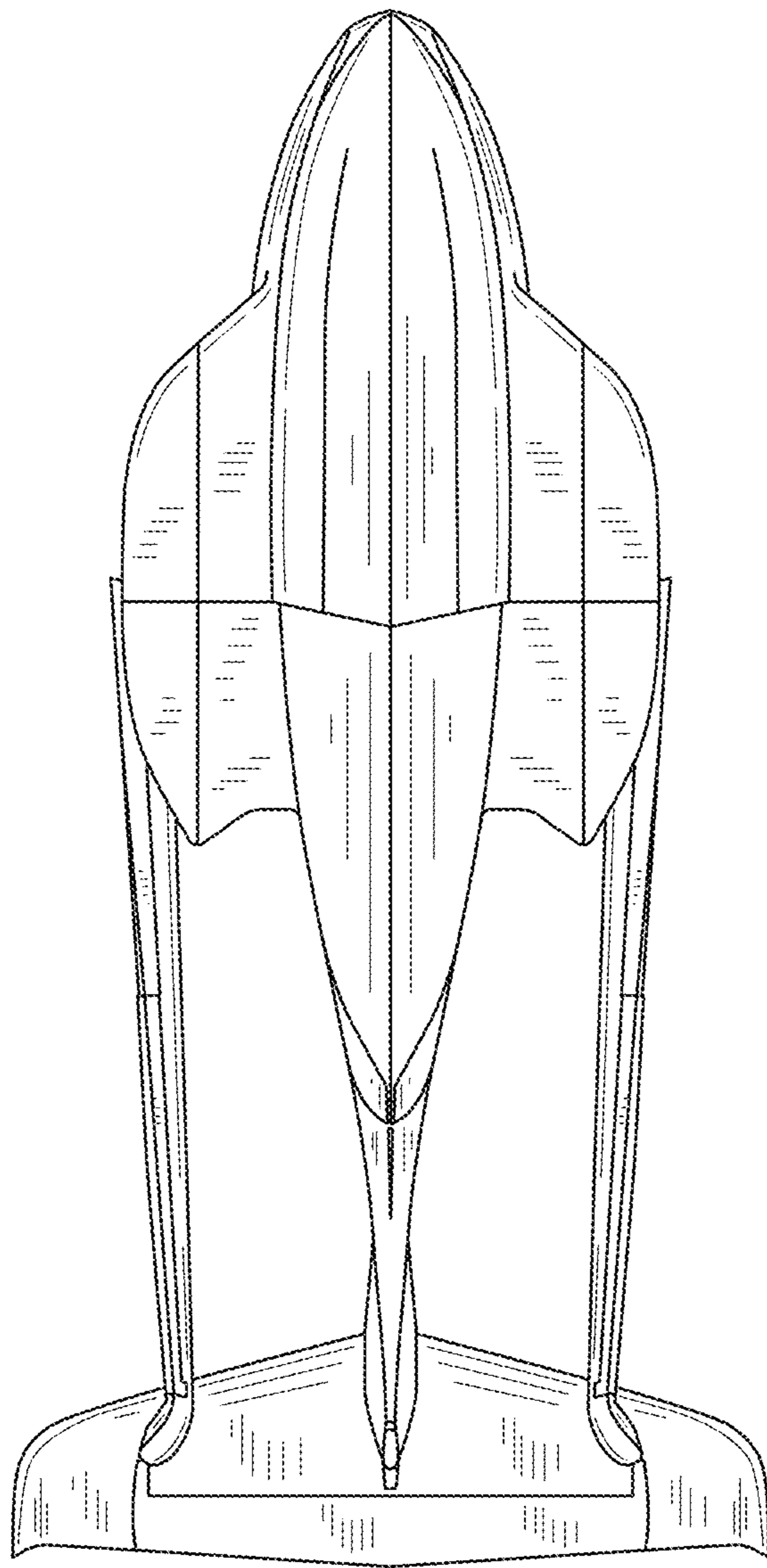

FIG.7