



US00D713497S

(12) **United States Design Patent**
Dobias et al.

(10) **Patent No.:** **US D713,497 S**

(45) **Date of Patent:** **** Sep. 16, 2014**

(54) **HOSE-END SPRAYER**

(71) Applicant: **Central Garden & Pet Company**,
Walnut Creek, CA (US)

(72) Inventors: **Scott F. Dobias**, Johns Creek, GA (US);
Christopher Carrick, Newark, DE
(US); **Jesse Gala**, Summit, NJ (US);
Christopher Murray, Philadelphia, PA
(US); **Christopher Phelan**,
Collingswood, NJ (US); **David Schiff**,
Highland Park, NJ (US); **John Coleman**,
Manayunk, PA (US); **Mathieu**
Zastawny, Philadelphia, PA (US)

(73) Assignee: **Central Garden & Pet Company**,
Walnut Creek, CA (US)

(**) Term: **14 Years**

(21) Appl. No.: **29/448,844**

(22) Filed: **Mar. 14, 2013**

(51) **LOC (10) Cl.** **23-01**

(52) **U.S. Cl.**
USPC **D23/223**

(58) **Field of Classification Search**
USPC D23/213, 223, 225, 226; 239/302, 308,
239/310, 373, 337, 332-333, 459, 10
See application file for complete search history.

(56) **References Cited**

U.S. PATENT DOCUMENTS

555,318 A 2/1896 Hitt
2,031,672 A 2/1936 Schaefer

(Continued)

FOREIGN PATENT DOCUMENTS

EP 2 439 357 4/2012
WO WO-2010/059494 A2 5/2010

OTHER PUBLICATIONS

U.S. Appl. No. 13/832,204, filed Mar. 15, 2013, Dobias et al.

Primary Examiner — Robin V Webster

(74) *Attorney, Agent, or Firm* — Womble, Carlyle,
Sandridge & Rice, LLP

(57) **CLAIM**

The ornamental design for a hose-end sprayer, as shown and
described.

DESCRIPTION

FIG. 1 is a front pictorial view of a hose-end sprayer in a
closed configuration;
FIG. 2 is a rear pictorial view of the hose-end sprayer of FIG.
1 in the closed configuration;
FIG. 3 is a right elevation view of the hose-end sprayer of FIG.
1 in the closed configuration;
FIG. 4 is a left elevation view of the hose-end sprayer of FIG.
1 in the closed configuration;
FIG. 5 is a top plan view of the hose-end sprayer of FIG. 1 in
the closed configuration;
FIG. 6 is a bottom plan view of the hose-end sprayer of FIG.
1 in the closed configuration;
FIG. 7 is front elevation view of the hose-end sprayer of FIG.
1 in the closed configuration;
FIG. 8 is a rear elevation view of the hose-end sprayer of FIG.
1 in the closed configuration;
FIG. 9 is a front pictorial view of the hose-end sprayer of FIG.
1 in an open configuration;
FIG. 10 is a rear pictorial view of the hose-end sprayer of FIG.
1 in the open configuration;
FIG. 11 is a right elevation view of the hose-end sprayer of
FIG. 1 in the open configuration;
FIG. 12 is a left elevation view of the hose-end sprayer of FIG.
1 in the open configuration;
FIG. 13 is a front elevation view of the hose-end sprayer of
FIG. 1 in the open configuration;
FIG. 14 is a rear elevation view of the hose-end sprayer of
FIG. 1 in the open configuration;
FIG. 15 is a top plan view of the hose-end sprayer of FIG. 1 in
the open configuration; and,
FIG. 16 is a bottom plan view of the hose-end sprayer of FIG.
1 in the open configuration.
The broken line showing is included for the purpose of illus-
trating and forms no part of the claimed design.

1 Claim, 15 Drawing Sheets

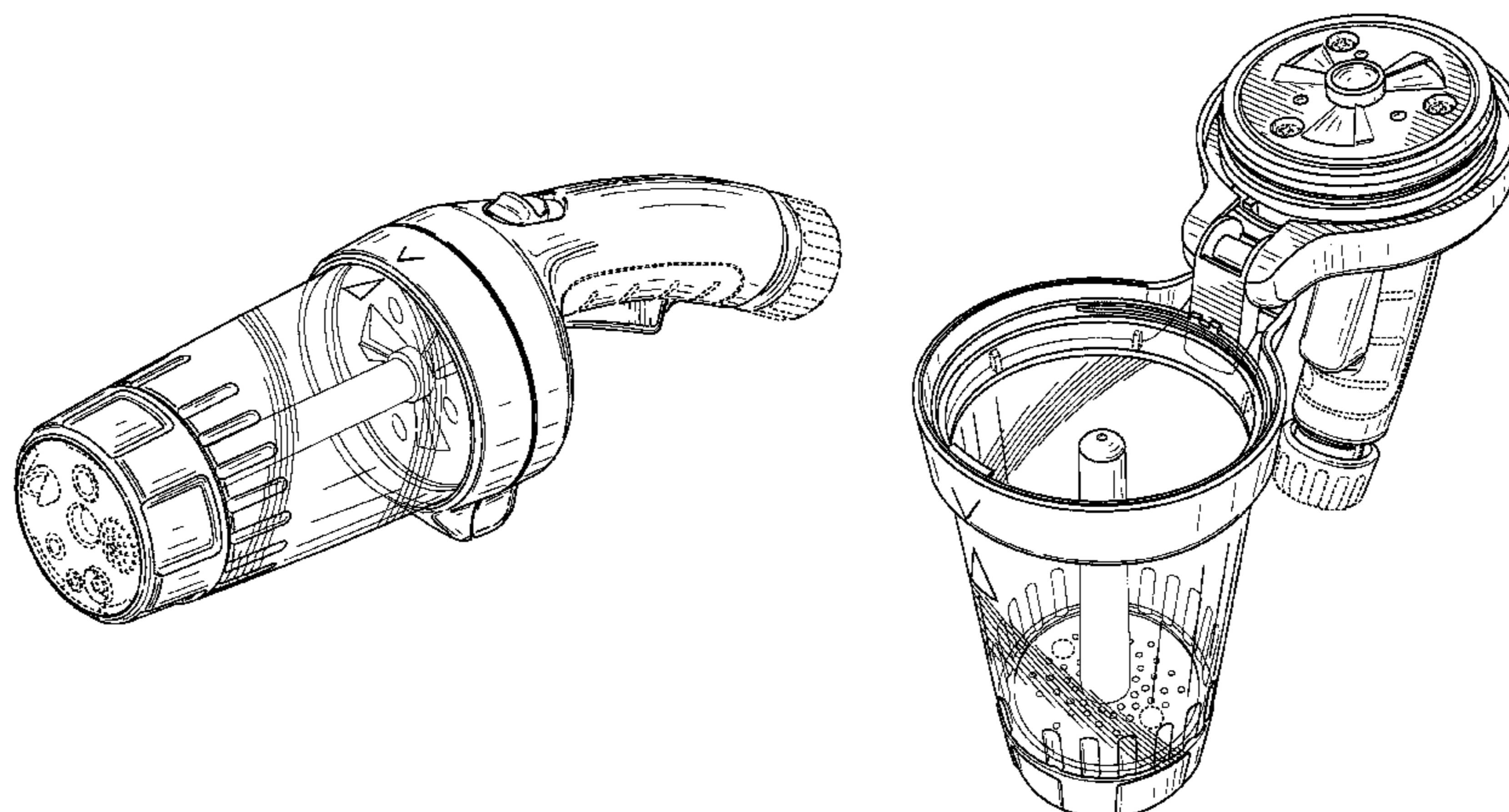

(56)

References Cited

U.S. PATENT DOCUMENTS

2,372,154 A	3/1945	Ahern	6,009,663 A	1/2000	Kazemzadeh
2,536,277 A	1/1951	Grieme	6,050,459 A	4/2000	Johnson et al.
2,564,058 A	8/1951	Fletcher et al.	6,161,779 A	12/2000	Oyler et al.
3,116,856 A	1/1964	Prussin et al.	D442,671 S *	5/2001	Chih D23/223
3,148,806 A	9/1964	Meshberg	6,321,941 B1	11/2001	Argentieri et al.
3,402,862 A	9/1968	Meshberg	6,367,665 B1	4/2002	Barriac et al.
3,554,450 A	1/1971	D'Muhala	6,409,052 B1	6/2002	Barriac et al.
3,845,902 A	11/1974	Delamater	6,419,128 B1	7/2002	Barriac et al.
3,893,630 A	7/1975	Bochmann	6,508,410 B1	1/2003	Thomas, Jr. et al.
3,901,449 A	8/1975	Bochmann	6,511,001 B1	1/2003	Huang
3,904,116 A	9/1975	Jones et al.	6,554,319 B2	4/2003	Barriac et al.
3,933,308 A	1/1976	Bradley et al.	6,644,564 B2	11/2003	Perkitny
4,039,105 A	8/1977	Chan	6,796,464 B1	9/2004	Tung
4,081,006 A	3/1978	Crowell et al.	6,811,100 B2	11/2004	Bardinet et al.
D254,321 S	2/1980	Sidor et al.	6,824,025 B1	11/2004	Ruble et al.
4,333,493 A	6/1982	Beiswenger et al.	D503,456 S *	3/2005	Chen D23/223
D272,380 S	1/1984	Poon	7,032,841 B1	4/2006	Swisher
4,475,689 A	10/1984	Hauger et al.	D524,906 S	7/2006	Birrenkott et al.
4,512,955 A	4/1985	Etani	7,097,119 B2	8/2006	Hornsby et al.
4,618,099 A	10/1986	Nagao et al.	D529,575 S	10/2006	Birrenkott et al.
4,621,770 A	11/1986	Sayen	D536,970 S	2/2007	Shannan et al.
4,775,104 A	10/1988	Harkins	7,182,280 B2	2/2007	Ye et al.
4,790,454 A	12/1988	Clark et al.	7,204,382 B2	4/2007	Cezeaux
4,801,088 A	1/1989	Baker	7,207,500 B2	4/2007	Hudson et al.
4,925,105 A	5/1990	Lin	7,246,755 B2	7/2007	Hornsby et al.
4,955,544 A	9/1990	Kopp	7,296,761 B1	11/2007	Laible
D314,649 S *	2/1991	Campbell et al. D32/17	7,328,859 B2	2/2008	Hornsby et al.
5,029,738 A	7/1991	Dillon	D569,478 S	5/2008	Cichy et al.
5,150,841 A	9/1992	Silvenis et al.	7,384,006 B2	6/2008	Hornsby et al.
5,154,324 A	10/1992	Stratford	7,398,726 B2	7/2008	Streeter et al.
5,156,298 A	10/1992	LaRue	7,513,444 B1	4/2009	Kurimski et al.
5,181,533 A	1/1993	Kooi	7,562,834 B2	7/2009	Hornsby et al.
5,199,948 A	4/1993	McPhee	7,568,637 B2	8/2009	Hornsby et al.
5,273,186 A	12/1993	Widmer	7,588,198 B2	9/2009	Hornsby et al.
5,332,158 A	7/1994	Styne et al.	7,690,392 B1	4/2010	Sarkiss
D350,287 S	9/1994	Kobayashi et al.	7,717,354 B1	5/2010	Robinson
D352,344 S	11/1994	Mizuguchi	7,819,292 B2	10/2010	Arcuri et al.
5,419,494 A	5/1995	Harwood	8,056,774 B2	11/2011	Arcuri et al.
5,425,528 A	6/1995	Rains et al.	D670,788 S	11/2012	Plantz et al.
5,469,993 A	11/1995	Hauf et al.	D670,982 S	11/2012	Goodwin et al.
5,526,963 A	6/1996	Smith	D678,464 S	3/2013	Chen
5,553,750 A	9/1996	Foster	2005/0082389 A1	4/2005	Sanchez et al.
5,582,350 A	12/1996	Kosmyna et al.	2007/0131794 A1	6/2007	Lai et al.
5,716,007 A	2/1998	Nottingham et al.	2008/0296398 A1	12/2008	Hickman et al.
5,752,661 A	5/1998	Lewis	2010/0193517 A1	8/2010	Takanohashi
5,906,316 A	5/1999	Gatzemeyer et al.	2010/0243760 A1	9/2010	Birrenkott et al.
			2010/0282866 A1	11/2010	Gilpatrick et al.

* cited by examiner

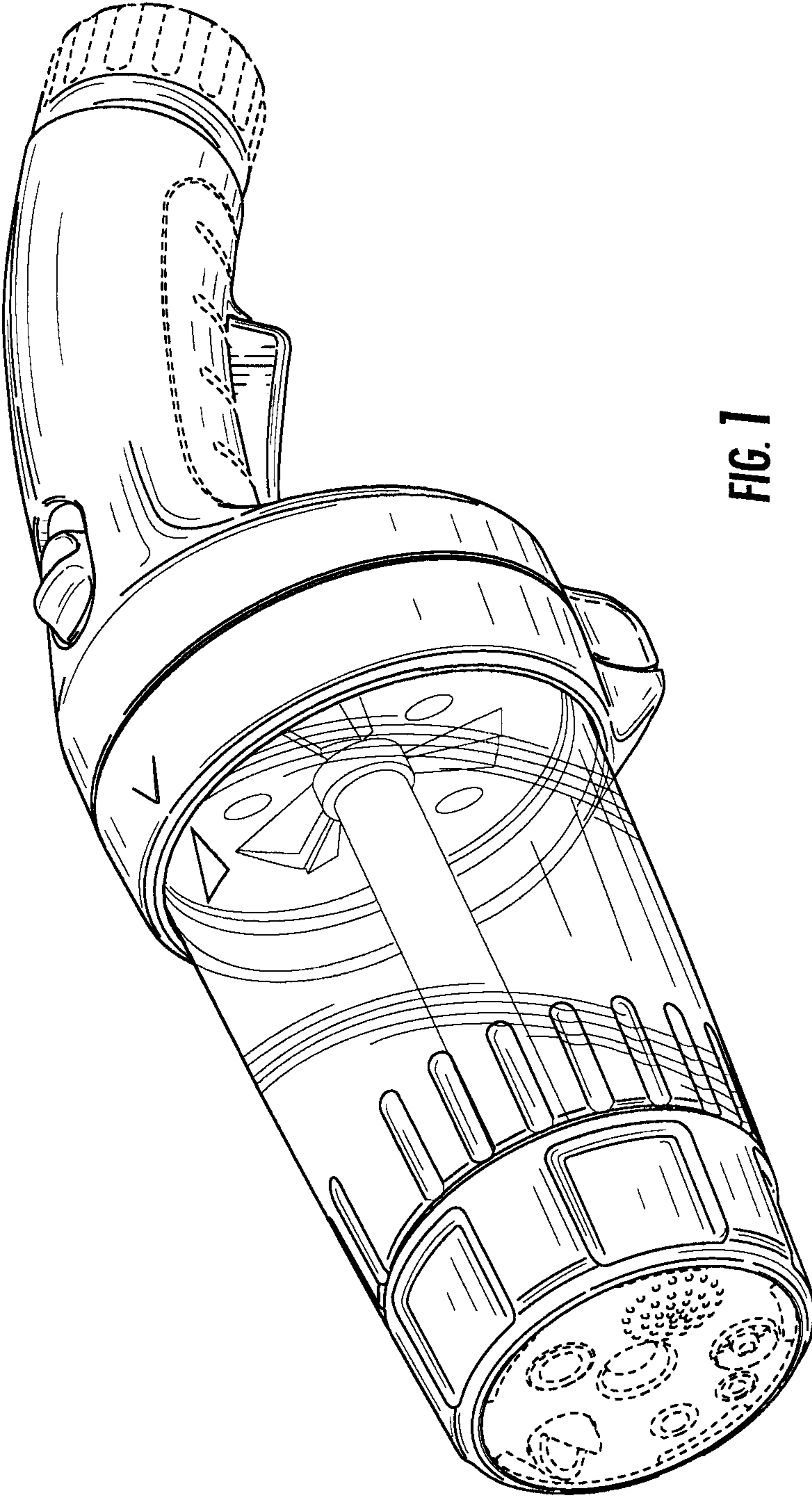

FIG. 1

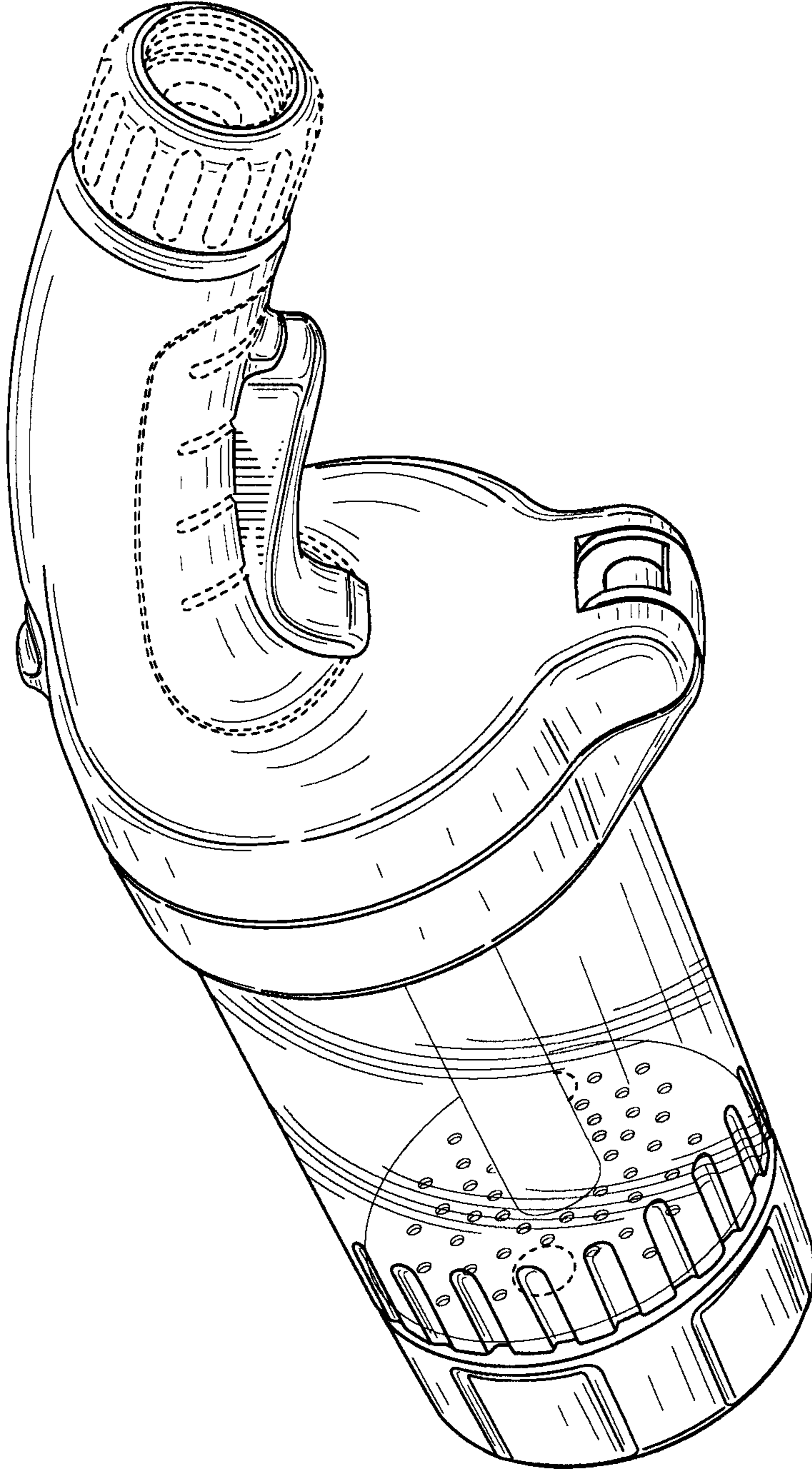

FIG. 2

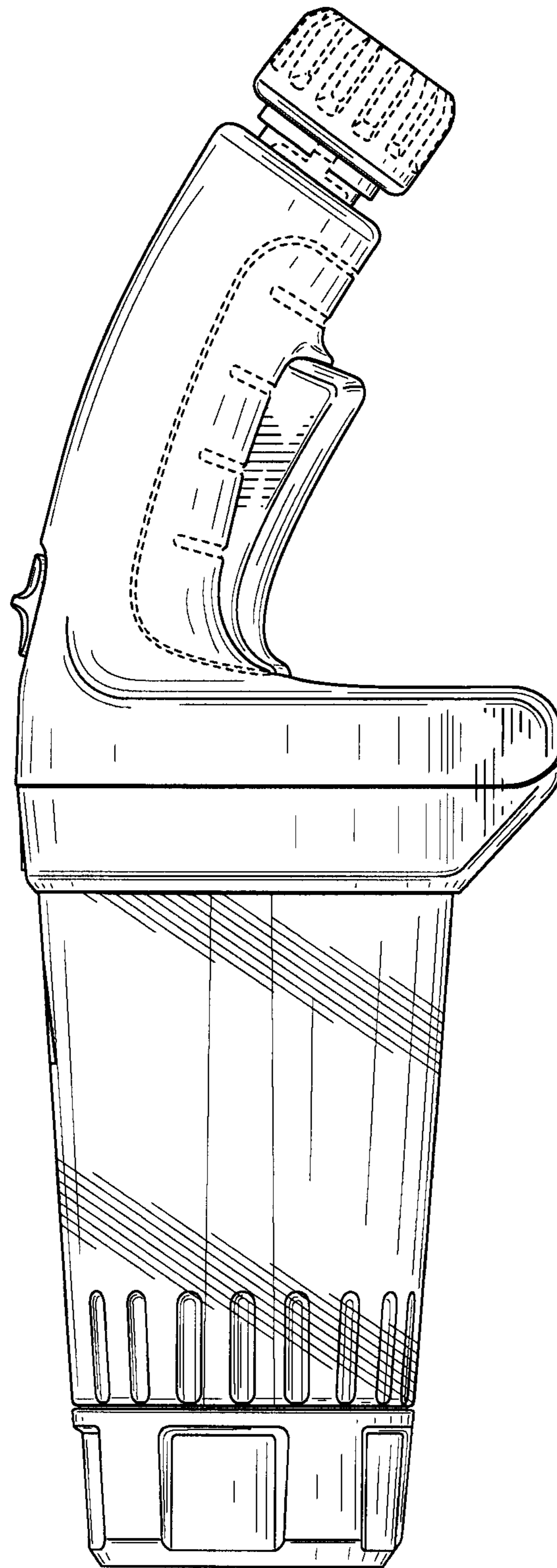

FIG. 3

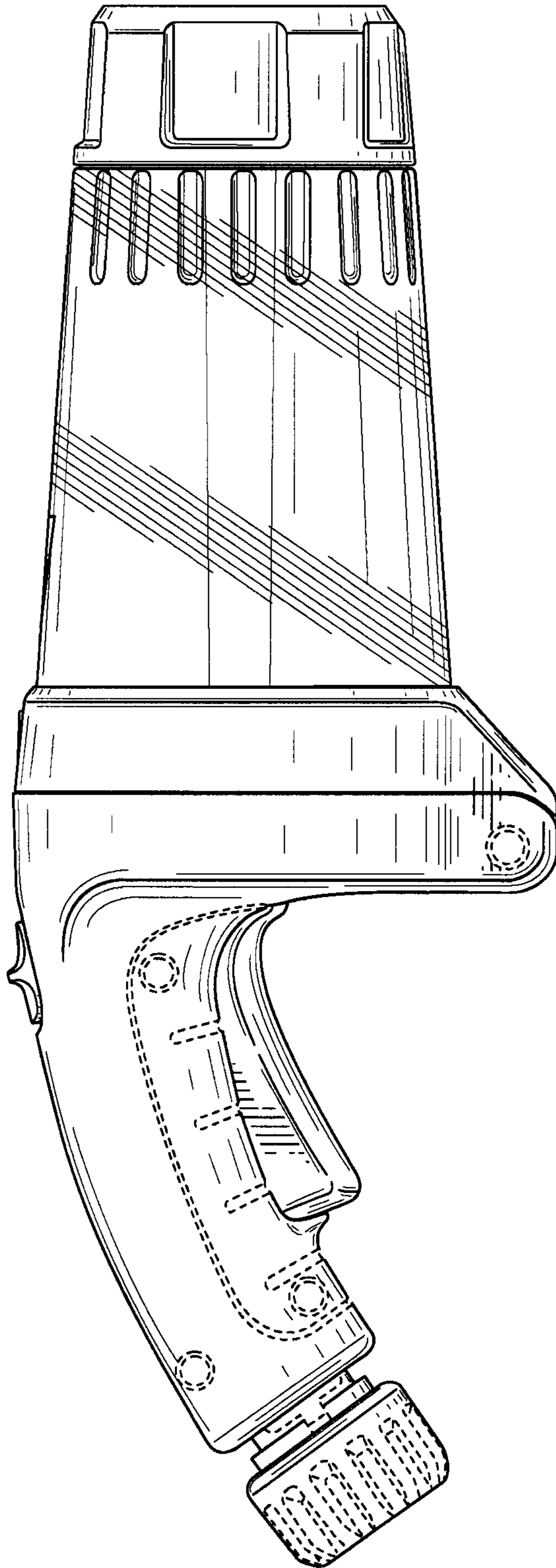

FIG. 4

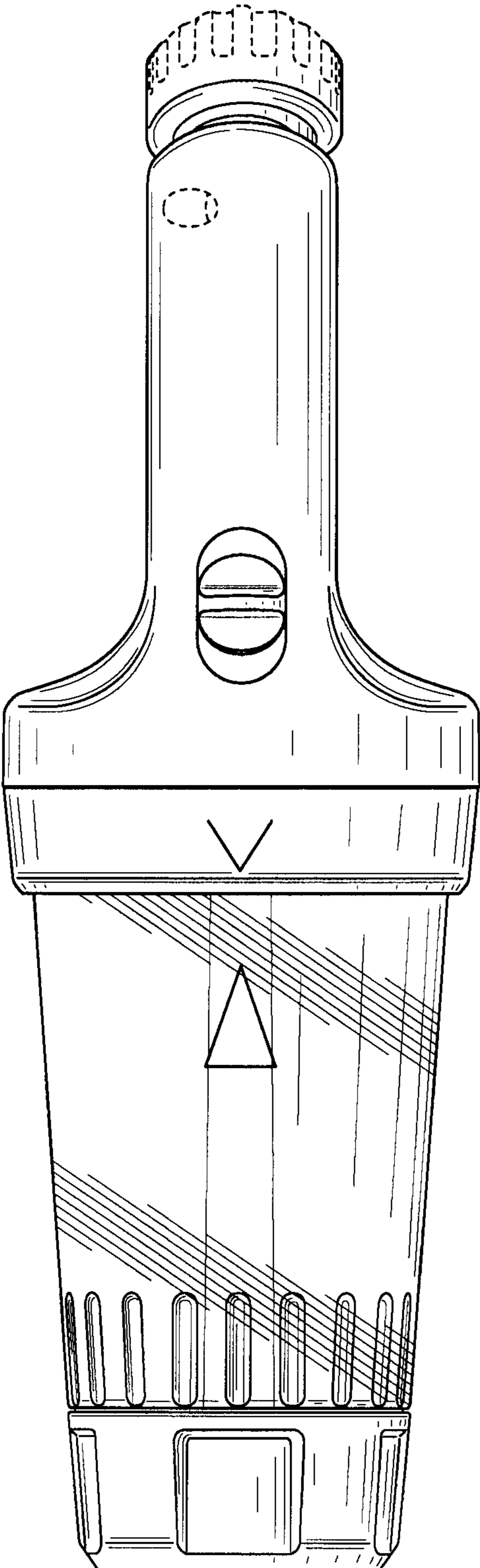

FIG. 5

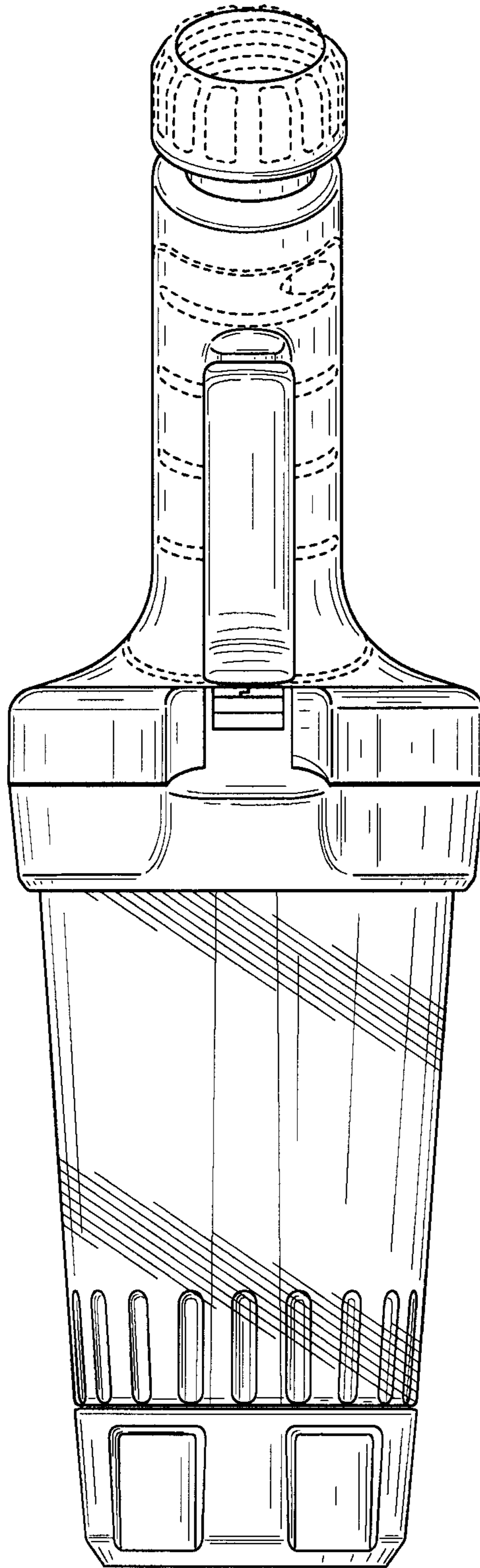

FIG. 6

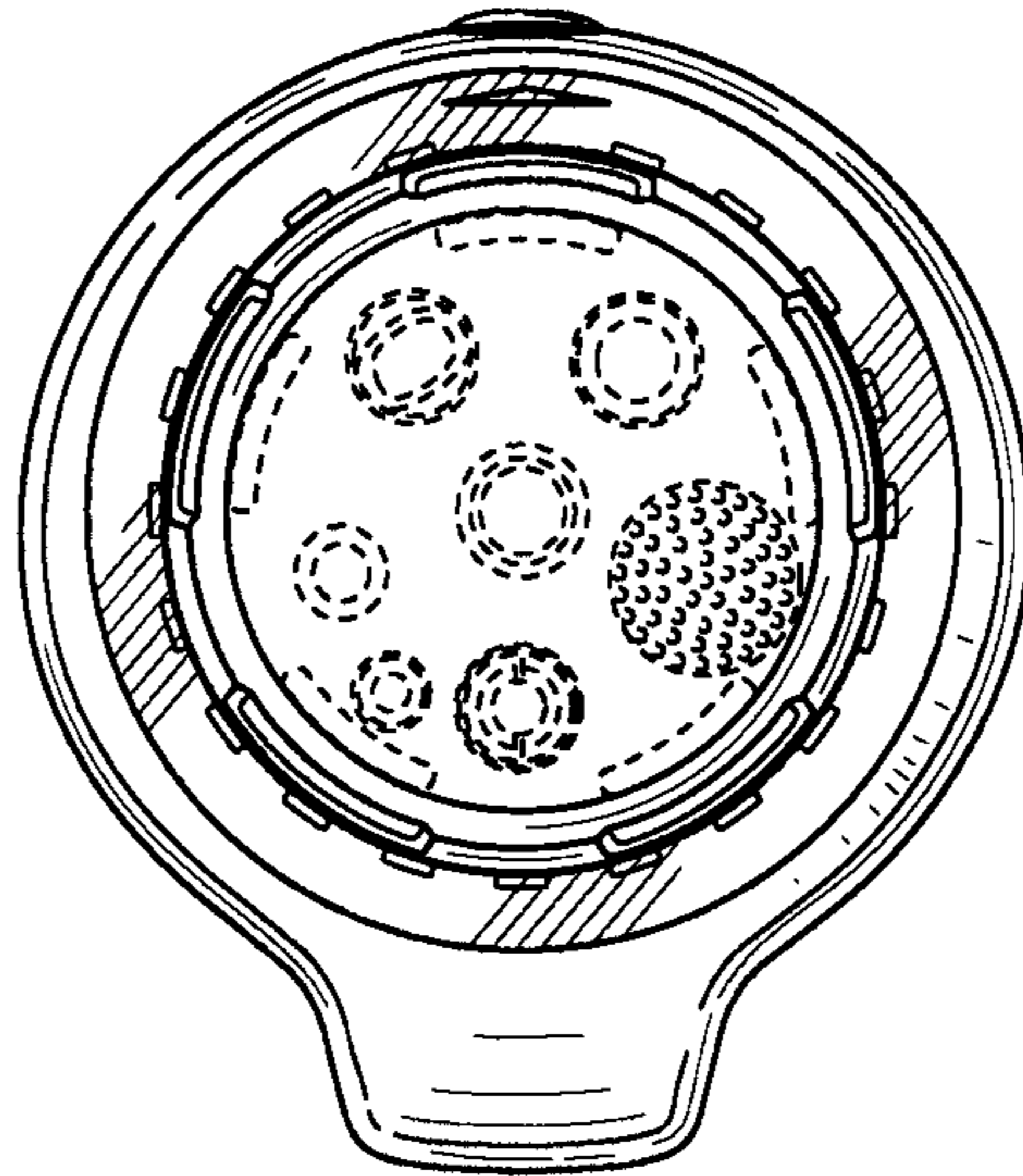

FIG. 7

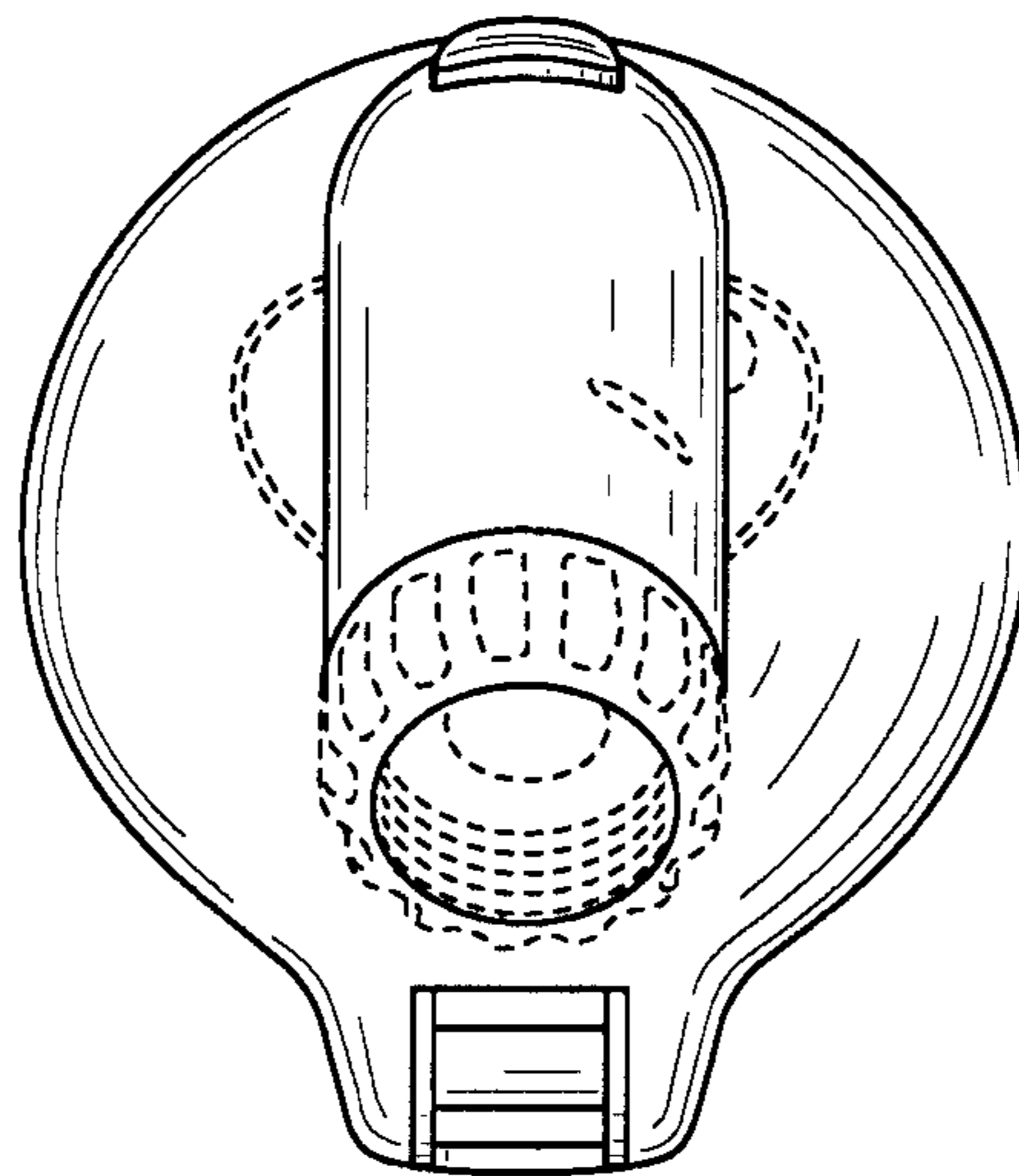

FIG. 8

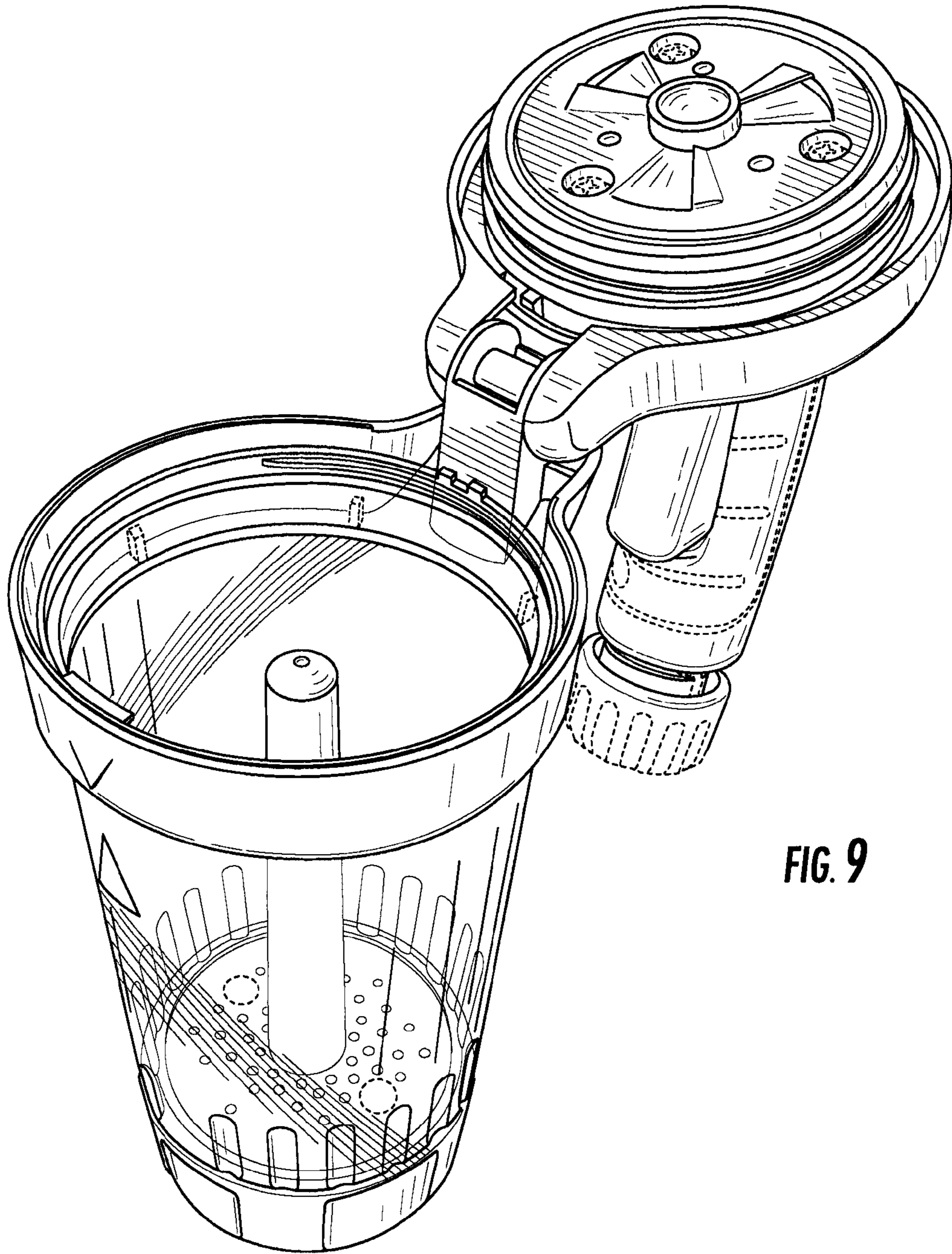

FIG. 9

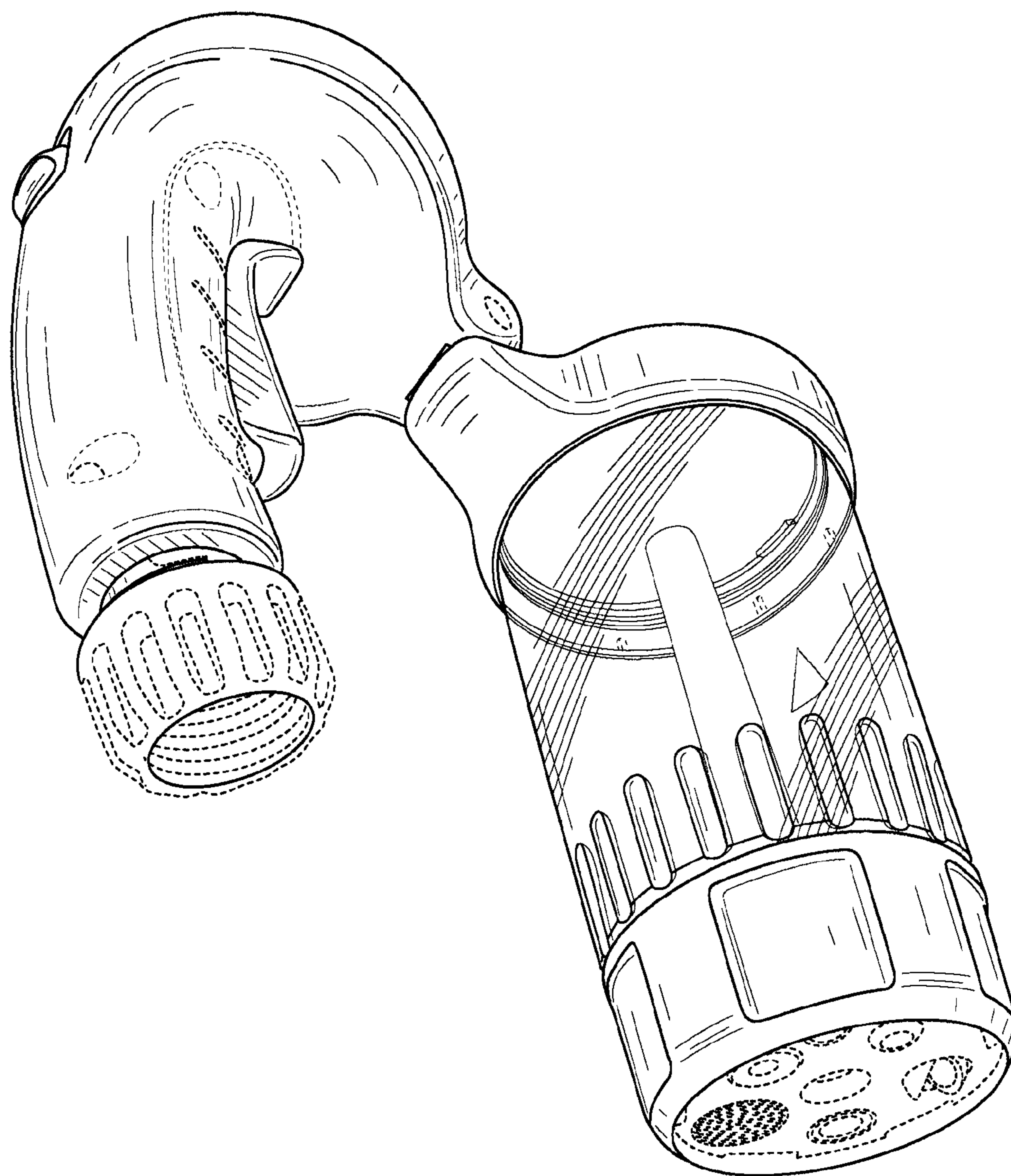

FIG. 10

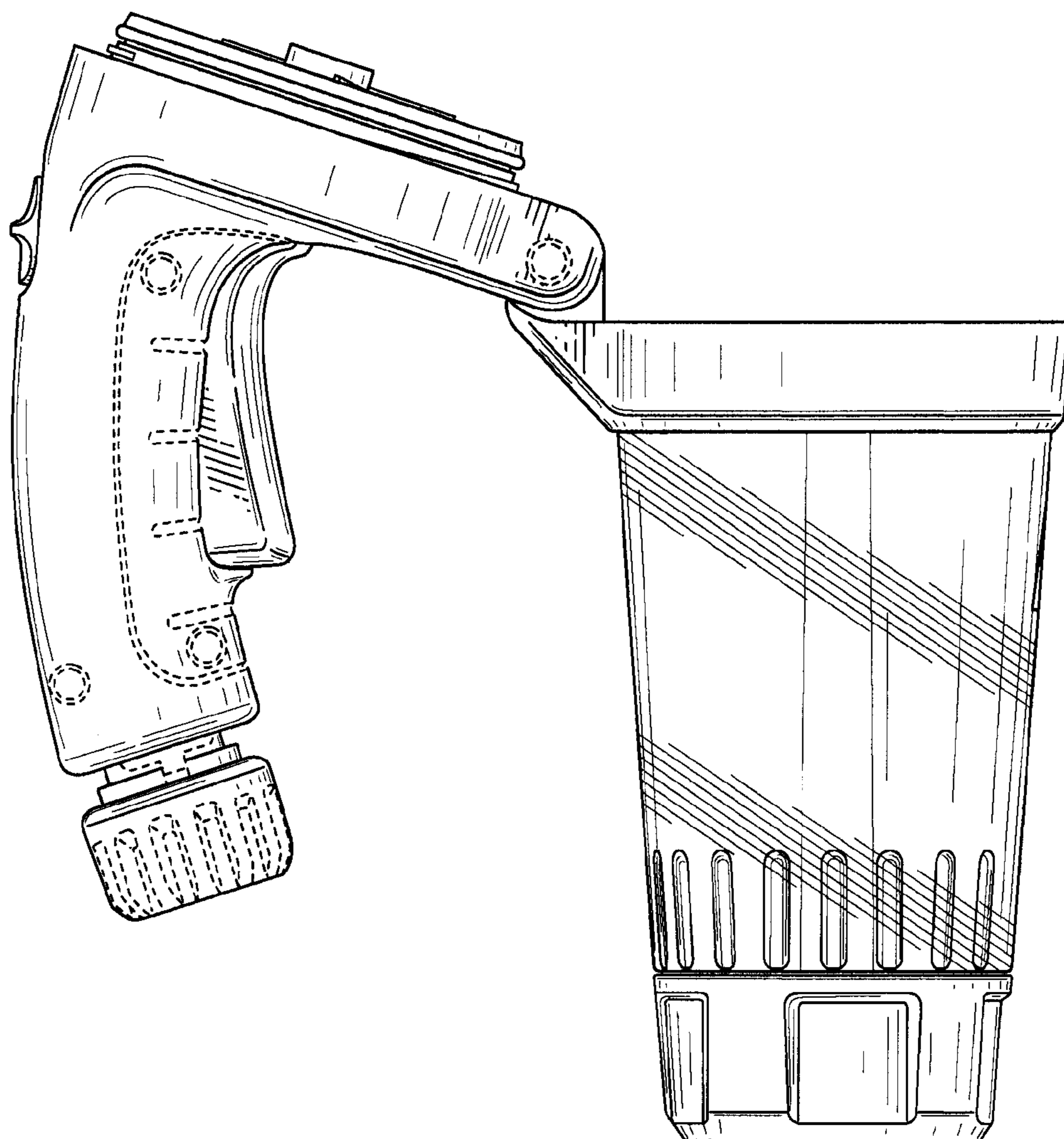

FIG. 11

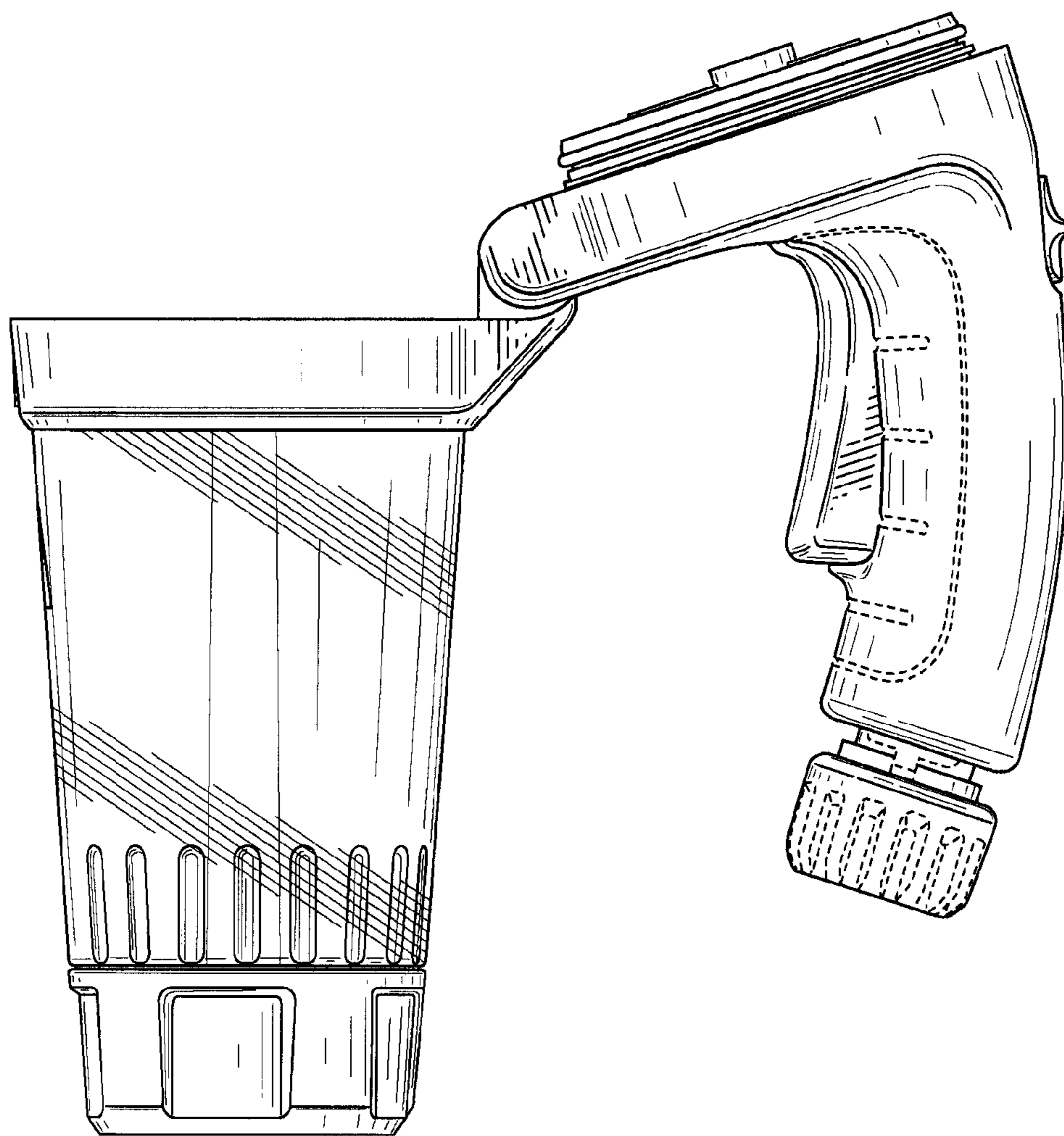

FIG. 12

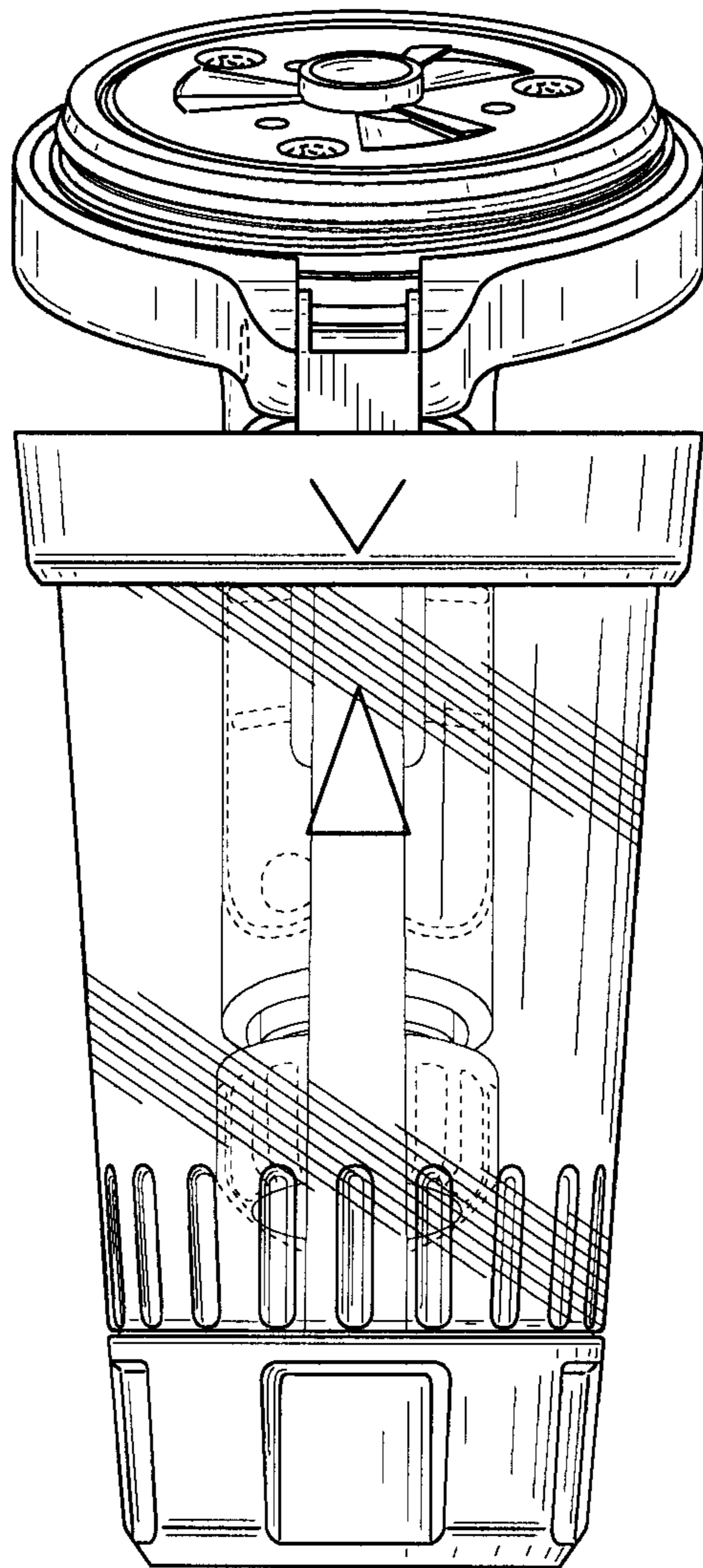

FIG. 13

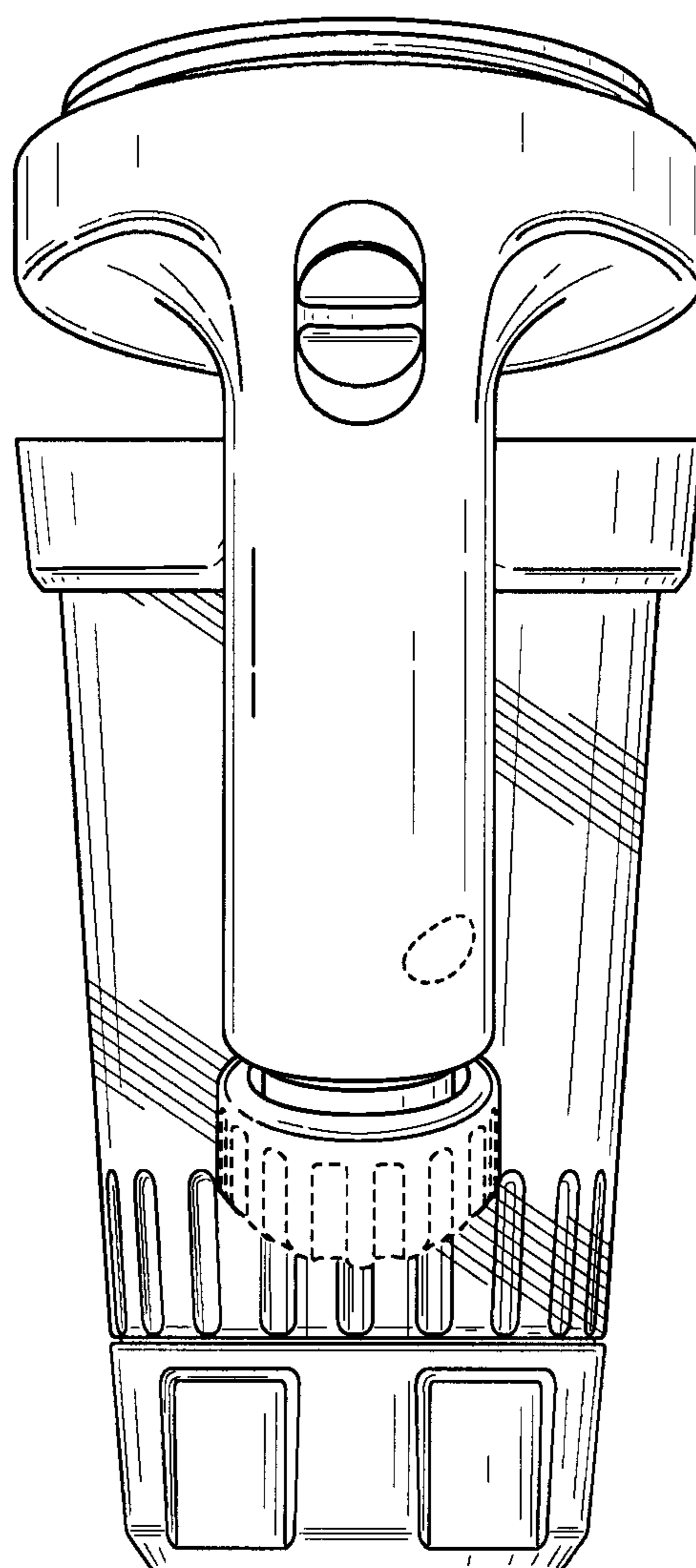

FIG. 14

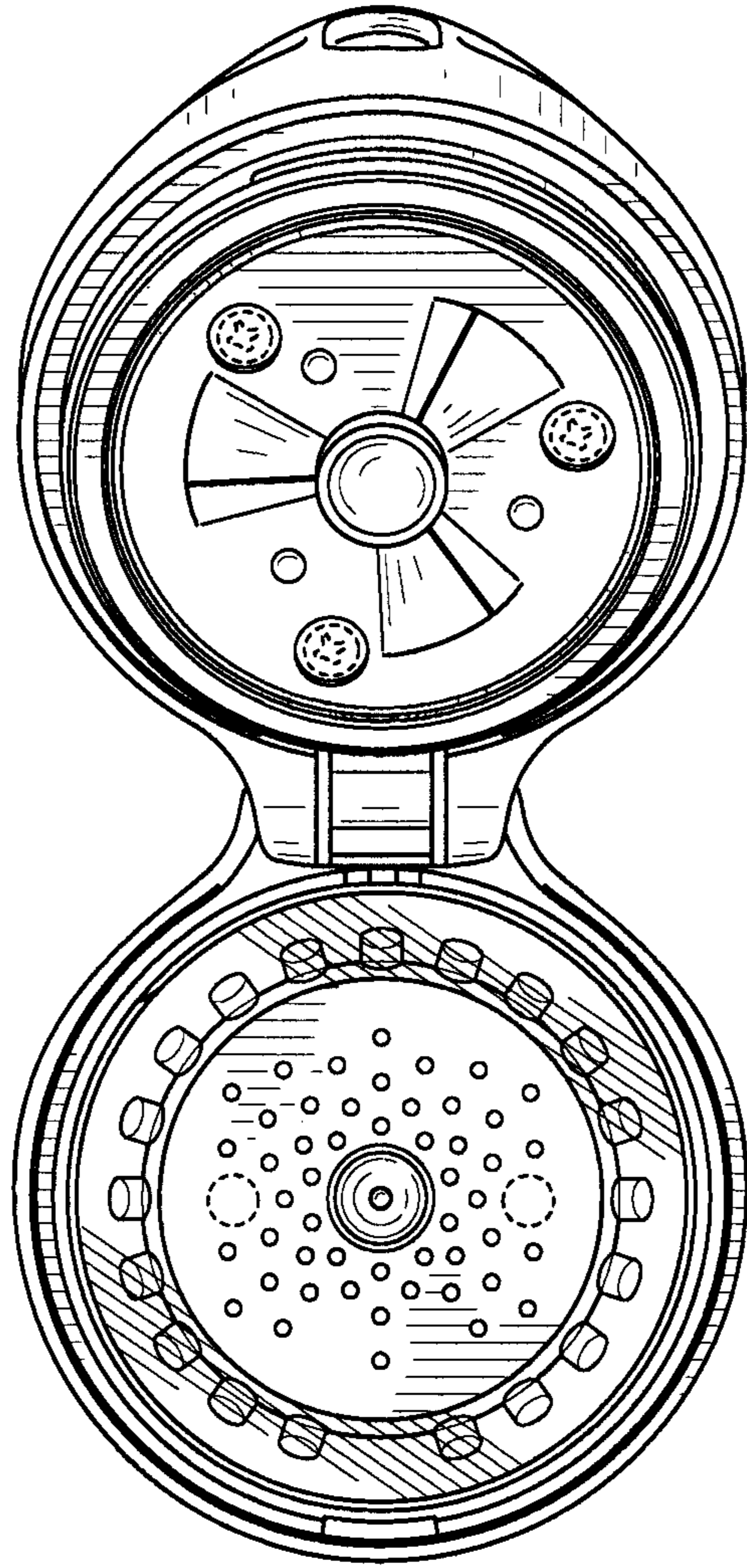

FIG. 15

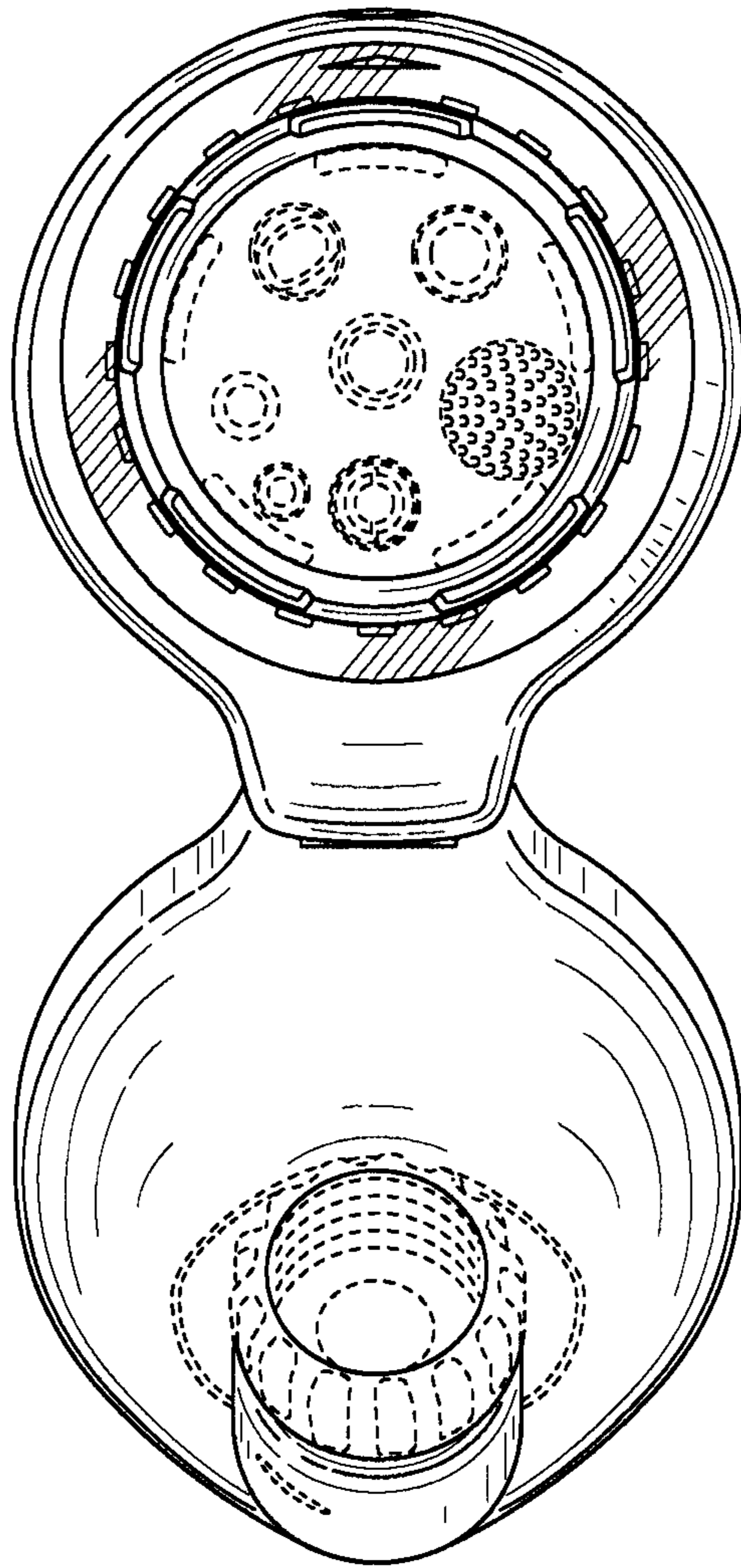

FIG. 16