



US00D713347S

(12) **United States Design Patent**
Ueda

(10) **Patent No.:** **US D713,347 S**

(45) **Date of Patent:** **** Sep. 16, 2014**

(54) **ELECTRICAL CONNECTOR**

(71) Applicant: **Japan Aviation Electronics Industry, Limited, Tokyo (JP)**

(72) Inventor: **Kouhei Ueda, Tokyo (JP)**

(73) Assignee: **Japan Aviation Electronics Industry, Limited, Tokyo (JP)**

(**) Term: **14 Years**

(21) Appl. No.: **29/467,198**

(22) Filed: **Sep. 17, 2013**

(30) **Foreign Application Priority Data**

Apr. 8, 2013 (JP) 2013-007864

(51) **LOC (10) Cl.** **13-03**

(52) **U.S. Cl.**
USPC **D13/147**

(58) **Field of Classification Search**
USPC D13/147, 154, 184, 199; 439/79, 108,
439/180, 246, 374, 378, 488, 527, 529, 530,
439/533, 567, 607.1, 607.4, 607.5, 607.17,
439/607.25, 607.34, 607.41, 607.53, 668,
439/680, 892, 894

See application file for complete search history.

(56) **References Cited**

U.S. PATENT DOCUMENTS

D427,975 S * 7/2000 Zhu et al. D13/147
D446,772 S * 8/2001 Chen et al. D13/147
D446,773 S * 8/2001 Yao et al. D13/147

D500,988 S * 1/2005 Moriwake et al. D13/147
D520,954 S * 5/2006 Moriwake et al. D13/147
D522,971 S * 6/2006 Shang-Yen et al. D13/147
D537,786 S * 3/2007 Li D13/147
D592,145 S * 5/2009 Sun D13/147

OTHER PUBLICATIONS

Japanese Office Action dated Jul. 26, 2013, issued in corresponding Japanese application No. 2013-007864 (2 pages).

* cited by examiner

Primary Examiner — Daniel Bui

(74) *Attorney, Agent, or Firm* — Westerman, Hattori, Daniels & Adrian, LLP

(57) **CLAIM**

The ornamental design for an electrical connector, as shown and described.

DESCRIPTION

FIG. 1 is a front elevational view of an electrical connector, showing my new design;
FIG. 2 is a rear elevational view thereof;
FIG. 3 is a right side elevational view thereof;
FIG. 4 is a left side elevational view thereof;
FIG. 5 is a top plan view thereof;
FIG. 6 is a bottom plan view thereof;
FIG. 7 is a right front perspective view showing the top thereof;
FIG. 8 is a left rear perspective view showing the bottom thereof;
FIG. 9 is a right front perspective view showing the bottom thereof; and,
FIG. 10 is a left rear perspective view showing the top thereof. The broken line in the drawing is included to show unclaimed subject matter only and forms no part of the claimed design.

1 Claim, 10 Drawing Sheets

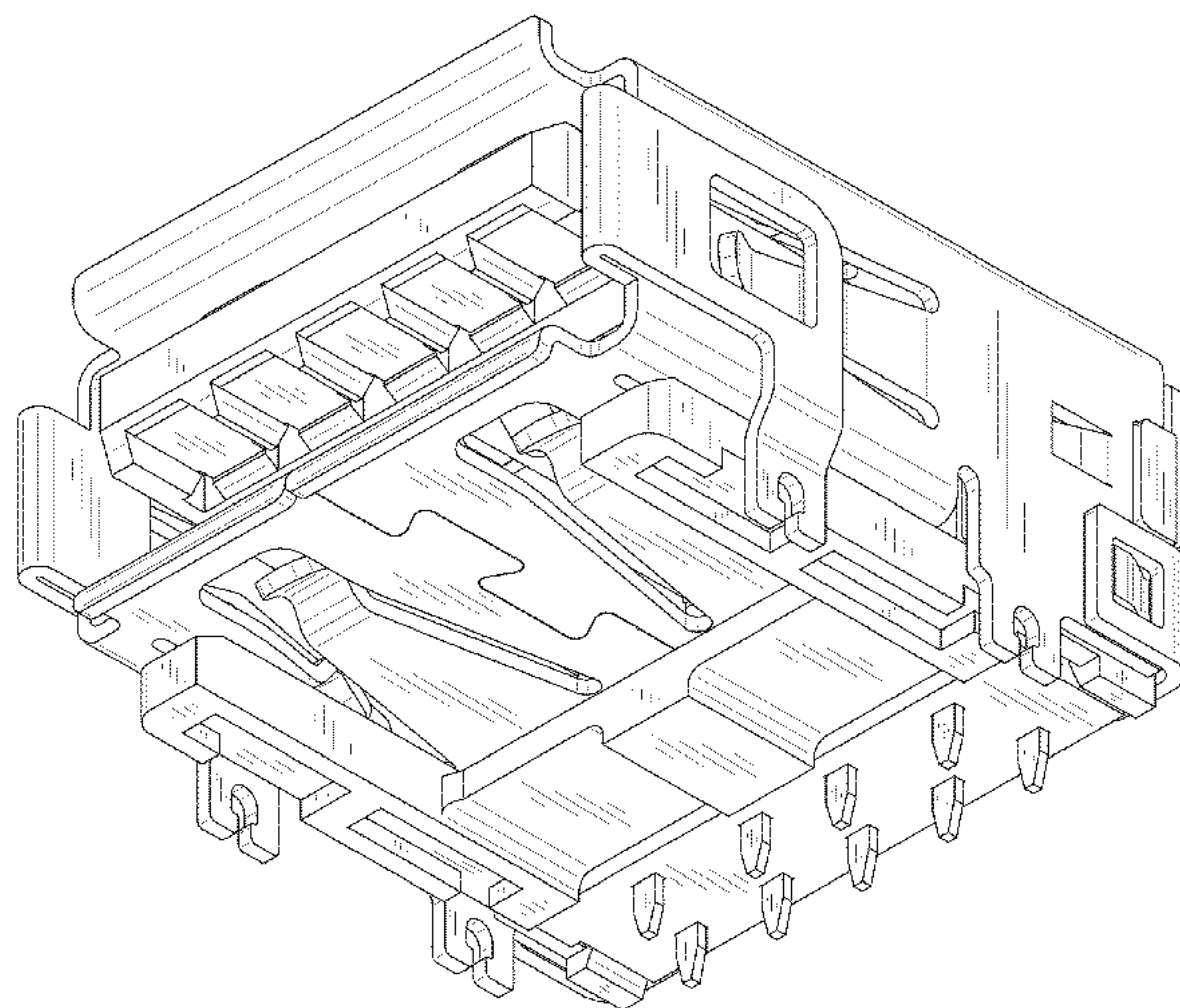
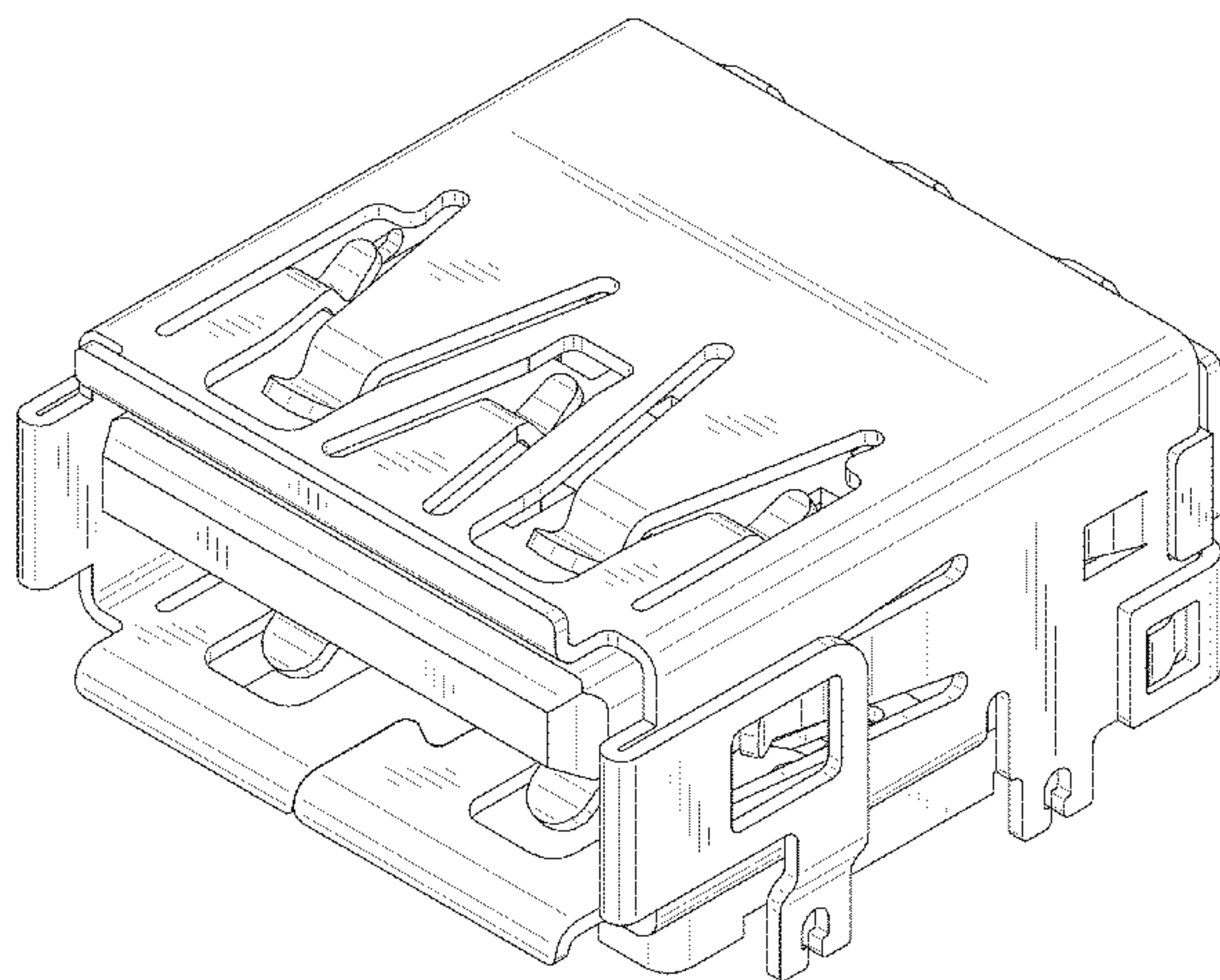

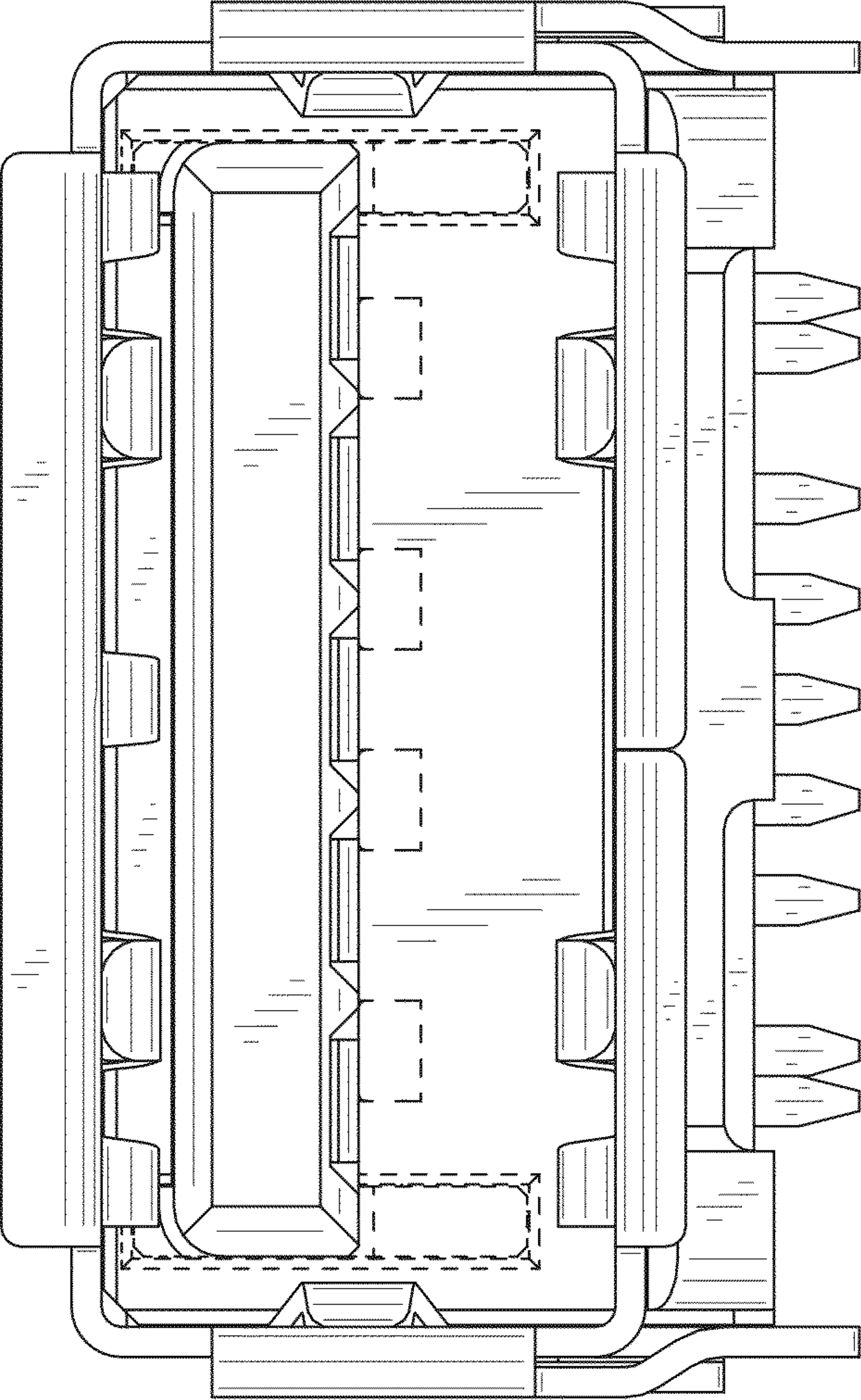

FIG.1

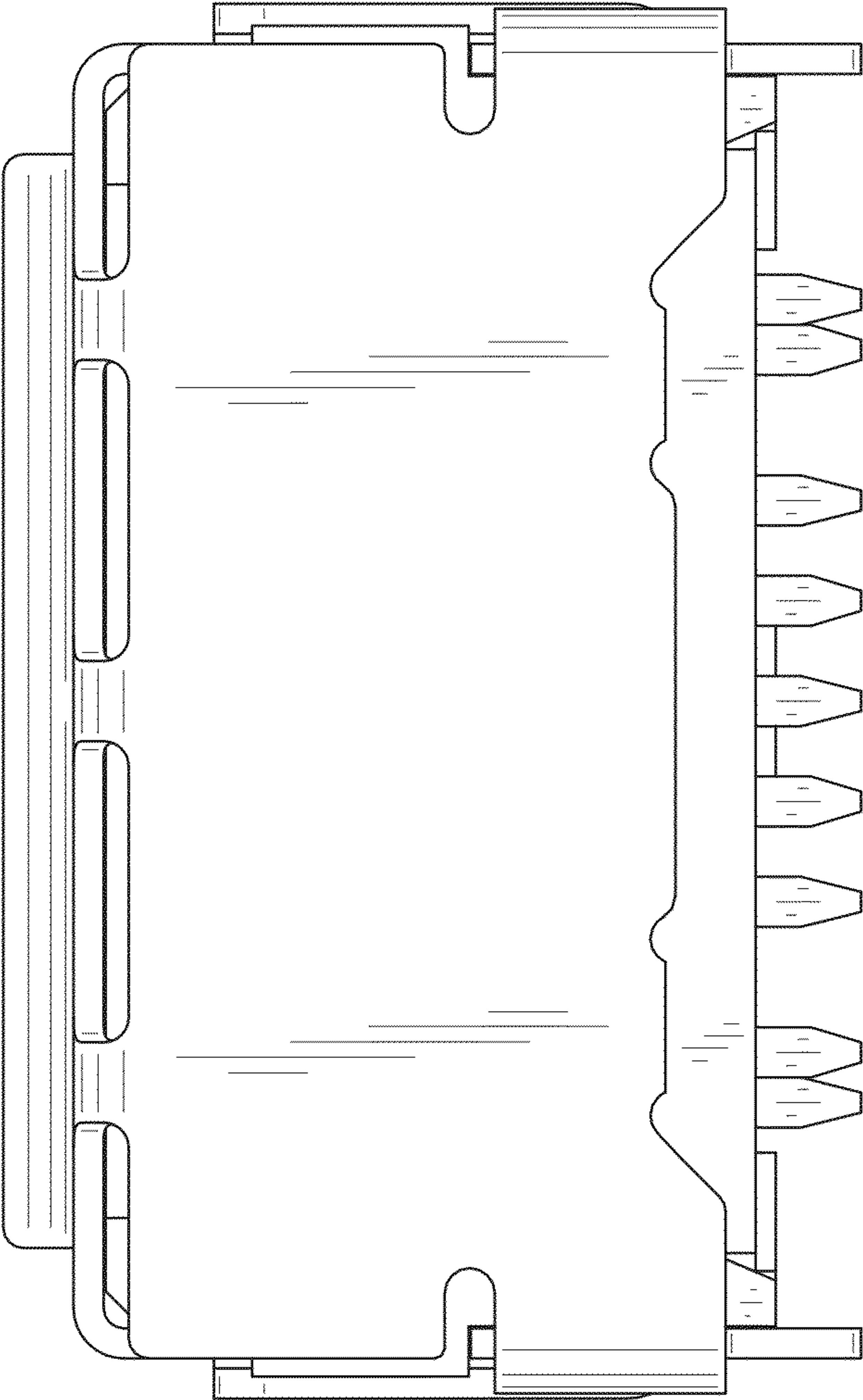

FIG.2

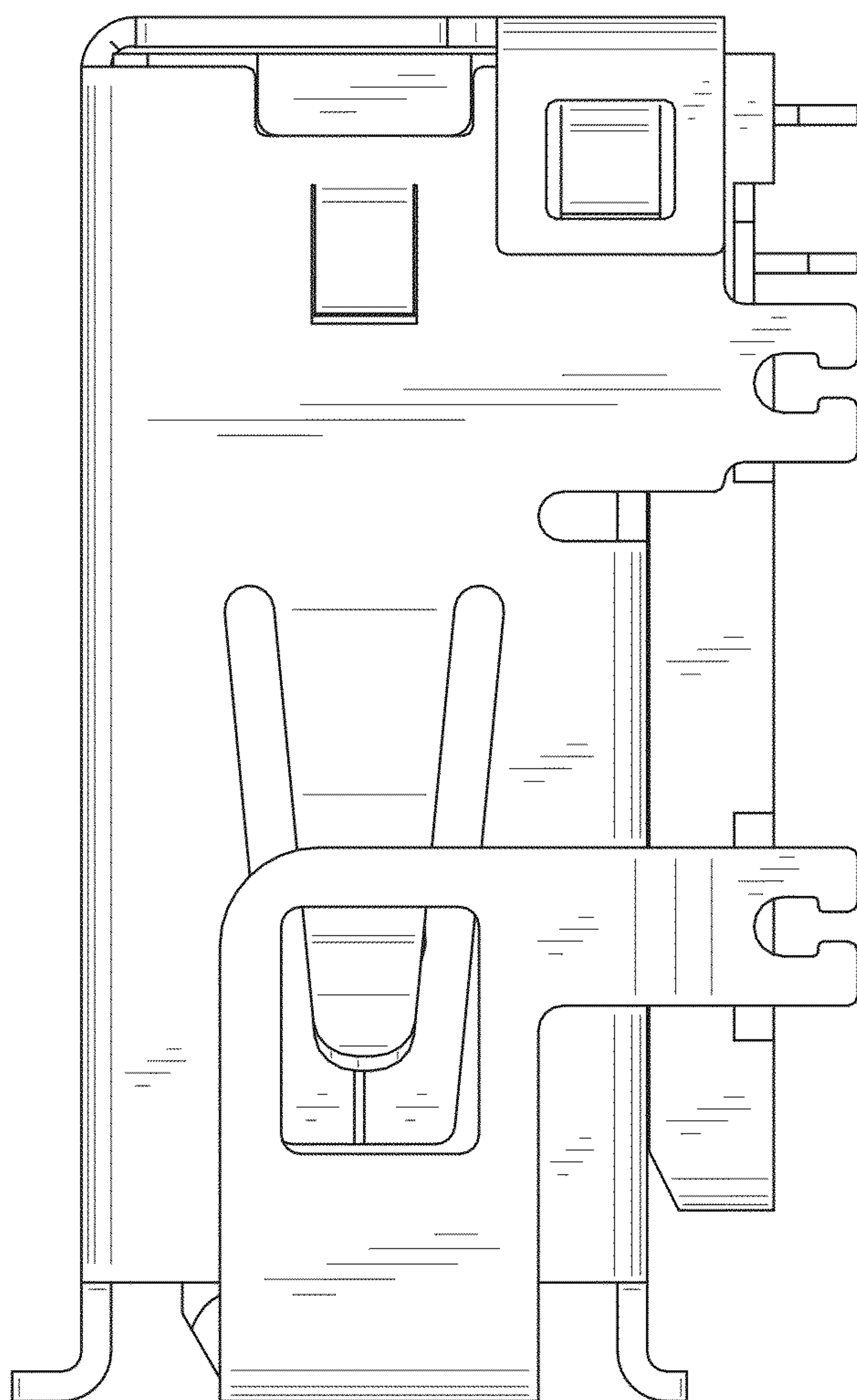

FIG.3

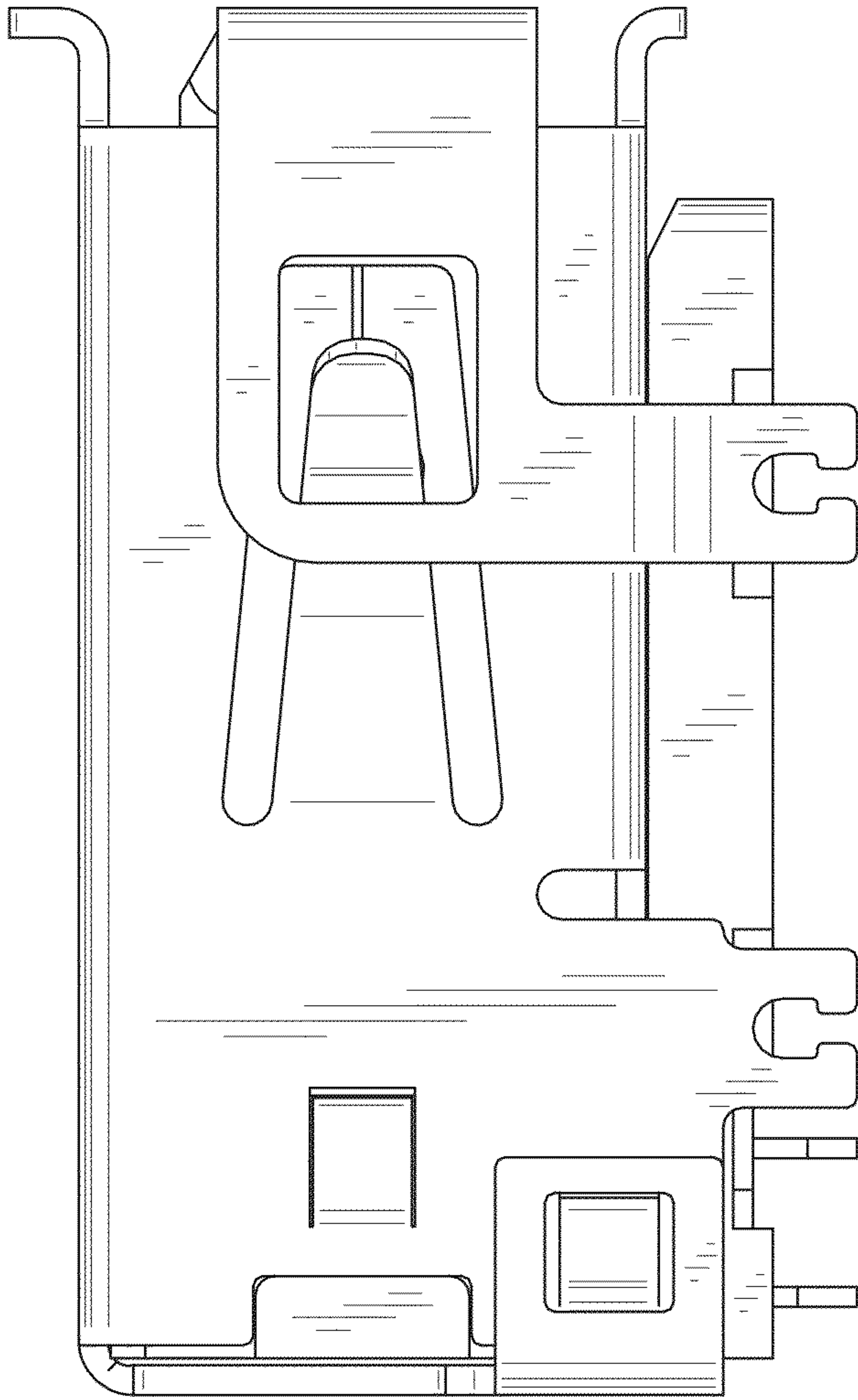

FIG.4

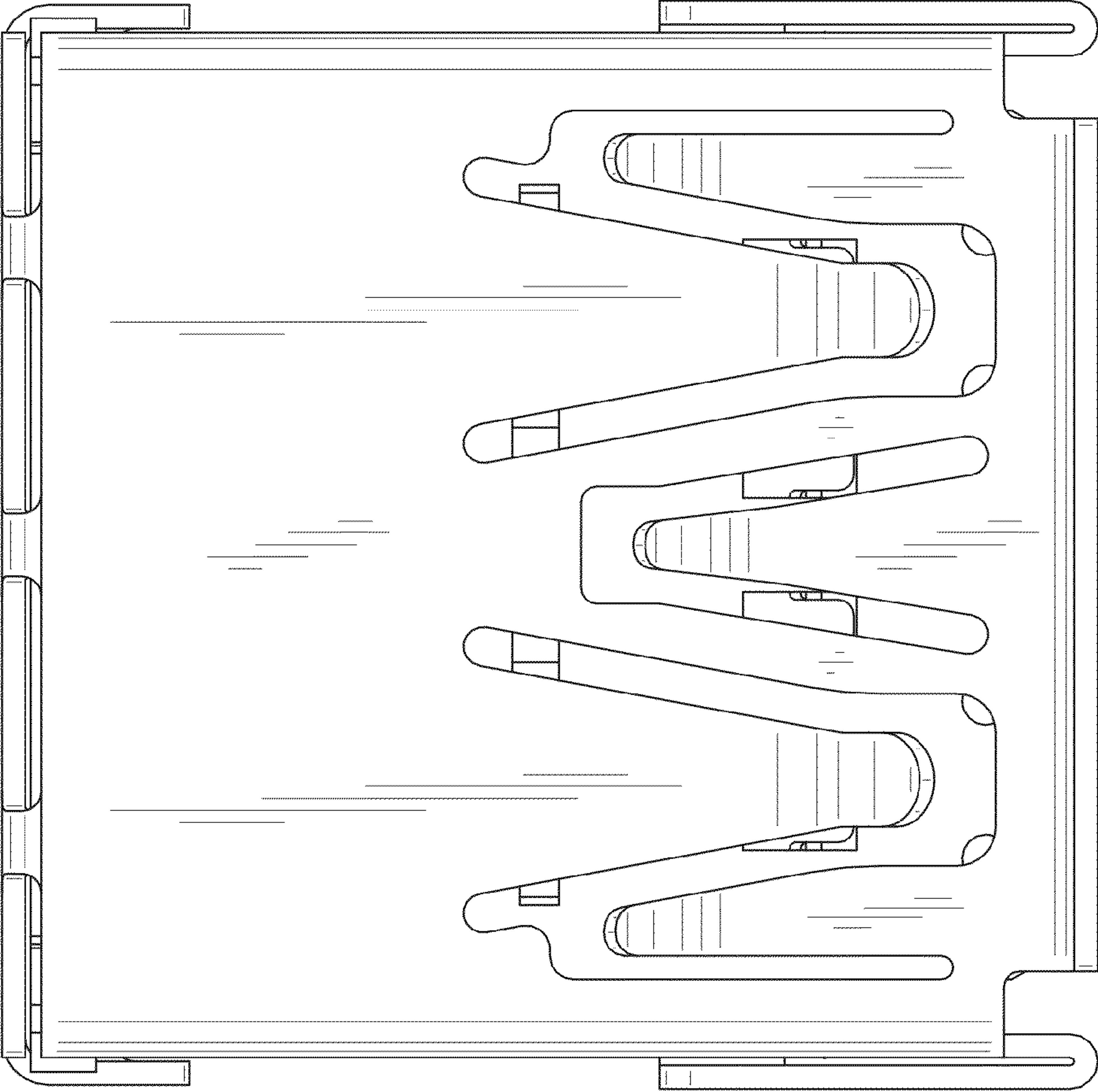

FIG.5

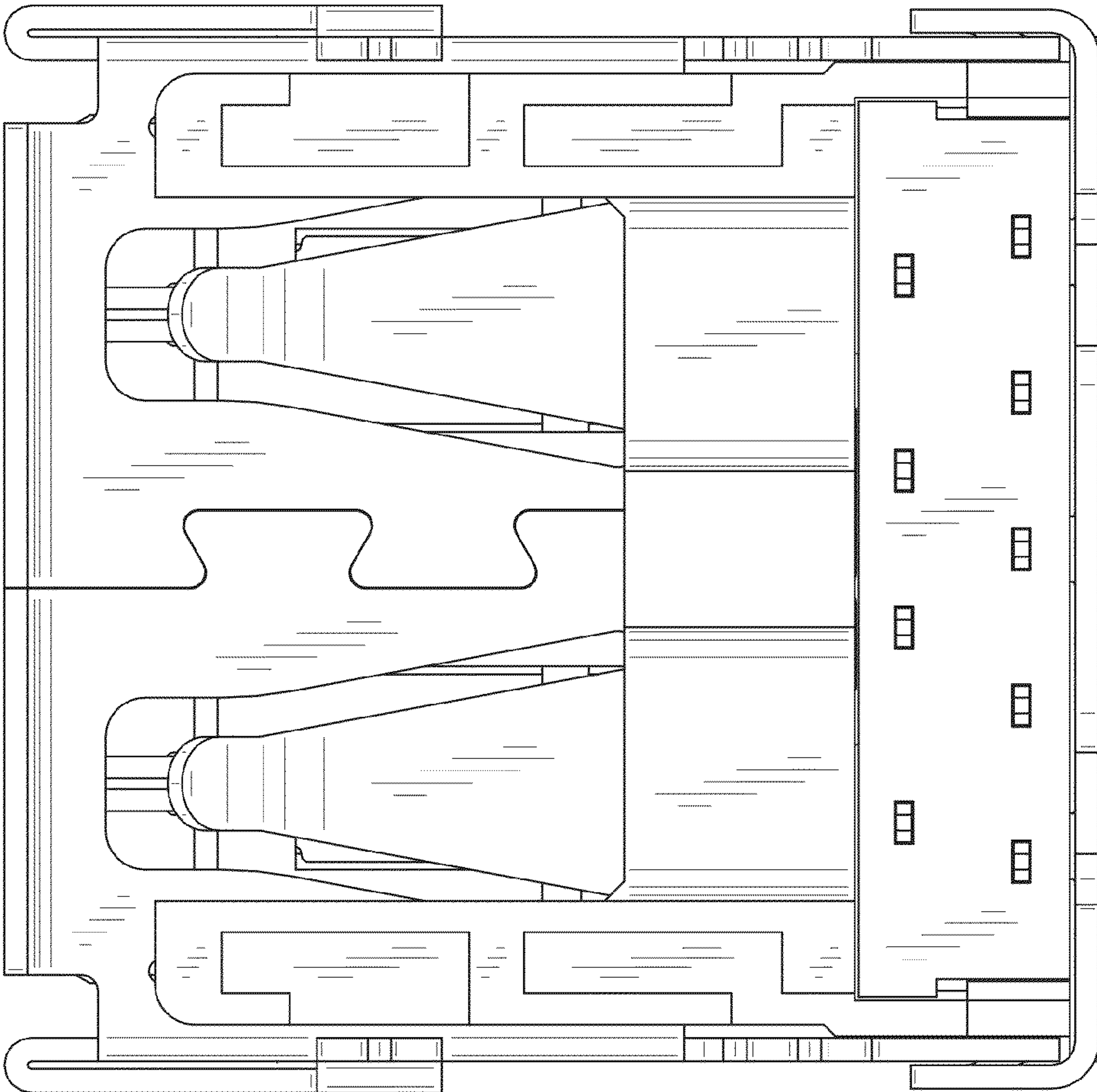

FIG.6

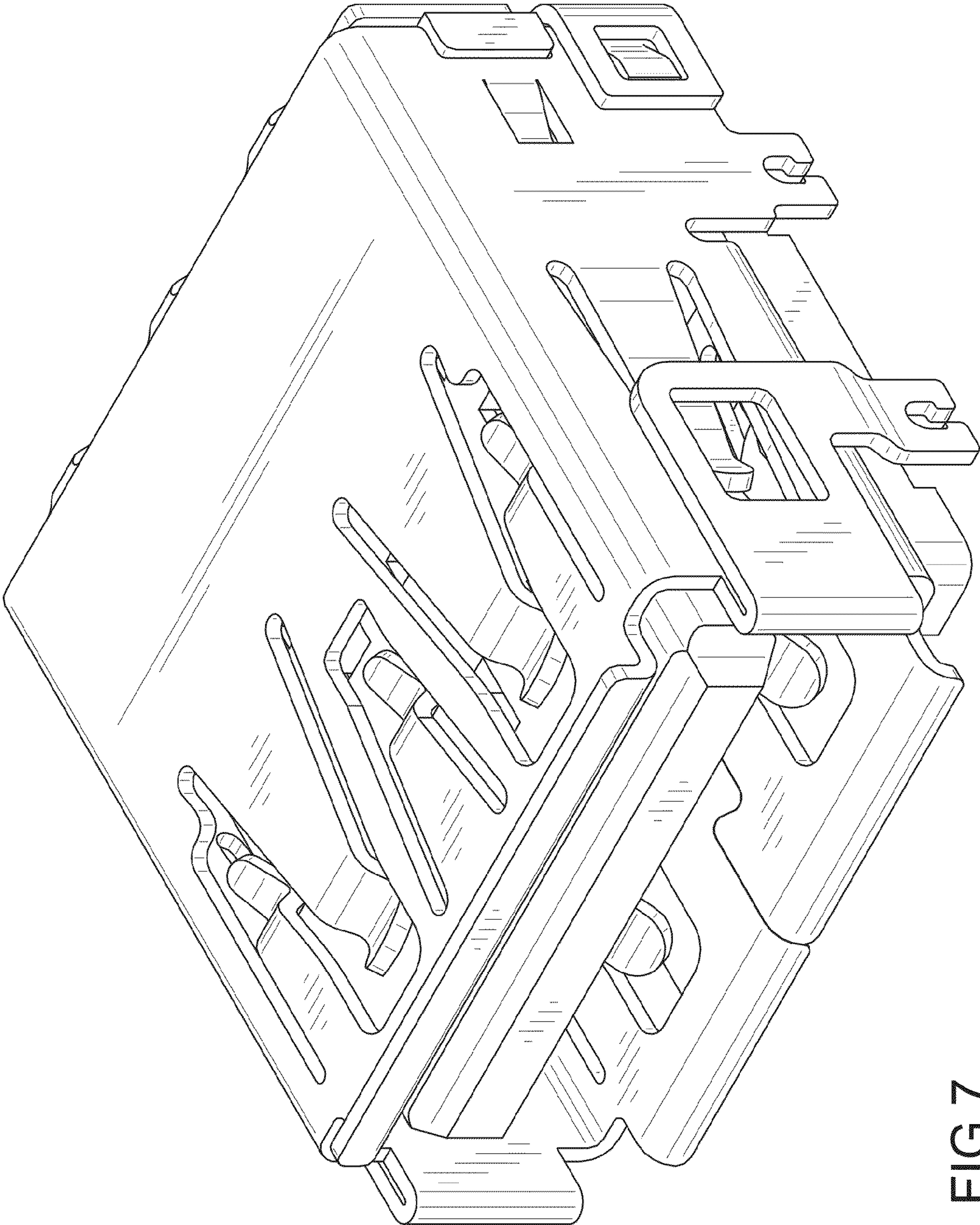

FIG. 7

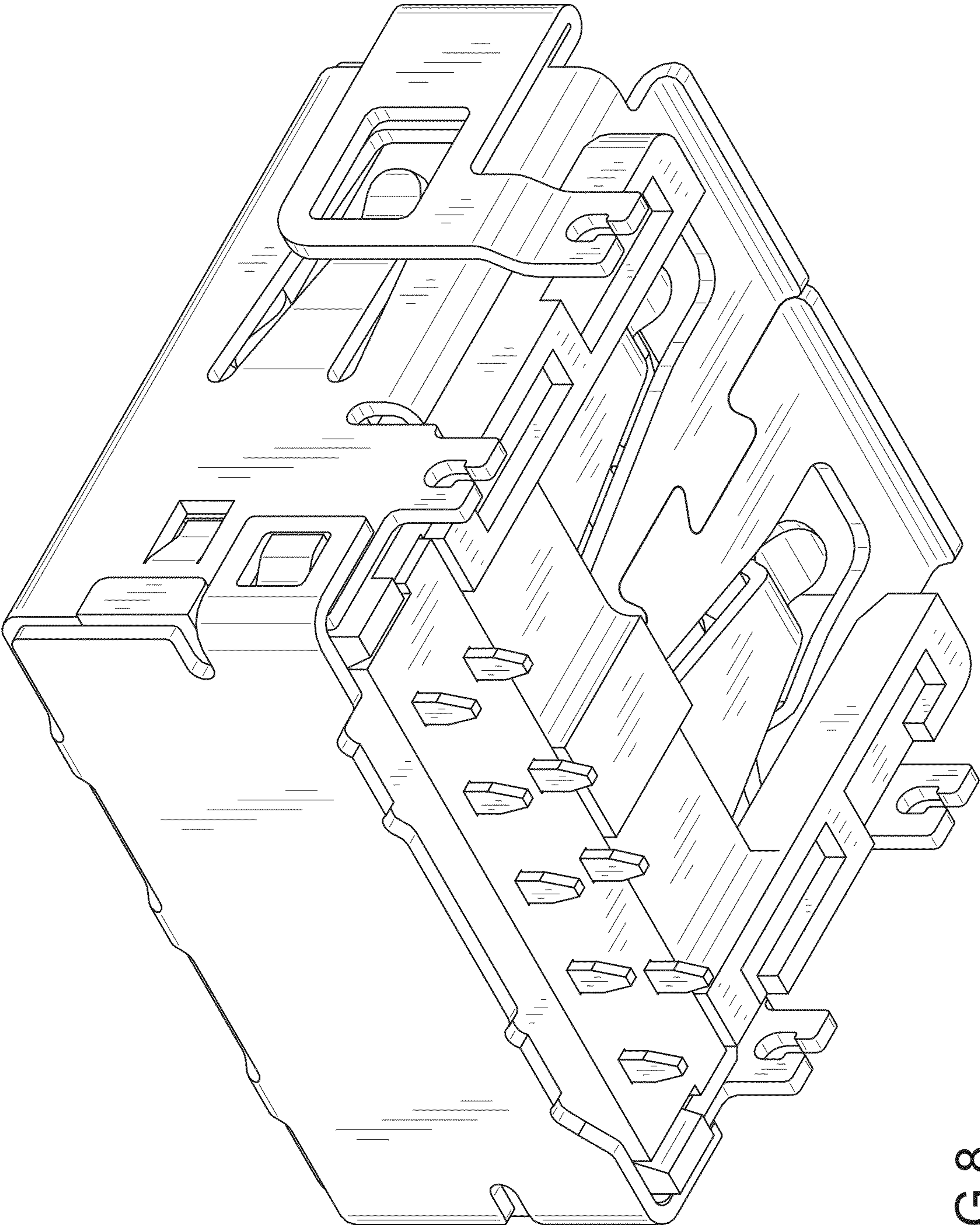

FIG.8

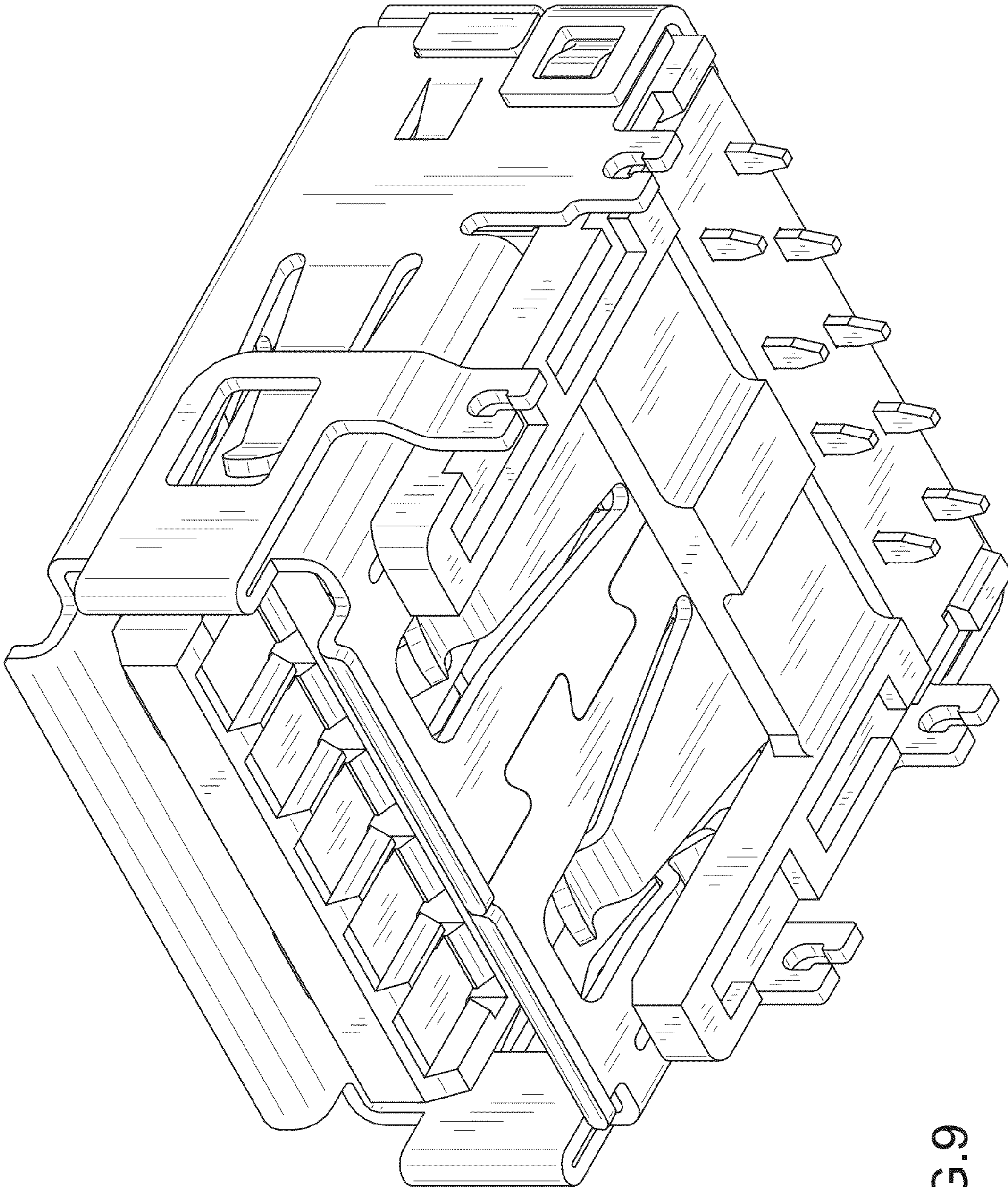

FIG.9

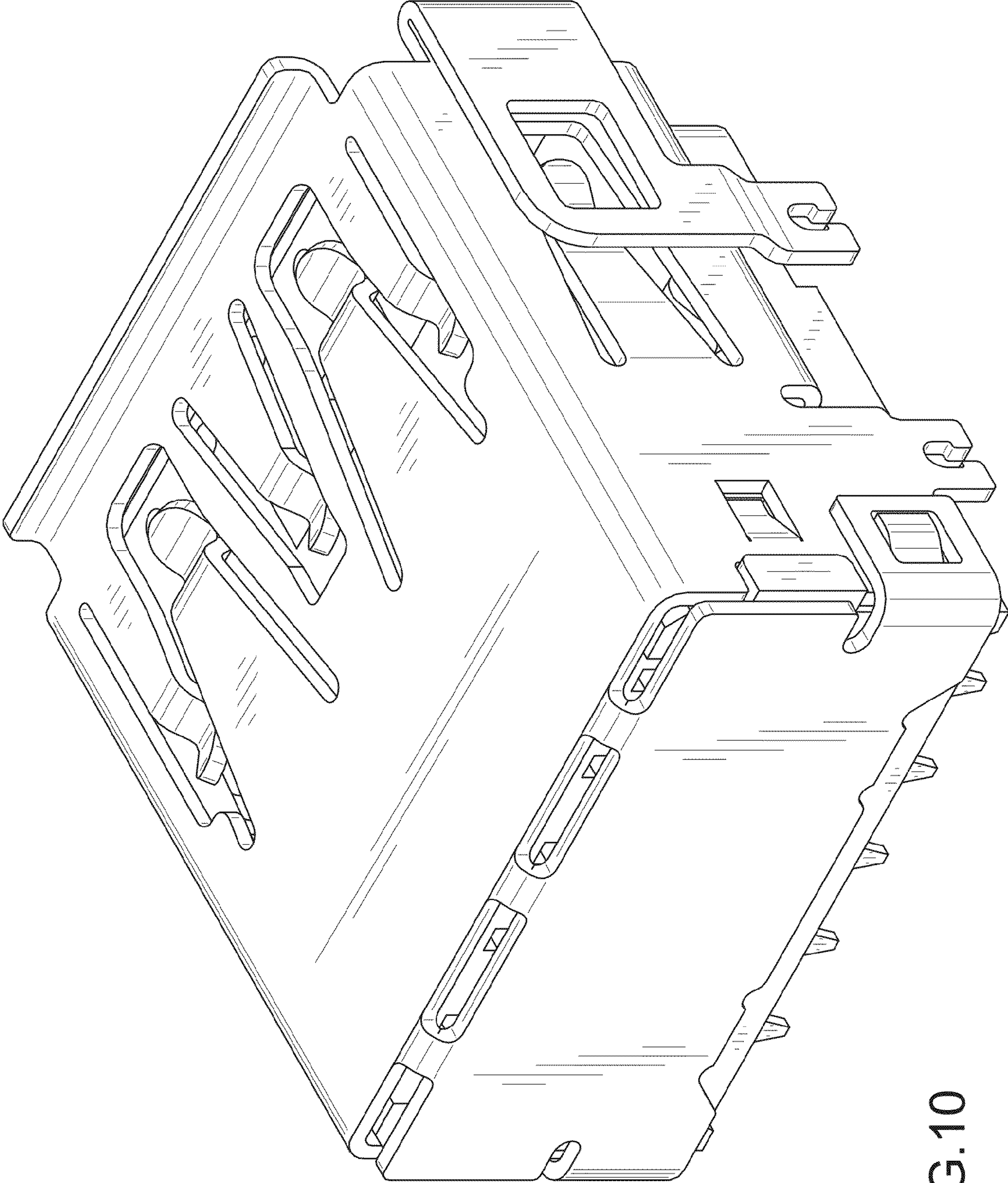

FIG.10